

---

# INSTALLATION INSTRUCTIONS

# WF - SERIES WALL FURNACE

## MODELS:

WF0501-A, -K

WF0751-A, -K

WF1001-A, -K

WF1251-A, -K

---

## WARNING

READ ALL INSTRUCTIONS CAREFULLY BEFORE BEGINNING THE INSTALLATION.

THE INSTALLATION MUST COMPLY WITH THESE INSTRUCTIONS AND THE REQUIREMENTS OF ALL GOVERNING CODES AND ORDINANCES FOR THE INSTALLATION LOCATION.

IT IS THE RESPONSIBILITY OF INSTALLER TO KNOW AND UNDERSTAND ALL OF THESE REQUIREMENTS.

FAILURE TO DO SO COULD CREATE A HAZARD RESULTING IN PROPERTY DAMAGE, BODILY INJURY, OR DEATH.

**GAS-FIRED**



CLIMATE CONTROL SOLUTIONS

Bard Manufacturing Company, Inc.  
Bryan, Ohio 43506  
*Since 1914...Moving ahead just as planned.*

Manual No.: 2100-486A  
Supersedes: 2100-486  
File: Volume III, Tab 20  
Date: 01-04-08

# CONTENTS

---

	<b>Page</b>		<b>Page</b>
Getting Other Information and Publications .....	4	16. Thermostats .....	18
WF Series Model Nomenclature .....	5	17. Gas Supply & Piping .....	21
Ventilation Options .....	5	18. Manifold Pressure Adjustment .....	22
WF Series Wall Furnace:		19. Checking Gas Input Rate .....	22 & 23
1. Important .....	6	20. Standard Orifice Sizing & High Altitude Derate .....	24
2. Application .....	6	21. Conversion of Gas Input BTUH From High to Low Rating .....	26
3. Duct Work .....	6 & 8	22. Measuring Air Temperature Rise .....	26
4. High Altitude Applications .....	8	23. Filters .....	27
5. Transportation Damage .....	8	24. Lighting & Shutdown Instructions .....	28
6. Installation .....	8	25. Service Agency Procedures .....	29
7. Wall Mounting .....	9	26. Maintaining Unit in Good Working Order ..	29 & 30
8. Mounting the Unit .....	9	27. Replacement Parts .....	30
9. Clearances .....	14	28. Sequence of Operation – Heating .....	31
10. Vent Terminal and Combustion Inlet Hood .....	15	29. Indoor Blower Operation .....	31
11. Optional Vertical Venting .....	15	30. Low NOx Burner Assembly "N" Suffix Models Only – U.S. Installations Only .....	33
12. Vent Resizing Instructions .....	16	Wiring Diagrams .....	34 – 37
13. Fresh Air Intake .....	16		
14. Wiring – Main Power .....	17		
15. Wiring – Low Voltage Wiring .....	18		

# CONTENTS

---

<b>FIGURES</b>		<b>Page</b>	<b>TABLES</b>		<b>Page</b>
Figure 1	Unit Dimensions .....	7	Table 1	Specifications – WF Models .....	6
Figure 2	Mounting Instructions .....	10	Table 2	Minimum Installation Clearances .....	14
Figure 3	Combustible Clearance .....	11	Table 3	Thermostat Wire Size .....	18
Figure 4	Wall Mounting Instructions .....	12	Table 4	Wall Thermostat .....	18
Figure 5	Wall Mounting Instructions .....	12	Table 5	Length of Standard Pipe Threads .....	21
Figure 6	Common Wall Mounting Installations ...	13	Table 6	Gas Pipe Sizes – Natural Gas .....	21
Figure 7	Location of Vent Terminal in Shipping ..	14	Table 7	Natural Gas Derate Capacities For All Models .....	24
Figure 8	Vent Terminal & Combustion Air Intake .....	15	Table 8	Natural Gas Orifice – WF050-125 .....	25
Figure 9	Fresh Air Damper .....	16	Table 9	Motor Speed Taps .....	31
Figure 10	Installation of Flexible Conduit .....	18	Table 10	Integrated Furnace & Blower Control Operation .....	32
Figure 11	Low Voltage Wiring .....	19			
Figure 12	Gas Pipe Connection .....	20			
Figure 13	Proper Piping Practice .....	21			
Figure 14	Access Internal Filter through Upper Service Door .....	27			
Figure 15	Lighting & Shutdown Instruction Label ...	28			
Figure 16	Top View of Gas Control .....	29			
Figure 17	Sequence of Operation – Electronic Blower Control .....	31			
Figure 18	Low NOx Insert .....	33			

# Getting Other Information and Publications

---

These publications can help you install the furnace. You can usually find these at your local library or purchase them directly from the publisher. Be sure to consult current edition of each standard.

National Fuel Gas Code ..... ANSI Z223.1 / NFPA 54

National Electrical Code ..... ANSI / NFPA 70

Standard for the Installation ..... ANSI / NFPA 90A  
of Air Conditioning and Ventilating Systems

Standard for Warm Air ..... ANSI / NFPA 90B  
Heating and Air Conditioning Systems

Standard for Chimneys, ..... NFPA 211  
Fireplaces, Vents, and Solid Fuel Burning Appliances

Load Calculation for ..... ACCA Manual J  
Residential Winter and Summer Air Conditioning

Duct Design for Residential ..... ACCA Manual D  
Winter and Summer Air Conditioning and Equipment  
Selection

Canadian Electrical Code ..... CSA C22.1

Canadian Installation Code.....CAN/CGA B149

## FOR MORE INFORMATION, CONTACT THESE PUBLISHERS:

**ACCA**     **Air Conditioning Contractors of America**  
1712 New Hampshire Avenue, NW  
Washington, DC 20009  
Telephone: (202) 483-9370

**ANSI**     **American National Standards Institute**  
11 West Street, 13th Floor  
New York, NY 10036  
Telephone: (212) 642-4900  
Fax: (212) 302-1286

**ASHRAE**   **American Society of Heating Refrigerating,  
and Air Conditioning Engineers, Inc.**  
1791 Tullie Circle, NE.  
Atlanta, GA 30329-2305  
Telephone: (404) 636-8400  
Fax: (404) 321-5478

**NFPA**     **National Fire Protection Association**  
Batterymarch Park  
P.O. Box 9101  
Quincy, MA 02269-9901  
Telephone: (800) 344-3555  
Fax: (617) 984-7057

**CSA**     **Canadian Standards Association**  
178 Rexdale Boulevard  
Rexdale, Ontario  
Canada. M9W 1R3  
Telephone: (416) 447-4044

COPYRIGHT SEPTEMBER 2007  
BARD MANUFACTURING COMPANY, INC.  
BRYAN, OHIO 43506 USA

Manufactured under the following U.S. patent numbers:  
5,485,878; 5,002,116; 4,924,934; 4,875,520; 4,4825,936

# WALL MOUNT GAS/ELECTRIC GENERAL

## MODEL NUMBER NOMENCLATURE

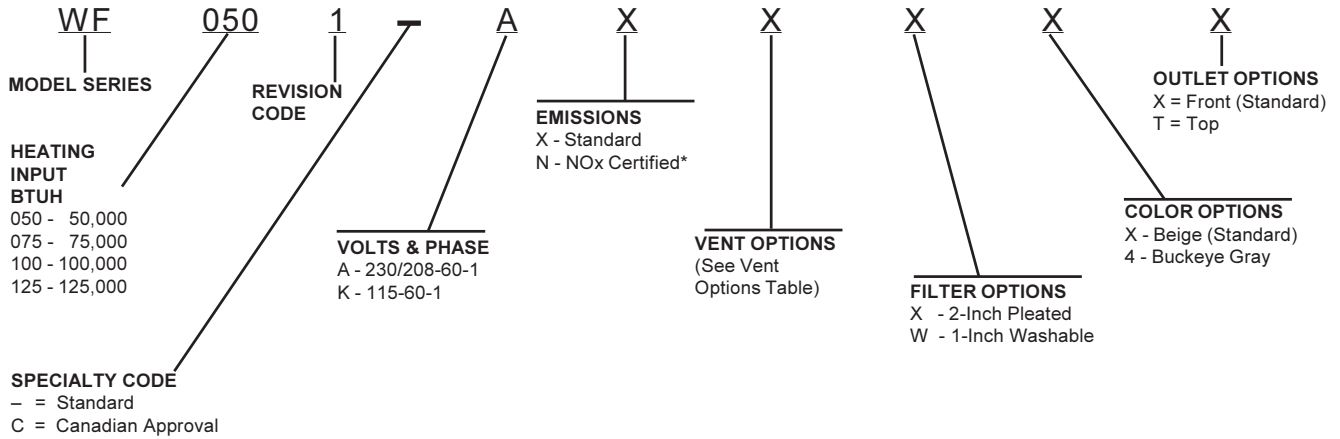

\*125,000 BTU input model is not NOx certified.

## VENTILATION OPTIONS

Models		WF
Description	Factory Installed Code No.	Field Installed Part No.
Barometric Fresh Air Damper	X	WFFAD-3
Blank-Off Plate	B	WFBOP-3
Motorized Fresh Air Damper	M	WFMFAD-3
Commercial Ventilator - Spring Return	V	WFCRVS-3
Commercial Ventilator - Power Return	P	WFCRVP-3
Energy Recovery Ventilator - 230 Volt	Field-Installed Only	WFERV-A3



# CAUTION

During the initial firing of the burners there will probably be some amount of smoke issued to the circulating air stream as the result of residual oil burning off of the heat exchanger tubes. This oil is required during the forming process of the stainless steel heat exchanger tubes to facilitate the bending. OSHA or the National Toxicology Program does not list the oil as a carcinogen. In vapor form this may be irritating to the eyes or could cause headaches. This is a one-time occurrence, and ventilation of the space may be required depending upon the space being conditioned.

## 1. IMPORTANT

The equipment covered in this manual is to be installed by trained, experienced service and installation technicians. All duct work or portions thereof not in the conditioned space should be properly insulated in order to both conserve energy and prevent condensation or moisture damage.

## 2. APPLICATION

This is a fan-assisted forced air gas furnace for outdoor installation. A fan-assisted furnace is equipped with an integral mechanical means to draw products of combustion through the combustion chamber and heat exchanger. The furnace installation must conform with local building codes and ordinances or, in their absence, with the National Fuel Gas Code ANSI Z223.1 or CAN/CGA-B149.1, latest edition, and the National Electrical Code ANSI/NFPA-7 or CSA C22.1, latest edition. It is the personal responsibility and obligation of the purchaser to contact a qualified installer to assure that installation is adequate and is in conformance with governing codes and ordinances.

## 3. DUCT WORK

The unit is designed for use with or without duct work. See Warning on Page 8. Flanges are provided for attaching the supply and return ducts. These instructions explain the recommended method to installing the gas heating unit and the electrical wiring connections and gas piping to the unit. All internal wiring is complete.

These instructions and any instructions packaged with any separate equipment required to make up the entire heating system should be carefully read before beginning the installation. Note particularly “Starting Procedure” and any tags and/or labels attached to the equipment.

All duct work, supply and return, must be properly sized for the design airflow requirement of the equipment. Air Conditioning Contractors of America (ACCA) is an excellent guide to proper sizing.

**TABLE 1  
SPECIFICATIONS  
WF050, WF075, WF100, WF125 MODELS**

Model	WF050-A	WF050-K	WF075-A	WF075-K	WF100-A	WF100-K	WF125-A	WF125-K
<i>Electrical Rating – 60HZ</i>	230/208-60-1	115-60-1	230/208-60-1	115-60-1	230/208-60-1	115-60-1	230/208-60-1	115-60-1
Minimum Circuit Ampacity	7.1	7.1	7.1	7.1	7.1	7.1	7.1	7.1
* Field Wire Size	14	14	14	14	14	14	14	14
Ground Wire Size	14	14	14	14	14	14	14	14
Fuse – Max.	15	15	15	15	15	15	15	15
<i>Motor and Evaporator</i>								
Blower Motor – HP/RPM/SPD	1/3 / 1075/3	1/3 / 1075/3	1/3 / 1075/3	1/3 / 1075/3	1/3 / 1075/3	1/3 / 1075/3	1/3 / 1075/3	1/3 / 1075/3
Blower Motor – Amps	2.2	4.6	2.2	4.6	2.2	4.6	2.2	4.6
CFM E.S.P.	1000 – .2	1000 – .2	1000 – .2	1000 – .2	1000 – .2	1000 – .2	1000 – .2	1000 – .2
Filter Sizes (Inches)	20 x 25 x 2	20 x 25 x 2	20 x 25 x 2	20 x 25 x 2	20 x 25 x 2	20 x 25 x 2	20 x 25 x 2	20 x 25 x 2

\* 75 degree C Copper wire size

**FIGURE 1  
UNIT DIMENSIONS**

A	B	C	D	E	F	G	H	I	J	K	L	M	N	O
8.00	28.937	13.75	25.00	39.87	14.81	38.18	58.37	30.00	4.50	13.25	15.37	39.17	4.31	3.18

P	Q	R	S	T	U	V	W
5.62	12.00	4.75	2.00	31.00	38.18	2.81	10.00

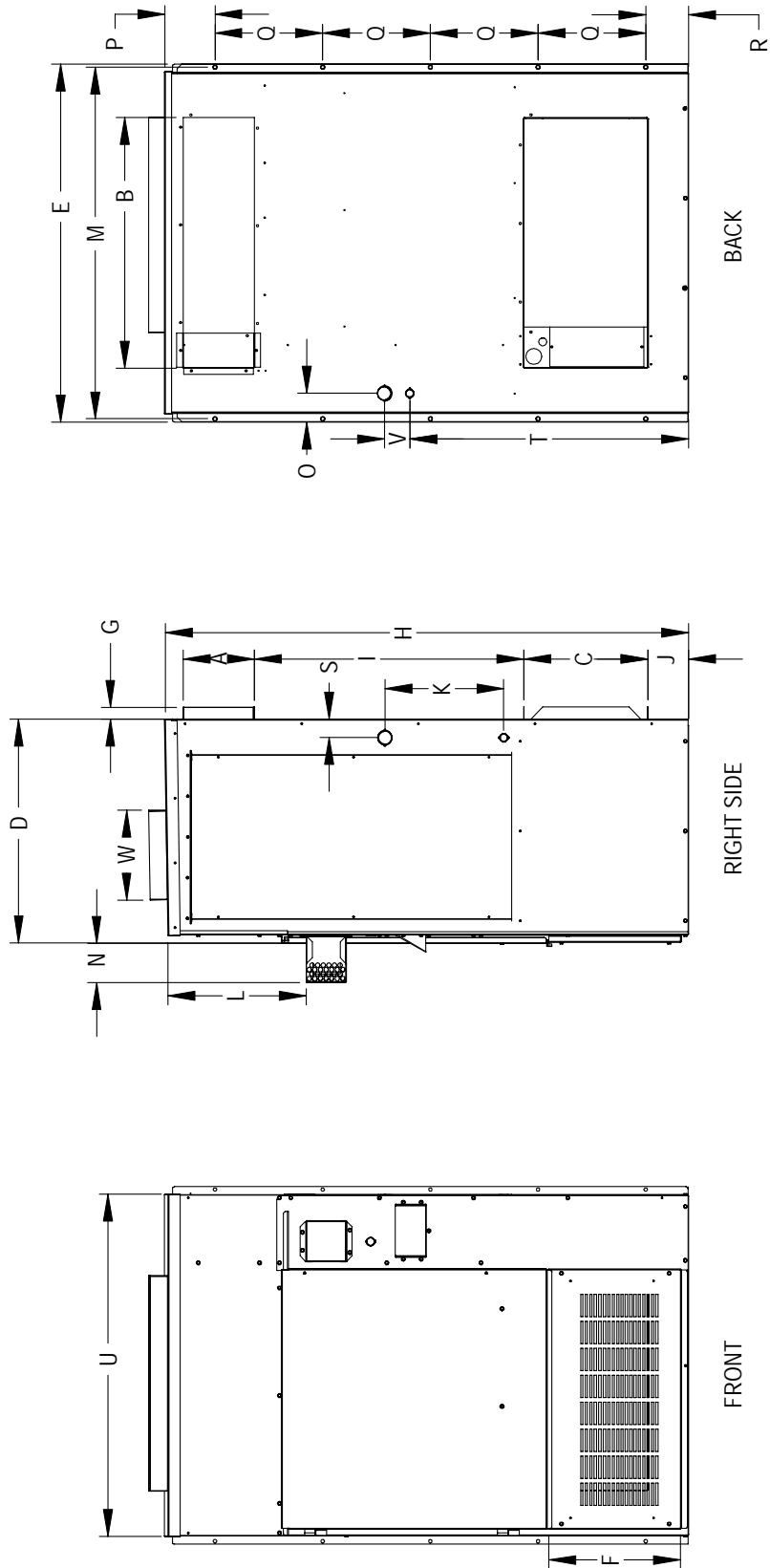

MIS-2338



## WARNING

In all cases, there must be a metal duct connection made to the supply air flange, and a one inch clearance to combustibles must be maintained to this duct connection.

For free blow applications, a metal sleeve (field-supplied) must be used in the wall opening itself, again maintaining a one inch clearance to combustibles.

Failure to use the sheet metal can cause fire resulting in property damage, injury, or death.

See Figure 3 and clearance information in Section 9 and Table 2 for additional information.

Design the duct work according to methods given by the Air Conditioning Contractors of America (ACCA). When duct runs through unheated spaces, it should be insulated with a minimum of one-inch of insulation. Use insulation with a vapor barrier on the outside of the insulation. Flexible joints should be used to connect the duct work to the equipment in order to keep the noise transmission to a minimum.

A one-inch clearance to combustible material for the first three feet of duct attached to the outlet air frame is required. See Wall Mounting Instructions and Figures 2 and 3 for further details.

Ducts through the walls must be insulated and all joints taped or sealed to prevent air or moisture entering the wall cavity.

Some installations may not require any return air duct. A metallic return air grille is required with installations not requiring a return air duct. The spacing between louvers on the grille shall not be larger than 5/8 inch.

Any grille that meets with the 5/8 inch louver criteria may be used. It is recommended that Bard Return Air Grille or Return Filter Grille be installed when no return duct is used. Contact distributor or factory for ordering information. If using a return air filter grille, filters must be of sufficient size to allow a maximum velocity of 400 fpm.

*NOTE: If no return air duct is used, applicable installation codes may limit this cabinet to installation only in a single story structure.*

## 4. HIGH ALTITUDE APPLICATIONS

Ratings of gas utilization equipment are based on sea level operation and need not be changed for operation at elevations up to 6,000 feet. For operation at elevations above 6,000 feet and in the absence of specific recommendations from the local authority having jurisdiction, equipment ratings shall be reduced as specified in Section 20.

## 5. TRANSPORTATION DAMAGE

All units are packed securely in shipping container. All units should be carefully inspected upon arrival for damage. In the event of damage, the consignee should:

1. Note on delivery receipt of any damage to container.
2. Notify carrier promptly, and request an inspection.
3. In case of concealed damage, the carrier must be notified as soon as possible within 15 days after delivery.
4. Claims for any damage, apparent or concealed, should be filed with the carrier, using the following supporting documents:
  - A. Original Bill of Lading, certified copy, or indemnity bond.
  - B. Original paid freight bill of indemnity in lieu thereof.
  - C. Original invoice or certified copy thereof showing trade and other discounts or deductions.
  - D. Copy of the inspection report issued by carrier's representative at the time damage is reported to carrier.

## 6. INSTALLATION

Size of unit for proposed installation should be based on heat loss/heat gain calculations made according to methods of Air Conditioning Contractors of America (ACCA). The air duct should be installed in accordance with the Standards of the National Fire Protection Association for the Installation of Air Conditioning and Ventilating Systems of Other Than Residence Type, NFPA No. 90A, and Residence Type Warm Air Heating and Air Conditioning Systems, NFPA No. 90B. Where local regulations are at a variance with instructions, installer should adhere to local codes.



## 7. WALL MOUNTING INFORMATION

1. Two holes for the supply and return air openings must be cut through the wall as detailed in Figure 4.
2. On wood-frame walls, the wall construction must be strong and rigid enough to carry the weight of the unit without transmitting any unit vibration.
3. Concrete block walls must be thoroughly inspected to insure that they are capable of carrying the weight of the installed unit.

## 8. MOUNTING THE UNIT

1. These units are secured by wall mounting brackets which secure the unit to the outside wall surface at both sides.
2. For all models the supply air duct flange and the first 3 feet of supply air duct require a minimum of 1-inch clearance to combustible material. The WF models are suitable for 0 inch clearance on the installation mounting wall, but require 1-inch clearance to the top if combustible material overhang projects above the unit. See Figure 3. If a combustible wall, use a minimum of Figure 1 "A" dimension plus 2 inches and "B" dimension plus 2 inches. See Figures 4 and 5 for details.

# **WARNING**

Failure to provide the one inch clearance between the supply duct and a combustible surface for the first three feet of duct can result in fire causing damage, injury or death.

3. Locate and mark lag bolt locations.
4. Hook top rain flashing under back bend of top. Top rain flashing is shipped secured to the right side of the back.
5. Position unit in opening and secure with 5/16 lag bolts; use 7/8 inch diameter flat washers on the lag bolts. Use lag bolts long enough to support the unit's weight when mounted to the structure. This length may be dependant on the type of construction.
6. Secure rain flashing to wall and caulk across entire length of top. See Figure 3.
7. On side-by-side installations, maintain a minimum of 20 inches clearance on right side to allow access to control panel and burner compartment. Additional clearance may be required to meet local or national codes.

**FIGURE 2  
MOUNTING INSTRUCTIONS**

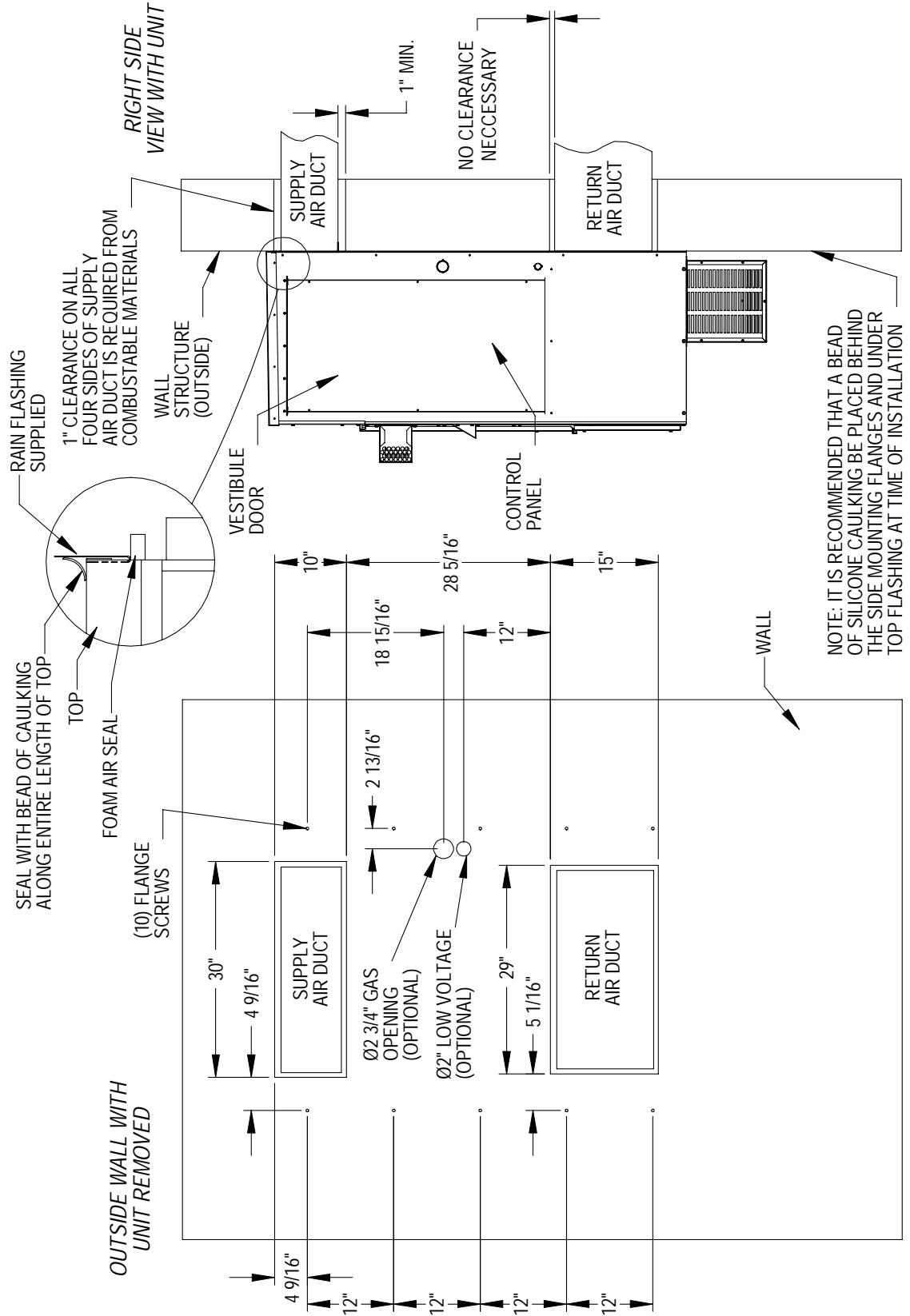

MIS-2371

**FIGURE 3  
COMBUSTIBLE CLEARANCE  
FOR WF MODELS**

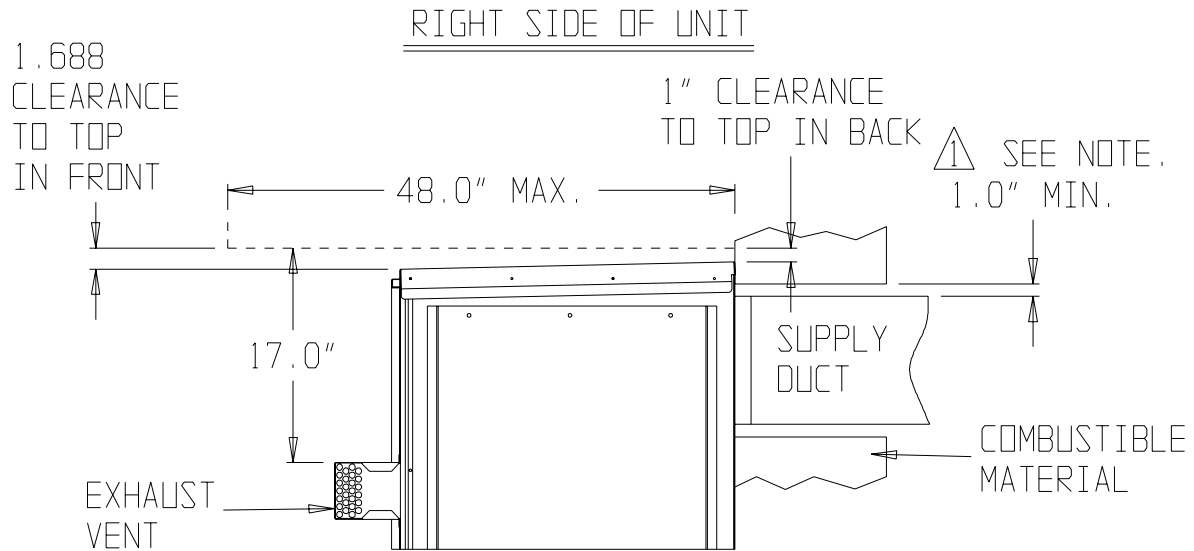

⚠ SIDE SECTION VIEW OF SUPPLY AIR DUCT FOR WALL MOUNTED UNIT SHOWING 1.0" CLEARANCE TO ALL COMBUSTIBLE SURFACES.

MIS-2383



## WARNING

A **minimum** of one (1) inch clearance must be maintained between the supply air duct and combustible materials. This is required for the first three (3) feet of ducting.

It is important to insure that the one (1) inch minimum spacing is maintained at all points.

Failure to do this could result in overheating the combustible material and may result in a fire causing damage, injury or death.

**FIGURE 4  
WALL MOUNTING INSTRUCTIONS**

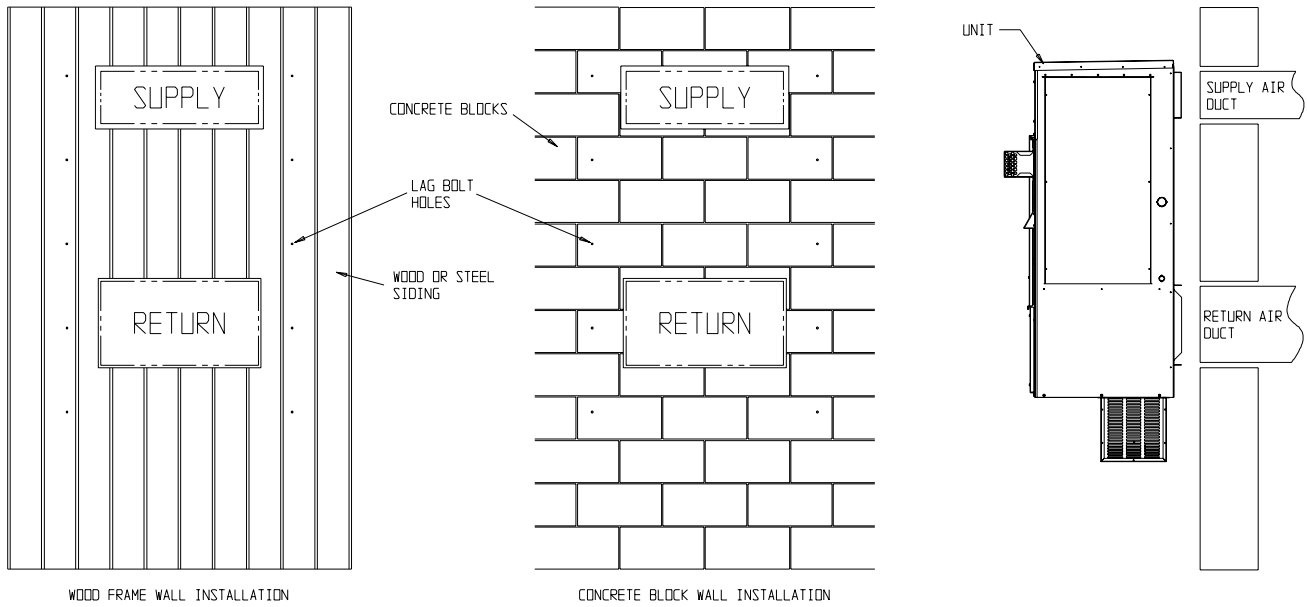

MIS-2372

**FIGURE 5  
WALL MOUNTING INSTRUCTIONS**

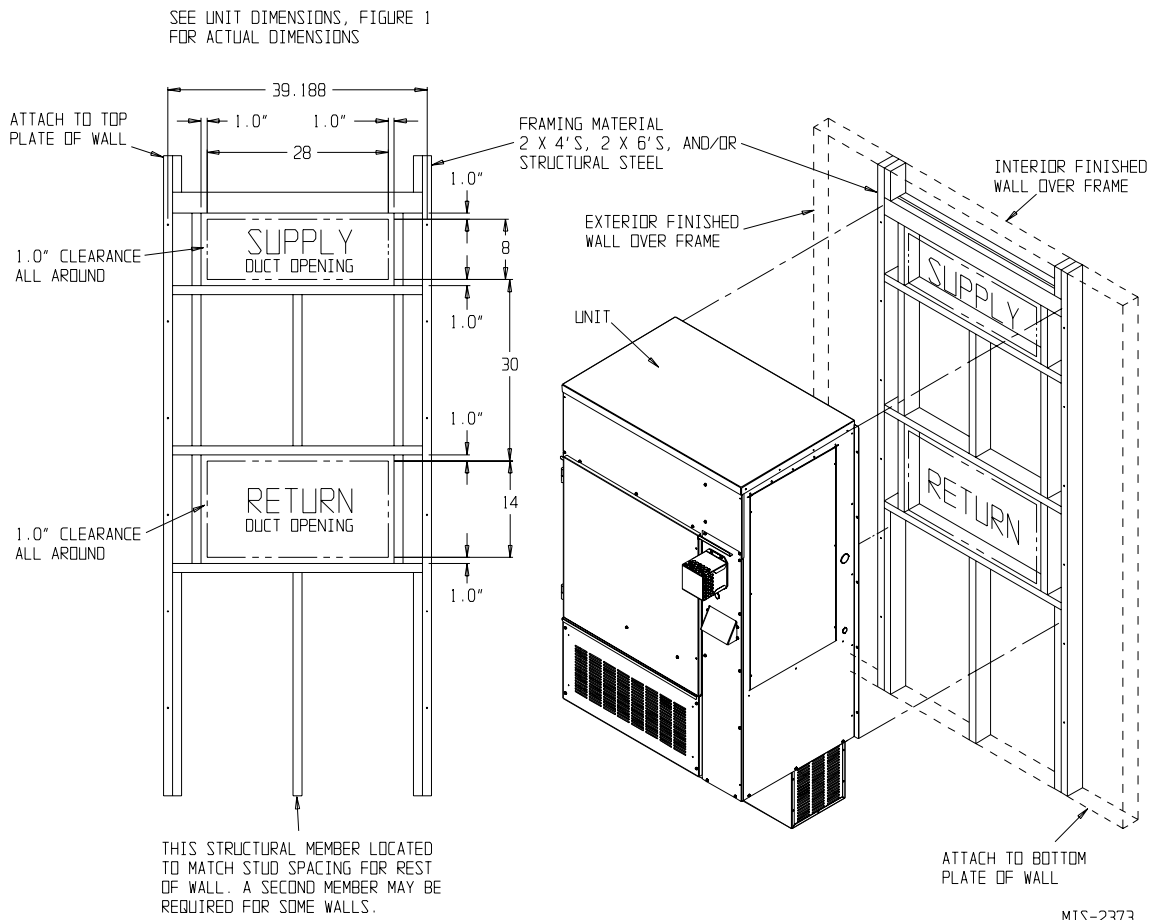

MIS-2373

**FIGURE 6  
COMMON WALL MOUNTING INSTALLATIONS**

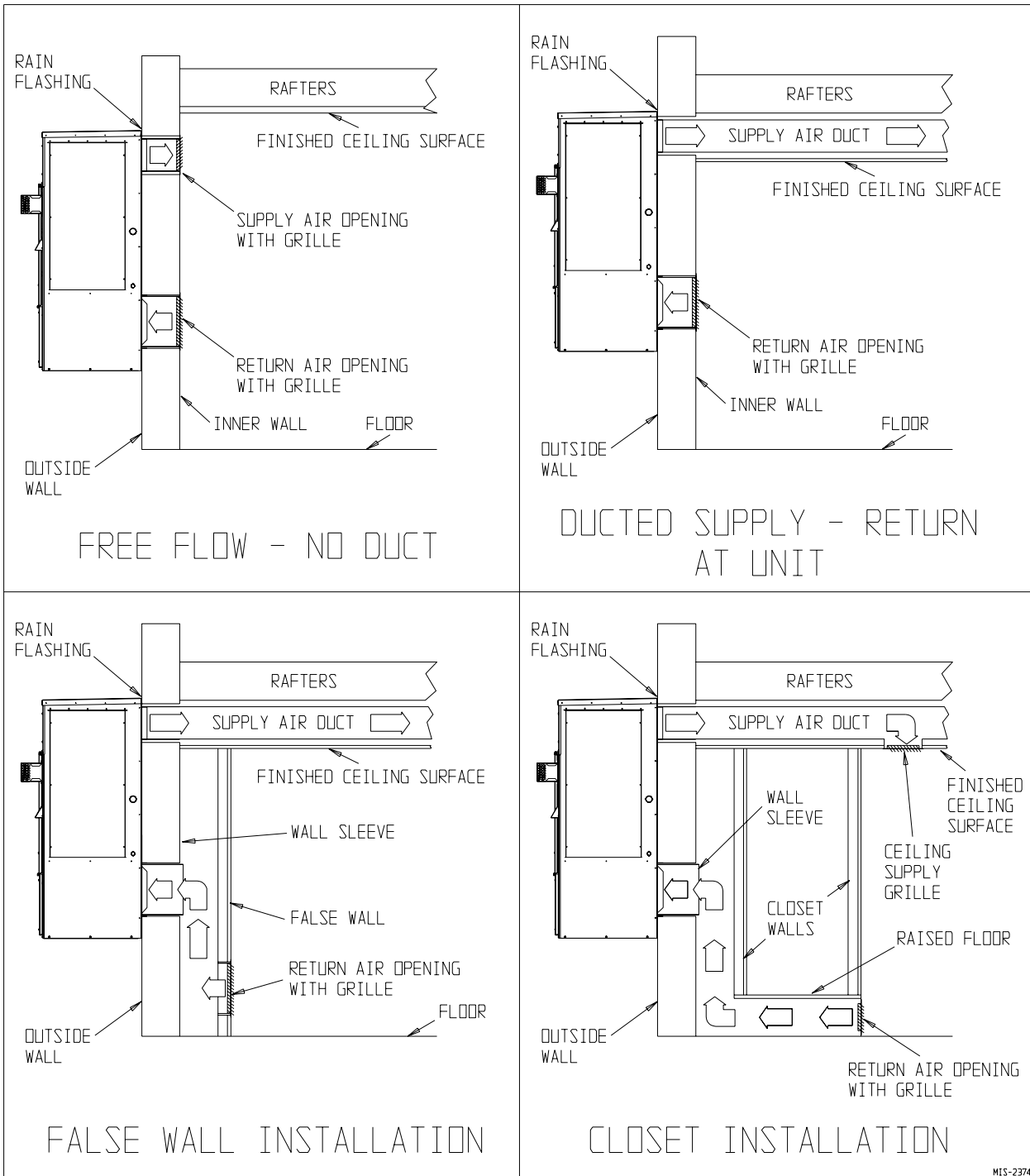

## 9. CLEARANCES

Minimum clearances, as specified in Table 2, must be maintained from adjacent structures to provide adequate fire protection, adequate combustion air, and room for service personnel.

While minimum clearances are acceptable for safety reasons, they may not allow adequate air circulation around the unit for proper operation. Whenever possible, it is desirable to allow additional clearance.

**TABLE 2**  
**MINIMUM INSTALLATION CLEARANCES**

Outlet Duct (from combustible materials)	1 inch first 3 feet
Vent Terminal (from combustible materials)	17 inches
Top	1 inch
Burner Service	20 inches
Combustible Base (Wood or Class A, B or C roof covering material)	0 inches

### **WARNING**

Clearances from combustible materials must be maintained as specified. Failure to maintain clearances could cause fire resulting in property damage, injury, or death.

**FIGURE 7**  
**LOCATION OF VENT TERMINAL IN SHIPPING**

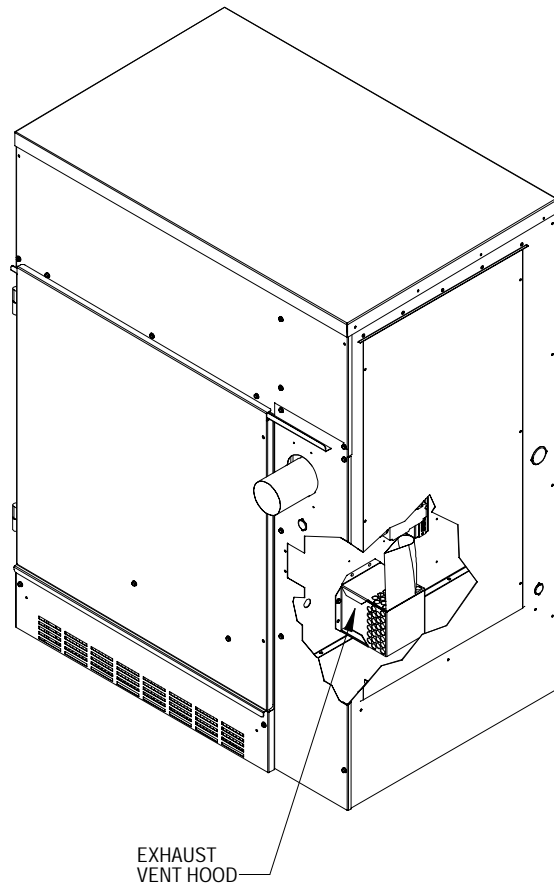

MIS-2375

## 10. VENT TERMINAL AND COMBUSTION AIR INLET HOOD

The vent terminal is shipped in the burner compartment. See Figure 7. Remove the two shipping screws and separate the two-piece assembly. Install the vent terminal by using the four screws provided. **Do not cut or trim gasket. Make sure gasket is in place.** See Figure 8. The combustion air intake hood is factory installed.

## 11. OPTIONAL VERTICAL VENTING

With the optional vertical venting kit (VVK-5A) this unit may be vented vertically through a roof or overhang. The kit includes a stainless steel transition drain tee, silicone sealant, and drain tubing.

If unit is installed with vertical vent kit, annually inspect the vent system and drain. Replace any portion of the vent system that shows signs of deterioration. Make sure drain is open and free of obstruction.



# CAUTION

Vent terminal must be installed as shown in Figure 8 for proper operation of the heating system.

**NOTE: The inner vent hood gasket is designed to stretch over and seal around the combustion air blower outlet. This is a very critical seal to prevent water and flue products from entering the unit. Care must be taken to insure this gasket is in place and sealing properly.**

FIGURE 8  
VENT TERMINAL AND COMBUSTION AIR INTAKE

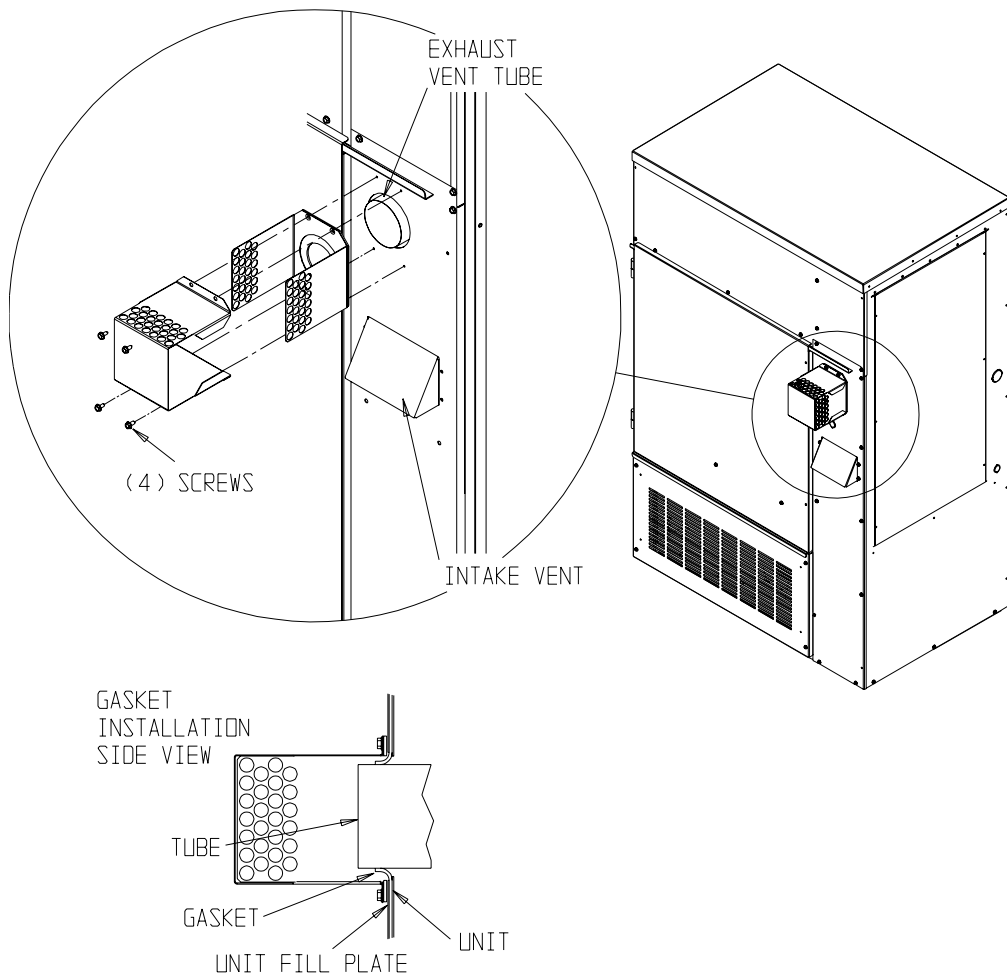

## 12. VENT RESIZING INSTRUCTIONS

When an existing furnace is removed from a venting system servicing other appliances, the venting system is likely to be too large to properly vent the remaining attached appliances.

The following steps shall be followed with each of the appliances remaining connected to the common venting system, placed in operation one at a time while the other appliances remaining connected to the common venting system are not in operation.

1. Seal any unused openings in the venting system.
2. Inspect the venting system for proper size and horizontal pitch, as required in the National Fuel Gas code, ANSI Z223.1 or the CAN/CGA B149 Installation Codes and these instructions. Determine that there is no blockage or restriction, leakage, corrosion and other deficiencies which could cause an unsafe condition.
3. In so far as is practical, close all building doors and windows and all doors between the space in which the appliance(s) connected to the venting system are located and other spaces of the building. Turn on clothes dryers and any appliances not connected to the venting system. Turn on any exhaust fans, such as range hoods and bathroom exhausts, so they will operate at maximum speed. Do not operate a summer exhaust fan. Close fireplace dampers.
4. Follow the lighting instructions. Place the appliance being inspected in operation. Adjust thermostat so appliance shall operate continuously.
5. Test for draft hood equipped appliance spillage at the draft hood relief opening after 5 minutes of main burner operation. Use the flame of a match or candle.
6. After it has been determined that each appliance connected to the venting system properly vents when tested as outlined above, return doors, windows, exhaust fans, fireplace dampers and any other gas-burning appliances to their previous conditions of use.
7. If improper venting is observed during any of the above tests, the venting system must be corrected.

## 13. FRESH AIR INTAKE

All units are built with fresh air inlet slots punched in the service panel.

If the unit is equipped with a fresh air damper assembly, the assembly is shipped already attached to the unit. The damper blade is locked in the closed position. To allow the damper to operate, the maximum and minimum blade position stops must be installed. See Figure 9.

All capacity, efficiency and cost of operation information as required for Department of Energy "Energyguide" Fact Sheets is based upon the fresh air blank-off plate in place and is recommended for maximum energy efficiency.

The blank-off plate is available upon request from the factory and is installed in place of the fresh air damper shipped with each unit.

One of several other ventilation options may be installed. Refer to model number and/or supplemental installation instructions.

**FIGURE 9  
FRESH AIR DAMPER**

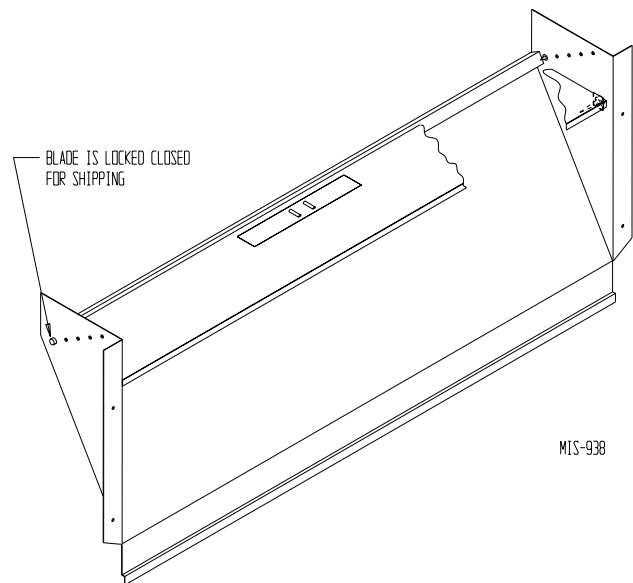



## 14. WIRING – MAIN POWER



### WARNING

For your personal safety, turn off electric power at service entrance panel before making any electrical connections. Failure to do so could result in electric shock or fire.

Refer to unit rating plate for wire sizing information and maximum fuse or circuit breaker size. Each outdoor unit is marked with a “Minimum Circuit Ampacity”. This means that the field wiring used must be sized to carry that amount of current. All models are suitable only for connection with copper wire. Each unit and/or wiring diagram will be marked - “*Use Copper Conductors Only*”. These instructions **must be** adhered to. Refer to the National Electrical Code (NEC) for complete current carrying capacity data on the various insulation grades of wiring material. All wiring must conform to NEC and all local codes.

The electrical data lists fuse and wire sizes (75° C copper) for all models.

The unit rating plate lists a “Maximum Fuse” or circuit breaker that is to be used with the equipment. The correct size must be used for proper circuit protection.

See “Start Up” section for important information on three phase scroll compressor start ups.



### WARNING

Failure to provide an electrical power supply shut off means could result in electric shock or fire.

## ELECTRICAL GROUNDING

When installed, the furnace must be electrically grounded in accordance with local codes or in the absence of local codes, with the National Electrical Code, ANSI/NFPA 70, or Canadian Electrical Code, CSA22.1, latest edition. Use a copper wire from green ground wire on the furnace to a grounded connection in the service panel or a properly driven and electrically grounded ground rod. See Table 1 for proper ground wire size.



### WARNING

Failure to provide a proper electrical ground could result in electric shock or fire.

## FIELD INSTALLED EQUIPMENT

Wiring to be done in the field between the furnace and devices not attached to the furnace, or between separate devices which are field installed and located, shall conform with the temperature limitation for Type T wire {63 degrees F rise (36 degrees C)} when installed in accordance with the manufacturer’s instructions.

## INSTALLATION OF FLEXIBLE CONDUIT THROUGH RETURN AIR OPENING

*NOTE: To allow proper clearance between the control panel and any vent options, 90° conduit fittings must be used on the back of the control panel.*

## INSTALLING CONDUIT (See Figure 10.)

1. Remove conduit access panel if required to gain access to area behind control panel.
2. Remove low voltage and high voltage knockouts located in rear of control panel.
3. Run low voltage conduit through 7/8 bushing located in conduit entrance plate and secure to low voltage opening in rear of control panel.
4. Run high voltage conduit through 1-3/4 bushing located in conduit entrance plate and secure to high voltage opening in rear of control panel.
5. Replace conduit access panel if required to complete installation.
6. Seal around conduit in conduit entrance plate.

**FIGURE 10  
INSTALLATION OF FLEXIBLE CONDUIT**

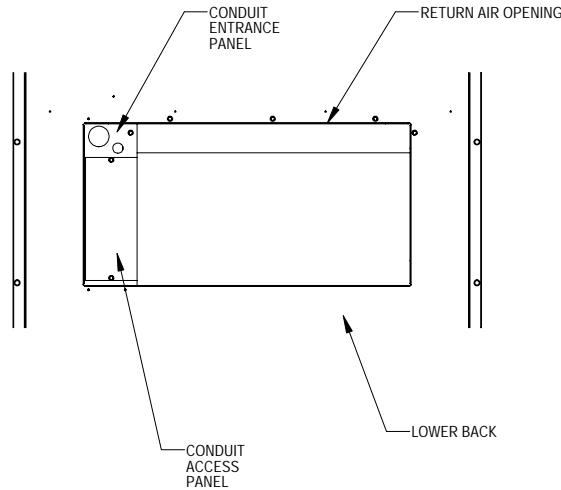

MIS-2378

**15. WIRING – LOW VOLTAGE WIRING**

**Low Voltage Connection**

These units use a 24-volt AC low voltage circuit. The “R” terminal is the *hot* terminal and the “C” terminal is *grounded*.

“G” terminal is the *fan input*.

“R” terminal is 24 VAC *hot*.

“C” terminal is 24 VAC *grounded*.

“F” terminal is the *ventilation input*. This terminal energizes any factory or field installed vent option.

“W” terminal is the *gas valve input*.

**230/208 VOLT UNITS**

All models are equipped with dual primary voltage transformers. Equipment leaves the factory wired for either 230V or 115V. For 208V operation, reconnect from 230V to 208V tap.

*NOTE: The voltage should be measured at the field power connection point in the unit and while the unit is operating at full load (maximum amperage operating condition).*

**Direct Digital Controls (DDC)**

For total and proper control using DDC, a total of 5 controlled outputs are required (4 if no ventilation is installed).

LOW VOLTAGE CONNECTIONS FOR DDC CONTROL	
Fan Only	Energize G
Heating Mode	Energize W
Ventilation	Energize G, F

**16. THERMOSTATS**

**TABLE 3  
THERMOSTAT WIRE SIZE**

Transformer VA	FLA	Wire Gauge	Maximum Distance In Feet
40	2.3	20 gauge	45
		18 gauge	60
		16 gauge	100
		14 gauge	160
		12 gauge	250

**TABLE 4  
WALL THERMOSTAT**

Thermostat	Predominate Features
8403-057 (TH3110D1040)	1 stage heat; 1 stage cool System: heat-off-cool Fan: on-auto Electronic Non-Programmable
8403-060 (1120-445)	3 stage Cool; 3 stage Heat Programmable/Non-Programmable Electronic HP or Conventional Auto or Manual changeover

**FIGURE 11  
LOW VOLTAGE WIRING**

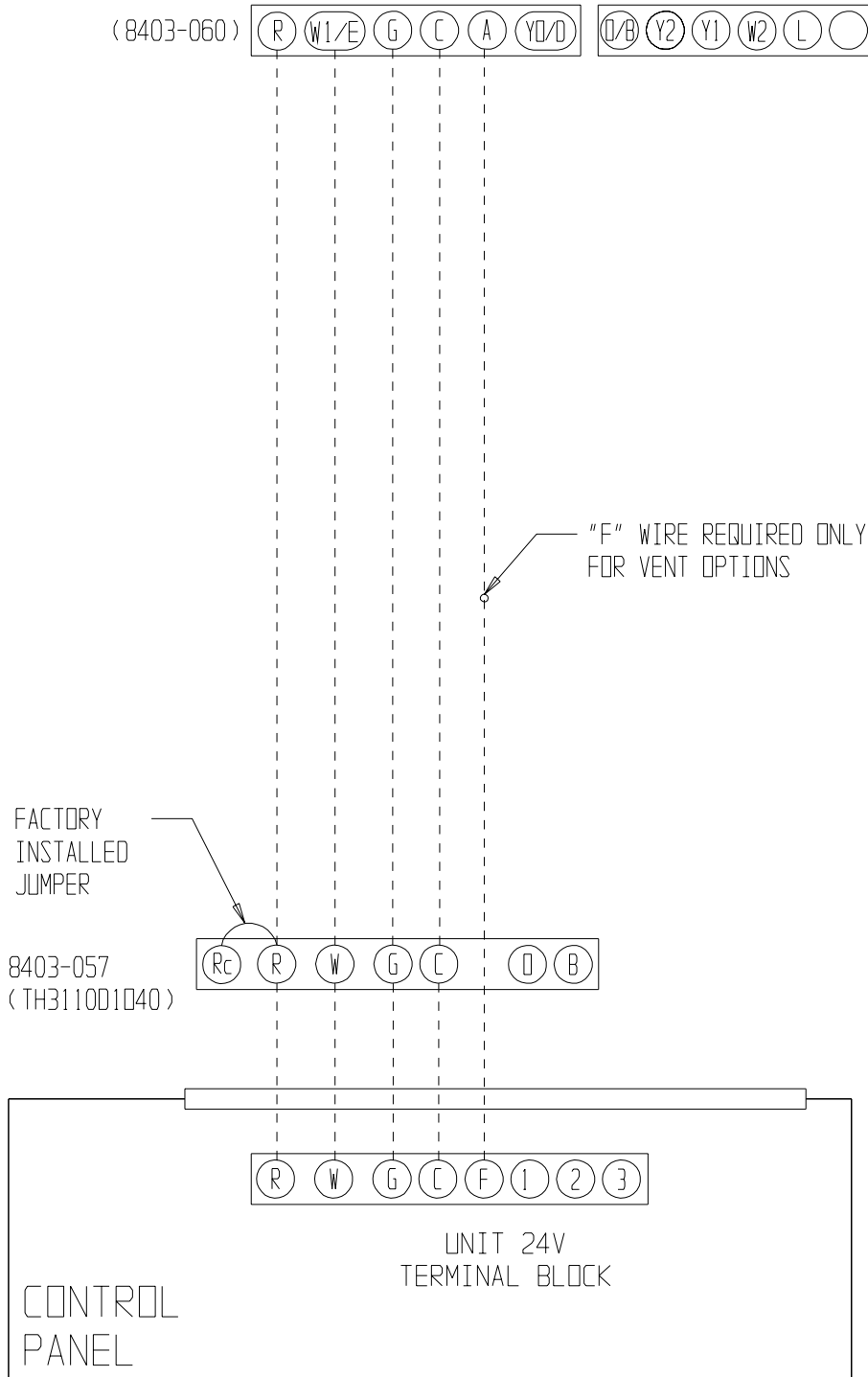

MIS-2385 A

**FIGURE 12  
GAS PIPE CONNECTION**

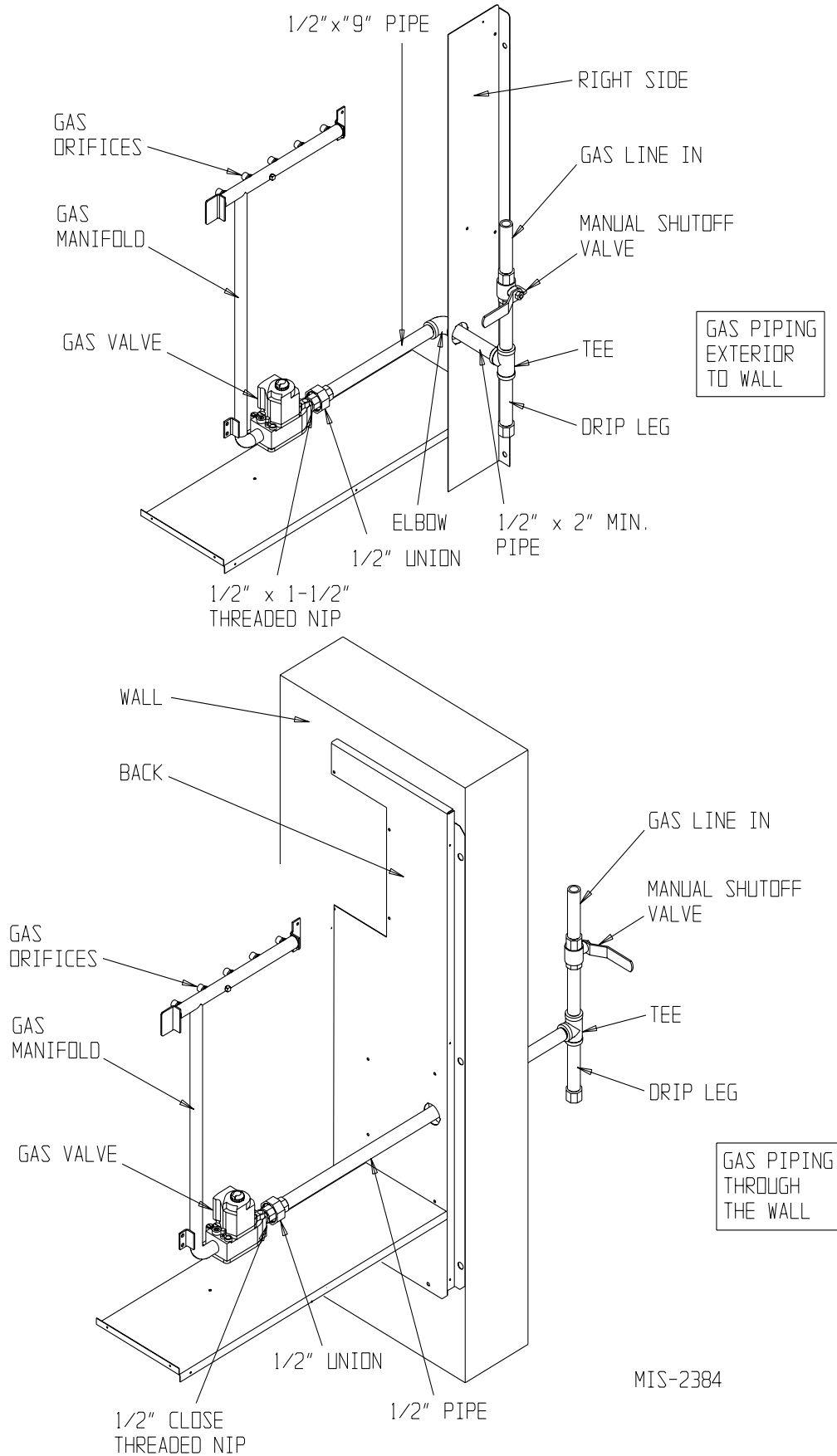

MIS-2384

## 17. GAS SUPPLY AND PIPING

### GENERAL RECOMMENDATIONS

1. Be sure the gas line complies with the local codes and ordinances, or in their absence with the National Fuel Gas Code, ANSI Z223.1, or Natural Gas Installation Code, CAN/CGA B149.1, or Propane Installation Code B149.2, latest edition.
2. A sediment trap or drip leg must be installed in the supply line to the furnace.
3. A ground joint union shall be installed in the gas line adjacent to and upstream from the gas valve and downstream from the manual shut off valve.
4. An 1/8" NPT plugged tapping accessible for test gauge connection shall be installed immediately upstream of the gas supply connection to the furnace for the purpose of determining the supply gas pressure. This can be omitted if local codes permit use of plugged tapping in gas valve inlet.
5. Install listed manual shut off valve in the supply gas line external to and immediately upstream of the furnace. See Figure 12.
6. Use steel or wrought iron pipe and fittings.
7. *DO NOT* thread pipe too far. Valve distortion or malfunction may result from excess pipe within the control. Use pipe joint compound resistant to the action of liquefied petroleum gases on male threads only. *DO NOT* use Teflon tape. See Table 5 and Figure 13.

**TABLE 5  
LENGTH OF STANDARD  
PIPE THREADS (INCHES)**

Pipe Size	Effective Length of Thread	Overall Length of Thread
3/8	1/2	9/16
3/4	1/2 - - 9/16	13/16
1	9/16	1

**FIGURE 13  
PROPER PIPING PRACTICE**

PROPER PIPING PRACTICE



USE MODERATE AMOUNT OF THREAD SEALANT, LEAVE 2 END THREADS BARE

MIS-897

8. Refer to Table 6 for Gas Pipe Sizes for natural gas. If more than one appliance is supplied from a single line size, capacity must equal or exceed the combined input to all appliances, and the branch lines feeding the individual appliances properly sized for each input.

**THIS PRODUCT MUST BE GAS PIPED BY  
A LICENSED PLUMBER OR GAS FITTER  
IN THE COMMONWEALTH OF  
MASSACHUSETTS.**

**TABLE 6  
GAS PIPE SIZES - NATURAL GAS**

Length of Pipe - Feet	Pipe Capacity - BTU per Hour Input Pipe Size			
	1/2"	3/4"	1"	1-1/4"
10	132,000	278,000	520,000	1,050,000
20	92,000	190,000	350,000	730,000
30	73,000	152,000	285,000	590,000
40	63,000	130,000	245,000	500,000
50	56,000	115,000	215,000	440,000
60	50,000	105,000	195,000	400,000
70	46,000	96,000	180,000	370,000
80	43,000	90,000	170,000	350,000
100	38,000	79,000	150,000	305,000

### CHECKING THE GAS PIPING

Before turning gas under pressure into piping, all openings from which gas can escape should be closed. Immediately after turning on gas, the system should be checked for leaks. This can be done by watching the 1/2 cubic foot test dial and allowing 4 minutes to show any movement, and by soaping each pipe connection and watching for bubbles. If a leak is found, make the necessary repairs immediately and repeat the above test. The furnace must be isolated from the gas supply piping system by closing the manual shut off valve on the combination gas control valve during pressure testing of the gas supply piping system at pressures up to 1/2 PSIG. The furnace and its individual shut off valve must be disconnected from supply piping and supply piping capped during any pressure testing of supply piping system at test pressures in excess of 1/2 PSIG.

Defective pipes or fittings should be replaced and not repaired. Never use a flame or fire in any form to locate gas leaks; use a soap solution.

After the piping and meter have been checked completely, purge the system of air. *DO NOT* bleed air inside the furnace. **Be sure to check and relight all the gas pilots on other appliances that may have been extinguished because of interrupted gas supply.**

## **PROPANE (LP) GAS CONVERSION**

This unit may be converted in the field for use with Propane (LP) gas. Propane gas conversion kit number WGCK-1 is designed for conversions of units installed from 0 – 6,000 feet elevations. Propane gas conversion kit number WGCK-2 is designed for conversions of units installed from 6,001 – 10,000 feet elevations. These kits may be purchased from your local distributor.



## **WARNING**

When converting from propane (LP) gas to natural gas, the gas orifice spuds and gas valve spring must be replaced and the gas valve regulator pressure must be adjusted correctly. Failure to do so can result in fire, injury or death. Refer to Table 8 for proper orifice sizing.

Natural gas spring kit, Part number 5603-007, can be purchased through your local distributor.

## **18. MANIFOLD PRESSURE ADJUSTMENT**

You will need a 0 to 15 inch water manometer with 0.1 inch resolution and a 1/8" NPT manual shut off valve to measure actual manifold pressure.



## **WARNING**

Correct manifold pressure is necessary for proper ignition and burner operation. Failure to accurately adjust pressure could cause heat exchanger failure.

1. Turn off gas at equipment shut off valve in gas supply line just ahead of furnace.
2. Remove plug from outlet pressure tap in gas control or gas manifold.
3. Install 1/8" NPT manual shut off valve in hole vacated by plug. Make sure shut off valve is in off position.
4. Attach manometer to 1/8" NPT manual shut off valve just installed.

5. Slowly open equipment shut off valve in gas supply line just ahead of furnace. Start furnace following "Operating Instructions" on front door.
6. Slowly open 1/8" NPT manual shut off valve leading to manometer.
7. Read manifold pressure on manometer.
8. Adjust manifold pressure by turning gas control regulator adjusting screw clockwise to increase pressure or turning counterclockwise to decrease pressure. Manifold pressure must be within allowable range as follows:
  - Natural gas manifold pressure must be between 3.2 and 3.8 inches W.C. Rated pressure is 3.5 inches.
  - Propane gas (LP) manifold pressure must be between 9.7 and 10.3 inches W.C. Rated pressure is 10 inches.

*NOTE: For natural gas, if gas flow rate can't be properly set within these pressure ranges then you must change main burner orifices to obtain proper gas flow rate.*

9. Shut off furnace. Turn off gas at equipment shut off valve in gas supply line just ahead of furnace. Install outlet pressure tap plug in gas control. Turn on gas.
10. Check regulator adjustment cover screw and gas control plug for gas leaks. Use a commercial soap solution made for leak detection.

## **19. CHECKING GAS INPUT RATE**

It is the installer's responsibility to see that the BTU input rate of the furnace is properly adjusted. Underfiring could cause inadequate heat, excessive condensation or ignition problems. Overfiring could cause sooting, flame impingement or overheating of heat exchanger.



## **WARNING**

Failure to adjust furnace to the proper firing rate could cause heat exchanger failure.

Depending on your local gas heating value and elevation, you may need to adjust manifold pressure or change orifices to get proper gas input rate. Check with your local gas supplier to determine heating value (BTU/cu. ft.) of natural gas in your area.

*NOTE: If furnace is being installed at an altitude of more than 6,000 feet above sea level, you must derate the furnace. See Section 20 "Standard Orifice Sizing and High Altitude Derate".*

## NATURAL GAS INPUT RATE

Natural gas heating value (BTU/cu. ft.) can vary significantly. Before starting natural gas input check, obtain gas heating value at your location from local supplier. You will need a stopwatch to measure actual gas input.

- Gas supply pressure must be between 5 and 7 inches W.C. for natural gas.
- Turn off all other gas appliances. You may leave pilots on.
- Start furnace following “Operating Instructions” on front door.
- Let furnace warm up for 6 minutes.
- Locate gas meter. Determine which dial has the least cubic feet of gas and how many cubic feet per revolution it represents. This is usually one-half, one or two cubic feet per revolution.
- With stopwatch, measure time it takes to consume two cubic feet of gas.
  - If dial is one-half cubic foot per revolution, measure time for four revolutions.
  - If dial is one cubic foot per revolution, measure time for two revolutions.
  - If dial is two cubic feet per revolution, measure time for one revolution.
- Divide this time by two. This gives average time for one cubic foot of gas to flow through meter.  
Example: If it took 58 seconds for two cubic feet to flow, it would take 29 seconds for one cubic foot to flow.
- Calculate gas input using this formula:

$$\text{Gas input} = \frac{\text{Gas Heating Value (BTU/cu. ft.)} \times 3,600 \text{ sec/hr}}{\text{Time (Seconds for one cubic foot of gas)}} = \text{BTU/hour}$$

Example:

Assume it took 29 seconds for one cubic foot of gas to flow and heating value of 1,000 BTU/cu. ft.

$$\text{Gas input} = \frac{1,000 \times 3,600}{29} = 124,138 \text{ BTU}$$

If you left no other pilots on, this is the furnace gas input.

- If you left water heater, dryer or range pilots on, allow for them in calculating correct furnace gas input. A quick way is to allow 1,000 BTU per hour for a water heater, 500 BTU per hour for dryer and 500 BTU per hour for each range burner pilot.

Example:

If you left gas water heater, dryer, two range burner pilots and one oven pilot on, allow:

Water heater pilot	1,000 BTU per hour
Dryer pilot	500 BTU per hour
2 range burner pilots	1,000 BTU per hour
1 range oven pilot	500 BTU per hour
	<hr/>
	3,000 BTU per hour

Subtracting 3,000 BTU per hour from 124,138 BTU per hour measured above equals 121,138 BTU per hour. This would be the correct furnace gas input after allowing for pilots left on.

- Manifold pressure may be adjusted within the range of 3.2 inches W.C. to 3.8 inches W.C. to get rated input  $\pm$  2 percent. See Section 18, “Manifold Pressure Adjustment”. If you cannot get rated input with manifold pressure within the allowable range, you must change orifices.

## PROPANE (LP) GAS INPUT RATE

### **WARNING**

Propane (LP) gas installations do not have gas meters to double check input rate. Measure manifold pressure adjustment with an accurate manometer. Failure to accurately adjust pressure could cause heat exchanger failure, asphyxiation, fire or explosion, resulting in damage, injury or death.

- Make sure you have proper main burner orifices.
- Gas supply pressure must be between 11 and 13 inches W.C. for propane (LP) gas.
- Start furnace following “Operating Instructions” on front door.
- Let furnace warm up for 6 minutes.
- Adjust manifold pressure to 10.0 W.C.  $\pm$  0.3 inches W.C. See Section 18, “Manifold Pressure Adjustment”.

### **WARNING**

Do not set Propane (LP) manifold pressure at 11.0 inches W.C. It could cause heat exchanger failure.



## 20. STANDARD ORIFICE SIZING AND HIGH ALTITUDE DERATE

This furnace is shipped with fixed gas orifices for use with Natural Gas and sized for 1000 BTU/cubic foot gas. Make sure actual gas input does not exceed rating plate input. You may need to change orifices to get correct gas input. Whether you do or not depends on input, and your gas heat value at standard conditions and elevation. Consult your local gas supplier for gas heat value and any special derating requirements. See Section 19 for more information.

At higher altitudes, the density of the air is reduced. Therefore, for proper combustion, the quantity of gas burned in the furnace must also be reduced. This is called derating. This unit must be derated when installed at altitudes greater than 6,000 feet above sea level. A high altitude pressure switch must also be installed for operation above 6,000 feet. High altitude pressure switch kit number 8620-189 is designed for this application.

It is the installer's responsibility to see that the furnace input rate is adjusted properly. Derating must be achieved by reducing the size of the main burner orifices. Derating the furnace by adjusting the manifold pressure lower than the range specified in the Section 18, "Manifold Pressure Adjustment" is considered to be an improper procedure.

Above 6,000 feet elevation orifice changes are required, and capacity reductions are a function of altitude impact and orifice change. Pressure switch change is required above 6,000 feet elevation. For Natural Gas see the Altitude Table 7 below and the Orifice Table 8 on following pages.

**TABLE 7  
NATURAL GAS DERATE CAPACITIES  
FOR ALL MODELS**

WF Rated Input	Sea Level	1,000	2,000	3,000	4,000	5,000	6,000	7,000	8,000	9,000	10,000
<b>41,000</b>	40,500	39,204	37,908	36,612	35,640	34,992	34,182	33,696	33,048	32,643	32,076
<b>45,000</b>	45,000	43,560	42,120	40,680	39,600	38,880	37,980	37,440	36,720	36,270	35,640
<b>61,000</b>	60,750	58,806	56,862	54,918	53,460	52,488	51,273	50,544	49,572	48,965	48,114
<b>68,000</b>	67,500	65,340	63,180	61,020	59,400	58,320	56,970	56,160	55,080	54,405	53,460
<b>75,000</b>	75,000	72,600	70,200	67,800	66,000	64,800	63,300	62,400	61,200	60,450	59,400
<b>81,000</b>	81,000	78,408	75,816	73,224	71,280	69,984	68,364	67,392	66,096	65,286	64,152
<b>90,000</b>	90,000	87,120	84,240	81,360	79,200	77,760	75,960	74,880	73,440	72,540	71,280
<b>100,000</b>	100,000	96,800	93,600	90,400	88,000	86,400	84,400	83,200	81,600	80,600	79,200
<b>113,000</b>	112,500	108,900	105,300	101,700	99,000	97,200	94,950	93,600	91,800	90,675	89,100
<b>125,000</b>	125,000	121,000	117,000	113,000	110,000	108,000	105,500	104,000	102,000	100,750	99,000



**TABLE 8  
NATURAL GAS ORIFICE TABLES  
FOR MODELS WF050 – WF125**

Factory Standard Input	Gas Heat* Value BTU/Cu. Ft.	Up to 6,000 Feet No Changes Except for BTU Content	6,001 to 8,000 Feet	8,001 to 10,000 Feet
			Requires Pressure Switch Change and Orifice Change Based on BTU Content	Requires Pressure Switch Change and Orifice Change Based on BTU Content
25000 BTU Per Burner	700-749	2.90	2.80	2.70
	750-799	2.80	2.70	2.60
	800-849	2.70	2.60	2.50
	850-899	2.60	2.50	2.45
	900-949	2.50	2.45	<b>(2.40)</b>
	950-999	2.45	<b>(2.40)</b>	2.35
	1000-1049**	<b>(2.40)</b>	2.35	<b>[2.30]</b>
	1050-1100	<b>[2.30]</b>	2.25	2.20
	Pressure Switch	Standard (.55)	<b>Order 8620-189 High Altitude Pressure Switch Kit (.42)</b>	
<b>(2.40) is the standard factory installed orifice size</b>			<b>[2.30] orifices are shipped with the unit for field installed optional 10% derate</b>	
Optional 10% Field Converted Derate	Gas Heat* Value BTU/Cu. Ft.	Up to 6,000 Feet No Changes Except for BTU Content	6,001 to 8,000 Feet	8,001 to 10,000 Feet
			Requires Pressure Switch Change and Orifice Change Based on BTU Content	Requires Pressure Switch Change and Orifice Change Based on BTU Content
22500 BTU Per Burner	700-749	2.75	2.70	2.60
	750-799	2.70	2.60	2.50
	800-849	2.60	2.50	
	850-899	2.50	2.45	<b>(2.40)</b>
	900-949	<b>(2.40)</b>	2.35	<b>[2.30]</b>
	950-999	2.35	<b>[2.30]</b>	2.25
	1000-1049**	<b>[2.30]</b>	2.25	2.20
	1050-1100	2.25	2.25	2.20
	Pressure Switch	Standard (.55)	<b>Order 8620-189 High Altitude Pressure Switch Kit (.42)</b>	
<b>[2.30] orifices are shipped with the unit for field installed optional 10% input rate.</b>			<b>(2.40) is the factory installed orifice size for full rated input</b>	

\* At standard conditions: 30.00 inches Mercury, 60F, saturated, .60 specific gravity.

\*\* All Natural Gas factory orifice sizing and standard input ratings based on nominal 1025 BTU/cu ft gas and sea level conditions

All other orifice sizes shown are available as individual items. See Orifice charts below for part numbers and number required.

Bard Part No.	Orifice Size (mm)	Orifice Diameter
9010-092	2.10	0.0826
9010-088	2.15	0.0846
9010-087	2.20	0.0866
9010-086	2.25	0.0885
9010-082	2.30	0.0905
9010-085	2.35	0.0925
9010-079	2.40	0.0945
9010-084	2.45	0.0964
9010-093	2.50	0.0984
9010-094	2.60	0.1024
9010-095	2.70	0.1063
9010-096	2.75	0.1082
9010-097	2.80	0.1102
9010-098	2.90	0.1142

No. of Orifices Required Based on Unit Input Rating
41,000 (2)
45,000 (2)
61,000 (3)
68,000 (3)
75,000 (3)
81,000 (4)
90,000 (4)
100,000 (4)
113,000 (5)
125,000 (5)

## 21. CONVERSION OF GAS INPUT BTUH FROM HIGH TO LOW RATING

All the derated WF series units are produced with maximum BTUH input orifices installed. To field convert input, a change to main burner orifices is required.

*NOTE: No change to air orifices is necessary. A set of low input orifices is shipped with every unit. They will be found packaged in a bag behind the burner door. Refer to the unit rating plate to confirm the proper orifice size. Proper installation of the orifices is detailed as follows:*

- A. Shut off electrical supply to the unit.
- B. Shut off gas supply to the unit.
- C. Remove burner access panel.
- D. Disconnect gas valve from gas supply piping.
- E. Disconnect the two wires from the gas valve.
- F. Remove the manifold assembly so that orifices are now accessible and remove orifices.
- G. Apply a modest amount of pipe compound to the new orifices and screw them into the manifold.
- H. To assemble burner reverse steps A through G.

### **WARNING**

Failure to follow these instructions could create a hazard resulting in property damage, bodily injury, or death.

## 22. MEASURING AIR TEMPERATURE RISE

Air temperature rise (supply air temperature minus return air temperature) must be within allowable air temperature rise range specified on furnace rating plate and in Table 1.

You will need 2 thermometers with 1 degree resolution capable of reading up to 200 degrees F. Check thermometers to make sure they agree, or compensate accordingly.

Follow this procedure:

1. Open supply air registers and return air grilles. Make sure the registers and grilles are free of obstruction from rugs, carpets, drapes or furniture.

2. Set balancing dampers in supply duct system.
3. Check duct work for obstructions or leaks.
4. Make sure filters are clean and in place.
5. Place one thermometer in supply air plenum approximately 2 feet from furnace. Locate thermometer tip in center of plenum to insure proper temperature measurement.
6. Place second thermometer in return air duct approximately 2 feet from furnace. Locate thermometer tip in center of duct to insure proper temperature measurement.
7. Set room thermostat on highest temperature setting. Operate furnace 10 minutes. Record supply air and return air temperatures.
8. Calculate air temperature rise by subtracting return air temperature from supply air temperature.
  - If air temperature rise is above the temperature rise range on rating plate, furnace is overfired or has insufficient airflow. Check gas input following the instructions in Section, "Checking Gas Input Rate". If air temperature rise is still above temperature rise range specified, more heating airflow is needed. Check duct work and grilles to make sure all are properly sized.
  - If air temperature rise is below the temperature rise range on rating plate, furnace is underfired or has too much airflow. Check gas input following the instructions in Section, "Checking Gas Input Rate". If air temperature rise is still below temperature rise range specified, less heating airflow is needed. Adjust dampers or grilles as needed.
  - After making adjustments, you must check air temperature rise to verify that resulting air temperature rise is within allowable range. If air temperature rise is still outside the temperature rise range specified on rating plate, check duct system design with a qualified heating engineer. It may be necessary to re-size the duct work. Recheck air temperature rise after revising duct systems.
9. Set room thermostat to desired setting.
10. Remove thermometers and seal duct work holes.

*NOTE: Failure to seal holes could result in reduced system performance.*

**FIGURE 14**  
**ACCESS INTERNAL FILTER**  
**THROUGH UPPER SERVICE DOOR**

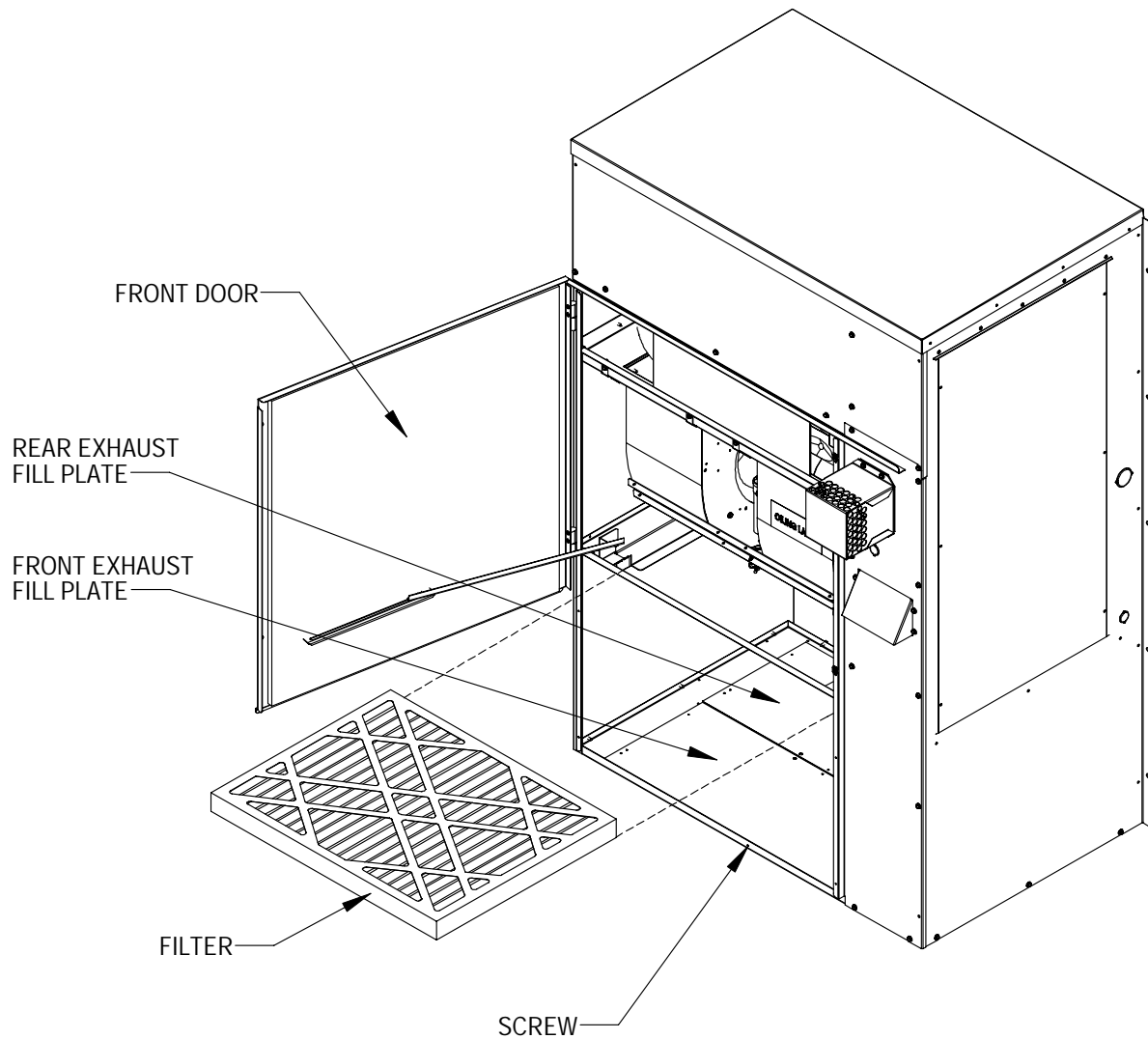

MIS-2345

### **23. FILTERS**

A 2" thick throwaway filter is supplied with each unit. This filter is installed by opening the main service door. (See Figure 14.)

Replacement filters are available through your dealer.

## 24. LIGHTING AND SHUTDOWN INSTRUCTIONS

FIGURE 15  
INSTRUCTION LABEL

### FOR YOUR SAFETY READ BEFORE OPERATING

**WARNING:** If you do not follow these instructions exactly, a fire or explosion may result causing property damage, personal injury or loss of life.

- A. This appliance does not have a pilot. It is equipped with an ignition device which automatically lights the burner. Do NOT try to light the burner by hand.
- B. BEFORE OPERATING smell all around the appliance area for gas. Be sure to smell next to the floor because some gas is heavier than air and will settle on the floor.
- WHAT TO DO IF YOU SMELL GAS**
- \*Do not try to light any appliance.
  - \*Do not touch any electric switch; do not use any phone in your building.
  - \*Immediately call your supplier from a neighbor's phone. Follow the gas supplier's instructions.
- \*If you cannot reach your gas supplier; call the fire department.
- C. Use only your hand to push in or move the gas control lever. Never use tools. If the lever will not push in or turn by hand, don't try to repair it, call a qualified service technician. Force or attempted repair may result in a fire or explosion.
- D. Do not use this appliance if any part has been under water. Immediately call a qualified service technician to inspect the appliance and to replace any part of the control system and any gas control which has been under water.

### OPERATING INSTRUCTIONS

1. STOP! Read the safety information above on this label.
  2. Set the thermostat to lowest setting.
  3. Turn off all electric power to the appliance.
  4. This appliance is equipped with an ignition device which automatically lights the burner. Do NOT try to light the burner by hand.
  5. Remove control access panel.
  6. Push in gas control knob slightly and turn clockwise to "OFF".
- NOTE: Knob cannot be turned to "OFF" unless knob is pushed in slightly. Do not force.
7. Wait five (5) minutes to clear out any gas. Then smell for gas, including near the floor. If you smell gas, STOP! Follow "B" in the safety information above on this label. If you don't smell gas, go to the next step.
  8. Turn gas control knob counterclockwise to "ON".
  9. Replace control access panel.
  10. Turn on all electric power to the appliance.
  11. Set thermostat to desired setting.
  12. If the appliance will not operate, follow the instructions "To Turn Off Gas To Appliance" and call your service technician or gas supplier.

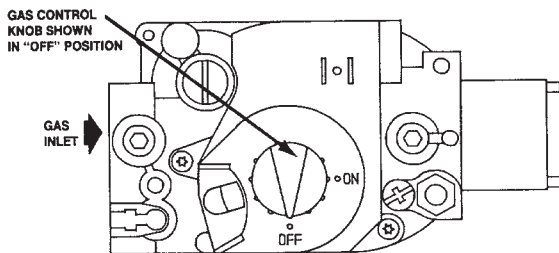

### TO TURN OFF GAS TO APPLIANCE

1. Set the thermostat to lowest setting.
2. Turn off all electric power to the appliance if service is to be performed.
3. Remove control access panel.
4. Push in gas control lever slightly and move to "OFF". Do not force.
5. Replace control access panel.

7961-509

## 25. SERVICE AGENCY PROCEDURES

### CAUTION

Label all wires prior to disconnection when servicing controls. Wiring errors can cause improper and dangerous operation. Verify proper operation after servicing.

### WARNING

Follow these procedures before inspecting furnace.

- Turn room thermostat to its lowest or off setting.
- Turn off manual gas shut off valve.
- Wait at least 5 minutes for furnace to cool if it was recently operating.
- Turn off furnace electrical power; failure to do so could result in injury or death.

#### MAIN BURNER

Observe the main burners in operation. The flame should be mostly “blue” with possibly a little orange (not yellow) at the tips of the flame. The flames should be in the center of the heat exchanger tubes and not impinging on the heat exchanger surfaces themselves.

Observe the fire until the blower starts (there is a normal delay period until the heat exchanger warms up). There should be no change in the size or shape of the flame. If there is any wavering or blowing of the flame on blower start-up, it is an indication of a possible leak in the heat exchanger.

**FIGURE 16**  
**TOP VIEW OF GAS CONTROL**

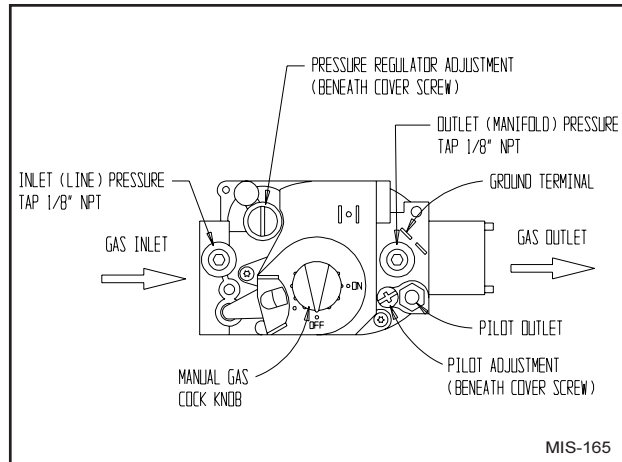

#### BURNERS / HEAT EXCHANGER / FLUE GAS PASSAGE WAYS

The burners, heat exchanger and interior flue gas passages may be inspected using a light on small mirror or an extension handle. Remove the screws securing the inducer and collector box. Now inspect the upper tubes of the heat exchanger.

Check the exterior of the heat exchanger and the interior flue gas passages for any evidence of deterioration due to corrosion, cracking or other causes. If signs of sooting exist, remove the burners and clean the heat exchanger, as required.

## 26. MAINTAINING UNIT IN GOOD WORKING ORDER

The unit should be inspected annually by a qualified service agency.

### WARNING

Use replacement parts listed in the Replacement Parts list only. The use of incorrect parts could cause improper unit operation, resulting in damage, injury or death.

## **WARNING**

Disconnect electrical power before servicing unit. Failure to do so could result in electrical shock or death.

### **ANNUAL MAINTENANCE**

Routine inspection and maintenance procedures are the responsibility of the user and are outlined below.

1. Before inspecting unit:
  - a. Turn room thermostat to lowest or off setting.
  - b. Turn off equipment gas shut off valve.
  - c. Wait for unit to cool if it was recently operating.
  - d. Turn off electrical power to unit.
2. Inspect the following:
  - a. Vent terminal and combustion air intake terminal. Make sure both are free from obstructions.
  - b. Vertical Vent Applications – Inspect venting system. Make sure system has no holes, is physically sound and free from obstructions.
  - c. Make sure the supply and return air flange sleeves or duct work are securely fastened to unit and physically sound.
  - d. Supply and return grilles must be open and free from obstructions.
  - e. Inspect to make sure the unit is securely fastened to the wall. Seal any possible leaks between unit and wall with appropriate exterior sealing material.
  - f. Inspect burners, heat exchanger, induced draft blower, and induced draft blower collector box. There must be no obvious signs of deterioration.
  - g. Inspect all electrical connections and wiring.
  - h. Check all gas piping for leaks with soap solution used to detect leaks.
  - i. Inspect, clean, and repair as needed the entire blower assembly, air filters, draft inducer, and vent options (if installed).

### **ROUTINE MAINTENANCE**

1. Air Filters – Check the condition at least monthly when the unit is in use, and replace as necessary.
2. Lubrication Requirements – The indoor circulating air blower motor is permanently lubricated and requires no re-oiling. The combustion air blower motor requires no re-oiling.

## **WARNING**

Turn off electrical power supply to prevent injury from moving parts or electric shock.

### **ROUTINE INSPECTION**

1. Inspect the physical support of the unit annually to make sure it is securely fastened to the building. Also look for any obvious signs of deterioration.
2. Inspect the main burners at the beginning of each heating season and clean as necessary.
3. Inspect the vent terminal and combustion air intake hood for any obvious deterioration, to make sure it is free and clear of any obstructions.

## **27. REPLACEMENT PARTS**

## **WARNING**

Use replacement parts listed in Replacement Parts list. Failure to do so could cause improper furnace operation, resulting in property damage, personal injury, or death.

Replacement parts for the WF units are available through local distributors.

A replacement parts list manual is supplied with each unit. When ordering parts or making inquiries pertaining to any of the units covered by these instructions, it is very important to always supply the **complete** model number and serial number of the unit. This is necessary to assure that the correct parts (or an approved alternate part) are issued to the service agency.



## 28. SEQUENCE OF OPERATION – HEATING

On a call for heat from the thermostat, the induced draft blower is energized. Once sufficient draft is established, the pressure switch contacts close and the ignition system is energized. The direct spark ignitor will be energized allowing gas to flow. At the same time the main valve is energized, a 30-second blower delay timer is activated.

After this delay, the heating speed blower relay energizes. The blower will begin operating and remain in operation until the set delay time after the call for heat has been satisfied. This timing sequence guarantees blower on, blower off operation.

This unit is equipped with a flame roll-out switch, which is wired in series with the control circuit. This is a manual reset switch and is used for the purpose of preventing possible fire hazard in the event of a system malfunction. If this switch has opened the control circuit, there could be a possible system malfunction. Some of the conditions that might cause a roll-out to occur are blockage or sooting of primary heat exchanger, overfiring of furnace due to improper main burner orifices or incorrect manifold pressure, insufficient combustion air, or installation deficiencies with respect to return air duct design or sizing.

Once the problem has been resolved, reset the switch by pressing down on the reset button on top of the switch. See Figure 17 for additional information.

**FIGURE 17  
SEQUENCE OF OPERATION  
ELECTRONIC BLOWER CONTROL**

<b>ACTION</b>	<b>SYSTEM RESPONSE</b>
Thermostat calls for heat. (W terminal is energized.)	<ul style="list-style-type: none"> <li>• Combustion air blower is energized.</li> <li>• Air proving switch makes. Air flow is established.</li> <li>• Ignition system is energized.</li> <li>• Gas valve opens and main burner lights.</li> <li>• Heat fan on delay timing begins. When timing is complete, the circulating fan is energized at heat speed.</li> </ul>
Thermostat ends call for heat.	<ul style="list-style-type: none"> <li>• Ignition system is de-energized and gas valve closes.</li> <li>• Combustion air blower is de-energized after postpurge timing.</li> <li>• Heat fan off delay timing begins. When timing is complete, the circulating fan is de-energized.</li> </ul>
Thermostat begins call for fan. (G terminal is de-energized.)	<ul style="list-style-type: none"> <li>• Circulating fan is energized on heating speed.</li> </ul>
Limit (flame rollout) opens.	<ul style="list-style-type: none"> <li>• Thermostat and ignition system are de-energized and gas valve closes.</li> <li>• Combustion air blower and circulating fan heat speed are energized.</li> </ul>
Limit (auto reset) or flame rollout (manual reset) circuit closed.	<ul style="list-style-type: none"> <li>• Combustion air blower remains energized for postpurge timing.</li> <li>• The circulation fan remains energized for the selected delay off timing.</li> <li>• Normal operation resumes.</li> </ul>

## 29. INDOOR BLOWER OPERATION

All models have multiple speed direct drive blower motors. If supply and return ducts are connected to the unit, the ducts must be of adequate size.

If voltage and duct design permit, (see blower tables) single speed operation can be achieved as follows:

### BLOWER MOTOR SPEED CHANGE

1. Disconnect power supply to unit.
2. Place desired blower motor speed lead wire to "HEAT" terminal of integrated furnace control board.

3. Place unused blower motor speed lead wire to "UNUSED" terminal of integrated furnace control board.
4. Energize the system in heating mode to check for proper blower operation.

**TABLE 9  
115 & 230 VOLT MOTOR SPEED TAPS**

<b>Speeds</b>	<b>3-Speed Blower Motor</b>
Low	Red
Medium	Blue
High	Black

**TABLE 10**  
**INTEGRATED FURNACE AND BLOWER CONTROL OPERATION**

**IGNITION SEQUENCE CONTROL**

Ignition Source	24 VAC DSI
Flame Sensing	Remote
Timings	
- Prepurge	15 seconds
- Postpurge	30 seconds (0 if cycle terminated before valve "on")
- Inter-trial purge	15 seconds
- Pressure switch proving period	60 seconds
- Trials for ignition	3 per ignition sequence
- Trial for ignition	7 seconds total time to prove flame
- Ignition sequence lockout	60 minutes (after 3 trials for ignition), auto reset - can be reset during the 60 minute lockout period by opening thermostat circuit for 3 seconds or more
- Heat blower on - delay	30 seconds (timing starts when ignitor cycles off)
- Heat blower off - delay	90, 120, 150 seconds selectable; factory set at 120
- Manual fan operations	Operates on selected heating speed and cycles off during ignition or burner start up sequence.
- High limit control operation	Automatic reset, ignition sequence restart. See Note 1.
- Flame rollout switch operation	Manual reset, ignition sequence initiated after switch is manually reset. See Note 1.

*NOTE 1: After the fourth limit trip on a given call for heat there will be a 1 hour delay before the ignition sequence will restart. After either high limit switch or flame rollout switch actuation the inducer will operate for the 30 second post purge and the comfort air blower will operate for the selected off delay. If on Manual Fan operation, the comfort air blower will continue to operate.*

**SAFETY UNITS**

High limit / Rollout Pressure switch	SPST in 24 Volt SPST, safe start check
--------------------------------------	---

**COMFORT FAN CONTROL**

**Heating Speed Fan**

Normal operation	
- ON delay	30 seconds fixed. Timing starts when igniter de-energized
- OFF delay	3 selectable timings -120 seconds standard can be changed to 90 or 150 seconds. ON when limit OPEN OFF after OFF delay when limit CLOSES
Limit Operation	ON if flame is sensed <b>and</b> there is no call for heat.
Flame Sense	

**Manual Fan**

ON continuously on HEATING speed.

**DIAGNOSTIC INDICATOR**

A red LED is provided to indicate system faults as follows:

- Steady ON - Control okay in standby, call for heat, cool or fan modes
- Steady OFF - Internal control fault or no power. Also check 3A fuse on control.
- 1 flash - Lockout due to failed ignition or flame dropouts
- 2 flashes - Pressure switch open with inducer on
- 3 flashes - Pressure switch is closed with inducer off
- 4 flashes - Limit switch is open
- 5 flashes - Flame detected with gas valve closed

The flash rate is 0.25 seconds on, 0.25 seconds off with 2.0 seconds pause between flash codes.  
The flash rate is 0.25 seconds on, 0.25 seconds off with 2.0 seconds pause between flash codes.



**30. LOW-NOX BURNER ASSEMBLY “N”  
SUFFIX MODELS ONLY – U.S.  
INSTALLATIONS ONLY**

**NATURAL GAS MODELS ONLY**

Model numbers designated with an “N” are designed for low NOx emissions which comply with all California Air Quality Management District regulations for nitrogen oxide emission levels. Refer to Figure 18 for NOx insert information.

**\*\* IMPORTANT \*\***

For propane (LP) conversions the NOx reduction screen inserts shown below must be removed. This is accomplished by removing the burner box assembly and removing the NOx screens. Reassemble unit properly before firing. Failure to remove the NOx screens can result in improper operation and malfunction of the burner system.

**FIGURE 18  
LOW NOX INSERT**

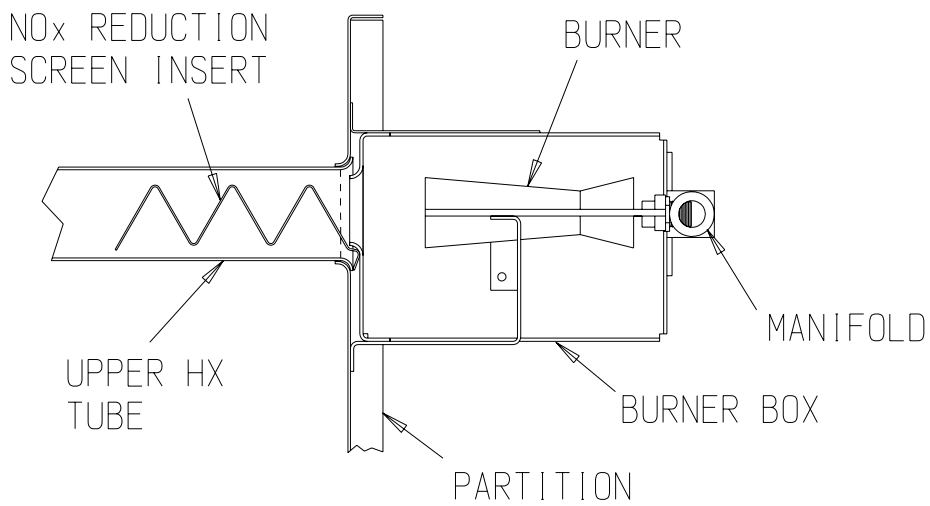

MIS-1481

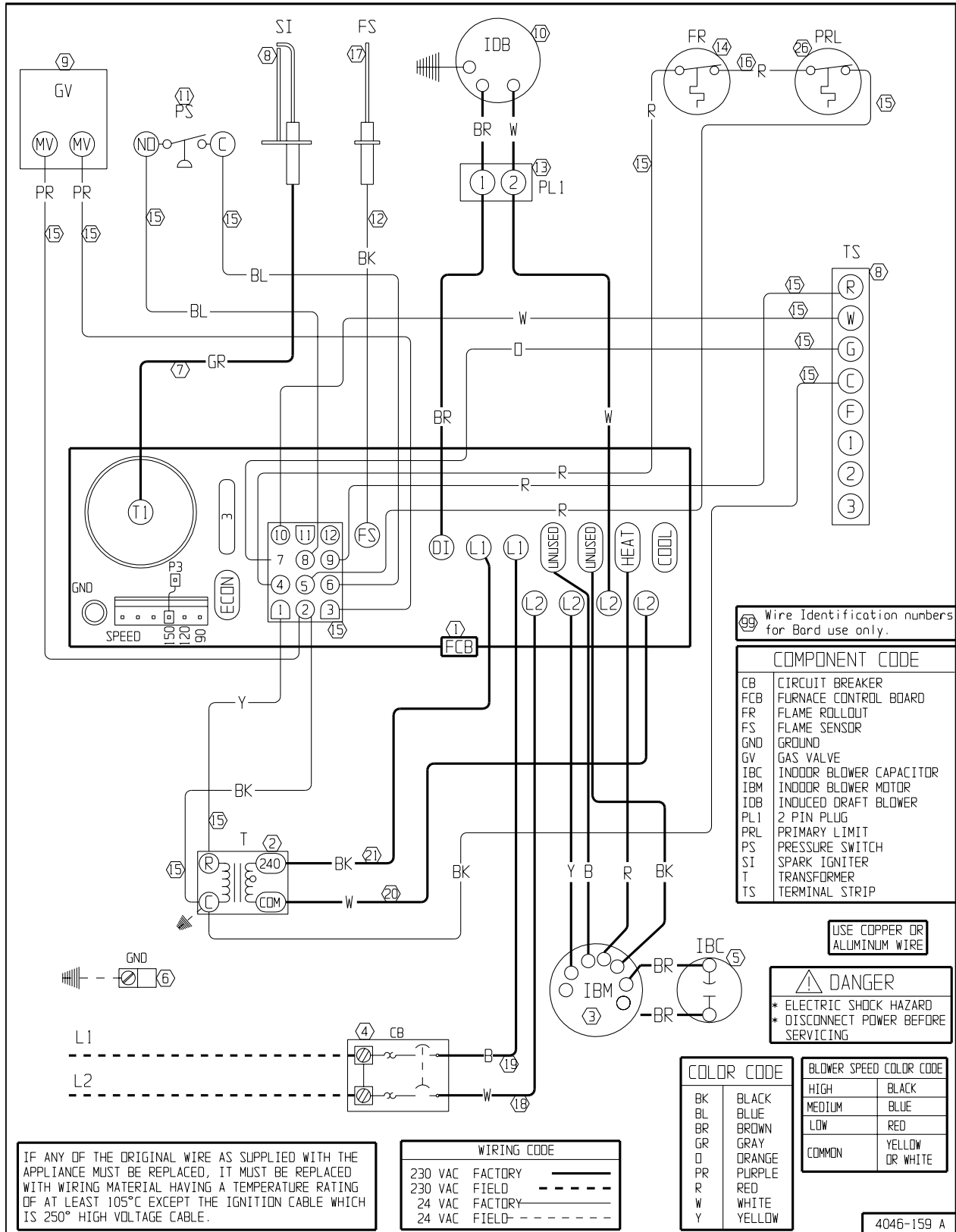

230/208-60-1

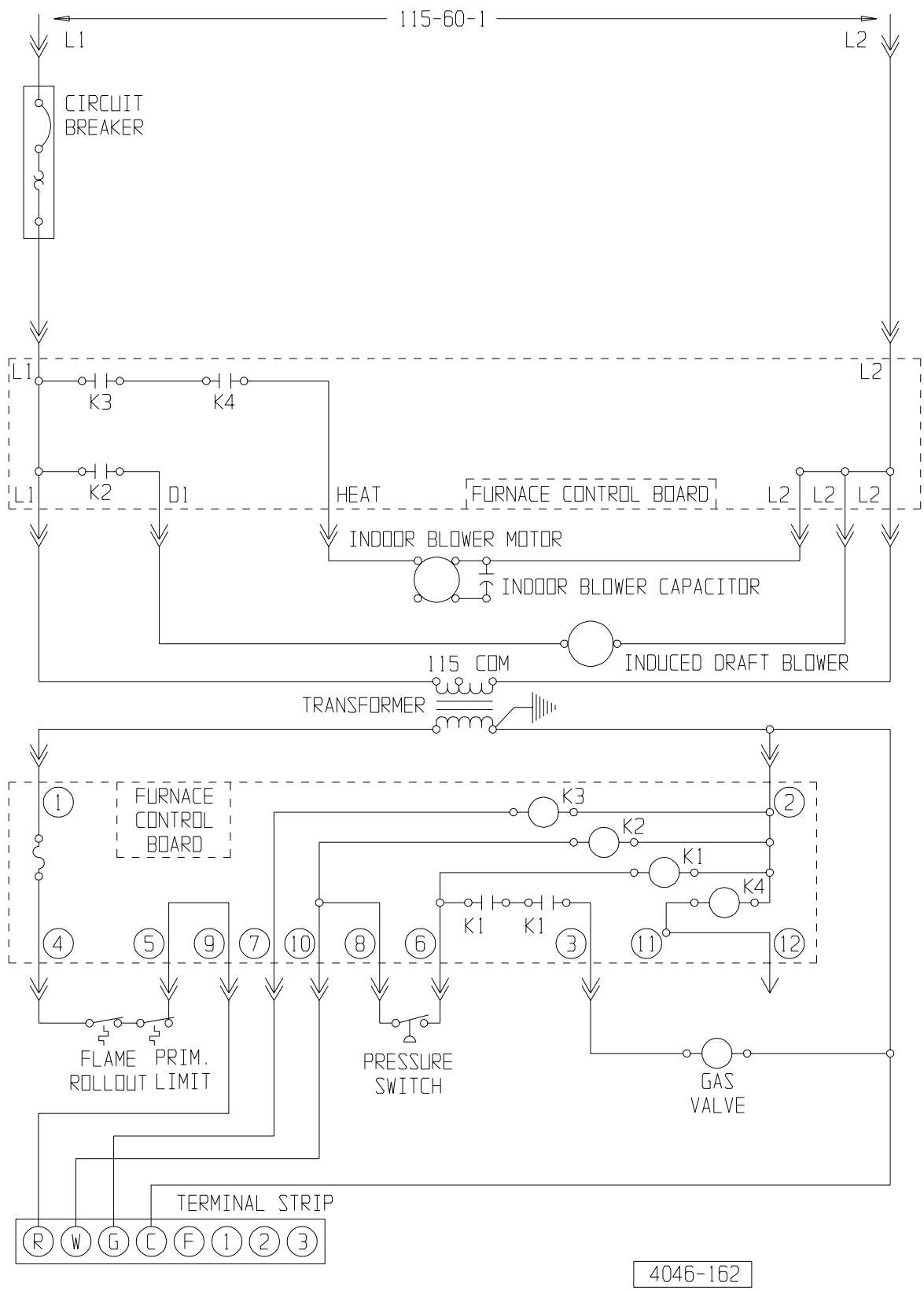

**115-60-1**

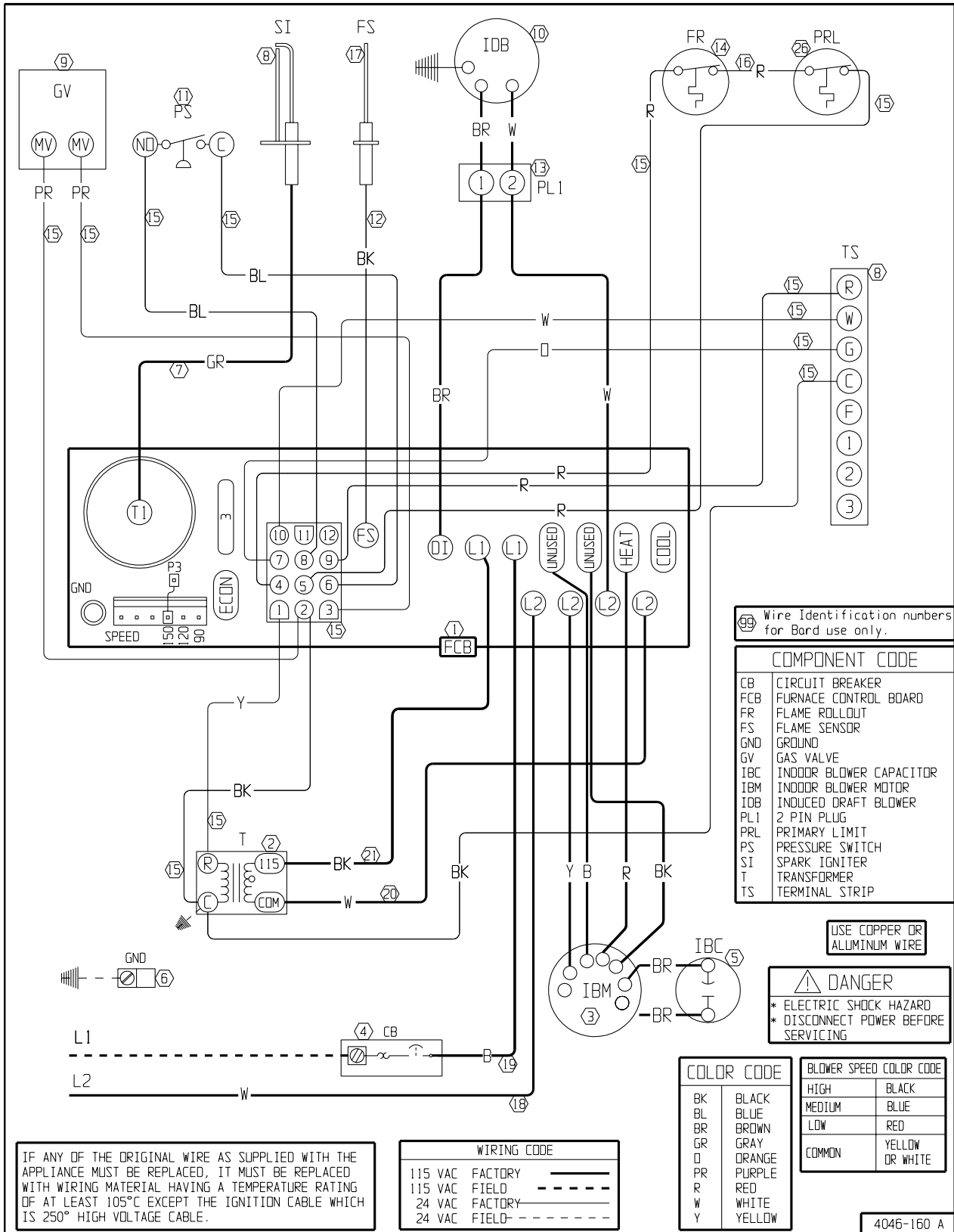

115-60-1

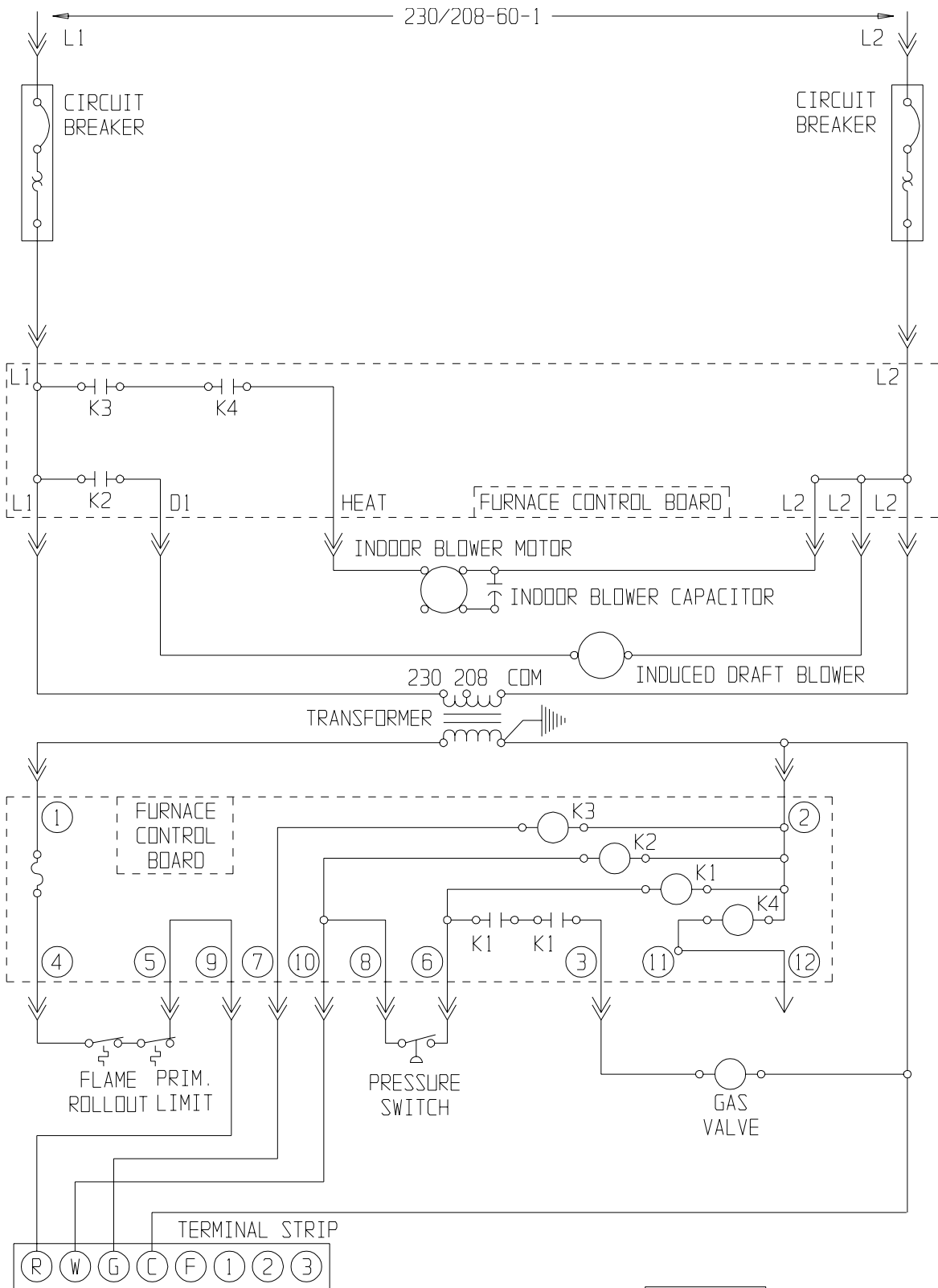

4046-161

**230/208-60-1**