

---

# INSTALLATION INSTRUCTIONS

---

## WALL MOUNTED PACKAGE HEAT PUMPS

**MODELS:  
WH423D  
WH484D  
WH604D**



Bard Manufacturing Company, Inc.  
Bryan, Ohio 43506  
*Since 1914...Moving ahead just as planned.*

Manual : 2100-488  
Supersedes: *NEW*  
File: Volume III Tab 17  
Date: 01-04-08

# Contents

---

## Getting Other Informations and Publications

For more information, contact these publishers: ..... 3

## Wall Mount General Information

Heat Pump Wall Mount Model Nomenclature ..... 4  
Shipping Damage ..... 7  
General ..... 7  
Duct Work ..... 7  
Filters ..... 7  
Fresh Air Intake ..... 8  
Condensate Drain ..... 8

## Installation Instructions

Wall Mounting Information ..... 9  
Mounting the Unit ..... 9  
Typical Installations ..... 9  
Wiring – Main Power ..... 13  
Wiring – Low Voltage ..... 13  
Low Voltage Connections ..... 13  
Thermostat Indicators ..... 16

## Figures

Figure 1 Unit Dimensions ..... 5  
Figure 2 Blower Damper Assembly ..... 8  
Figure 3 Mounting Instructions ..... 10  
Figure 4 Electric Heat Clearance ..... 10  
Figure 5 Wall Mounting Instructions ..... 11  
Figure 6 Wall Mounting Instructions ..... 11  
Figure 7 Common Wall Mounting Installations .... 12  
Figure 8 Hot Gas Reheat During  
Dehumidification with CS2000A ..... 14  
Figure 9 Hot Gas Reheat During  
Dehumidification with  
Programmable Thermostat ..... 15  
Figure 10 Start Up Label ..... 17  
Figure 11 Defrost Control Board ..... 19  
Figure 12 Fan Blade Setting ..... 22  
Figure 13 Circuit Diagram Heat Pump  
Cooling Mode ..... 26  
Figure 14 Circuit Diagram Heat Pump  
Dehumidification Mode ..... 26

## Start Up

Important Installer Note ..... 17  
Crankcase Heaters ..... 17  
High Pressure Switch ..... 17  
Three Phase Scroll Compressor Start Up ..... 17  
Phase Monitor ..... 18  
Service Hints ..... 18  
Sequence of Operation ..... 18  
Pressure Service Ports ..... 18  
Defrost Cycle ..... 19

## Troubleshooting

Solid State Heat Pump Control  
Troubleshooting Procedure ..... 20  
Checking Temperature Sensor  
Outside Unit Circuit ..... 21  
Temperature vs. Resistance of  
Temperature Sensor ..... 21  
Fan Blade Dimensions ..... 22  
Removal of Fan Shroud ..... 22  
Refrigerant Charge ..... 22  
Pressure Tables ..... 23-24  
Optional Accessories ..... 24

## Tables

Table 1 Electric Heat Table ..... 4  
Table 2 Electrical Specifications ..... 6  
Table 3 Thermostat Wire Size ..... 16  
Table 4 Wall Thermostats ..... 16  
Table 5 Troubleshooting ..... 20  
Table 6 Fan Blade Dimensions ..... 22  
Table 7 Suction Line Temperatures ..... 22  
Table 8 Recommended Operating Ranges ..... 22  
Table 9 Indoor Blower Performance ..... 22  
Table 10 Maximum ESP of Operation ..... 23  
Table 11 Pressure Table – Cooling ..... 23  
Table 12 Pressure Table – Heating ..... 24  
Table 13 Optional Accessories ..... 24  
Table 14 Dehumidification Relay Logic Board .... 25

# Getting Other Information and Publications

---

These publications can help you install the air conditioner or heat pump. You can usually find these at your local library or purchase them directly from the publisher. Be sure to consult current edition of each standard.

National Electrical Code ..... ANSI/NFPA 70

Standard for the Installation ..... ANSI/NFPA 90A  
of Air Conditioning and Ventilating Systems

Standard for Warm Air ..... ANSI/NFPA 90B  
Heating and Air Conditioning Systems

Load Calculation for ..... ACCA Manual J or N  
Residential Winter and Summer Air Conditioning

Low Pressure, Low Velocity ..... ACCA Manual D or Q  
Duct System Design for Winter and Summer Air  
Conditioning

For more information, contact these publishers:

**ACCA**    **Air Conditioning Contractors of America**  
1712 New Hampshire Ave. N.W.  
Washington, DC 20009  
Telephone: (202) 483-9370  
Fax: (202) 234-4721

**ANSI**    **American National Standards Institute**  
11 West Street, 13th Floor  
New York, NY 10036  
Telephone: (212) 642-4900  
Fax: (212) 302-1286

**ASHRAE**    **American Society of Heating Refrigerating  
and Air Conditioning Engineers, Inc.**  
1791 Tullie Circle, N.E.  
Atlanta, GA 30329-2305  
Telephone: (404) 636-8400  
Fax: (404) 321-5478

**NFPA**    **National Fire Protection Association**  
Batterymarch Park  
P.O. Box 9101  
Quincy, MA 02269-9901  
Telephone: (800) 344-3555  
Fax: (617) 984-7057

# WALL MOUNT GENERAL INFORMATION

## Heat Pump Wall Mount Model Nomenclature

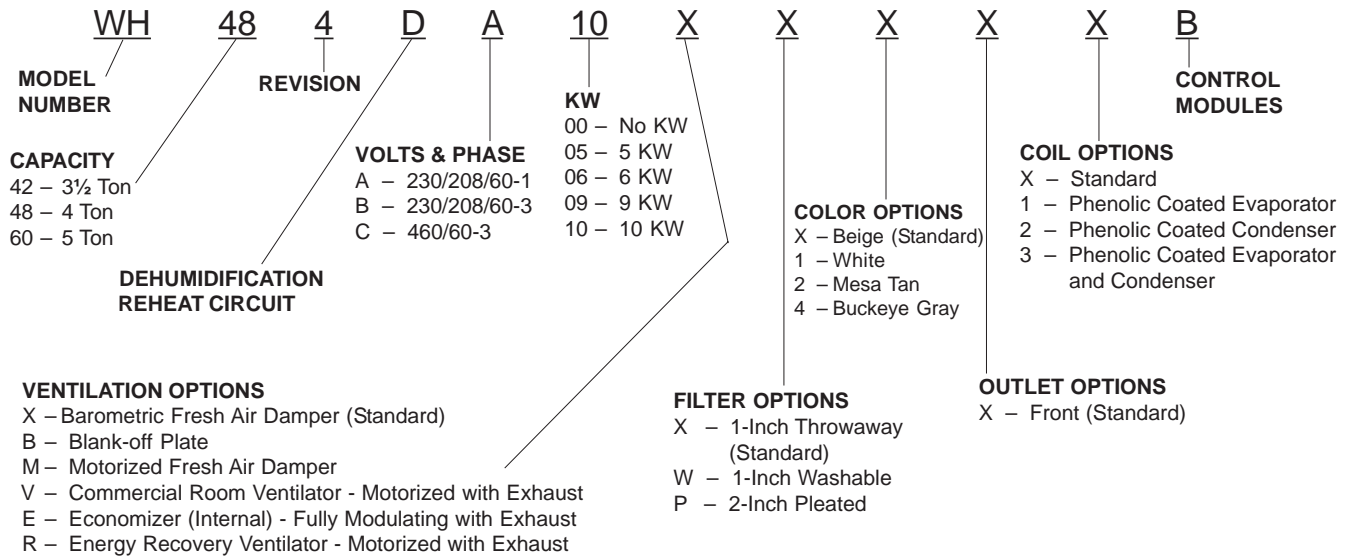

NOTE: For 0 KW and circuit breakers (230/208V) or pull disconnects (460V) applications, insert 0Z in the KW field of model number.

**TABLE 1  
ELECTRIC HEAT TABLE**

Models	WH423DA				WH423DB WH484DB				WH423DC		WH484DA WH604DA				WH484DB WH604DB				WH484DC WH604DC	
	240-1		208-1		240-3		208-3		460-3		240-1		208-1		240-3		208-3		460-3	
	A	BTU	A	BTU	A	BTU	A	BTU	A	BTU	A	BTU	A	BTU	A	BTU	A	BTU	A	BTU
5	20.8	17065	18.1	12800							20.8	17065	18.1	12800						
6					14.4	20500	12.5	15360	7.2	20480										
9					21.7	30600	18.7	23030	10.8	30700					21.7	30600	18.7	23030	10.8	30700
10	41.6	34130	36.2	25600							41.6	34130	36.2	25600						

**FIGURE 1  
UNIT DIMENSIONS**

SIZE SPECS FOR MIS-411

UNIT	WIDTH (W)	DEPTH (D)	HEIGHT (H)	SUPPLY			RETURN			E	F	G	I	J	K	L	M	N	O	P	Q
				A	B	C	B	C													
42-48-60	42	22-1/4	84-7/8	9-7/8	29-7/8	15-7/8	29-7/8	43-7/8	19	31-5/8	30	32-11/16	27	34-3/4	32-1/2	3-1/4	43	23-7/8	10		

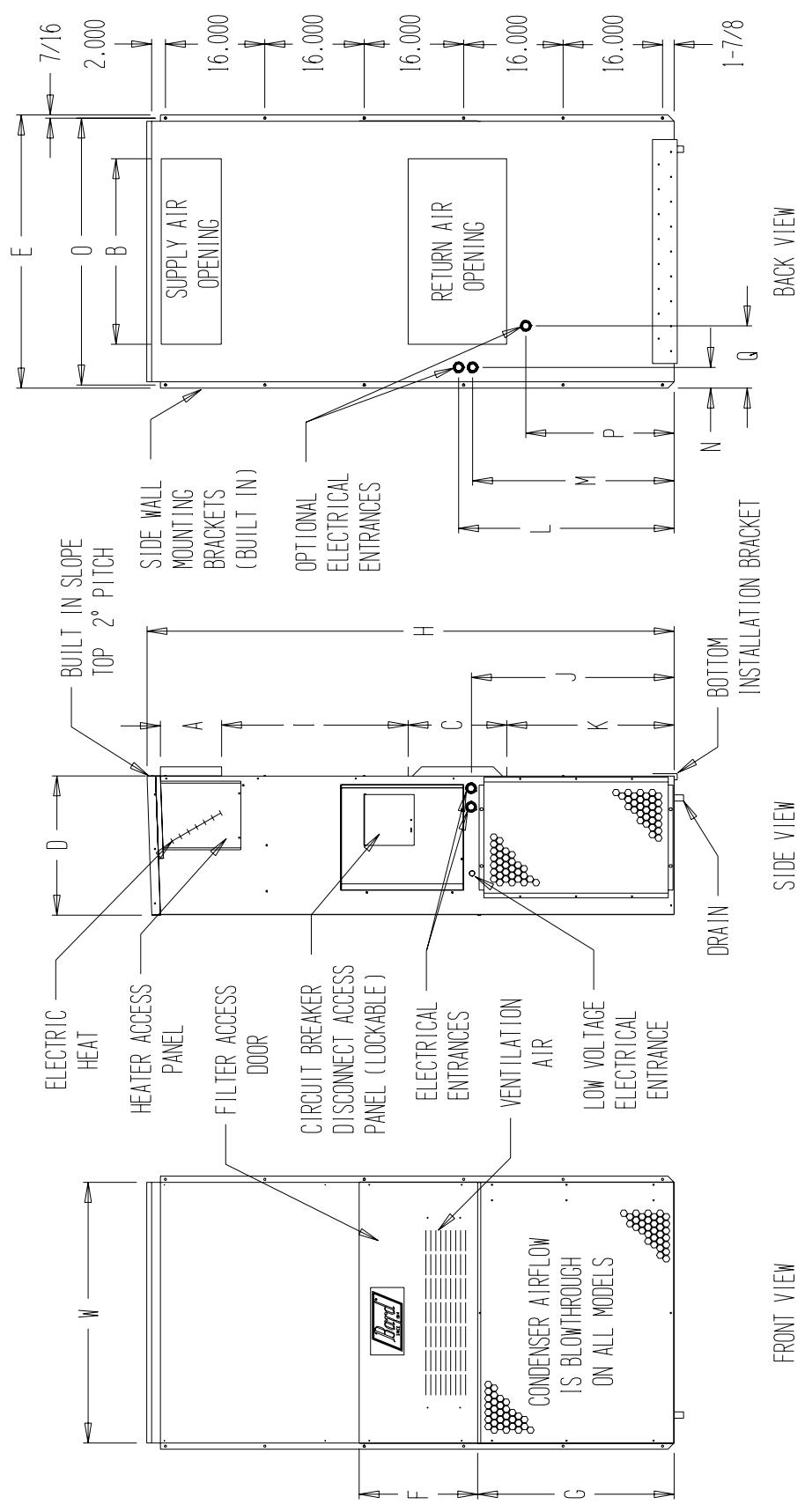

**TABLE 2  
ELECTRICAL SPECIFICATIONS**

Model	SINGLE CIRCUIT						DUAL CIRCUIT							
	Rated Volts & Phase	No. Field Power Ckts.	④	①	②	②	④		①		②		②	
			Minimum Circuit Ampacity	Maximum External Fuse or Circuit Breaker	Field Power Wire Size	Ground Wire Size	Minimum Circuit Ampacity	Maximum External Fuse or Ckt. Breaker	Field Power Wire Size	Ground Wire Size	Ckt A	Ckt B	Ckt A	Ckt B
WH423DA00, A0Z A05 ③ A10	230/208-1	1 1 or 2 1 or 2	34 60 86	50 70 90	8 6 3	10 8 8	N/A 34 34	N/A 26 52	N/A 50 50	N/A 30 60	N/A 8 8	N/A 10 6	N/A 10 10	N/A 10 10
WH423DB00, B0Z B06 ③ B09	230/208-3	1 1 1	26 44 53	35 50 60	8 8 6	10 10 10	N/A N/A N/A	N/A N/A N/A	N/A N/A N/A	N/A N/A N/A	N/A N/A N/A	N/A N/A N/A	N/A N/A N/A	N/A N/A N/A
WH423DC00, C0Z C06 ③ C09	460-3	1 1 1	13 23 27	20 25 30	12 10 10	12 10 10	N/A N/A N/A	N/A N/A N/A	N/A N/A N/A	N/A N/A N/A	N/A N/A N/A	N/A N/A N/A	N/A N/A N/A	N/A N/A N/A
WH484DA00, A0Z A05 ③ A10	230/208-1	1 1 or 2 1 or 2	38 64 90	50 80 100	8 6 3	10 8 8	N/A 38 38	N/A 26 52	N/A 60 60	N/A 30 60	N/A 8 8	N/A 10 6	N/A 10 10	N/A 10 10
WH484DB00, B0Z B06 ③ B09	230/208-3	1 1 1	27 45 54	35 50 60	8 8 6	10 10 10	N/A N/A N/A	N/A N/A N/A	N/A N/A N/A	N/A N/A N/A	N/A N/A N/A	N/A N/A N/A	N/A N/A N/A	N/A N/A N/A
WH484DC00, C0Z ③ C09	460-3	1 1	15 28	20 30	12 10	12 10	N/A N/A	N/A N/A	N/A N/A	N/A N/A	N/A N/A	N/A N/A	N/A N/A	N/A N/A
WH604DA00, A0Z A05 ③ A10	230/208-1	1 1 or 2 1 or 2	45 71 97	60 90 110	8 4 3	10 8 6	N/A 45 45	N/A 26 52	N/A 60 60	N/A 60 60	N/A 8 8	N/A 10 6	N/A 10 10	N/A 10 10
WH604DB00, B0Z ③ B09	230/208-3	1 1	33 60	45 60	8 6	10 10	N/A N/A	N/A N/A	N/A N/A	N/A N/A	N/A N/A	N/A N/A	N/A N/A	N/A N/A
WH604DC00, C0Z ③ C09	460	1 1	16 29	20 35	12 8	12 10	N/A N/A	N/A N/A	N/A N/A	N/A N/A	N/A N/A	N/A N/A	N/A N/A	N/A N/A

① Maximum size of the time delay fuse or HACR type circuit breaker for protection of field wiring conductors.

② Based on 75°C copper wire. All wiring must conform to NEC and all local codes.

③ Maximum KW that can operate with heat pump on. These "Minimum Circuit Ampacity" values are to be used for sizing the field power conductors. Refer to the National Electrical Code (latest version), article 310 for power conductor sizing.

**CAUTION:** *When more than one field power conductor circuit is run through one conduit, the conductors must be derated. Pay special attention to note 8 of table 310 regarding Ampacity Adjustment Factors when more than 3 conductors are in a raceway.*

## SHIPPING DAMAGE

Upon receipt of equipment, the carton should be checked for external signs of shipping damage. If damage is found, the receiving party must contact the last carrier immediately, preferably in writing, requesting inspection by the carrier's agent.

## GENERAL

The equipment covered in this manual is to be installed by trained, experienced service and installation technicians.

The refrigerant system is completely assembled and charged. All internal wiring is complete.

The unit is designed for use with or without duct work. Flanges are provided for attaching the supply and return ducts.

These instructions and any instructions packaged with any separate equipment required to make up the entire heat pump system should be carefully read before beginning the installation. Note particularly "Starting Procedure" and any tags and/or labels attached to the equipment.

While these instructions are intended as a general recommended guide, they do not supersede any national and/or local codes in any way. Authorities having jurisdiction should be consulted before the installation is made. See Page 3 for information on codes and standards.

Size of unit for a proposed installation should be based on heat loss calculation made according to methods of Air Conditioning Contractors of America (ACCA). The air duct should be installed in accordance with the Standards of the National Fire Protection Association for the Installation of Air Conditioning and Ventilating Systems of Other Than Residence Type, NFPA No. 90A, and Residence Type Warm Air Heating and Air Conditioning Systems, NFPA No. 90B. Where local regulations are at a variance with instructions, installer should adhere to local codes.

## DUCT WORK

Any heat pump is more critical of proper operating charge and an adequate duct system than a straight air conditioning unit. All duct work, supply and return, must be properly sized for the design airflow requirement of the equipment. Air Conditioning Contractors of America (ACCA) is an excellent guide to proper sizing. All duct work or portions thereof not in the conditioned space should be properly insulated in order to both conserve energy and prevent condensation or moisture damage.

Refer to Table 10 for maximum static pressure available for duct design.

Design the duct work according to methods given by the Air Conditioning Contractors of America (ACCA). When duct runs through unheated spaces, it should be insulated with a minimum of one inch of insulation. Use insulation with a vapor barrier on the outside of the insulation. Flexible joints should be used to connect the duct work to the equipment in order to keep the noise transmission to a minimum.

A 1/4 inch clearance to combustible material for the first three feet (3') of duct attached to the outlet air frame is required. See Wall Mounting Instructions and Figures 3, 4, 5 and 6 for further details.

Ducts through the walls must be insulated and all joints taped or sealed to prevent air or moisture entering the wall cavity.



## CAUTION

Some installations may not require any return air duct. A metallic return air grille is required with installations not requiring a return air duct. The spacing between louvers on the grille shall not be larger than 5/8 inches.

Any grille that meets the 5/8 inch louver criteria, may be used. It is recommended that Bard Return Air Grille Kit RG-2 through RG-5 or RFG-2 through RFG-5 be installed when no return duct is used. Contact distributor or factory for ordering information. If using a return air filter grille, filters must be of sufficient size to allow a maximum velocity of 400 fpm.

*NOTE: If no return air duct is used, applicable installation codes may limit this cabinet to installation only in a single story structure.*

## FILTERS

A 1-inch throwaway filter is supplied with each unit. The filter slides into position making it easy to service. This filter can be serviced from the outside by removing the service door. A 1-inch washable filter and 2-inch pleated filter are also available as optional accessories. The internal filter brackets are adjustable to accommodate the 2-inch filter by bending down the tabs to allow spacing for the 2-inch filters.

## FRESH AIR INTAKE

All units are built with fresh air inlet slots punched in the service panel.

If the unit is equipped with the fresh air damper assembly, the assembly is shipped already attached to the unit. The damper blade is locked in the closed position. To allow the damper to operate, the maximum and minimum blade position stops must be installed. See Figure 2.

All capacity, efficiency and cost of operation information as required for Department of Energy "Energyguide" Fact Sheets is based upon the fresh air blank-off plate in place and is recommended for maximum energy efficiency.

The blank-off plate is available upon request from the factory and is installed in place of the fresh air damper shipped with each unit.

## CONDENSATE DRAIN

A plastic drain hose extends from the drain pan at the top of the unit down to the unit base. There are openings in the unit base for the drain hose to pass through. In the event the drain hose is connected to a drain system of some type, it must be an open or vented type system to assure proper drainage.

**FIGURE 2  
BLOWER DAMPER ASSEMBLY**

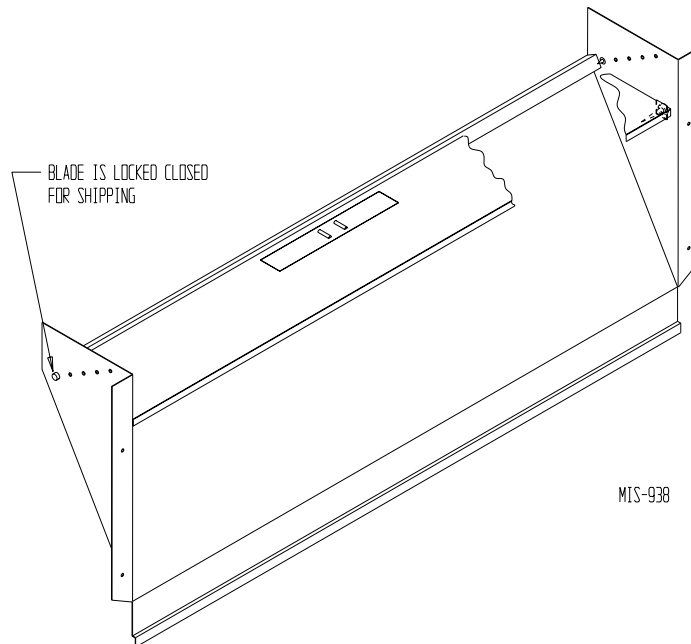



# INSTALLATION INSTRUCTIONS

## WALL MOUNTING INFORMATION

1. Two holes, for the supply and return air openings, must be cut through the wall as shown in Figure 3.
2. On wood-frame walls, the wall construction must be strong and rigid enough to carry the weight of the unit without transmitting any unit vibration. See Figures 5 and 6.



## WARNING

Fire hazard can result if 1/4 inch clearance to combustible materials for supply air duct is not maintained. See Figure 3.

3. Concrete block walls must be thoroughly inspected to insure that they are capable of carrying the weight of the installing unit. See Figure 4.

## MOUNTING THE UNIT

1. These units are secured by wall mounting brackets, which secure the unit to the outside wall surface at both sides. A bottom mounting bracket is provided for ease of installation, but it is not required.
2. The unit itself is suitable for "0" inch clearance, but the supply air duct flange and the first 3 feet of supply air duct require a minimum of 1/4 inch clearance to combustible material. If a combustible wall, use a minimum of 30½" x 10½" dimensions for sizing. However, it is generally recommended that a 1-inch clearance is used for ease of installation and maintaining the required clearance to combustible material. The supply air opening would then be 32" x 12". See Figures 3, 4 and 7 for details.



## WARNING

Failure to provide the 1/4 inch clearance between the supply duct and a combustible surface for the first 3 feet of duct can result in fire.

3. Locate and mark lag bolt locations and bottom mounting bracket location. See Figure 4.
4. Mount bottom mounting bracket.
5. Hook top rain flashing under back bend of top. Top rain flashing is shipped secured to the right side of the back.
6. Position unit in opening and secure with 5/16 lag bolts; use 7/8 inch diameter flat washers on the lag bolts.
7. Secure rain flashing to wall and caulk across entire length of top. See Figure 3.
8. For additional mounting rigidity, the return air and supply air frames or collars can be drilled and screwed or welded to the structural wall itself (depending upon wall construction). Be sure to observe required clearance if combustible wall.
9. On side-by-side installations, maintain a minimum of 20 inches clearance on right side to allow access to heat strips and control panel, and to allow proper airflow to the outdoor coil. Additional clearance may be required to meet local or national codes.

## TYPICAL INSTALLATIONS

See Figure 7 for common ways to install the Wall Mount unit.

**FIGURE 3  
MOUNTING INSTRUCTIONS**

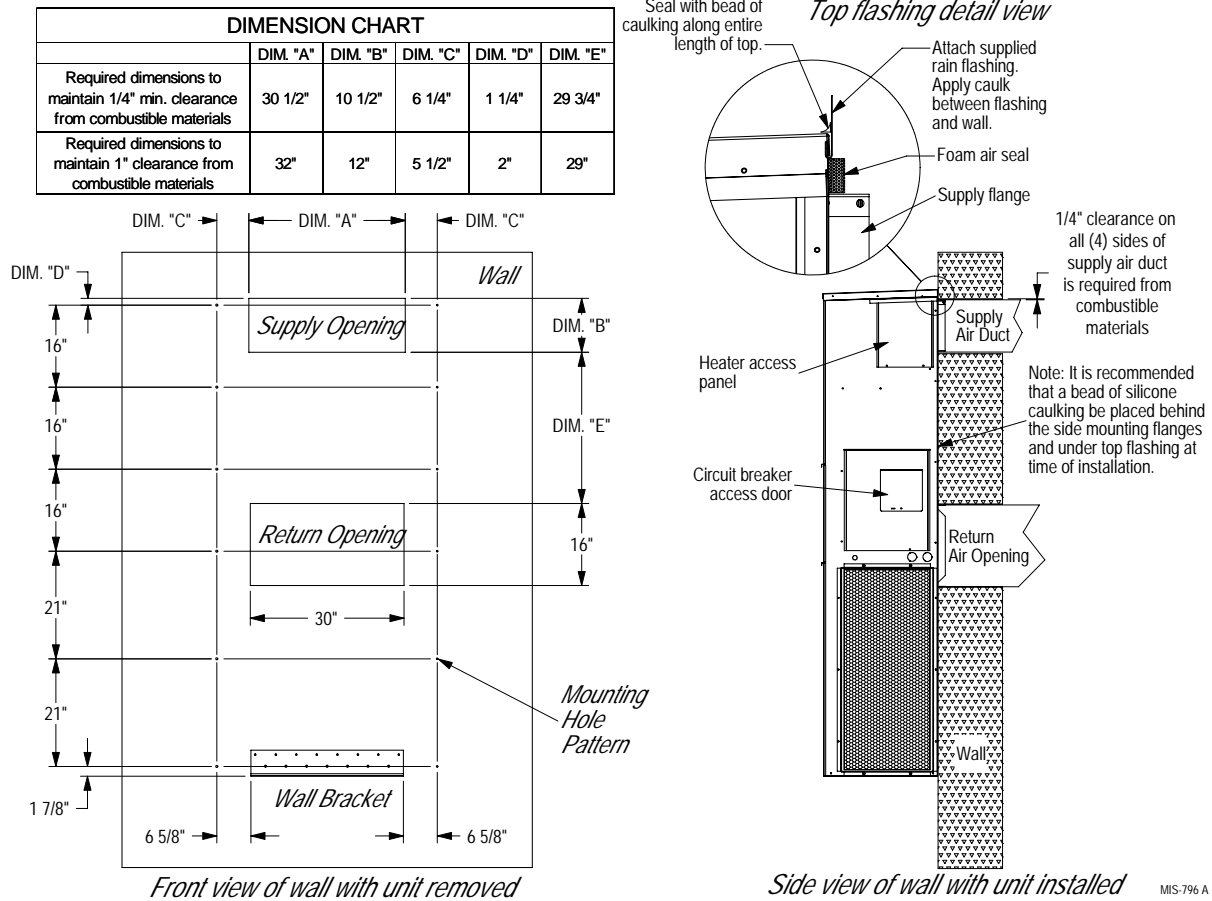

**FIGURE 4  
ELECTRIC HEAT CLEARANCE**

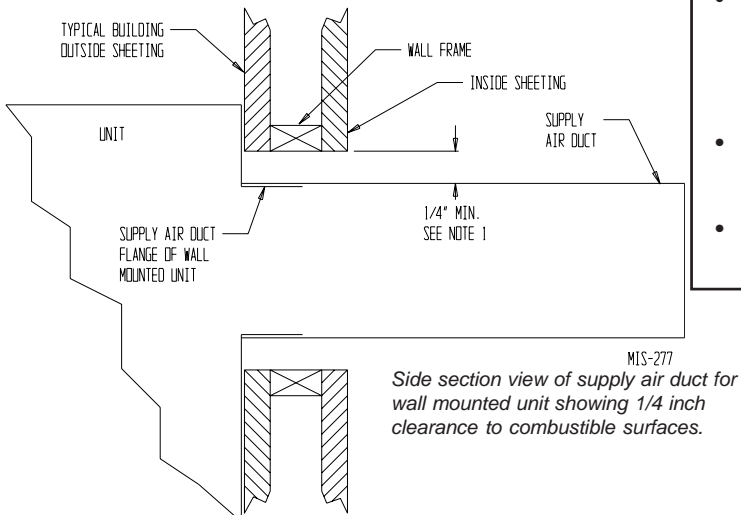

## ⚠ WARNING

- A **minimum** of 1/4 inch clearance must be maintained between the supply air duct and combustible materials. This is required for the first 3 feet of ducting.
- It is important to insure that the 1/4 inch minimum spacing is maintained at all points.
- Failure to do this could result in overheating the combustible material and may result in fire.

## FIGURE 5 WALL-MOUNTING INSTRUCTIONS

SEE FIGURE 3 — MOUNTING INSTRUCTIONS

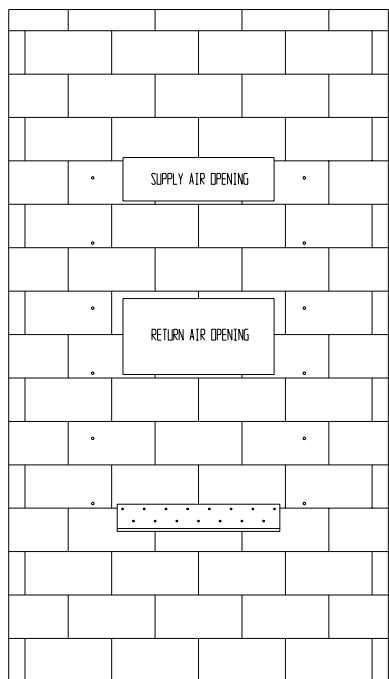

CONCRETE BLOCK WALL INSTALLATION

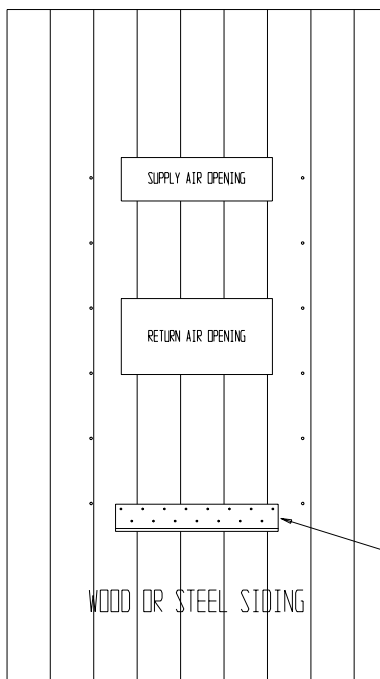

WOOD FRAME WALL INSTALLATION

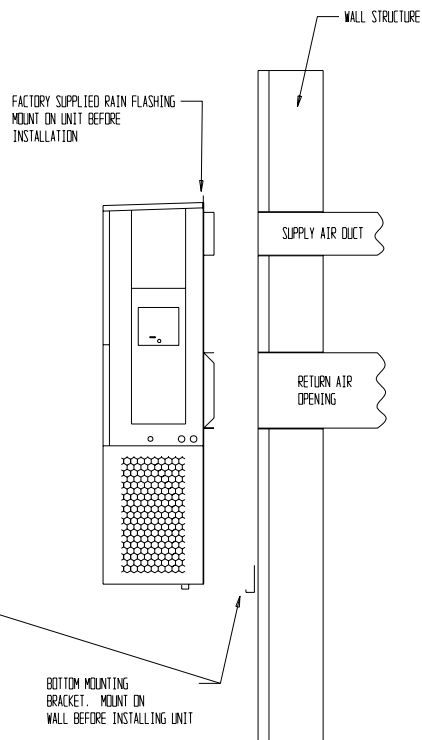

MIS-548

## FIGURE 6 WALL-MOUNTING INSTRUCTIONS

SEE UNIT DIMENSIONS, FIGURE 1,  
FOR ACTUAL DIMENSIONS

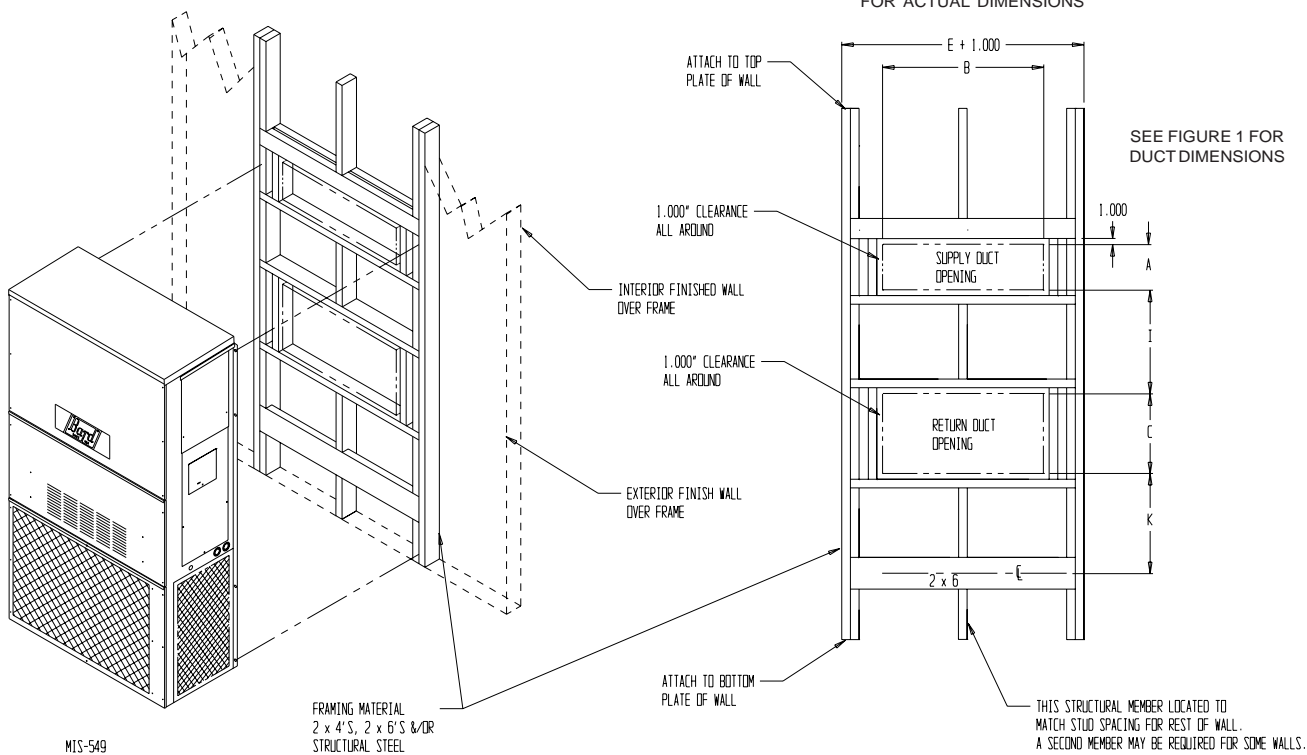

MIS-549

**FIGURE 7  
COMMON WALL-MOUNTING INSTALLATIONS**

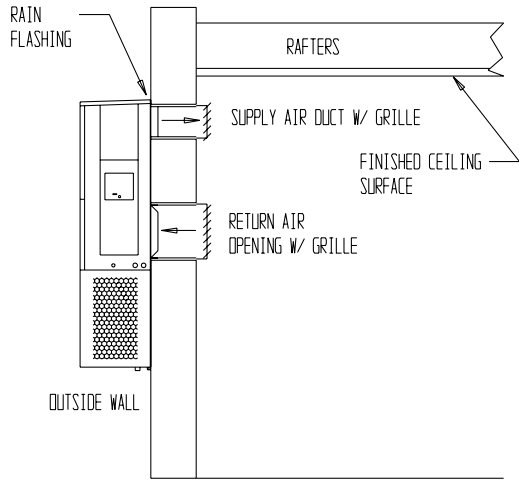

FREE AIR FLOW  
NO DUCT

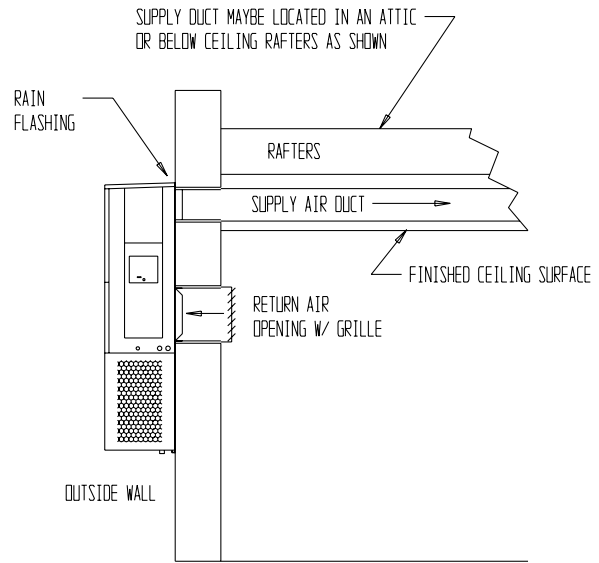

DUCTED SUPPLY  
RETURN AT UNIT

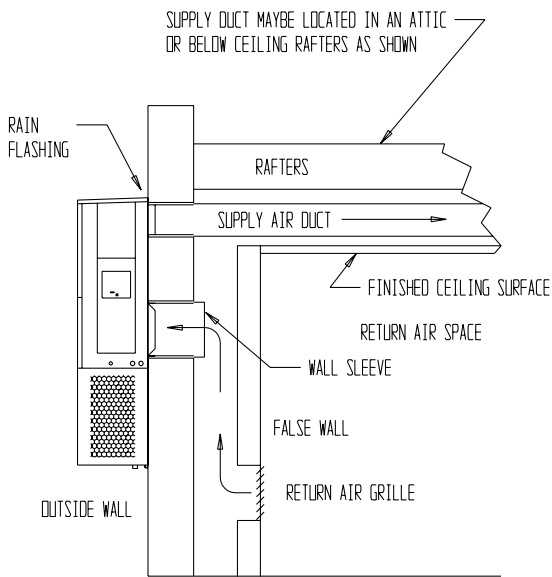

FALSE WALL INSTALLATION

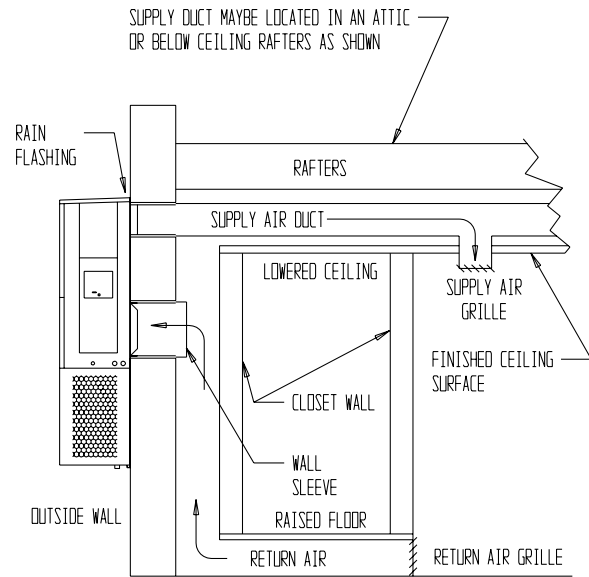

CLOSET INSTALLATION

MIS-550

## WIRING — MAIN POWER

Refer to the unit rating plate for wire sizing information and maximum fuse or “HACR” type circuit breaker size. Each outdoor unit is marked with a “Minimum Circuit Ampacity”. This means that the field wiring used must be sized to carry that amount of current. Depending on the installed KW of electric heat, there may be two field power circuits required. If this is the case, the unit serial plate will so indicate. All models are suitable only for connection with copper wire. Each unit and/or wiring diagram will be marked “Use Copper Conductors Only”. These instructions **must be** adhered to. Refer to the National Electrical Code (NEC) for complete current carrying capacity data on the various insulation grades of wiring material. All wiring must conform to NEC and all local codes.

The electrical data lists fuse and wire sizes (75°C copper) for all models, including the most commonly used heater sizes. Also shown are the number of field power circuits required for the various models with heaters.

The unit rating plate lists a “Maximum Time Delay Relay Fuse” or “HACR” type circuit breaker that is to be used with the equipment. The correct size must be used for proper circuit protection and also to assure that there will be no nuisance tripping due to the momentary high starting current of the compressor motor.

The disconnect access door on this unit may be locked to prevent unauthorized access to the disconnect. To convert for the locking capability, bend the tab located in the bottom left hand corner of the disconnect opening under the disconnect access panel straight out. This tab will now line up with the slot in the door. When shut, a padlock may be placed through the hole in the tab preventing entry.

See Start-up section for information on three phase scroll compressor start-ups.

## WIRING — LOW VOLTAGE WIRING

230/208V, 1 phase and 3 phase equipment dual primary voltage transformers. All equipment leaves the factory wired on 240V tap. For 208V operation, reconnect from 240V to 208V tap. The acceptable operating voltage range for the 240 and 208V taps are:

Tap	Range
240	253 - 216
208	220 - 197

**NOTE:** *The voltage should be measured at the field power connection point in the unit and while the unit is operating at full load (maximum amperage operating condition).*

If the #8403-058 thermostat is used, nine (9) wires should be run from the thermostat subbase to the 24V terminal board in the unit. If the #8403-060 thermostat/humidistat is used, ten (10) wires should be run from the thermostat subbase to the 24V terminal board. A nine (9) or ten (10) wire conductor (depending on thermostat used), 18 gauge copper color-coded thermostat cable is recommended. The connection points are shown in Figures 8 and 9.

## LOW VOLTAGE CONNECTIONS

These units use a grounded 24 volt AC low voltage circuit.

The “R” terminal is the *hot* terminal and the “C” terminal is *grounded*.

“G” terminal is the *fan input*.

“Y” terminal is the *compressor input*.

“B” terminal is the *reversing valve input*. The reversing valve must be energized for heating mode.

“R” terminal is *24 VAC hot*.

“C” terminal is *24 VAC grounded*.

“L” terminal is *compressor lockout output*. This terminal is activated on a high or low pressure trip by the electronic heat pump control. This is a 24 VAC output.

“W2” terminal is *second stage heat* (if equipped).

“O1” terminal is the *ventilation input*. This terminal energizes any factory installed ventilation option.

“E” terminal is the *emergency heat input*. This terminal energizes the emergency heat relay.

“W3” terminal is the *dehumidification input*. This terminal energizes compressor, blower and three-way valve.

**NOTE:** *For total and proper control using DDC, a total of 7 controlled outputs are required (6 if no ventilation system is installed). For proper system operation under Emergency Heat conditions where the compressor needs to be deactivated, the B-W2-E outputs need to be energized. Removing the Y (compressor) signal alone turns the compressor off, but does not activate the additional circuitry embedded in the heat pump for proper and complete operation.*

LOW VOLTAGE CONNECTIONS FOR DDC CONTROL	
Fan Only	Energize G
Cooling Mode	Energize Y, G
Heat Pump Heating	Energize Y, G, B
2nd Stg Heating w/Heat Pump (if employed)	Energize G, W2, Y, B
Ventilation	Energize G, O1
Emergency Heat	Energize B, W2, E, G
Dehumidification	Energize W3

**FIGURE 8**  
**WHXXDX – HOT GAS REHEAT DURING DEHUMIDIFICATION**  
**WITH CS2000A ENERGY MONITOR FULL TIME DEHUMIDIFICATION**

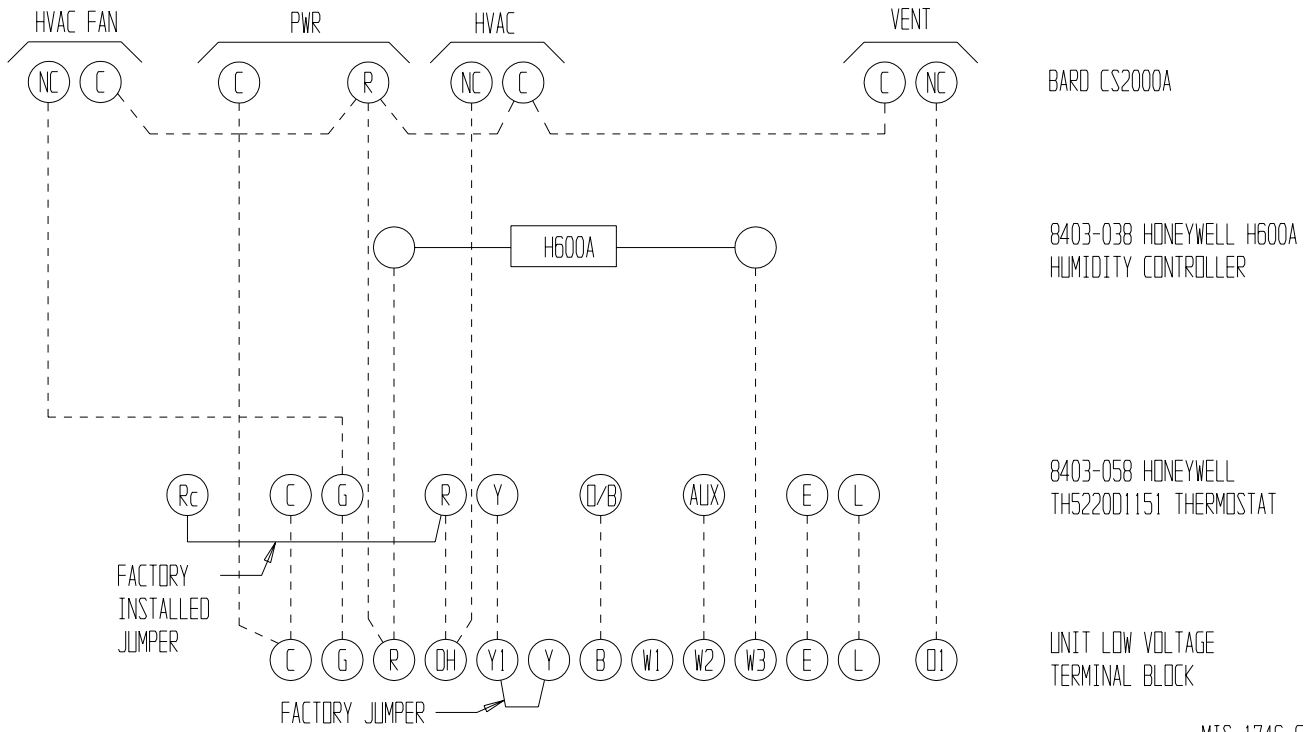

**FIGURE 9**  
**WHXXDX – HOT GAS REHEAT DURING DEHUMIDIFICATION**  
**WITH PROGRAMMABLE THERMOSTAT FULL TIME DEHUMIDIFICATION**

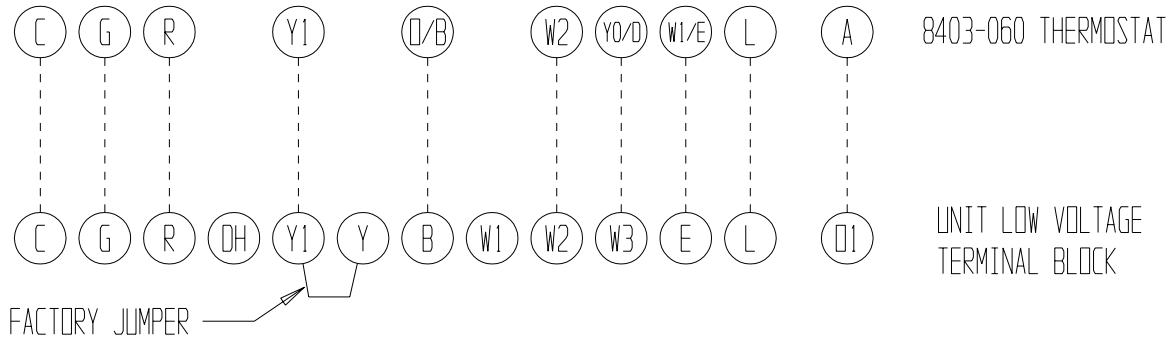

MIS-1745 A

THERMOSTAT MUST BE CONFIGURED TO "NO ECONOMIZER"  
 FOR THE HUMIDITY CONTROL OUTPUT TO BE ACTIVE

**IMPORTANT NOTE:**

*Only the thermostats as shown in Table 4 will work with this equipment. The thermostats **must** be matched, and the correct operation can be assured only by proper selection and application of these parts.*

**WHXXDX – HOT GAS REHEAT DURING DEHUMIDIFICATION**  
**WITH CS2000A ENERGY MONITOR AND 8403-060 THERMOSTAT**  
**WITH BUILT IN HUMIDISTAT FULL TIME DEHUMIDIFICATION**

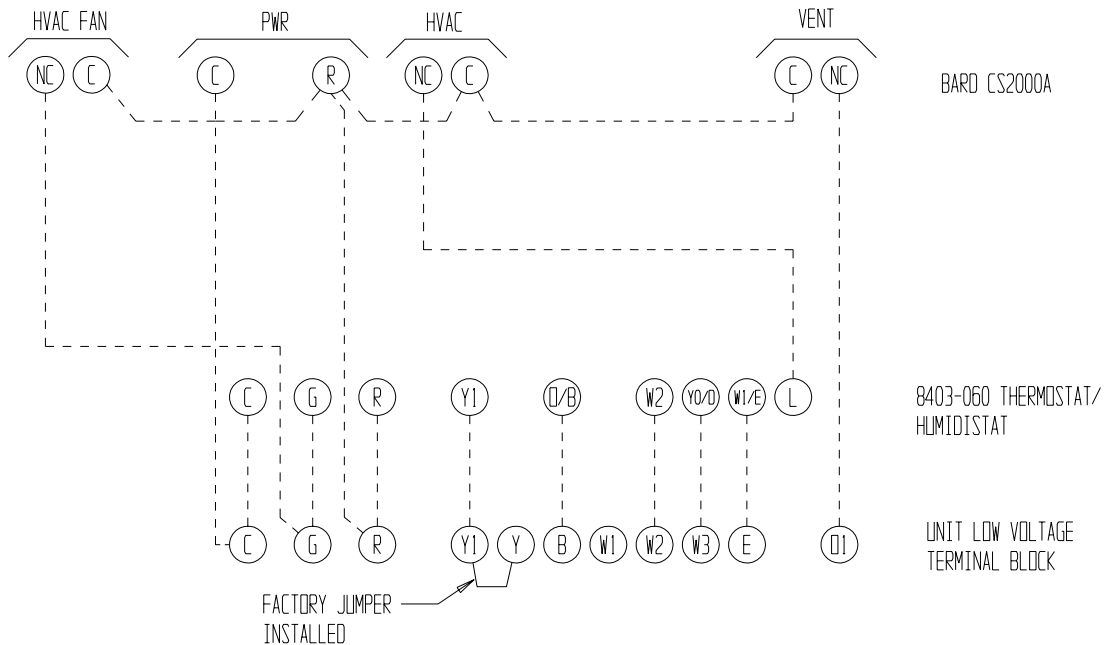

MIS-2315

**TABLE 3  
THERMOSTAT WIRE SIZE**

Transformer VA	FLA	Wire Gauge	Maximum Distance In Feet
55	2.3	20 gauge	45
		18 gauge	60
		16 gauge	100
		14 gauge	160
		12 gauge	250

**TABLE 4  
WALL THERMOSTATS**

Thermostat	Predominant Features
8403-058 (TH5220D1151)	2 stage Cool; 2 stage Heat Electronic Non-Programmable Auto or Manual changeover
8403-060 (1120-445)	3 stage Cool; 3 stage Heat Programmable/Non-Programmable Electronic HP or Conventional Auto or Manual changeover

Temperature and Humidity Controller #8403-060, along with the Outdoor Sensor option Part #8403-061, can be used to:

- Limit minimum outdoor temperature for cooling option.
- Limit minimum outdoor temperature for heat pump option.
- Inhibit electric heat operation for heat pumps above selected outdoor temperature.

Thus, not requiring the optional compressor cut-off thermostat or the electric heat cut-off thermostat option.

## IMPORTANT

Only the thermostats shown in this Manual have been tested with this equipment for proper operation. Proper unit operation with thermostats not listed in this Manual cannot be assured.

You assume responsibility for proper operation of the unit when using thermostats other than those listed above.



## IMPORTANT INSTALLER NOTE

For improved start-up performance, wash the indoor coil with a dishwashing detergent.

## CRANKCASE HEATERS

WH423D units are provided with compressor crankcase heat. WH484D and WH604D units are not provided with crankcase heat. These units utilize scroll compressors which do not require crankcase heat in this application.

The WH423D models have an insertion well-type heater located in the lower section of the compressor housing. This is a self-regulating type heater that draws only enough power to maintain the compressor at a safe temperature on these units.

Some form of crankcase heat is essential to prevent liquid refrigerant from migrating to the compressor, causing oil pump out on compressor start-up and possible valve failure due to compressing a liquid.

The decal in Figure 10 is affixed to all WH423D units detailing start-up procedure. This is very important. *Please read carefully.*

## HIGH PRESSURE SWITCH

The models are supplied with a remote reset high pressure switch. If tripped, this pressure switch may be reset by turning the thermostat off then back on again.

## THREE PHASE SCROLL COMPRESSOR START UP INFORMATION

Scroll compressors, like several other types of compressors, will only compress in one rotational direction. Direction of rotation is not an issue with single phase compressors since they will always start and run in the proper direction.

However, three phase compressors will rotate in either direction depending upon phasing of the power. Since there is a 50-50 chance of connecting power in such a way as to cause rotation in the reverse direction, verification of proper rotation must be made. All three phase scroll units incorporate a phase monitor to ensure proper field wiring. See the Phase Monitor later in this manual.

Verification of *proper rotation* must be made any time a compressor is change or rewired. If improper rotation is corrected at this time there will be no negative impact on the durability of the compressor. However, reverse operation for over one hour may have a negative impact on the bearing due to oil pump out.

**FIGURE 10  
START UP LABEL**

**IMPORTANT**

THESE PROCEDURES MUST BE FOLLOWED AT INITIAL START UP AND AT ANY TIME POWER HAS BEEN REMOVED FOR 12 HOURS OR LONGER.

TO PREVENT COMPRESSOR DAMAGE WHICH MAY RESULT FROM THE PRESENCE OF LIQUID REFRIGERANT IN THE COMPRESSOR CRANKCASE:

1. MAKE CERTAIN THE ROOM THERMOSTAT IS IN THE "OFF" POSITION. (THE COMPRESSOR IS NOT TO OPERATE.)
2. APPLY POWER BY CLOSING THE SYSTEM DISCONNECT SWITCH. THIS ENERGIZES THE COMPRESSOR HEATER WHICH EVAPORATES THE LIQUID REFRIGERANT IN THE CRANKCASE.
3. ALLOW 4 HOURS OR 60 MINUTES PER POUND OF REFRIGERANT IN THE SYSTEM AS NOTED ON THE UNIT RATING PLATE, WHICHEVER IS GREATER.
4. AFTER PROPER ELAPSED TIME THE THERMOSTAT MAY BE SET TO OPERATE THE COMPRESSOR.
5. EXCEPT AS REQUIRED FOR SAFETY WHILE SERVICING, DO NOT OPEN SYSTEM DISCONNECT SWITCH.

7961-411

*NOTE: If compressor is allowed to run in reverse rotation for several minutes, the compressor's internal protector will trip.*

All three phase ZR3 compressors are wired identical internally. As a result, once the correct phasing is determined for a specific system or installation, connecting properly phased power leads to the same Fusite terminal should maintain proper rotation direction.

Verification of proper rotation direction is made by observing that suction pressure drops and discharge pressure rises when the compressor is energized.

Reverse rotation also results in an elevated sound level over that with correct rotations, as well as, substantially reduced current draw compared to tabulated values.

The direction of rotation of the compressor may be changed by reversing any two line connections to the unit.

## PHASE MONITOR

All units with three phase scroll compressors are equipped with a 3 phase line monitor to prevent compressor damage due to phase reversal.

The phase monitor in this unit is equipped with two LEDs. If the Y signal is present at the phase monitor and phases are correct, the green LED will light. If phases are reversed, the red fault LED will be lit and compressor operation is inhibited.

If a fault condition occurs, reverse two of the supply leads to the unit. Do not reverse any of the unit factory wires as damage may occur.

## SERVICE HINTS

1. Caution owner/operator to maintain clean air filters at all times. Also, not to needlessly close off supply and return air registers. This reduces airflow through the system, which shortens equipment service life as well as increasing operating costs.
2. Switching to heating cycle at 75°F or higher outside temperature may cause a nuisance trip of the remote reset high pressure switch. Turn thermostat off, then on to reset the high pressure switch.
3. The heat pump wall thermostats perform multiple functions. Be sure that all function switches are correctly set for the desired operating mode before trying to diagnose any reported service problems.
4. Check all power fuses or circuit breakers to be sure they are the correct rating.
5. Periodic cleaning of the outdoor coil to permit full and unrestricted airflow circulation is essential.

## SEQUENCE OF OPERATION

### OCCUPIED MODE

**VENTILATION SEQUENCE** – The ERV and indoor blower will be continuously energized when the A1 terminal is energized.

**COOLING SEQUENCE** – On a call for cooling, the compressor of the unit is energized to provide cooling. A call for cooling cancels dehumidification mode. Cooling mode is only available when the timer is energized. See Figure 13.

Circuit R-Y makes at thermostat pulling in compressor contactor, starting the compressor and outdoor motor. The G (indoor motor) circuit is automatically completed on any call for cooling operation or can be energized by manual fan switch on subbase for constant air circulation. Refer to Figure 13.

**HEATING SEQUENCE** – On a call for heating, the compressor and reversing valve of the unit are energized to provide heat pump heating. If the room temperature falls below the 2nd stage heating set point backup electric heat is energized. Heat pump heating is only available when the timer is energized. If heating is energized any call for dehumidification is ignored. If dehumidification is already energized a call for 2nd stage heating is needed to cancel dehumidification mode.

A 24V solenoid coil on reversing valve controls heating cycle operation. A thermostat demand for heat completes R-W1 circuit, pulling in compressor contactor starting compressor and outdoor motor. R-G also make starting indoor blower motor.

**DEHUMIDIFICATION SEQUENCE** – On a call for dehumidification the compressor and three way valve of the unit are energized to provide dehumidification. Dehumidification mode will continue until the humidistat is satisfied. If the room temperature falls below 1st stage heating setpoint, electric heat will be energized by the room thermostat and cycle to maintain room temperature. If 2nd stage heating setpoint is reached, dehumidification is de-energized and heat pump heating is energized. A call for cooling cancels dehumidification mode. Refer to Figure 14.

### UNOCCUPIED MODE

Cooling, heating, emergency heat and ventilation are inhibited.

**DEHUMIDIFICATION SEQUENCE** – On a call for dehumidification the compressor and three way valve of the unit are energized to provide dehumidification. Dehumidification mode will continue until the humidistat is satisfied. If the room temperature falls below 65 degrees and dehumidification is energized, electric heat will be energized by the return air thermostat and cycle to maintain room temperature. See Figure 14.

### OTHER CONTROL SEQUENCE

Any time the indoor coil temperature falls below 32 degrees the compressor will be de-energized until the coil temperature rises above 57 degrees.

## PRESSURE SERVICE PORTS

High and low pressure service ports are installed on all units so that the system operating pressures can be observed. Pressure tables can be found later in the manual covering all models on both cooling and heating cycles. It is imperative to match the correct pressure curve to the unit by model number.

## DEFROST CYCLE

The defrost cycle is controlled by temperature and time on the solid state heat pump control. See Figure 11.

When the outdoor temperature is in the lower 40°F temperature range or colder, the outdoor coil temperature is 32°F or below. This coil temperature is sensed by the coil temperature sensor mounted near the bottom of the outdoor coil. Once coil temperature reaches 30°F or below, the coil temperature sensor sends a signal to the control logic of the heat pump control and the defrost timer will start.

After 60 minutes at 30°F or below, the heat pump control will place the system in the defrost mode.

During the defrost mode, the refrigerant cycle switches back to the cooling cycle, the outdoor motor stops, electric heaters are energized, and hot gas passing through the outdoor coil melts any accumulated frost. When the temperature rises to approximately 57°F, the coil temperature sensor will send a signal to the heat pump control which will return the system to heating operations automatically.

If some abnormal or temporary condition such as a high wind causes the heat pump to have a prolonged defrost cycle, the heat pump control will restore the system to heating operation automatically after 10 minutes.

The heat pump defrost control board has an option of 30, 60 or 90-minute setting. All models are shipped from the factory on the 60-minute pin. If special circumstances require a change to another time, remove the wire from the 60-minute terminal and reconnect to the desired terminal. The manufacturer's recommendation is for 60-minute defrost cycles. Refer to Figure 11.

There is a cycle speed up jumper on the control. This can be used to reduce the time between defrost cycle operation without waiting for time to elapse.

Use a small screwdriver or other metallic object, or another 1/4 inch QC, to short between the *SPEEDUP* terminals to accelerate the HPC timer and initiate defrost.

Be careful not to touch any other terminals with the instrument used to short the *SPEEDUP* terminals. It may take up to 10 seconds with the *SPEEDUP* terminals shorted for the speedup to be completed and the defrost cycle to start.

***As soon as the defrost cycle kicks in remove the shorting instrument from the SPEEDUP terminals.***

Otherwise the timing will remain accelerated and run through the 1-minute minimum defrost length sequence in a matter of seconds and will automatically terminate the defrost sequence.

There is an initiate defrost jumper (sen jump) on the control that can be used at any outdoor ambient during the heating cycle to simulate a 0° coil temperature. This can be used to check defrost operation of the unit without waiting for the outdoor ambient to fall into the defrost region.

By placing a jumper across the *SEN JMP* terminals (a 1/4 inch QC terminal works best) the defrost sensor mounted on the outdoor coil is shunted out and will activate the timing circuit. This permits the defrost cycle to be checked out in warmer weather conditions without the outdoor temperature having to fall into the defrost region.

In order to terminate the defrost test the *SEN JMP* jumper must be removed. If left in place too long the compressor could stop due to the high pressure control opening because of high pressure condition created by operating in the cooling mode with outdoor fan off. Pressure will rise fairly fast as there is likely no actual frost on the outdoor coil in this artificial test condition.

There is also a 5-minute compressor time delay function built into the HPC. This is to protect the compressor from short cycling conditions. In some instances it is helpful to the service technician to override or speed up this timing period, and shorting out the *SPEEDUP* terminals for a few seconds can do this.

**FIGURE 11  
DEFROST CONTROL BOARD**

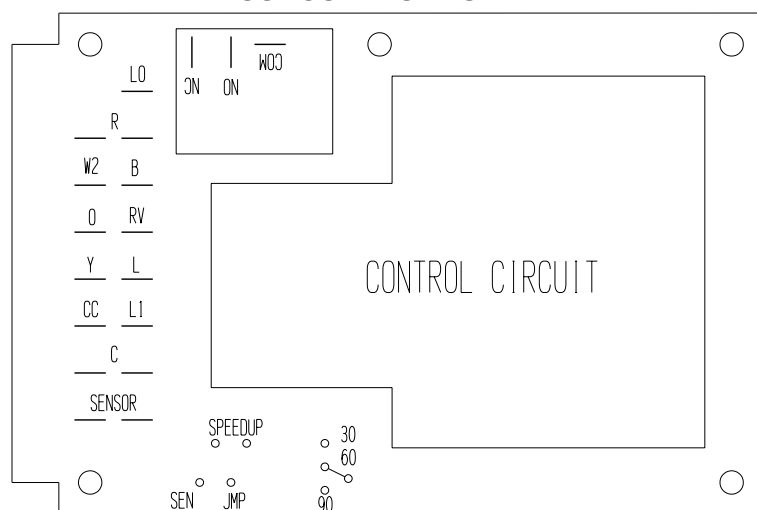

MIS-1174

# TROUBLESHOOTING

## SOLID STATE HEAT PUMP CONTROL TROUBLESHOOTING PROCEDURE

1. **NOTE:** A thorough understanding of the defrost cycle sequence is essential. Review that section earlier in this manual prior to troubleshooting the control. Turn on AC power supply to unit.
2. Turn thermostat blower switch to “fan on” – the indoor blower should start. (If it doesn’t, troubleshoot indoor unit and correct problem.)

3. Turn thermostat blower to “auto” position. Indoor blower should stop. **NOTE:** Many models have a 1-minute blower time delay on “off” command; wait for this to time-out.
4. Set system switch to “heat” or “cool”. Adjust thermostat to call for heat or cool. The indoor blower, compressor and outdoor fan should start.

*NOTE: If there was no power to 24 volt transformer, the compressor and outdoor fan motor will not start for 5 minutes. This is because of the compressor short cycle protection.*

**TABLE 5  
TROUBLESHOOTING**

Symptom	Possible Causes	What & How to Check / Repair
Compressor will not start (heating or cooling)	Check for 24V from R to C on the heat pump control	If 24V is not present at R, check wiring from board to transformer and check transformer input and output voltage. If transformer has no 24V output, determine cause and replace transformer.
	Check for 24V from Y to C on low voltage terminal strip	If 24V is not present, check thermostat and thermostat wiring, outdoor thermostat (if equipped) phase monitor (if equipped, used on some 3-phase models). If 24V is present continue to next step.
	Check for 24V from C to CC on heat pump control	If 24V is present, check and/or replace compressor contactor. If 24V is not present, jump the speed up terminal for 10 seconds. If compressor does not start check for 24V from C to L1 on the heat pump control.
	Compressor lock out	If 24V is not present at L1 of the heat pump control, check the high pressure switch and low pressure bypass relay (if equipped) and all associated wiring and terminals. The safety circuit is a closed circuit. If the high pressure switch or low pressure bypass relay are open, the control will lock out the compressor. Replace defective component. Cycle power off and on to reset lock out. Jump speed up terminals for 10 seconds to override 5-minute time delay.
	Defective heat pump control	If 24V is present from C to Y, and C to L1 on the heat pump control, the time delay has been overridden or expired and no 24V is present at CC, replace the heat pump control.
Fan outdoor motor does not run (cooling or heating except during defrost)	Heat pump control defective	Check across fan relay on heat pump control. (Com-NC) Replace heat pump control.
	Motor defective	Check for open or shorted motor winding. Replace motor.
	Motor capacitor defective	Check capacitor rating. Check for open or shorted capacitor. Replace capacitor.
Reversing valve does not energize (heating only)	Heat pump control defective	Check for 24V between RV-C and B-C. 1. Check control circuit wiring. 2. Replace heat pump control
	Reversing valve solenoid coil defective	Check for open or shorted coil. Replace solenoid coil.
Unit will not go into defrost (heating only)	Temperature sensor or heat pump control defective	Disconnect temperature sensor from board and jumper across "SPEEDUP" terminals and "SEN JMP" terminals. This should cause the unit to go through a defrost cycle within one minute. 1. If unit goes through defrost cycle, replace temperature sensor. 2. If unit does not go through defrost cycle, replace heat pump control.
Unit will not come out of defrost (heating only)	Temperature sensor or heat pump control defective.	Jumper across "SPEEDUP" terminal. This should cause the unit to come out of defrost within one minute. 1. If unit comes out of defrost cycle, replace temperature sensor. 2. If unit does not come out of defrost cycle, replace heat pump control.

## CHECKING TEMPERATURE SENSOR OUTSIDE UNIT CIRCUIT

1. Disconnect temperature sensor from board and from outdoor coil.
2. Use an ohmmeter and measure the resistance of the sensor. Also use ohmmeter to check for short or open.
3. Check resistance reading to chart of resistance. Use sensor ambient temperature. (Tolerance of part is  $\pm 10\%$ .)
4. If sensor resistance reads very low, then sensor is shorted and will not allow proper operation of the heat pump control.
5. If sensor is out of tolerance, shorted, open or reads very low ohms then it should be replaced.

### TEMPERATURE F VS. RESISTANCE R OF TEMPERATURE SENSOR

F	R	F	R	F	R
-25.0	196871	25.0	39898	75.0	10501
-24.0	190099	26.0	38757	76.0	10247
-23.0	183585	27.0	37652	77.0	10000
-22.0	177318	28.0	36583	78.0	9760
-21.0	171289	29.0	35548	79.0	9526
-20.0	165487	30.0	34545	80.0	9299
-19.0	159904	31.0	33574	81.0	9077
-18.0	154529	32.0	32634	82.0	8862
-17.0	149355	33.0	31723	83.0	8653
-16.0	144374	34.0	30840	84.0	8449
-15.0	139576	35.0	29986	85.0	8250
-14.0	134956	36.0	29157	86.0	8057
-13.0	130506	37.0	28355	87.0	7869
-12.0	126219	38.0	27577	88.0	7686
-11.0	122089	39.0	26823	89.0	7507
-10.0	118108	40.0	26092	90.0	7334
-9.0	114272	41.0	25383	91.0	7165
-8.0	110575	42.0	24696	92.0	7000
-7.0	107010	43.0	24030	93.0	6840
-6.0	103574	44.0	23384	94.0	6683
-5.0	100260	45.0	22758	95.0	6531
-4.0	97064	46.0	22150	96.0	6383
-3.0	93981	47.0	21561	97.0	6239
-2.0	91008	48.0	20989	98.0	6098
-1.0	88139	49.0	20435	99.0	5961
0.0	85371	50.0	19896	100.0	5827
1.0	82699	51.0	19374	101.0	5697
2.0	80121	52.0	18867	102.0	5570
3.0	77632	53.0	18375	103.0	5446
4.0	75230	54.0	17898	104.0	5326
5.0	72910	55.0	17434	105.0	5208
6.0	70670	56.0	16984	106.0	5094
7.0	68507	57.0	16547	107.0	4982
8.0	66418	58.0	16122	108.0	4873
9.0	64399	59.0	15710	109.0	4767
10.0	62449	60.0	15310	110.0	4663
11.0	60565	61.0	14921	111.0	4562
12.0	58745	62.0	14544	112.0	4464
13.0	56985	63.0	14177	113.0	4367
14.0	55284	64.0	13820	114.0	4274
15.0	53640	65.0	13474	115.0	4182
16.0	52051	66.0	13137	116.0	4093
17.0	50514	67.0	12810	117.0	4006
18.0	49028	68.0	12492	118.0	3921
19.0	47590	69.0	12183	119.0	3838
20.0	46200	70.0	11883	120.0	3757
21.0	44855	71.0	11591	121.0	3678
22.0	43554	72.0	11307	122.0	3601
23.0	42295	73.0	11031	123.0	3526
24.0	41077	74.0	10762	124.0	3452

## FAN BLADE SETTING DIMENSIONS

Shown in the drawing in Figure 12 are the correct fan blade setting dimensions for proper air delivery across the outdoor coil.

Any service work requiring removal or adjustment in the fan and/or motor area will require that the dimensions below be checked and blade adjusted in or out on the motor shaft accordingly.

**FIGURE 12  
FAN BLADE SETTING**

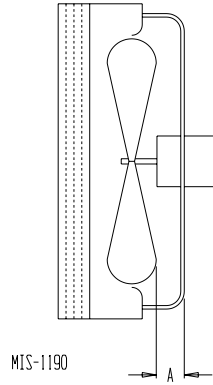

**TABLE 6  
FAN BLADE DIMENSIONS**

Model	Dimension A
WH423D	1.75
WH484D	
WH604D	

## REMOVAL OF FAN SHROUD

1. Disconnect all power to unit.
2. Remove the screws holding both grilles – one on each side of unit – and remove grilles.
3. Remove screws holding fan shroud to condenser and bottom – (9) screws.
4. Unwire condenser fan motor.
5. Slide complete motor, fan blade, and shroud assembly out the left side of the unit.
6. Service motor/fan as needed.
7. Reverse steps to reinstall.

**TABLE 9  
INDOOR BLOWER PERFORMANCE  
CFM @ 230V**

E.S.P. in H <sub>2</sub> O	WH423D, WH484D				WH604D			
	Low 230V		High 230V		Low 230V		High 230V	
	Dry Coil	Wet Coil	Dry Coil	Wet Coil	Dry Coil	Wet Coil	Dry Coil	Wet Coil
.0	1650	1600	1885	1800	1600	1450	2200	2000
.1	1550	1500	1770	1665	1525	1375	2100	1900
.2	1450	1400	1635	1540	---	---	2000	1800
.3	1350	1300	1500	1400	---	---	1875	1700
.4	1300	1175	1370	1285	---	---	1775	1600
.5	---	---	1250	1150	---	---	1650	1475

## REFRIGERANT CHARGE

The correct system R-22 charge is shown on the unit rating plate. Optimum unit performance will occur with a refrigerant charge resulting in a suction line temperature (6 inches from compressor) as shown in the Table 7.

**TABLE 7  
SUCTION LINE TEMPERATURES**

Model	Rated Airflow	95° F OD Temperature	82° F OD Temperature
WH423D	1400	52 -- 54	62 -- 64
WH484D	1550	53 -- 55	62 -- 64
WH604D	1700	52 -- 54	61 -- 63

The suction line temperatures in Table 7 are based upon 80°F dry bulb / 67 degrees F wet bulb (50 percent R.H.) temperature and rated airflow across the evaporator during cooling cycle.

**TABLE 8  
RECOMMENDED OPERATING RANGES**

Model	Rated CFM *	Rated ESP *	Recommended Airflow Range
WH423D	1400	.30	1600 - 1150
WH484D	1550	.20	1750 - 1285
WH604D	1700	.30	1950 - 1375

\* Rated CFM and ESP on high speed tap.

**TABLE 10  
MAXIMUM ESP OF OPERATION  
ELECTRIC HEAT ONLY**

Model Speed KW	WH423D		WH484D		WH604D	
	High Speed	Low Speed	High Speed	Low Speed	High Speed	Low Speed
-A00	.50	.50	.50	.50	.50	.40
-A05	.50	.50	.50	.50	.50	.25
-A10	.50	.45	.50	.45	.50	.25
-B00	.50	.50	.50	.50	.50	.40
-B09	.50	.45	.50	.45	.50	.30
-C00	.50	.50	.50	.50	.50	.40
-C09	.50	.40	.50	.40	.50	.35

Values shown are for units equipped with standard 1 inch throwaway filter on 1 inch washable filter. Derate ESP by .15 for 2 inch pleated filters.

**TABLE 11  
COOLING PRESSURE – (All temperatures °F)**

Model	Return Air Temperature	Pressure	75	80	85	90	95	100	105	110	115
WH423D	75 deg. DB 62 deg. WB	Low Side	72	73	75	76	78	79	80	82	84
		High Side	211	226	241	256	272	288	304	321	337
	80 deg. DB 67 deg. WB	Low Side	77	78	80	81	83	85	86	88	90
		High Side	216	232	247	263	279	295	312	329	346
	85 deg. DB 72 deg. WB	Low Side	80	81	83	84	86	88	89	91	93
		High Side	224	240	256	272	289	305	323	341	358
WH484D	75 deg. DB 62 deg. WB	Low Side	72	73	74	76	77	78	79	80	81
		High Side	215	229	245	261	278	295	313	332	351
	80 deg. DB 67 deg. WB	Low Side	77	78	79	81	82	83	84	86	87
		High Side	220	235	251	268	285	303	321	340	360
	85 deg. DB 72 deg. WB	Low Side	80	81	82	84	85	86	87	89	90
		High Side	228	243	260	277	295	314	332	352	373
WH604D	75 deg. DB 62 deg. WB	Low Side	71	72	74	75	76	77	79	79	80
		High Side	208	224	242	258	276	293	311	329	347
	80 deg. DB 67 deg. WB	Low Side	76	77	79	80	81	82	84	85	86
		High Side	213	230	248	265	283	301	319	337	356
	85 deg. DB 72 deg. WB	Low Side	79	80	82	83	84	85	87	88	89
		High Side	220	238	257	274	293	312	330	349	368

Low side pressure ± 2 psig  
High side pressure ± 5 psig

Tables are based upon rated CFM (airflow) across the evaporator coil. If there is any doubt as to correct operating charge being in the system, the charge should be removed, system evacuated and recharged to serial plate instruction.

**TABLE 12  
HEATING PRESSURES – (ALL TEMPERATURES °F)**

Model	Return Air Temperature	Pressure	0	5	10	15	20	25	30	35	40	45	50	55	60
WH423D	70 deg.	Low Side	19	21	24	27	30	34	38	42	47	51	56	61	67
		High Side	172	169	168	168	170	174	179	185	193	202	213	226	239
WH484D	70 deg.	Low Side	24	26	27	28	29	32	35	39	44	51	58	66	74
		High Side	171	173	176	178	180	184	190	197	205	214	225	237	250
WH604D	70 deg.	Low Side	24	24	25	27	29	32	36	41	46	52	59	66	74
		High Side	198	194	191	191	193	197	203	212	223	236	251	268	288

Low side pressure ± 2 psig  
High side pressure ± 5 psig

Tables are based upon rated CFM (airflow) across the evaporator coil. If there is any doubt as to correct operating charge being in the system, the charge should be removed, system evacuated and recharged to serial plate instruction.

**TABLE 13  
OPTIONAL ACCESSORIES**

Model	Description	WH423DA	WH423DB	WH423DC	WH484DA	WH484DB	WH484DC	WH604DA	WH604DB	WH604DC
EHWH42-A05	Heater Packages	X								
EHWH42-A10	Heater Packages	X								
EHWH42-C06	Heater Packages			X						
EHWH04-A05	Heater Packages				X			X		
EHWH04-A10	Heater Packages				X			X		
EHWH04-B09	Heater Packages		X			X			X	
EHWH04-C09	Heater Packages			X			X			X
BOP-5	Blank Off Plate	X	X	X	X	X	X	X	X	X
BFAD-5	Barometric Fresh Air Damper	X	X	X	X	X	X	X	X	X
MFAD-5	Motorized Fresh Air Damper	X	X	X	X	X	X	X	X	X
CRV-5	Classroom Ventilator with Exhaust	X	X	X	X	X	X	X	X	X
EIFM-4	Economizer with Exhaust	X	X	X	X	X	X	X	X	X
WERV-A5B	Energy Recovery Ventilator	X	X		X	X		X	X	
WERV-C5B	Energy Recovery Ventilator			X			X			X
CMH-3	Low Pressure Control (LPC)	X	X			X			X	
CMH-7	Low Ambient Control (LAC)	X	X	X	X	X	X	X	X	X
CMH-9	LAC + LPC	X	X	X	X	X	X	X	X	X
CMH-14	Outdoor Thermostat (ODT)	X	X	X	X	X	X	X	X	X
CMH-15	Start Kit (SK)	X								
WMCB-05	Circuit Breaker		X			X				
WMPD-01	Pull Disconnect Kit			X			X			X
WMCB-07B	Circuit Breaker								X	
WMCB-09A	Circuit Breaker							X		
WMCB-08B	Circuit Breaker	X			X					



**TABLE 14  
DEHUMIDIFICATION RELAY LOGIC BOARD**

	Inputs to Board										Outputs From Board									
	G	Y	B	W2	E1	A1	D	RAT	L	G1	BK	YO	WV	W	E	A2	TWV	L		
Cooling Mode	Unoccupied	X	X								X	X								
Cooling Mode	Occupied	X				X					X	X				X				
Cooling Mode	w/Dehum	X	X				X				X	X								
1st Stage Heating	Unoccupied	X	X							X	X	X								
1st Stage Heating	Occupied					X				X	X	X				X				
1st Stage Heating	w/Dehum	X	X				X			X	X	X		X			X			
2nd Stage Heating	Unoccupied	X	X							X	X	X		X						
2nd Stage Heating	Occupied	X	X			X				X	X	X		X		X				
2nd Stage Heating	w/Dehum	X	X				X			X	X	X		X						
Emergency Heat	Unoccupied			X	X					X	X		X	X	X					
Emergency Heat	Occupied			X	X	X				X	X		X	X	X	X				
Emergency Heat	w/Dehum			X	X		X			X	X				X		X			
Dehumidification	Unoccupied						X			X	X						X			
Dehumidification	Occupied						X	X		X	X		X				X	X		

**FIGURE 13  
BARD HEAT PUMP COOLING MODE  
CIRCUIT DIAGRAM**

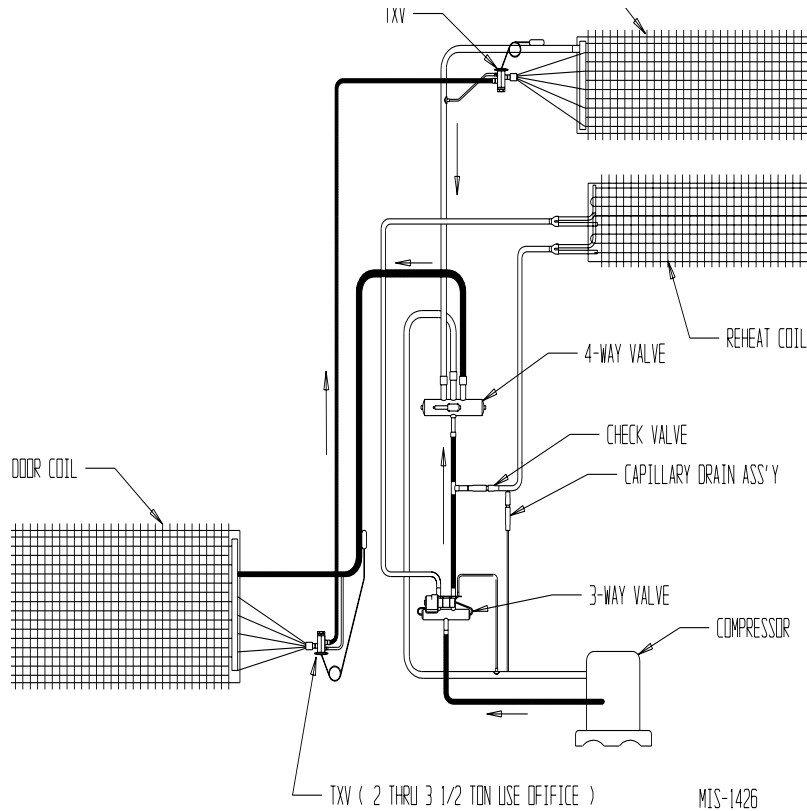

**FIGURE 14  
BARD HEAT PUMP DEHUMIDIFICATION MODE  
CIRCUIT DIAGRAM**

