



Bard Manufacturing Company, Inc.
 Bryan, Ohio 43506
Since 1914...Moving ahead, just as planned.

Manual: 2100-494
 Supersedes: **NEW**
 Tab: 20
 Date: 11-08-07

WF SERIES TROUBLESHOOTING PROCEDURES

WARNING

Before servicing this gas appliance, turn off all electric power supply and close all gas valves to the appliance. Failure to do so could result in fire, personal injury, or death.

TURN ON AC POWER SUPPLY — TURN UP THERMOSTAT

SYMPTOM	POSSIBLE CAUSES	HOW TO CHECK AND/OR CORRECT
Induced draft blower does not operate.	Thermostat or thermostat wiring defective.	Remove thermostat wires from the furnace control board. Jumper terminals "R" and "W" on furnace control board. If inducer blower starts: A. Check thermostat wiring B. Change thermostat
	No main power supply, 24 volt power supply, or blown 3A fuse on furnace control.	Remove low voltage wires from transformer. Check for 24 volts AC coming out of transformer. If there is no voltage present: A. Check for appropriate AC voltage at terminals "L1" and "L2". If there is no voltage, check power supply or breaker. B. If there is line voltage present at terminals "L1" and "L2", but there is not 24 volts present at the transformer leads, the transformer must be replaced. C. Replace 3A fuse on furnace control.
	Furnace control board defective.	If 24 volts is not present at Pin 1 and Pin 2 at the plug on the board and line voltage is present at "L1" and "L2" and there is no power at "L2" and "D1", the board must be replaced.
Direct spark igniter does not spark.	Pressure switch is defective. Spark igniter assembly is defective. Ignition cable is defective. Furnace control is defective. Debris shorting out spark igniter.	With thermostat calling for heat, jumper the two pressure terminals. If igniter starts sparking, check for: A. Blockage in vent terminal B. Excessive dirt, lint, soot or scale on induced draft blower wheel. C. Check for poor connection, leaks, or blockage in the tubing connecting the pressure switch to the inducer. D. Pressure switch is defective.
Igniter sparks but there is no ignition.	No gas supply. Gas orifice obstructions. Low gas supply pressure. Defective ignition control.	Check for obstructions in main gas orifices Make sure all gas cocks are open and gas valve is in the "ON" position. Make sure that the minimum gas supply pressure, stated on the rating plate, is available to the gas valve.

Troubleshooting Procedures continued on Page 2.

NOTE: Before replacing any component of this unit, verify that all wiring is correct with the wiring diagram.

Troubleshooting Procedures

(continued from Page 1)

SYMPTOM	POSSIBLE CAUSES	HOW TO CHECK AND/OR CORRECT
Main burner lights but the comfort air blower does not run.	Defective furnace control board, blower motor or capacitor.	Once burner lights, wait approximately 30 seconds and check for supply voltage AC between "L2" and "HEAT" terminals on furnace control board. If there is no voltage present, replace board. If voltage is present, check capacitor. If capacitor is good, replace blower motor.
Main burner cycles on and off or stays off and the induced draft blower and comfort air blower do not shut off.	Limit switches opening due to high outlet air temperature or defective control.	Jumper terminals on both sides of each limit switch. If this corrects cycling problem check: A. Limit setting on control should be at setting specified on the furnace rating plate. B. Clogged or dirty filters. C. Static pressure on supply side not to exceed that specified on the rating plate. D. Inadequate return air sizing. E. Defective limit control.
	Flame roll-out switch is open due to flame rolling out of combustion area caused by inadequate combustion air through the heat exchanger. The flame roll-out switch is located on top of the burner box assembly.	The flame roll-out switch is a manual reset control. Check to make sure the switch has been reset. Check for blockage in the vent terminal and/or the induced draft blower. If blockage is present, remove obstruction. Also check for blockage in the heat exchanger flue passageways. Remove any blockage.
	Pressure switch defective or malfunctioning.	Jumper out terminals on the pressure switch, if this corrects cycling problem check: A. Blockage in vent terminal. B. Excessive dirt, lint, soot or scale on induced draft blower. C. Defective pressure switch.
Comfort air blower does not stop.	Defective furnace control board.	If comfort air blower continues to run for more than 2 - 3 minutes after the call for heat has been satisfied, the furnace control board must be replaced.

DIAGNOSTIC INDICATOR

A red LED is provided to indicate system faults as follows:

- Steady ON - Control okay in standby, call for heat, cool or fan modes
- Steady OFF - Internal control fault or no power. Also check 3A fuse on control.
- 1 flash - Lockout due to failed ignition or flame dropouts
- 2 flashes - Pressure switch open with inducer on
- 3 flashes - Pressure switch is closed with inducer off
- 4 flashes - Limit switch is open
- 5 flashes - Flame detected with gas valve closed

The flash rate is 0.25 seconds on, 0.25 seconds off with 2.0 seconds pause between flash codes.

WF SERIES

UNDERSTANDING THE PRESSURE CONTROL

All WF models are equipped with a pressure sensing device. This device performs the two important functions shown below:

- Prevents main burner operation in the event of inadequate combustion air or a failed combustion air blower.
- Prevents main burner operation in the event the vent terminal should become obstructed.

This pressure device is commonly referred to as a pressure switch. The switch consists of normally open contacts which close when a specified amount of negative pressure (vacuum) is applied to the mechanical side of the device. The switch will remain closed as long as the required amount of negative pressure is present. If that negative pressure or vacuum reduces below the required amount, the switch contacts will open, thus shutting down the unit. The source of this negative pressure is created within the combustion air blower housing, and is transferred from the blower housing to the pressure switch through a 3/16" diameter silicone tube. If any unusual restriction is applied any point downstream of the combustion air blower, the negative pressure or vacuum within the blower housing will decrease, opening the switch contacts and shutting down the unit.

All WF series use the same pressure switch. The pressure switch contacts close at negative .62" W.C. and open at negative .52" W.C. for units installed from 0 – 6,000 feet elevation above sea level. If unit is installed above 6,001 feet the unit must be converted using a high altitude pressure switch, Bard kit number, 8620-189. The pressure switch included with this kit is designed for the contacts to close at a negative .52" W.C. and open at .42" W.C.

PRESSURE MEASUREMENT WITHIN THE SYSTEM

To measure the pressure within the system, a pressure gauge with a range of 0 to 1 inch water column in .02 inch W.C. increments is required.

This gauge is to be connected to the silicone tubing between the pressure switch and the combustion air blower. Refer to Figure 1 on Page 4.

A small plastic or copper tee and a 3/16" diameter piece of hose is used to connect the gauge between the combustion air blower and the pressure switch.

With the gauge in place, start the unit and monitor the pressure within the system. The ignition device will be activated once the pressure exceeds the switch contact close points specified above. As the furnace warms up, the pressure will drop about .2" W.C.

The pressure within the system should not drop to or below the switch contacts open point shown above. If the switch contacts open above or below the specified set point $\pm .05$ " W.C., the switch must be replaced.

If the pressure within the system drops to the switch open set points, the following items should be checked:

1. Any obstruction in the vent terminal
2. Any excessive lint, dirt or scale on the combustion air blower wheel
3. Any obstructions or moisture inside the 3/16" silicone tubing

FIGURE 1

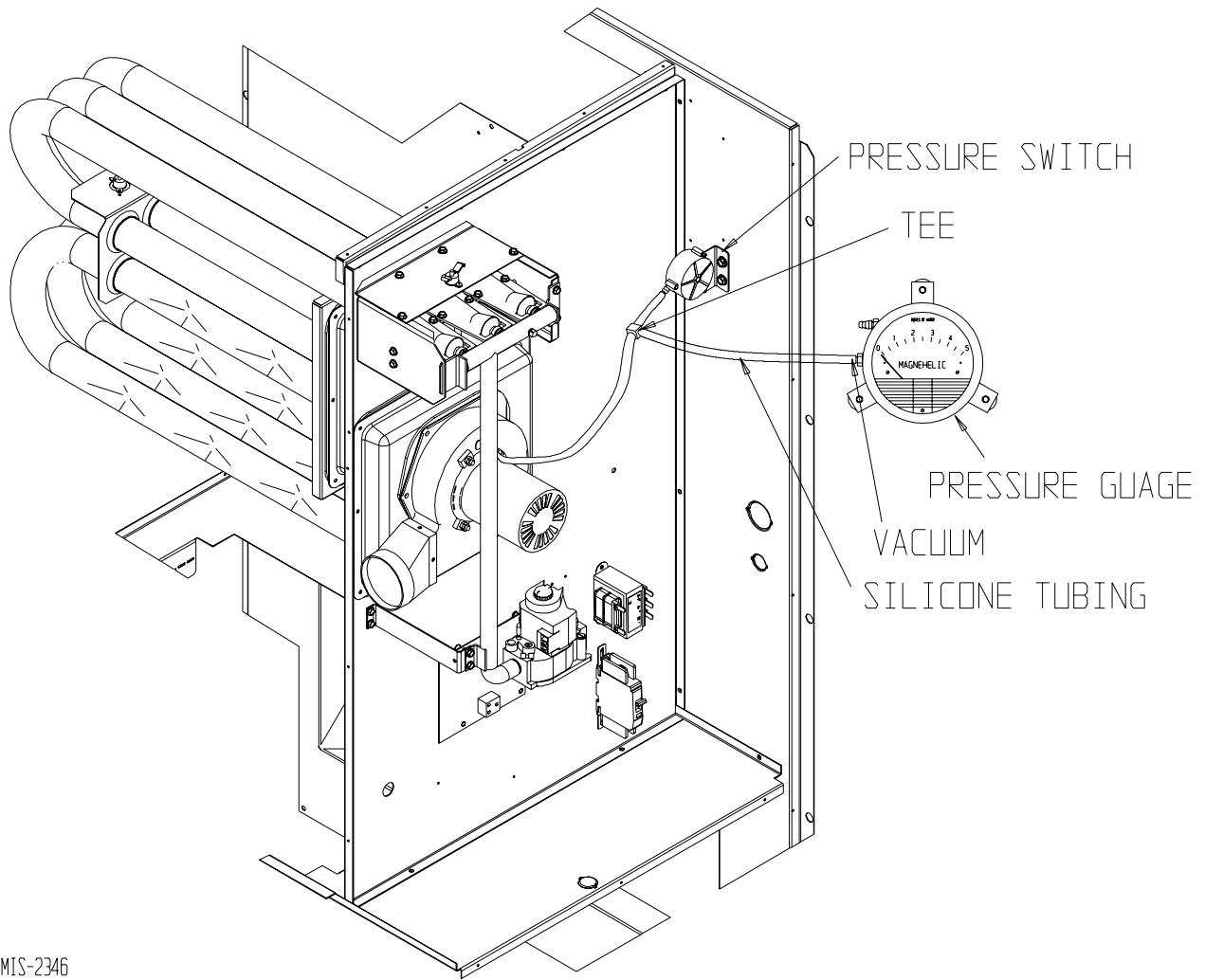

MIS-2346