

---

# INSTALLATION INSTRUCTIONS

---

## ENERGY RECOVERY VENTILATOR WITH EXHAUST

**MODELS:  
WFERV**



CLIMATE CONTROL SOLUTIONS

Bard Manufacturing Company, Inc.  
Bryan, Ohio 43506

*Since 1914...Moving ahead, just as planned.*

Manual: 2100-495  
Supersedes: **NEW**  
File: Volume III, Tab 19  
Date: 11-08-07

# CONTENTS

---

Model Nomenclature Legend .....	3	Control Wiring .....	15
Electrical Specifications .....	3	Control Requirements .....	15
General Description .....	3	Recommended Control Sequences .....	15
General Information .....	3	Ventilation Airflow .....	15
Unpacking .....	3	Energy Recovery Ventilator Maintenance .....	16
Performance and Application Data - WFERV .....	4	Maintenance Procedures .....	16
Basic Installation (Field Installation) .....	5 & 6	Quarterly & Annual Maintenance .....	17
Basic Installation (Factory Installed Versions) .....	15	Wiring Diagram .....	21

## Figures

Figure 1 Intake Hood Assembly .....	6
Figure 2 Remove Vent Option Door .....	7
Figure 3 Filter & Exhaust Plate Location .....	8
Figure 4 Installation of Exhaust Blower Assembly ...	9
Figure 5 Installation of WFERV .....	10
Figure 6 WFERV Assembly .....	11
Figure 7 Wiring - 230 Volt .....	12
Figure 8 Installation of Fresh Air Intake Hood Assembly .....	13
Figure 9 Operation of Unit with WFERV .....	14
Figure 10 Thermostat Wiring .....	18
Figure 11 Terminal Block Location Diagram .....	19
Figure 12 Hub Assembly with Ball Bearings .....	20

## Tables

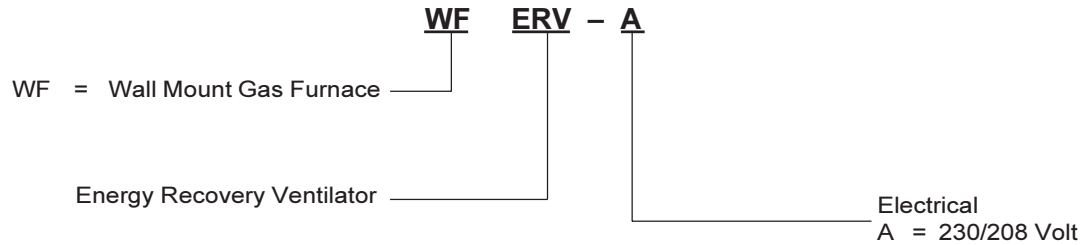
Table 1 Ventilation Air (CFM) .....	16
-------------------------------------	----

**COPYRIGHT SEPTEMBER 2007  
BARD MANUFACTURING COMPANY, INC.  
BRYAN, OHIO USA 43506**

---

Manufactured under the following U.S. patent numbers:  
5,485,878; 5,0023,116; 4,924,934;  
4,875,520; 4,825,936

## MODEL NOMENCLATURE LEGEND



## ELECTRICAL SPECIFICATIONS

Model	Voltage	Amps	Control Voltage
WFERV	230/208	2.1	24V

**NOTE:** *Never set intake blower at a lower speed than the exhaust blower, as it will create a negative pressure in the room.*

*During operation below 5 degrees F outdoor temperature, freezing of moisture in the heat transfer wheel can occur. Consult the factory if this possibility exists.*

## GENERAL DESCRIPTION

The Energy Recovery Ventilator was designed to provide energy efficient, cost effective ventilation to meet I.A.Q. (Indoor Air Quality) requirements while still maintaining good indoor comfort and humidity control for a variety of applications such as schools, classrooms, lounges, conference rooms, beauty salons and others. It provides a constant supply of fresh air for control of airborne pollutants including CO<sub>2</sub>, smoke, radon, formaldehyde, excess moisture, virus and bacteria.

The ventilator incorporates patented rotary heat exchanger technology to remove both heat and moisture.

It is designed as a single package, which can be easily factory or field installed for new installations or retrofit to Bard WF wall mounted units. The package consists of a unique rotary Energy Recovery Cassette that can be easily removed for cleaning or maintenance. The cassette has a 21-inch diameter heat transfer wheel for efficient heat transfer. The heat transfer wheel uses a permanently bonded dry desiccant coating for total heat recovery.

Ventilation is accomplished with two (2) blower/motor assemblies each consisting of a drive motor and dual blowers for maximum ventilation at low sound levels. On non-independent motor control models, the air is exhausted at the same rate that fresh air is brought into the structure, thus not impacting building pressure. On independent motor control models, the air can be exhausted at a different rate than the intake or fresh air. Never operate the fresh air at a lower speed than the exhaust air. Operating the fresh air at a higher speed than the exhaust air will help maintain a slight positive pressure in the building. The rotating energy wheel provides the heat transfer effectively during both summer and winter conditions. Provides required ventilation to meet the requirements of ASHRAE 62.1-2004 standard.

## GENERAL INFORMATION

The ventilator should only be installed by a trained heating and air conditioning technician. These instructions serve as a guide to the technician installing the ventilator package. They are not intended as a step-by-step procedure with which the mechanically-inclined owner can install the package.

The ventilator housing is shipped in one carton, which contains the following:

1. Energy Recovery Ventilator
2. Service Door
3. Rain Hood and Mist Eliminator
4. Installation Instructions

## UNPACKING

Upon receipt of the equipment, be sure to compare the model number found on the shipping label with the accessory identification information on the ordering and shipping document to verify that the correct accessory has been shipped.

Inspect the carton housing of each ventilator as it is received, and before signing the freight bill, verify that all items have been received and that there is no visible damage. Note any shortages or damage on all copies of the freight bill. The receiving party must contact the last carrier immediately, preferably in writing, requesting inspection by the carrier's agent. Concealed damage not discovered until after loading must be reported to the carrier within 15 days of its receipt.

## APPLICATION DATA — WFERV

### SUMMER COOLING PERFORMANCE (INDOOR DESIGN CONDITIONS 75°DB/63°WB)

Ambient O.D.		VENTILATION RATE — 450 CFM High Speed (Black) 72% EFFICIENCY						VENTILATION RATE — 370 CFM Medium Speed (Blue) 73% EFFICIENCY						VENTILATION RATE — 280 CFM Low Speed (Red) 74% EFFICIENCY					
		DB/ WB	F	VLT	VLS	VLL	HRT	HRS	HRL	VLT	VLS	VLL	HRT	HRS	HRL	VLT	VLS	VLL	HRT
105	75	17400	12800	4600	12500	9200	3300	15200	11200	4000	11100	8200	2900	12400	9100	3300	9200	6700	2500
	70	12800	12800	0	9200	9200	0	11200	11200	0	8200	8200	0	9100	9100	0	6700	6700	0
	65	12800	12800	0	9200	9200	0	11200	11200	0	8200	8200	0	9100	9100	0	6700	6700	0
100	80	26600	10700	15900	19100	7700	11400	23400	9400	14000	17100	6900	10200	18900	7600	11300	14000	5600	8400
	75	17500	10700	6800	12600	7700	4900	15400	9400	6000	11200	6900	4300	12400	7600	4800	9200	5600	3600
	70	10700	10700	0	7700	7700	0	9400	9400	0	6900	6900	0	7600	7600	0	5600	5600	0
	65	10700	10700	0	7700	7700	0	9400	9400	0	6900	6900	0	7600	7600	0	5600	5600	0
	60	10700	10700	0	7700	7700	0	9400	9400	0	6900	6900	0	7600	7600	0	5600	5600	0
95	80	26800	8600	18200	19300	6200	13100	23400	7500	15900	17100	5500	11600	19000	6100	12900	14000	4500	9500
	75	17700	8600	9100	12700	6200	6500	15500	7500	8000	11200	5500	5700	12500	6100	6400	9200	4500	4700
	70	9600	8600	1000	6900	6200	700	8400	7500	900	6100	5500	600	6800	6100	700	5000	4500	500
	65	8600	8600	0	6200	6200	0	7500	7500	0	5500	5500	0	6100	6100	0	4500	4500	0
	60	8600	8600	0	6200	6200	0	7500	7500	0	5500	5500	0	6100	6100	0	4500	4500	0
90	80	26800	6400	20400	18300	4600	14700	23500	5600	17900	17200	4100	13100	19100	4600	14500	14100	3400	10700
	75	17700	6400	11300	12700	4600	8100	15600	5600	10000	11400	4100	7300	12700	4600	8100	9400	3400	6000
	70	9600	6400	3200	6900	4600	2300	8400	5600	2800	6100	4100	2000	6900	4600	2300	5100	3400	1700
	65	6400	6400	0	4600	4600	0	5600	5600	0	4100	4100	0	4600	4600	0	3400	3400	0
	60	6400	6400	0	4600	4600	0	5600	5600	0	4100	4100	0	4600	4600	0	3400	3400	0
85	80	27100	4300	22800	19500	3100	16400	23800	3800	20000	17400	2800	14600	19200	3000	16200	14200	2200	12000
	75	17900	4300	13600	12900	3100	9800	15800	3800	12000	11500	2800	8700	12700	3000	9700	9400	2200	7200
	70	9700	4300	5400	6900	3100	3800	8600	3800	4800	6300	2800	3500	6900	3000	3900	5100	2200	2900
	65	4300	4300	0	3100	3100	0	3800	3800	0	2800	2800	0	3000	3000	0	2200	2200	0
	60	4300	4300	0	3100	3100	0	3800	3800	0	2800	2800	0	3000	3000	0	2200	2200	0
80	75	1800	2100	15900	13000	1500	11500	15800	1900	13900	11500	1400	10100	12800	1500	11300	9500	1100	8400
	70	9800	2100	7700	7000	1500	5500	8700	1900	6800	6300	1400	4900	7000	1500	5500	5200	1100	4100
	65	2500	2100	400	1800	1500	3000	2300	1900	400	1700	1400	300	1800	1500	300	1300	1100	200
	60	2100	2100	0	1500	1500	0	1900	1900	0	1400	1400	0	1500	1500	0	1100	1100	0
75	70	10000	0	10000	7200	0	7200	8800	0	8800	6400	0	6400	7100	0	7100	5200	0	5200
	65	2600	0	2600	1900	0	1900	2400	0	2400	1750	0	1750	1900	0	1900	1400	0	1400

### WINTER HEATING PERFORMANCE (INDOOR DESIGN CONDITIONS 70° F DB)

Ambient O.D.	VENTILATION RATE					
	450 CFM 76% EFF.		370 CFM 78% EFF.		280 CFM 80% EFF.	
	DB°F	WVL	WHR	WVL	WHR	WVL
65	4900	3720	3400	2650	2400	1920
60	6400	4860	4900	3820	3900	3120
55	7900	6000	6400	4990	5400	4320
50	9400	7150	7900	6160	6900	5520
45	11800	8970	9900	7720	8500	6800
40	14100	10710	11800	9200	10300	8240
35	17300	13150	13500	10530	11200	8960
30	18900	14360	15700	12250	13700	10960
25	21200	16110	17700	13800	15400	12320
20	23600	17940	19700	15370	17100	13680
15	25900	19680	21700	16930	18800	15040


**LEGEND:**

- VLT = Ventilation Load – Total
- VLS = Ventilation Load – Sensible
- VLL = Ventilation Load – Latent
- HRT = Heat Recover – Total
- HRS = Heat Recovery – Sensible
- HRL = Heat Recovery – Latent
- WVL = Winter Ventilation Load
- WHR = Winter Heat Recovery

**NOTE:** Sensible performance only is shown for winter application

## BASIC INSTALLATION (Field Installation)

1. Unpack the ventilator assembly, which includes the integral ventilator with attached electrical harness and miscellaneous hardware.

	<h1>WARNING</h1>
<p>Open breaker switch before installing this accessory to prevent injury or death due to electrical shock or contact with moving parts. Turn thermostat to OFF.</p>	

Model	For Use With Following Units	Electrical
WFERV	WF050-125	230/208-1 or 3 phase

2. Remove intake hood assembly from back of ventilator. (See Figure 1.)
3. Remove the existing exterior vent option door on the unit. (See Figure 2.)
4. Remove and save existing unit air filter. Remove and discard the rear exhaust cover plate and remove center screw from condenser grille. (See Figure 3.)
5. Install exhaust blower assembly in rear exhaust opening and secure with four (4) screws. Position 4 pin connector so it is accessible. (See Figure 4.)
6. Install ventilator into the unit. (See Figure 5.)

*IMPORTANT NOTE: Position front lip of ventilator over front grille and on top of condenser partition. (See Figure 5.) This is important to insure proper drainage of any water entering damper assembly.*

7. Remove cassette and plug in exhaust blower. Replace cassette. (See Figure 6.)

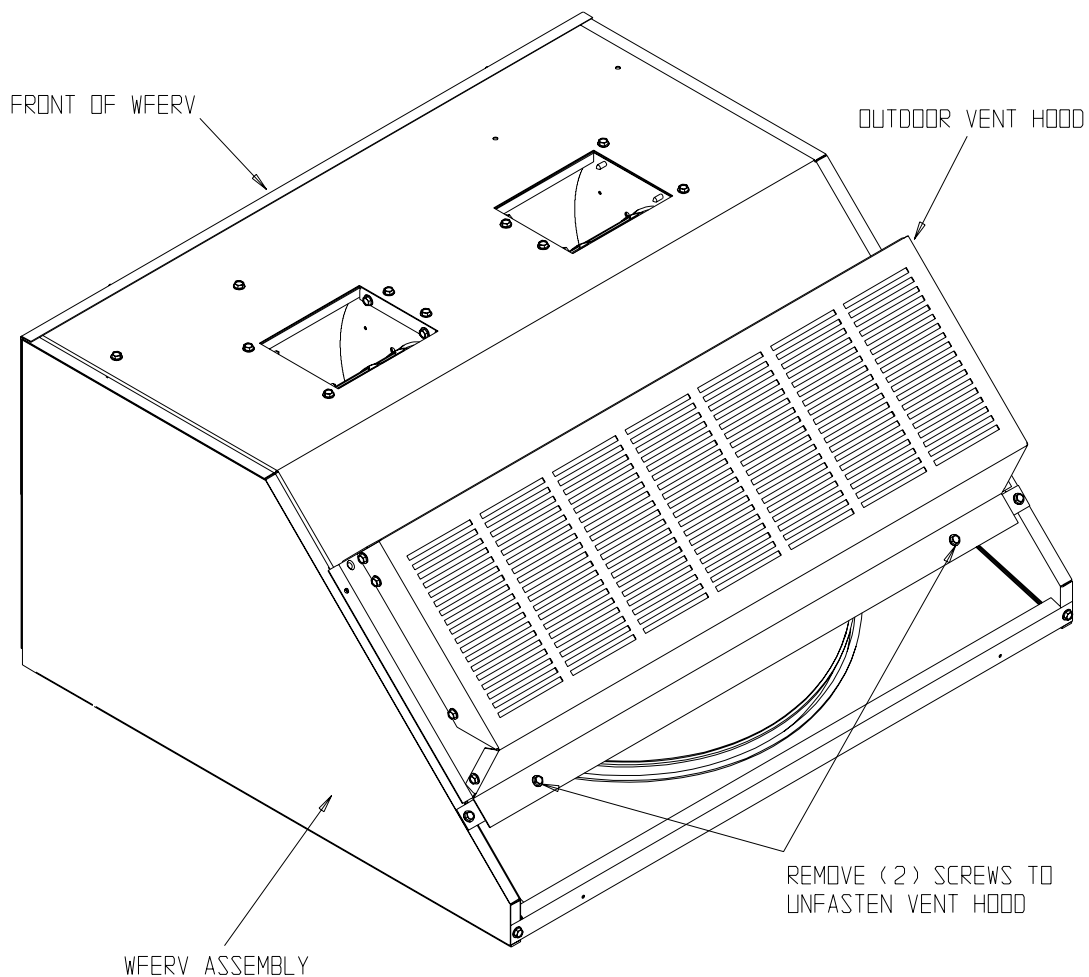
8. Open control panel to gain access to unit low voltage terminal block. (Insure all power is OFF prior to opening the control panel.)
9. Remove female plug of low voltage wiring harness from the heat recovery assembly and snap into filter rack. Route electrical harness leads through the 7/8" bushing into the low voltage box. (See Figure 5.)
10. Connect leads C (black), W (blue), and G (orange) with fork terminal to corresponding points on terminal strip. (See Figure 7 for 230V units.)

*NOTE: These 24 volt control wires control the starting and stopping of the Energy Recovery Ventilator and can be independently controlled by an energy management control or timer. See separate section on Control Wiring for suggested control schemes.*

11. Remove female plug of high voltage wiring harness from the heat recover assembly and snap into filter rack. Wire to terminal block. (See Figure 7 for 230V units.)
12. Plug male plug from female at filter rack. (See Figure 5.)
13. Close control panel cover.
14. Replace filter and one (1) screw in condenser grille. (See Figure 3)
15. Ventilator checkout
  - A. Resupply power to unit.
  - B. Energize the evaporator blower by switching thermostat to the manual fan position with Heat/Cool in OFF position.
  - C. Ventilator heat transfer wheels should rotate slowly (49 RPM). Intake and exhaust blowers should run. (See Figure 9.)
  - D. De-energize the evaporator blower. Energy Recovery wheels, and fresh air and exhaust air blowers should stop.
  - E. This completes ventilator checkout.

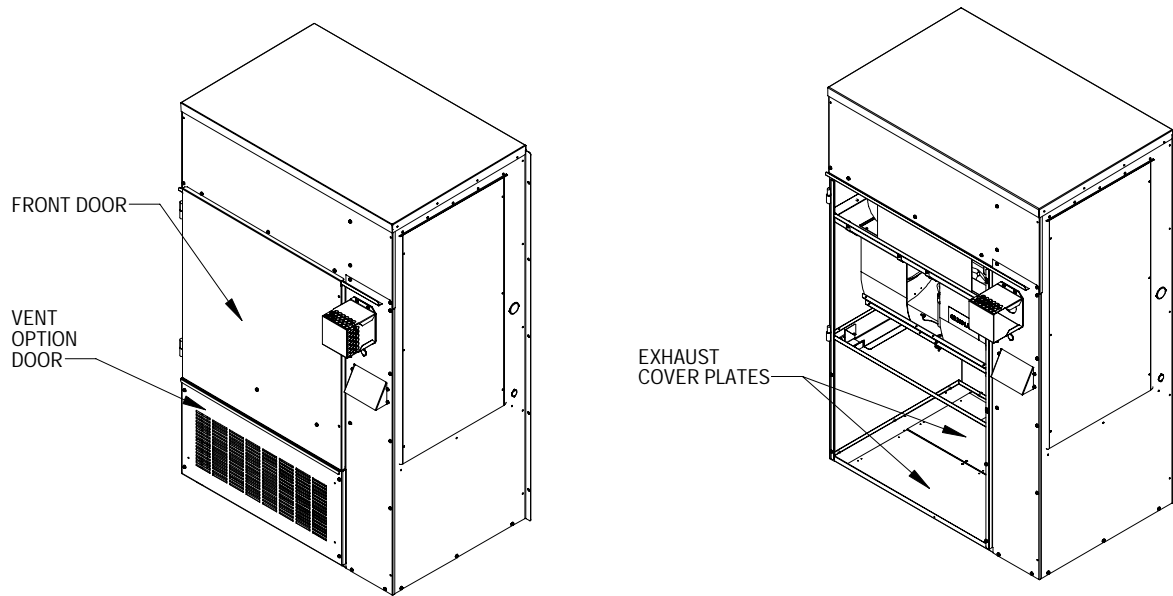
16. Disconnect the wires connected in Step 10 if other control options are to be used.
17. Replace the lower service access panel with the new panel provided. Attach air intake hood with screws provided. (See Figure 9.) Be sure to insert the top flange of the air intake hood into and through the slot in the service door and between the door and insulation to prevent bowing of the door.
18. Close front door.
19. Apply Certification label, included with Installation Instructions, next to unit Serial Plate.
19. Ventilator is now ready for operation.

**FIGURE 1  
INTAKE HOOD ASSEMBLY**



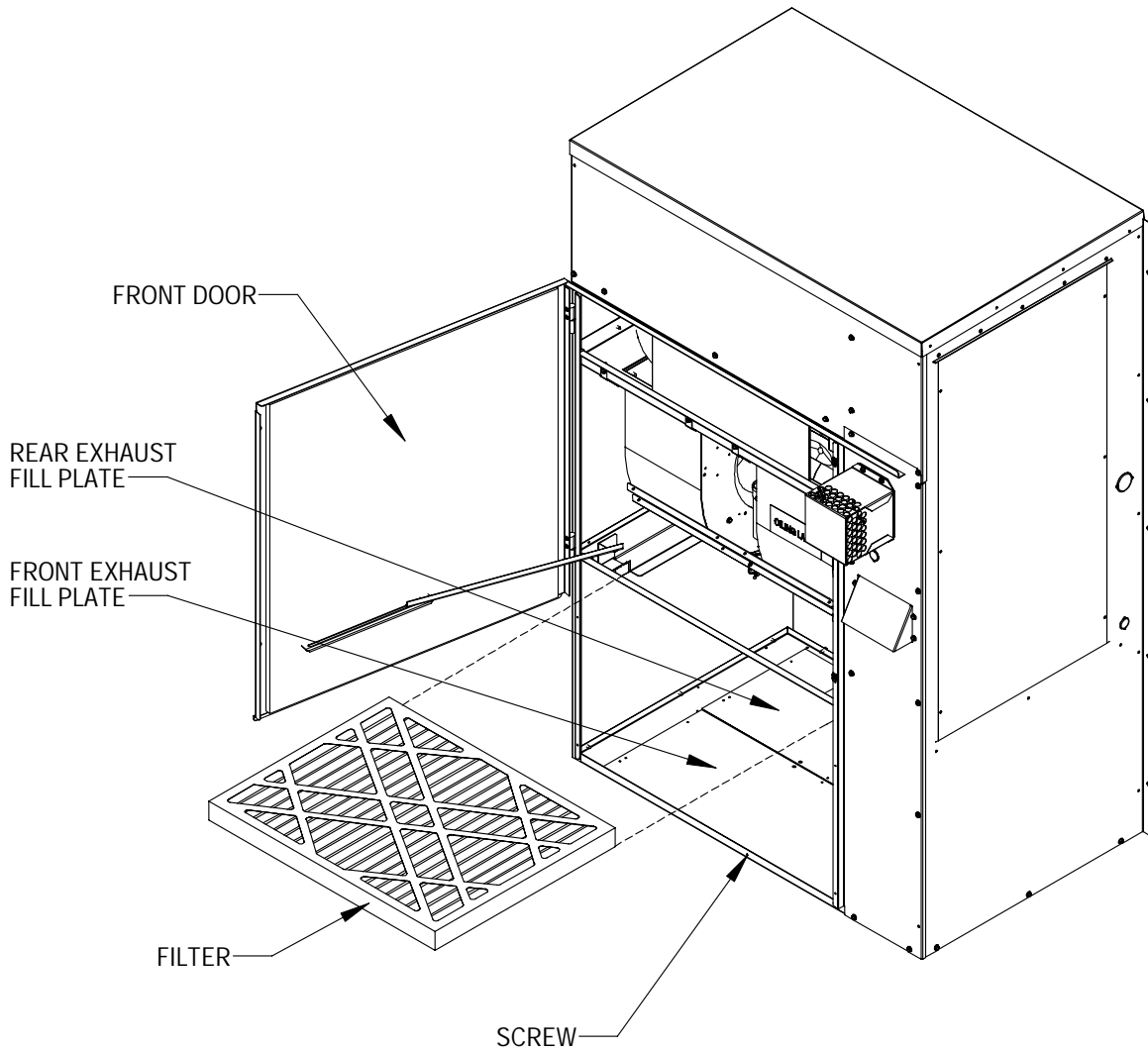
MIS-2348

**FIGURE 2**  
**REMOVE VENT OPTION DOOR**



MIS-2350

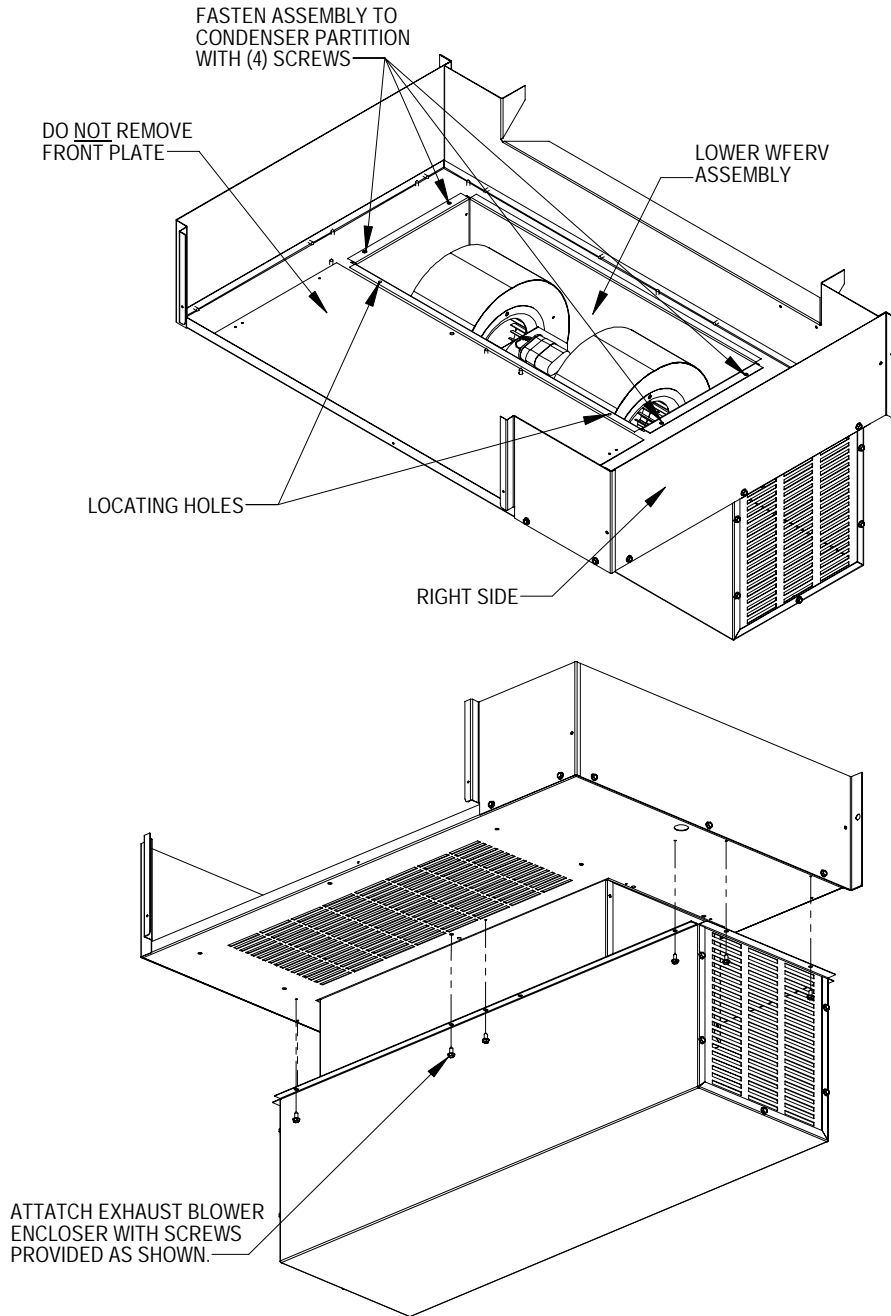
**FIGURE 3**  
**FILTER AND EXHAUST PLATE LOCATION**



MIS-2345

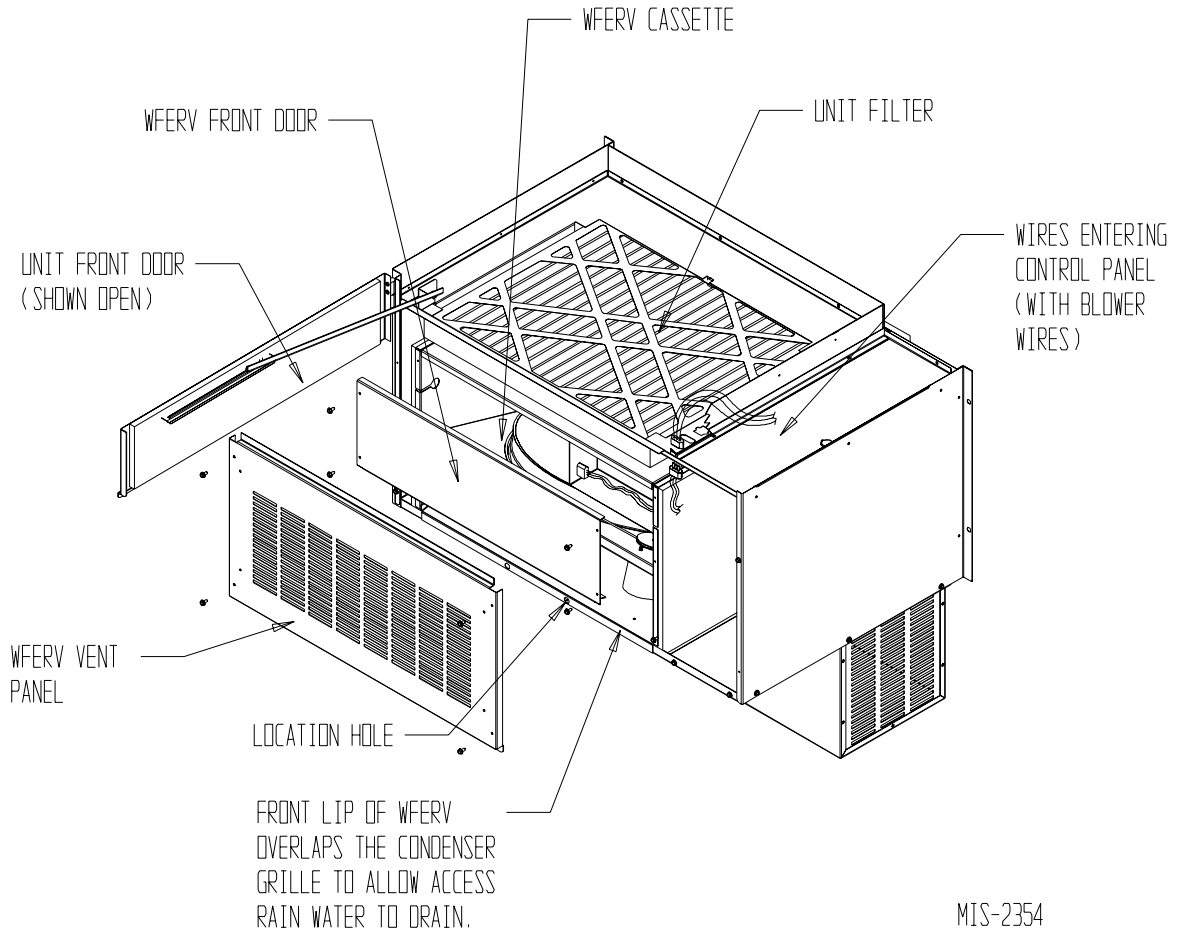


**FIGURE 4**  
**INSTALLATION OF EXHAUST BLOWER ASSEMBLY**



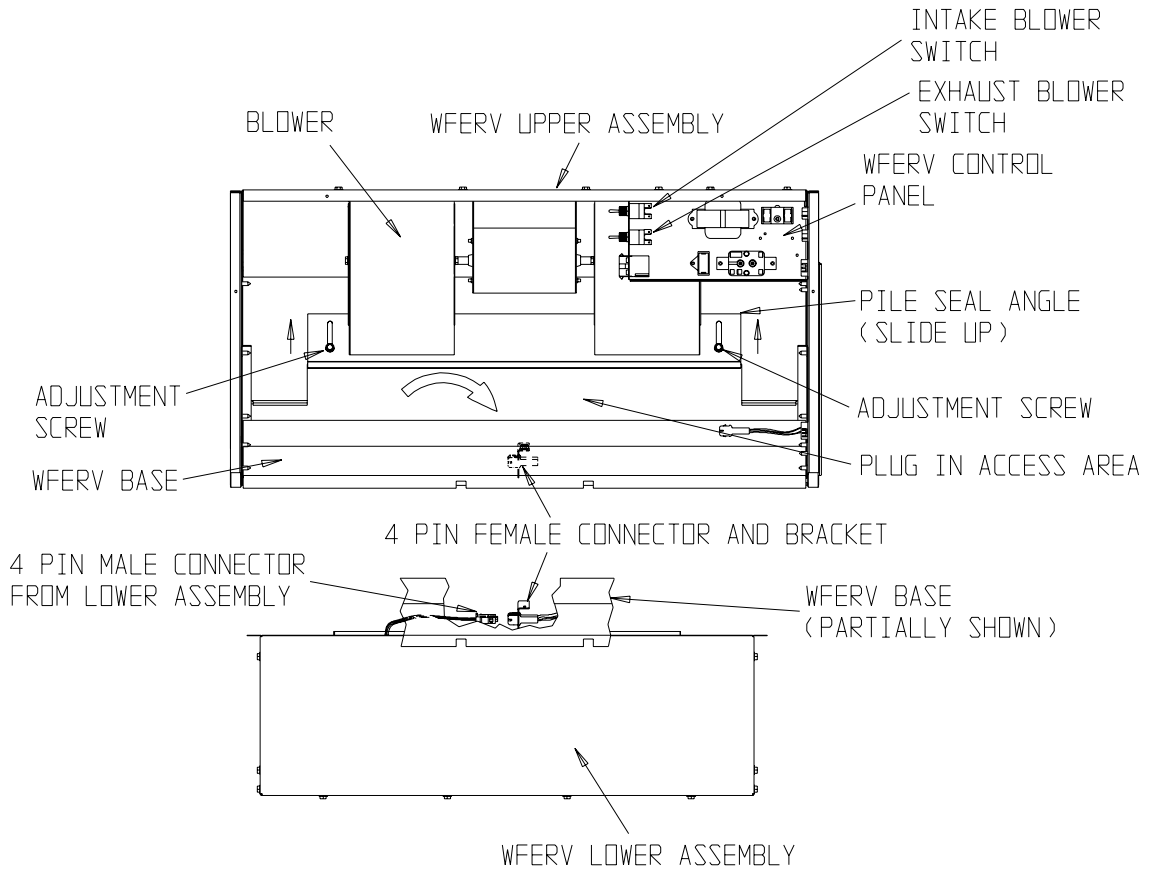
MIS-2353

**FIGURE 5  
INSTALLATION OF WFERV**



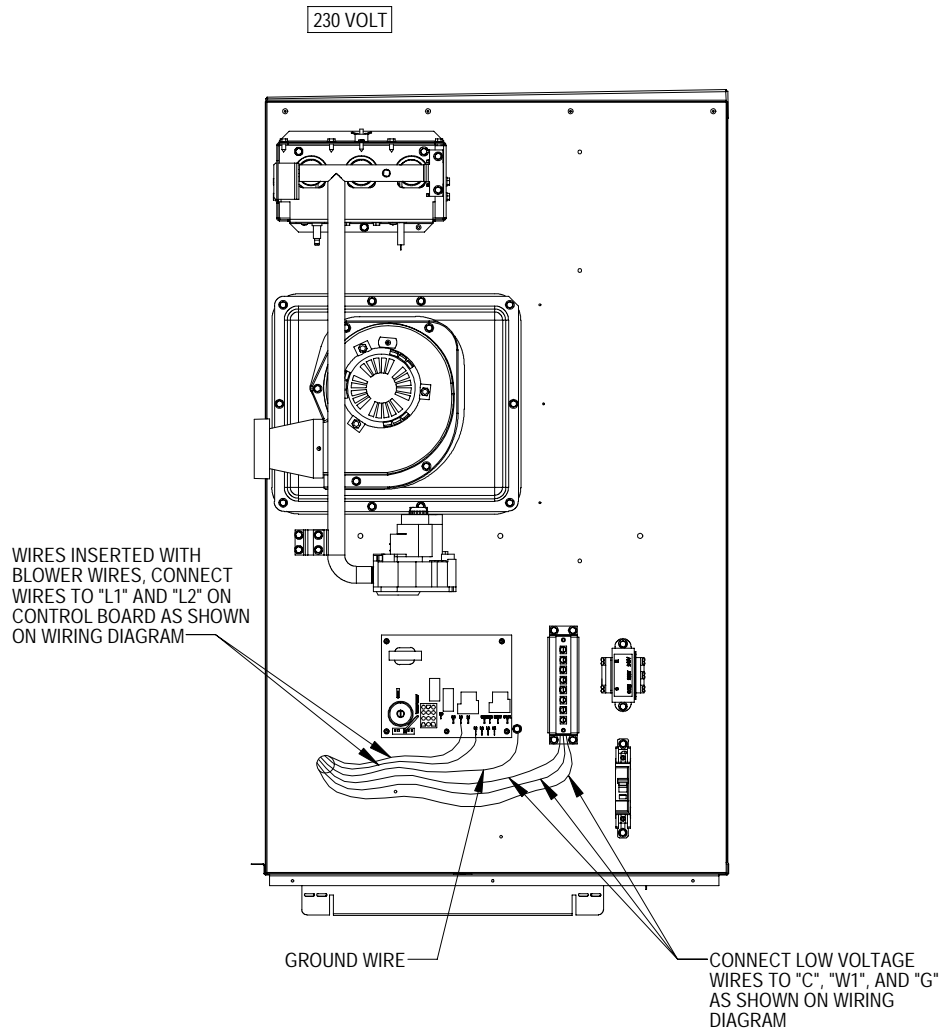
MIS-2354

**FIGURE 6  
WFERV ASSEMBLY**



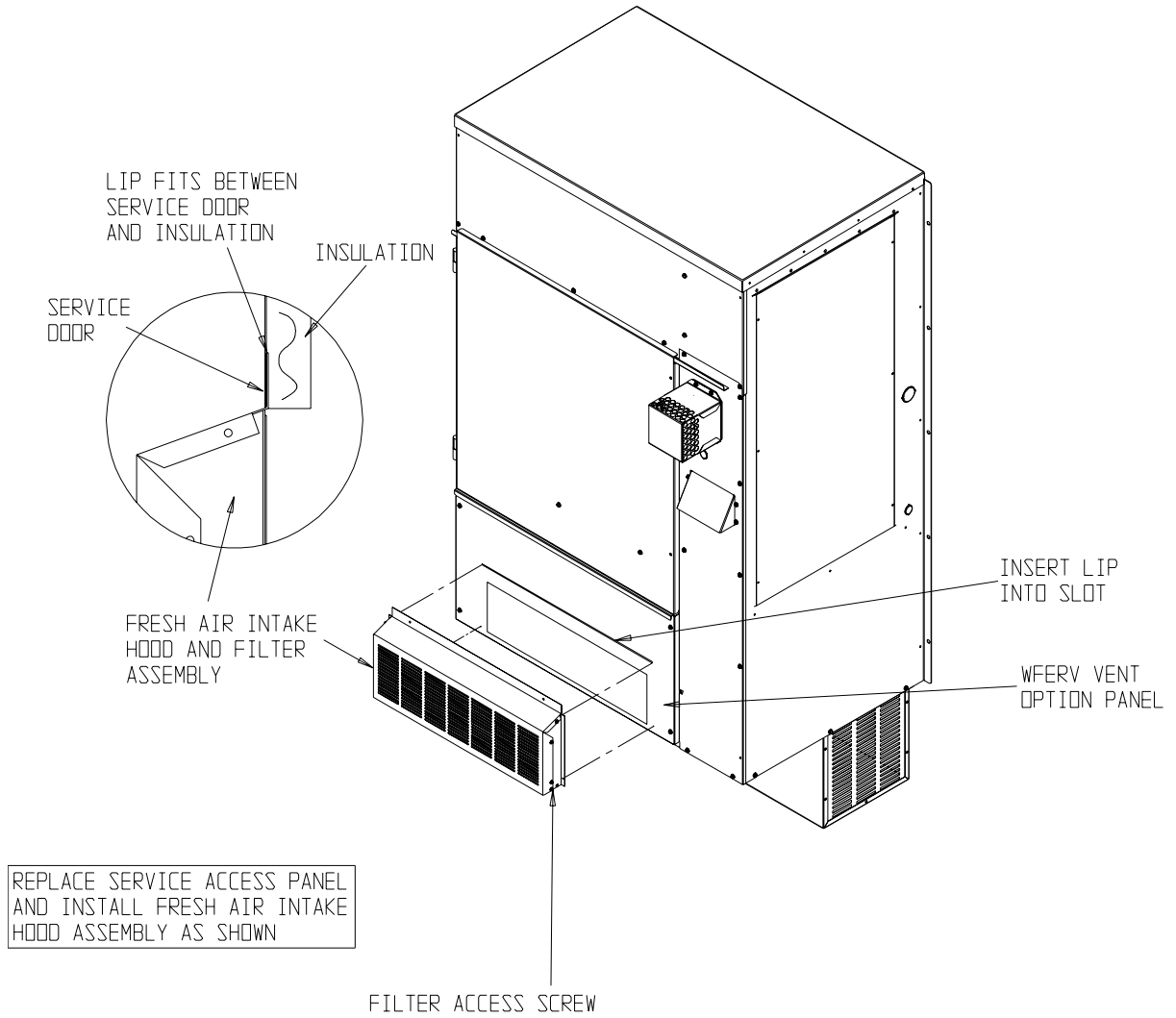
MIS-2355

**FIGURE 7**  
**WIRING - 230 VOLT**



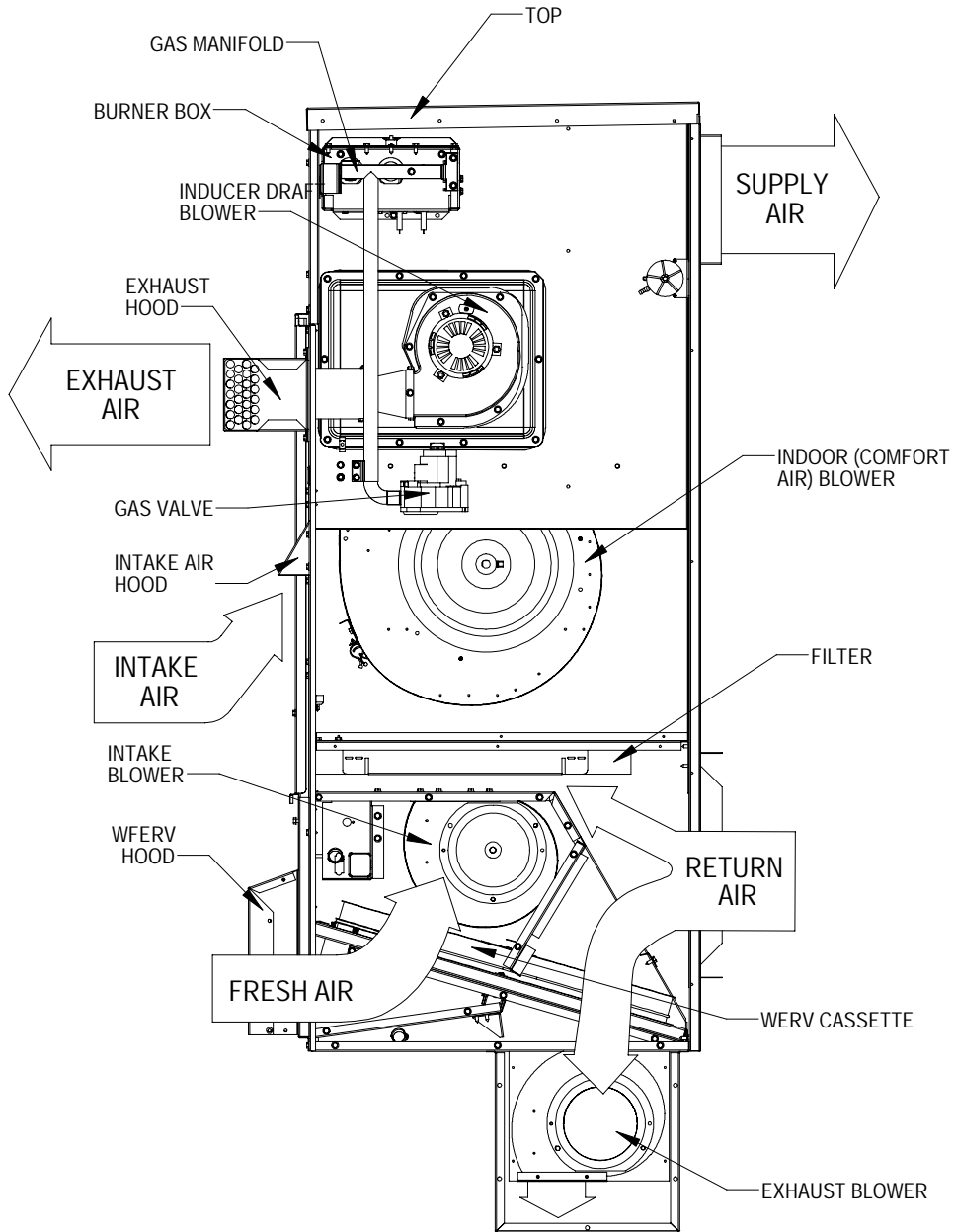
MIS-2356

**FIGURE 8**  
**INSTALLATION OF FRESH AIR INTAKE HOOD ASSEMBLY**



MIS-2357

**FIGURE 9  
OPERATION OF UNIT WITH WFERV INSTALLED**



MIS-2369

## BASIC INSTALLATION (FACTORY INSTALLED VERSIONS)

1. Remove air intake hood from return air area of unit. (See Figure 1.)
2. Install air intake hood. Refer to Item 17 of Basic Installation (Field Installation).
3. Refer to Control Wiring section for suggested control schemes for the WFERV.
4. After wiring, replace all panels.

## CONTROL WIRING

The WFERV comes from the factory with the low voltage control wires wired into the wall mount low voltage terminal strip (see wiring diagrams). Care must be taken when deciding how to control the operation of the ventilator. When designing the control circuit for the ventilator, the following requirements must be met.

## CONTROL REQUIREMENTS

1. Indoor blower motor must be run whenever the WFERV is run.
2. Select the correct motor speed tap in the WFERV. Using Table 1 of the WFERV Installation Instructions, determine the motor speed needed to get the desired amount of ventilation air needed. For instance, do not use the high speed tap on a WFERV if only 200 CFM of ventilation air is needed. Use the low speed tap. Using the high speed tap would serve no useful purpose and significantly affect the overall efficiency of the system. System operating cost would also increase.
3. Run the WFERV only during periods when the conditioned space is occupied. Running the WFERV during unoccupied periods wastes energy, decreases the expected life of the WFERV, and can result in a large moisture buildup in the structure. The WFERV removes 60 to 70% of the moisture in the incoming air, not 100% of it. Running the WFERV when the structure is unoccupied allows moisture to build up in the structure because there is little or no load. Use a control system that in some way can control the system based on occupancy.

## \* \* IMPORTANT \* \*

Operating the WFERV during unoccupied periods can result in a build up of moisture in the structure.

## RECOMMENDED CONTROL SEQUENCES

Several possible control scenarios are listed below:

1. Use a programmable electronic thermostat with auxiliary terminal to control the WFERV based on daily programmed occupancy periods.
2. Use a motion sensor in conjunction with a mechanical thermostat to determine occupancy in the structure. Bard markets the CS2000 for this use.
3. Use a DDC control system to control the WFERV based on a room occupancy schedule to control the WFERV.
4. Tie the operation of the WFERV into the light switch. The lights in a room are usually on only when occupied.
5. Use a manual timer that the occupants turn to energize the WFERV for a specific number of hours.
6. Use a programmable mechanical timer to energize the WFERV and indoor blower during occupied periods of the day.

## VENTILATION AIRFLOW

The 240 volt WFERV is equipped with a 3-speed motor to provide the capability of adjusting the ventilation rates to the requirements of the specific application by simply changing motor speeds.

**TABLE 1  
VENTILATION AIR (CFM)**

VENTILATION AIR (CFM)			
Model	High Speed (Black)	Med. Speed (Blue)	Low Speed (Red)
WFERV	450	370	280

All units are factory set on High speed and can be field adjusted for lower speeds if required.

**240-Volt Units (Single switch models):** The speed of both blowers (intake and exhaust) can be controlled by a switch located on the left side of the control panel, behind the WFERV front door.

**240-Volt Units (Dual switch models):** The speed of each blower (intake and exhaust) can be controlled independently by two (2) switches located on the left side of the control panel, behind the WFERV front door. The switch located on the upper part of the control panel controls the intake blower located in the upper assembly. The switch located on the lower part of the control panel controls the exhaust blower located in the lower assembly. See Figure 6.

If desired, the intake blower can be set up for one speed and the exhaust blower set up for another speed if needed for the specific application.



## WARNING

Open circuit breaker to shut all power OFF before doing this. Failure to do so could result in injury or death due to electrical shock.

## ENERGY RECOVERY VENTILATOR MAINTENANCE

### GENERAL INFORMATION

The ability to clean exposed surfaces within air moving systems is an important design consideration for the maintenance of system performance and air quality. The need for periodic cleaning will be a function of operating schedule, climate, and contaminants in the indoor air being exhausted and in the outdoor air being supplied to the building. All components exposed to the airstream, including energy recovery wheels, may require cleaning in most applications.

Rotary counterflow heat exchanges (heat wheels) with laminar airflow are “self-cleaning” with respect to dry particles. Smaller particles pass through; larger particles land on the surface and are blown clear as the flow direction is reversed. For this reason, the primary need

for cleaning is to remove films of oil-based aerosols that have condensed on energy transfer surfaces. Buildup of material over time may eventually reduce airflow. Most importantly, in the case of desiccant coated (enthalpy) wheels, such films can close off micron sized pores at the surface of the desiccant material, reducing the efficiency with which the desiccant can absorb and desorb moisture.

### FREQUENCY

In a reasonably clean indoor environment such as a school, office building, or home, experience shows that reductions of airflow or loss of sensible (temperature) effectiveness may not occur for ten or more years. However, experience also shows that measurable changes in latent energy (water vapor) transfer can occur in shorter periods of time in commercial, institutional and residential applications experiencing moderate occupant smoking or with cooking facilities. In applications experiencing unusually high levels of occupant smoking, such as smoking lounges, nightclubs, bars and restaurants, washing of energy transfer surfaces, as frequently as every six months, may be necessary to maintain latent transfer efficiency. Similar washing cycles may also be appropriate for industrial applications involving the ventilation of high levels of smoke or oil-based aerosols such as those found in welding or machining operations, for example. In these applications, latent efficiency losses of as much as 40% or more may develop over a period of one to three years.

### CLEANABILITY AND PERFORMANCE

In order to maintain energy recovery ventilation systems, energy transfer surfaces must be accessible for washing to remove oils, grease, tars and dirt that can impede performance or generate odors. Washing of the desiccant surfaces is required to remove contaminate buildups that can reduce adsorption of water molecules. The continued ability of an enthalpy wheel to transfer latent energy depends upon the permanence of the bond between the desiccant and the energy transfer surfaces.

Bard wheels feature silica gel desiccant permanently bonded to the heat exchange surface without adhesives; the desiccant will not be lost in the washing process. Proper cleaning of the Bard energy recovery wheel will restore latent effectiveness to near original performance.

### MAINTENANCE PROCEDURES

*NOTE: Local conditions can vary and affect the required time between routine maintenance procedures, therefore all sites (or specific units at a site) may not have the same schedule to maintain acceptable performance. The following timetables are recommended and can be altered based on local experience.*



## QUARTERLY MAINTENANCE

1. Inspect mist eliminator/prefilter and clean if necessary. This filter is located in the fresh air intake hood on the front of the unit. This is an aluminum mesh filter and can be cleaned with water and any detergent not harmful to aluminum.
2. Inspect wall mount unit filter and clean or replace as necessary. This filter is located either in the unit, in a return air filter grille assembly, or both. If in the unit it can be accessed by removing the lower service door on the front of the unit. If in a return air filter grille, by hinging the grille open to gain access.
3. Inspect energy recovery ventilator for proper wheel rotation and dirt buildup. This can be done in conjunction with Item 2 above. Energize the energy recovery ventilator after inspecting the filter and observe for proper rotation and/or dirt buildup.
4. Recommended energy recovery wheel cleaning procedures follow: Disconnect all power to unit. Remove the lower service door of the wall mount unit to gain access to the energy recovery ventilator.
5. Remove the front access panel on the ventilator. Unplug amp connectors to cassette motors. Slide energy recovery cassette out of ventilator.
6. Use a shop vacuum with brush attachment to clean both sides of the energy recovery wheels.
7. Reverse shop vacuum to use as a blower and blow out any residual dry debris from the wheel.

*NOTE: Discoloration and staining of the wheel does not affect its performance. Only excessive buildup of foreign material needs to be removed.*

8. If any belt chirping or squealing noise is present, apply a small amount of LPS-1 or equivalent dry film lubricant to the belt.

## ANNUAL MAINTENANCE

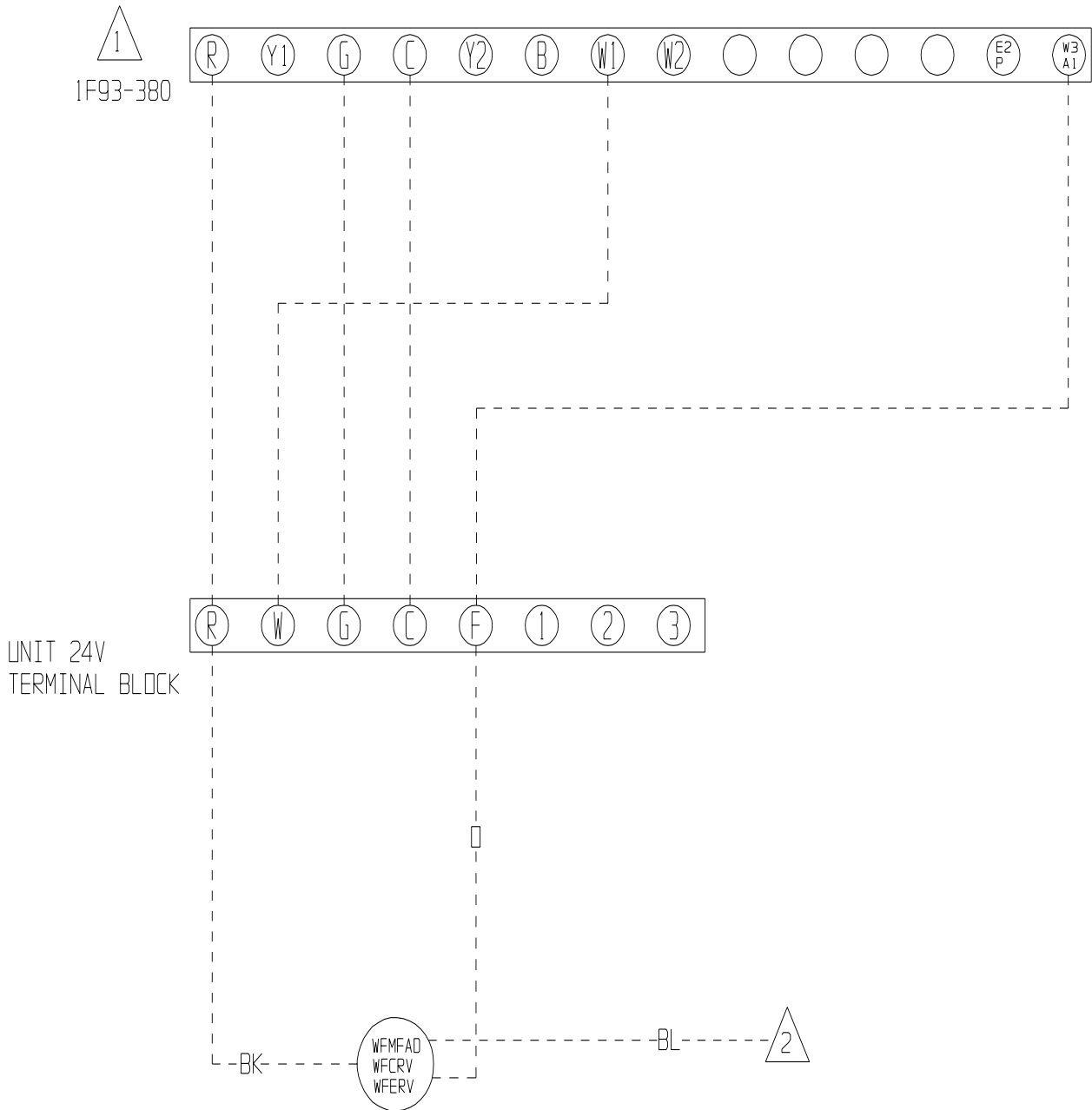
1. Inspect and conduct the same procedures as outlined under Quarterly Maintenance.
2. To maintain peak latent (moisture) removal capacity, it is recommended that the energy recovery wheels be sprayed with a diluted nonacid based evaporator coil cleaner or alkaline detergent solution such as 409.

*NOTE: Do not use acid based cleaners, aromatic solvents, temperatures in excess of 170°F or steam. Damage to the wheel may result.*

*Do not disassemble and immerse the entire heat wheel in a soaking solution, as bearing and other damage may result.*

3. Rinse wheel thoroughly after application of the cleaning solution, and allow to drain before reinstalling.
4. No re-lubrication is required to heat wheel bearings of the drive motor, or to the intake and exhaust blower motors.
5. If any belt chirping or squealing noise is present, apply a small amount of LPS-1 or equivalent dry film lubricant to the belt.

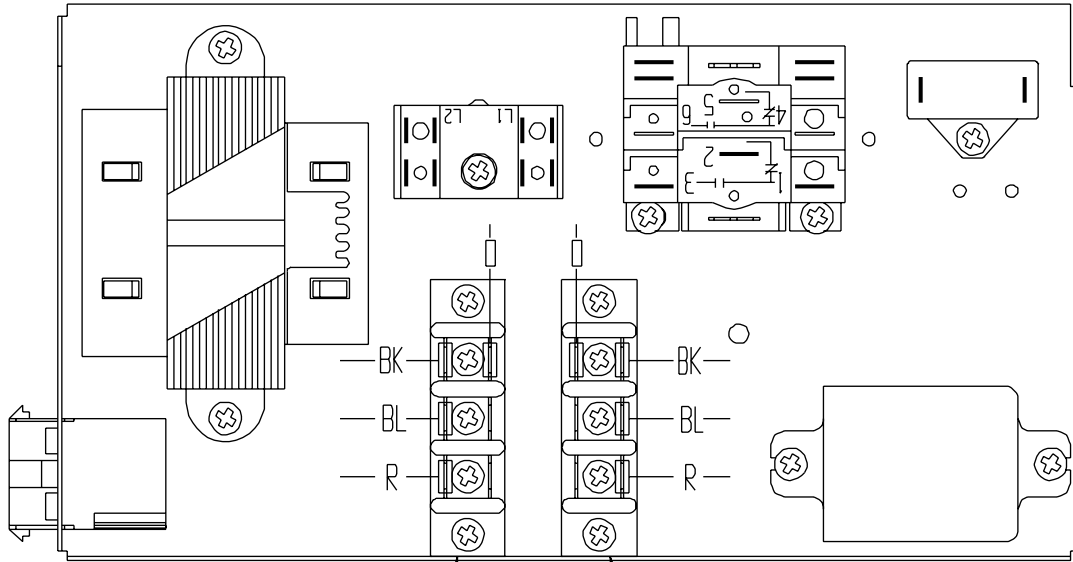
**FIGURE 10**  
**THERMOSTAT WIRING DIAGRAM**  
 WALL FURNACE



- △ 1 PROGRAM T-STAT FOR CONTINUOUS BLOWER DURING OCCUPIED PERIODS
- △ 2 TAPE OFF BLUE WIRE

MIS-2370

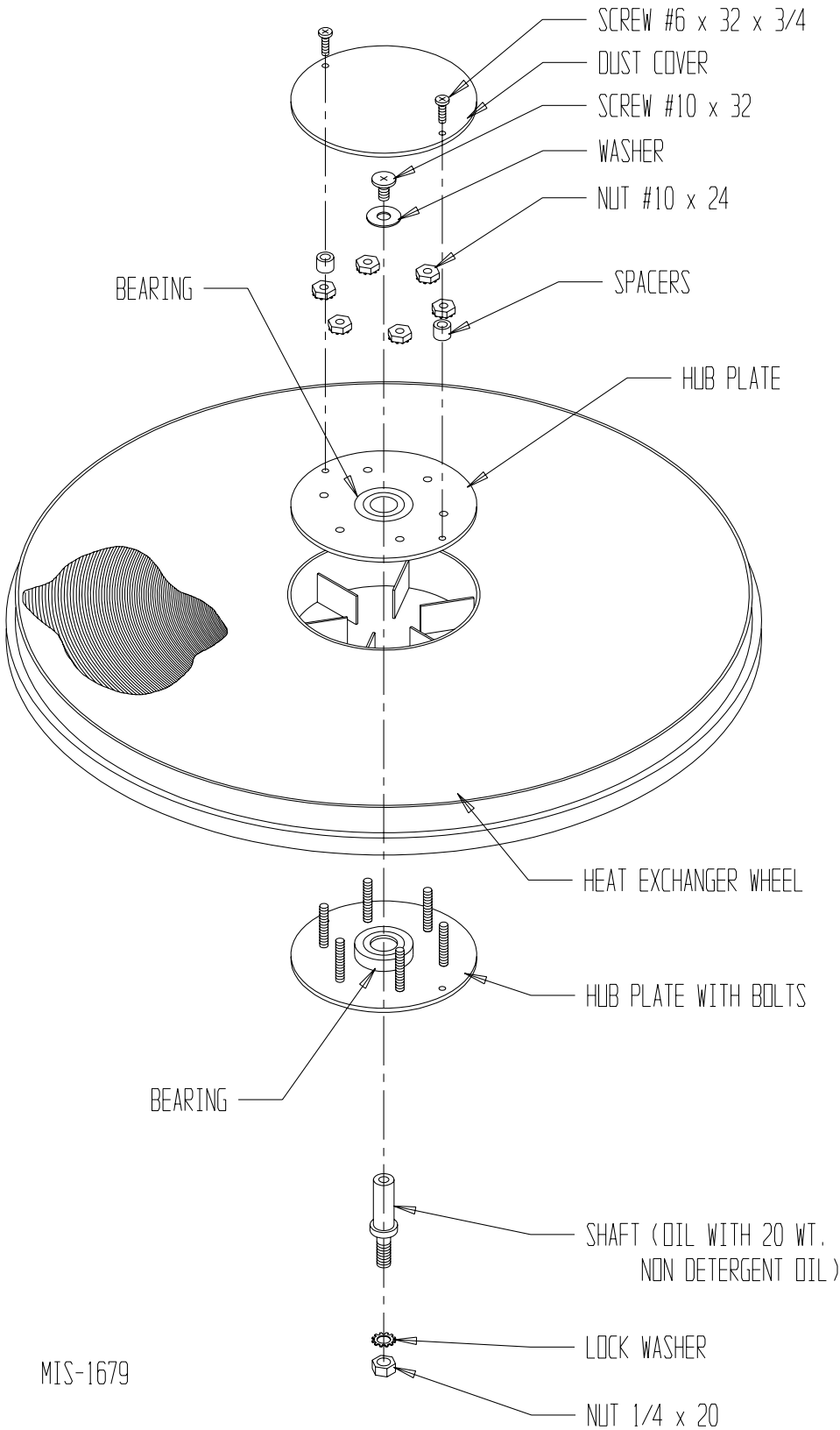
**FIGURE 11**  
**TERMINAL BLOCK LOCATION**



INTAKE BLOWER MOTOR CONNECTIONS, FACTORY SET ON HIGH SPEED. FOR LOW SPEED OPERATION MOVE "ORANGE" LEAD ON TERMINAL BLOCK TO "RED" LEAD ON TERMINAL BLOCK AND "BLACK" LEAD ON TERMINAL BLOCK TO "BLUE" LEAD ON TERMINAL BLOCK. SEE WIRING DIAGRAM.

EXHAUST BLOWER MOTOR CONNECTIONS, FACTORY SET ON HIGH SPEED. FOR LOW SPEED OPERATION MOVE "ORANGE" LEAD ON TERMINAL BLOCK TO "RED" LEAD ON TERMINAL BLOCK AND "BLACK" LEAD ON TERMINAL BLOCK TO "BLUE" LEAD ON TERMINAL BLOCK. SEE WIRING DIAGRAM.

**FIGURE 12  
HUB ASSEMBLY WITH BALL BEARING**



MIS-1679

