
INSTALLATION INSTRUCTIONS

ECONOMIZER WITH EXHAUST

MODEL
WGEIFM-3C
WGEIFM-5C
WGSEIFM-5

For Use with Bard 3 - 5 Ton Step Capacity
and
2 - 5 Ton Single Stage
Wall Mount Air Conditioners with Gas Heat



Climate Control Solutions

Bard Manufacturing Company, Inc.
Bryan, Ohio 43506
Since 1914...Moving ahead just as planned.

Manual : 2100-498C
Supersedes: 2100-498B
File: Volume III Tab 19
Date: 06-25-13

CONTENTS

General

General Information	3
Unpacking	3
Description	3
Models	3

Installation

Basic Installation	4, 5, 7, 8
Economizer Sequence of Operation	
Condition A – Cool Outdoors	16
Economizer Sequence of Operation	
Condition B – Warm Outdoors	17

Figures

Figure 1	Removal of Exterior Panels	4
Figure 2	Installation of Economizer	5
Figure 3	Install Loose Piece Wire Harness	6
Figure 4	WGSEIFM-5 Wiring Diagram	7
Figure 5	Economizer Logic Module	9
Figure 6	Economizer Op - Single Compressor	15
Figure 7	Call for Blower Operation	16
Figure 8	Call for Cooling Operation	17

Tables

Table 1	3
Table 2	8

Graphs

WG3S Ventilation Airflow	10
WG4S Ventilation Airflow	10
WG5S Ventilation Airflow	11
W24G EIFM Ventilation Airflow	12
W30G-W36G EIFM Ventilation Airflow	13
W42G-W60G EIFM Ventilation Airflow	14

BARD MANUFACTURING COMPANY, INC.
BRYAN, OHIO USA 43506

GENERAL

GENERAL INFORMATION

The ventilator should only be installed by a trained heating and air conditioning technician. These instructions serve as a guide to the technician installing the ventilator package. They are not intended as a step by step procedure with which the mechanically inclined owner can install the package.

The ventilator housing is shipped in one carton which contains the electrical harness, miscellaneous hardware and installation instructions.

The economizer installation will function normally with the 2-stage thermostats already specified for usage with this 2-stage cooling unit.

If the “free cooling” of the economizer cannot keep up with the cooling demand, it will de-energize the economizer and will then operate on 2nd stage mechanical cooling. **Because of this, all units equipped with an economizer need to be equipped with the low ambient control.** For field installed applications, install Bard Low Ambient Control Kit per Table (below):

W24G1 - W60G1	CMA-6
WG3S - WG5S	CMA-28
W24G1D - W60G1D	CMA-28

If using a Bard Master Controller, the Bard MC4000 controller is designed to control two (2) redundant Bard Wall Mount units equipped with economizers. Refer to the MC4000 Installation Manual (or consult Bard Technical Service) for the required connections and sequence of operation.

UNPACKING

Upon receipt of the equipment be sure to compare the model number found on the shipping label with the accessory identification information on the ordering and shipping document to verify that the correct accessory has been shipped.

Inspect the carton housing of each ventilator as it is received, and before signing the freight bill, verify that all items have been received and that there is no visible damage. Note any shortages or damage on all copies of the freight bill. The receiving party must contact the last carrier immediately, preferably in writing, requesting inspection by the carrier’s agent. Concealed damage not discovered until after loading must be reported to the carrier within 15 days of its receipt.

DESCRIPTION

The WGEIFM-3C economizer is designed to be used with Bard W24G to W36G 1-stage cooling, 1-stage heating gas electric model wall mounts that are equipped with fan cycling controls. The WGSEIFM-5 economizer is designed to be used with Bard WG*S 2-stage cooling and W42-60G 1-stage cooling, 1-stage heating gas electric model wall mounts that are equipped with fan cycling controls. They are an electromechanical economizer system designed to provide “free” cooling where the outdoor air temperature is cool enough to provide the needed cooling without running the compressor. When cooling is needed, the system automatically takes advantage of the cold outdoor air when available, and uses it for first stage cooling. Thus reducing the need to run the air conditioning compressor – providing lower operating costs and increasing the service life of the equipment. If the outdoor air gets too warm or humid to be helpful, the enthalpy control detects the condition and automatically operates the internal damper and switches on the mechanical cooling. This is all accomplished automatically without attention from the user to achieve maximum savings. See Figure 6 for a block diagram of the economizer operation logic flow. The unit is equipped with a full modulating type damper motor, which controls the damper position to a factory set minimum supply air temperature.

MODELS

When installed in model series (refer to Table 1), all EIFM models provide built in exhaust provisions. When the damper blade opens to bring fresh air in, the damper also opens an exhaust relief. The exhaust air will flow into the condenser section of the unit. The condenser fan will help draw exhaust air out.

TABLE 1

MODEL	FOR USE WITH FOLLOWING UNITS
WGSEIFM-5	WG3S WG4S WG5S
WGEIFM-3C	W24G W30G W36G
WGEIFM-5C	W42G W48G W60G

INSTALLATION

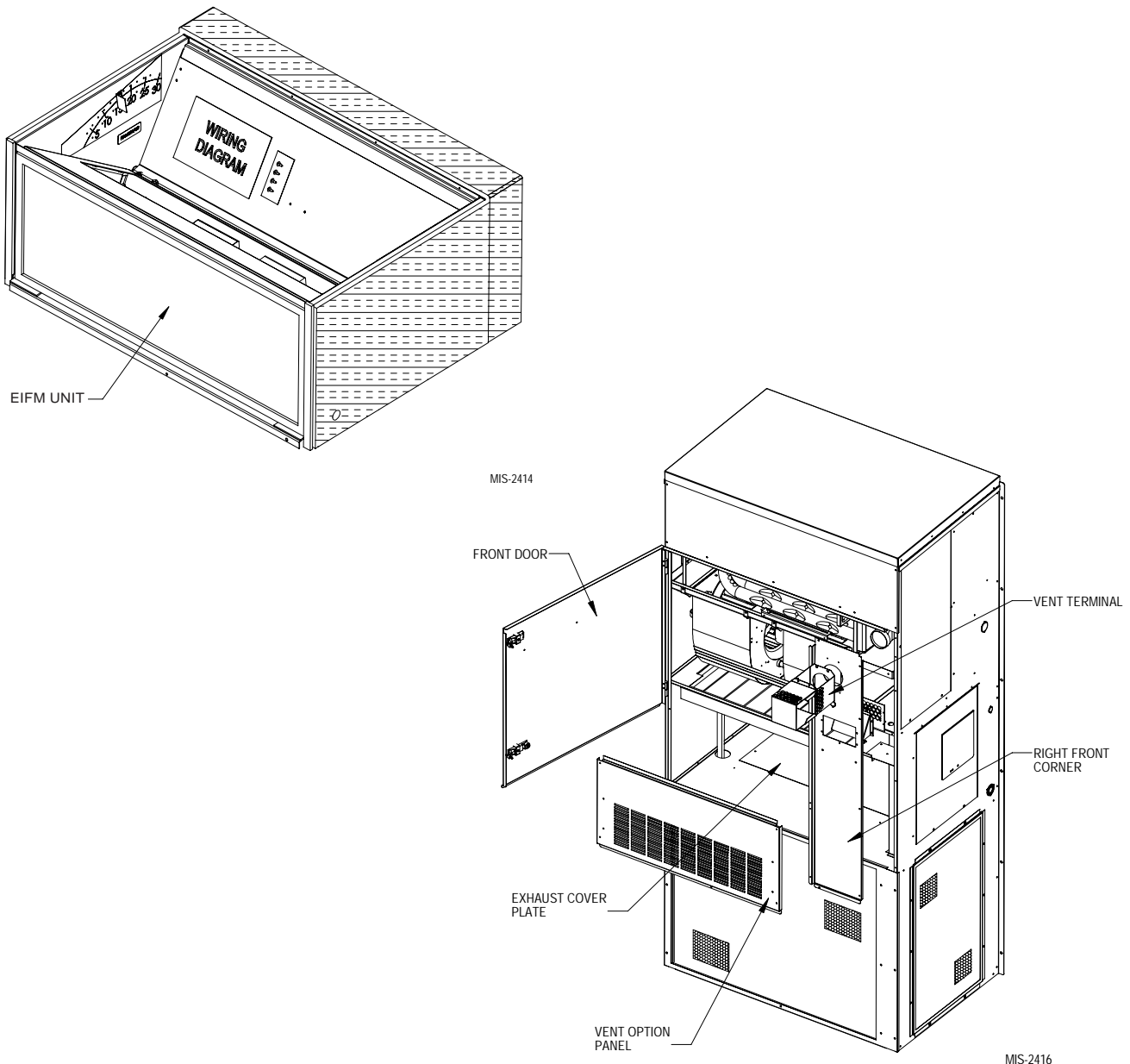
WARNING

Open and lock unit disconnect switch before installing this accessory to prevent injury or death due to electrical shock or contact with moving parts. Turn thermostat to off.

BASIC INSTALLATION

1. Unpack the ventilator assembly which includes the integral ventilator with attached electrical harness, blank-off plate and miscellaneous hardware.
2. Remove and save the existing exterior blower access and service access panels (see Figure 1).
3. Remove and discard exhaust cover plate (see Figure 1).
4. In rear of opening towards duct connection, install exhaust opening adaptor plate (included).

**FIGURE 1
REMOVAL OF EXTERIOR PANELS**

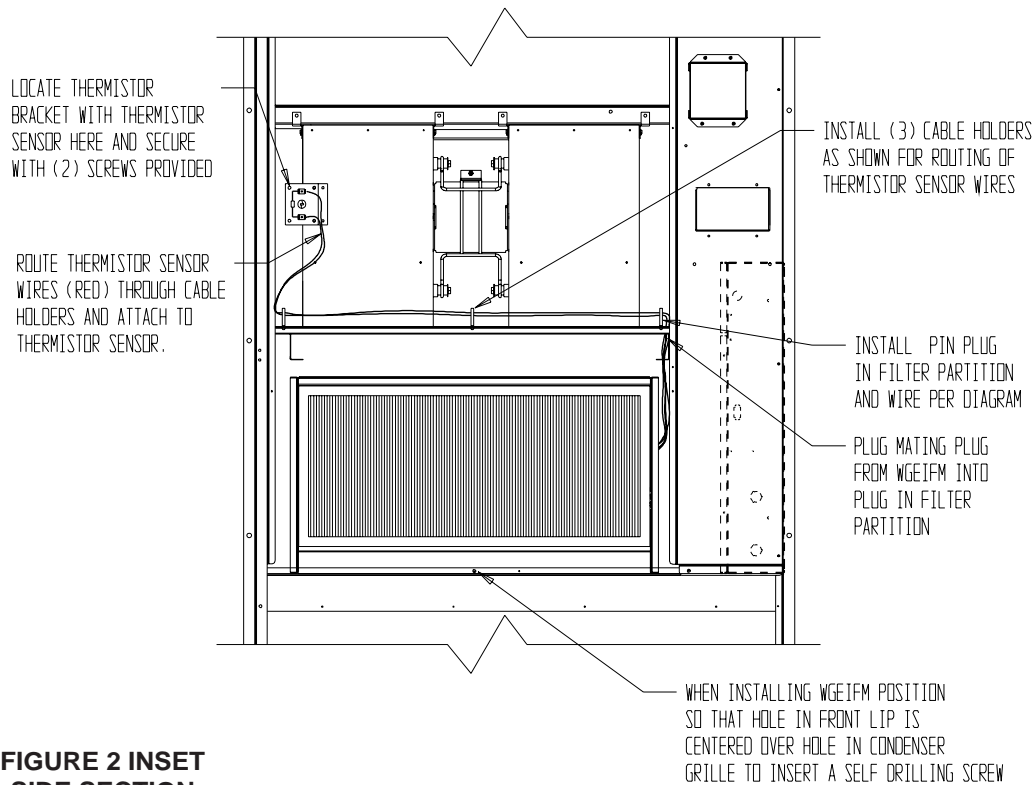


5. Install ventilator sheet metal assembly by inserting the ventilator into the unit – centering between the tubing on the left and the control panel on the right. Once the ventilator is fully inserted, slide the ventilator to align screw hole through the front of the condenser grille. (See Figure 2.)

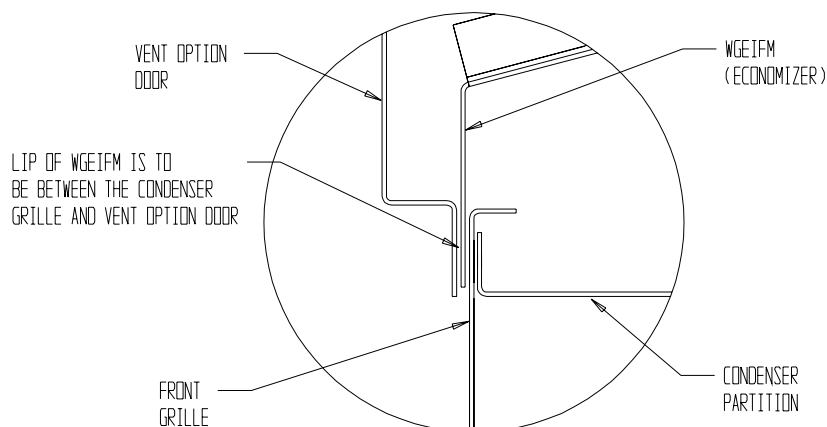
IMPORTANT: Position front lip of ventilator on top of front grille and condenser partition. (See Figure 2 inset.) This is important to ensure proper drainage of any water entering damper assembly.

6. Open control panel to gain access to unit low voltage terminal block.
7. Install loose piece wire harness plug into filter tray & route wires into low volt box. (See Figure 3.) (Save back two {2} long red wires with push-on terminals.)
8. Plug wire plug from vent package installed in Steps #1 through #6 into plug installed in Step #7.

**FIGURE 2
INSTALLATION OF ECONOMIZER**

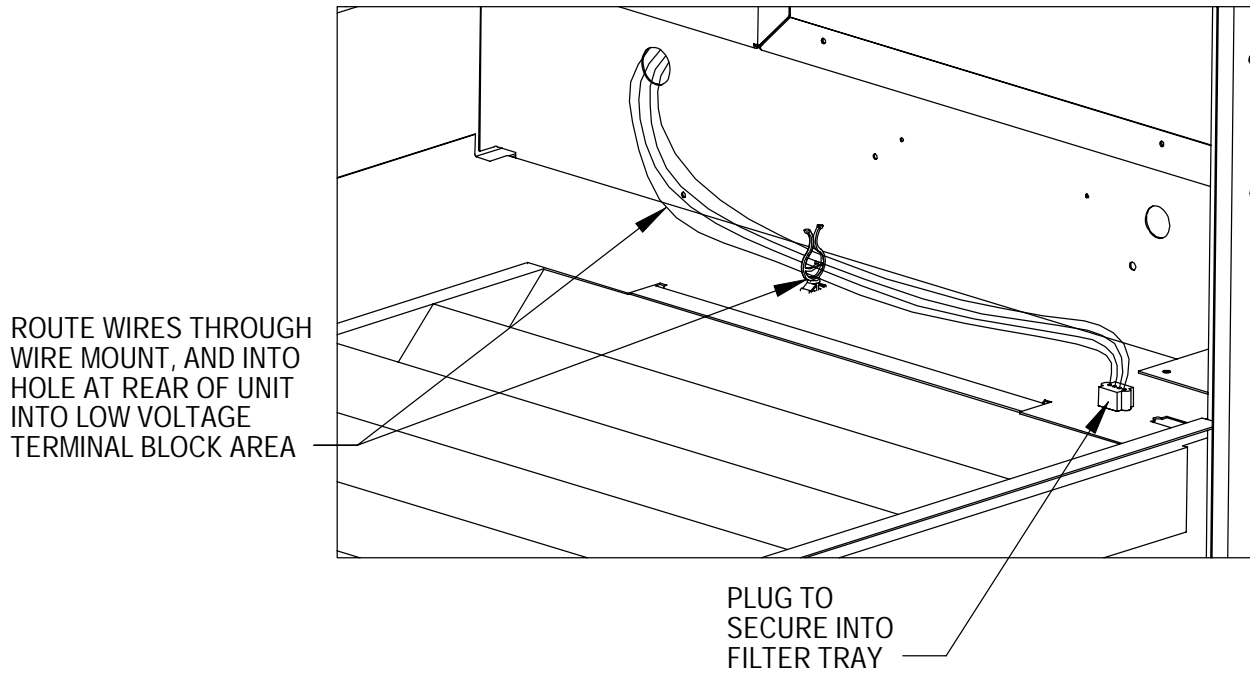


**FIGURE 2 INSET
SIDE SECTION**



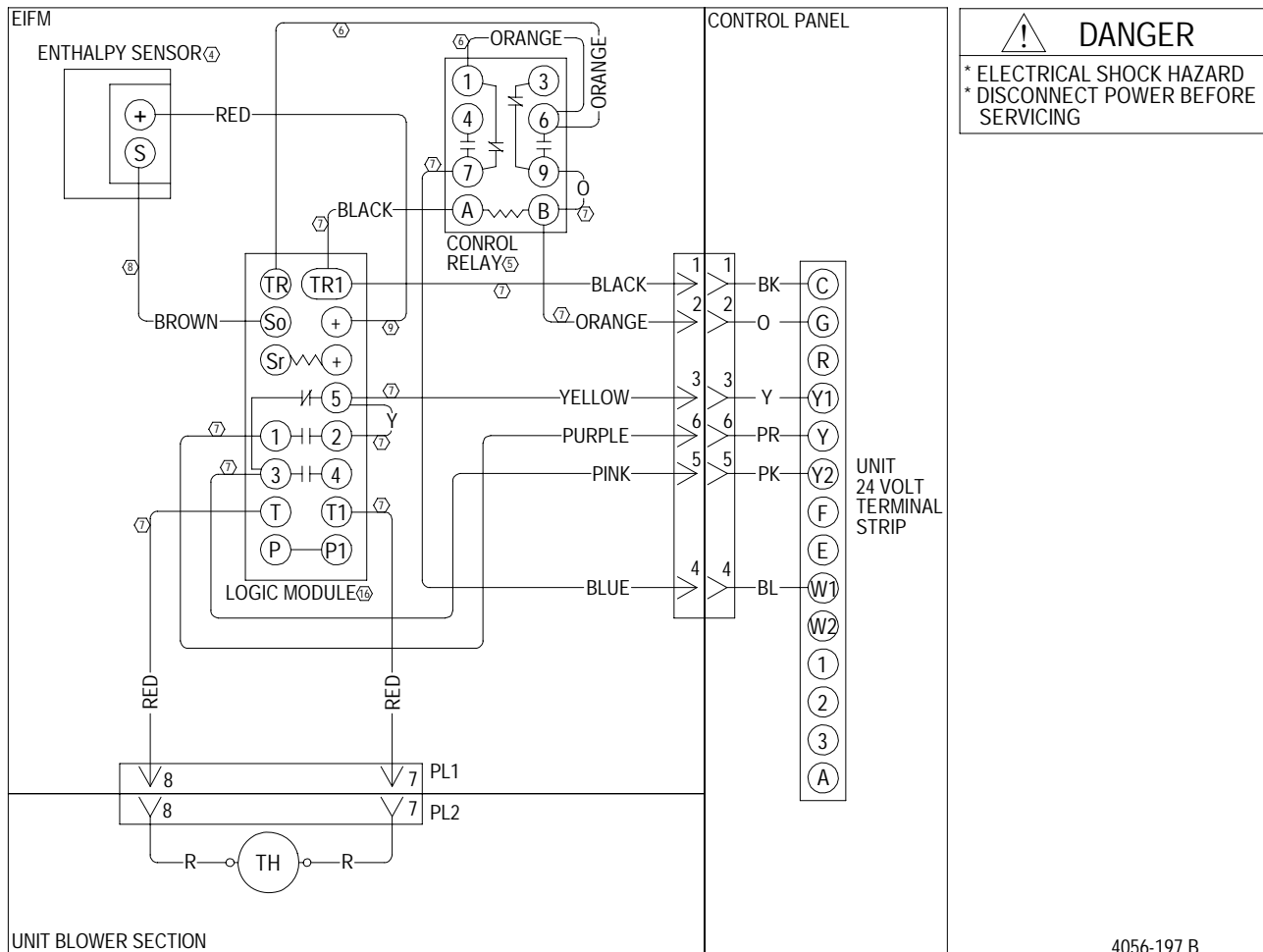
MIS-1625 A

**FIGURE 3
INSTALL LOOSE PIECE
WIRE HARNESS PLUG**



MIS-2415

**FIGURE 4
WGSEIFM-5 WIRING DIAGRAM**



9. Mount mixed air thermistor sensor to blower as shown with screws provided. Route two (2) red wires from wire harness installed in Step #7 through cable holders, and connect to thermistor sensor as shown in Figure 2.
10. Connect the wires (with fork connectors) routed into the low voltage box in Step #7 to the low voltage terminal strips as follows per wiring diagram on Figure 4:
 - Black to "C"
 - Orange to "G" (unless thermostat doesn't have occupancy signal)
 - Yellow to "Y1"
 - Purple to "Y"
 - Pink to "Y2"
 - Blue to "W1"
11. Replace right front unit corner and vent terminal.
12. Close upper unit door to seal blower discharge air.
13. Economizer Check Out
 - A. Remove mist eliminator (Figure 2). Locate the minimum position potentiometer. (See Figure 5.)
 - B. Energize the evaporator blower by switching thermostat to the manual fan position with heat/cool in the OFF position.
 - C. Cycle the minimum position potentiometer (factory set for 0% fresh air) 0 to full open. (See Figure 5.) Throughout checkout procedure observe operation of damper to insure there is free, unobstructed operation through the entire angle of damper travel. Then adjust the damper minimum open position to meet local codes or application requirements. See example below.

EXAMPLE:

1. Measure return air temperature (RAT) (assume 75° F for example).
 2. Measure outdoor air temperature (OAT) (assume 60° F for example).
 3. Calculate the mixed air temperature (MAT) which will result from the desired combination of OAT (10 percent) and RAT (90 percent).
 $.1 \text{ OAT} + .9 \text{ RAT} = \text{MAT}$
 or substituting example values
 $.1 (60^\circ \text{ F}) + .9 (75^\circ \text{ F}) = 73.75^\circ \text{ F}$
 4. Adjust the minimum position potentiometer knob until proper mixed air temperature as calculated above is reached. Care should be taken to insure thermometer is sensing air that is well mixed.
 5. Mark correct setting on dial of minimum position potentiometer for future reference.
- D. Adjust the economizer logic module to position A, B, C and D to achieve the maximum combination of temperature and humidity acceptable for the installation as per Table 2. The suggested setting is between A & B 70° DB @ 55 percent RH. It is further recommended to always set the control at C or above.) (See Figure 5.)
- E. Switch the thermostat fan control to automatic and position the heat/cool switch to cool.

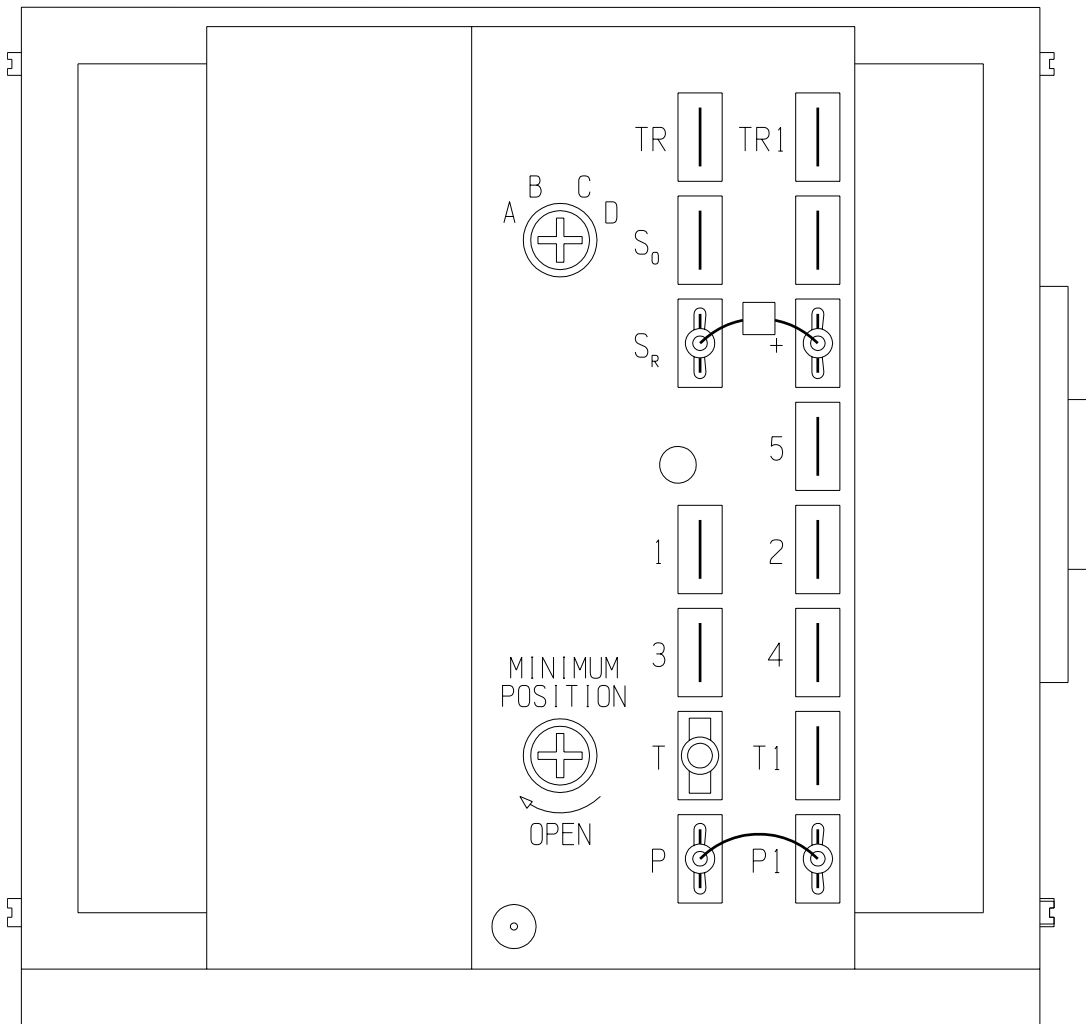
Adjust the thermostat temperature to engage the first stage of cooling only (Y). This will cause the dampers to modulate to achieve mixed air temperature of 55° provided outside air enthalpy is sufficiently low. If enthalpy is too high for economizing, low enthalpy can be simulated by temporarily removing and jumping leads on terminals 2 and 3 of enthalpy control together. This will also cause the economizer damper to modulate away from minimum position. *(Be sure to properly reconnect leads at end of checkout procedure).*

- F. Readjust temperature on the thermostat to engage the second stage of cooling (Y2). The damper motor should return to previously set minimum position. Compressor motor should start.
 - G. Switch thermostat to OFF fan and OFF heat/cool positions to de-energize unit. Economizer damper should return to full closed (100 percent return air) position. Checkout is complete.
14. Replace control access panel and mist eliminator.
 15. Remove blank off plate or barometric fresh air damper if installed on the service access panel. Plug the four (4) holes used to mount the BOP or BFAD with the plastic plugs supplied with the economizer.
 16. Replace service access panel.
 17. Economizer is now ready for operation.

**TABLE 2
ECONOMIZER LOGIC CONTROL SETTING**

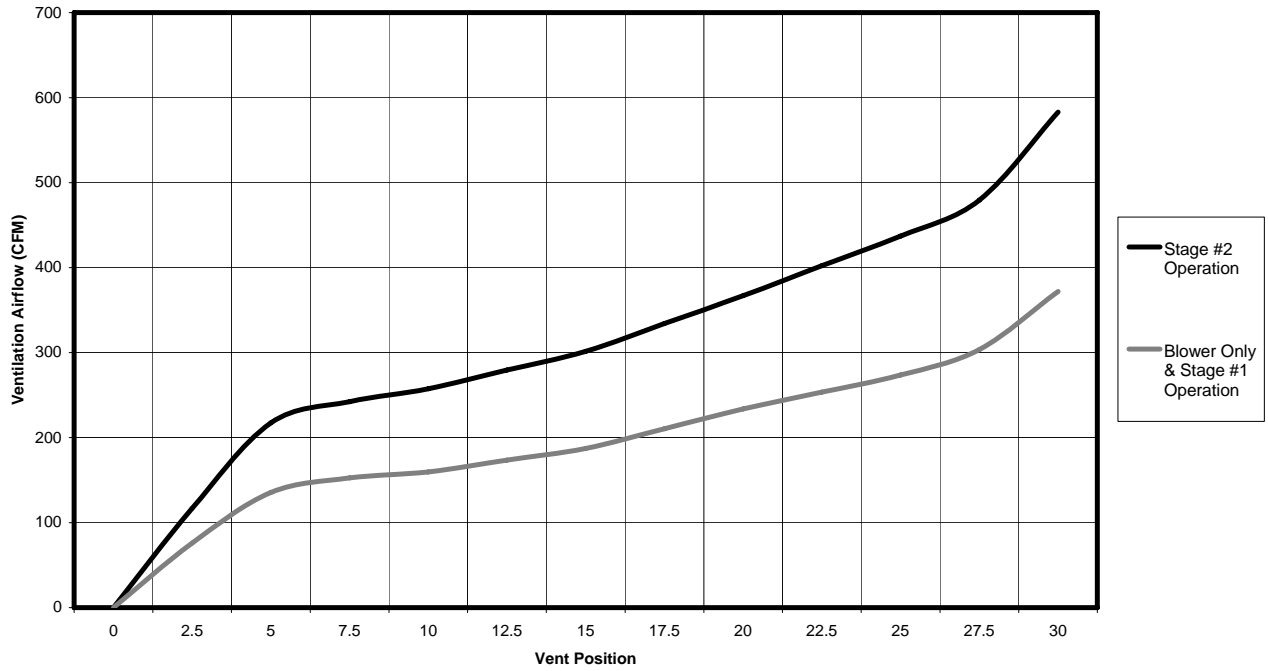
	Dial Setting	20% RH	50% RH	80% RH
Enthalpy Control Setting	A	80 deg. F (26 deg. C)	73 deg. F (23 deg. C)	66 deg. F (19 deg. C)
	B	76 deg. F (24 deg. C)	70 deg. F (21 deg. C)	63 deg. F (17 deg. C)
	C	74 deg. F (23 deg. C)	66 deg. F (19 deg. C)	59 deg. F (15 deg. C)
	D	71 deg. F (21 deg. C)	63 deg. F (17 deg. C)	54 deg. F (12 deg. C)

**FIGURE 5
ECONOMIZER LOGIC MODULE**

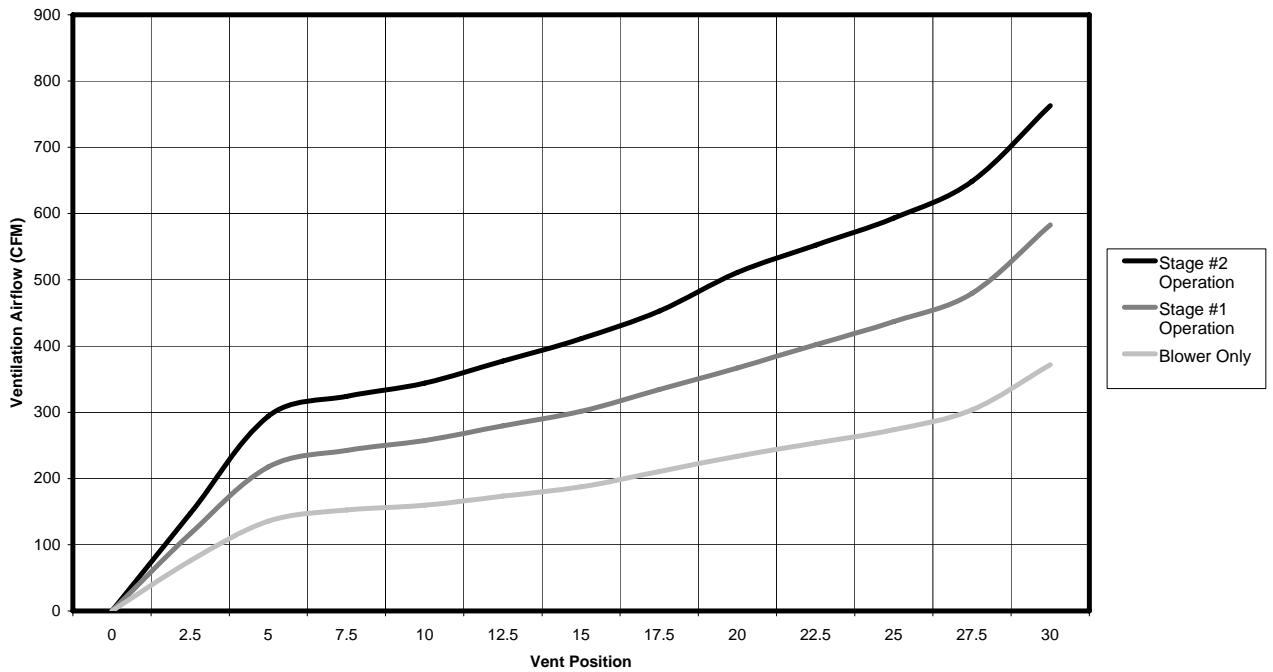


MIS-1146

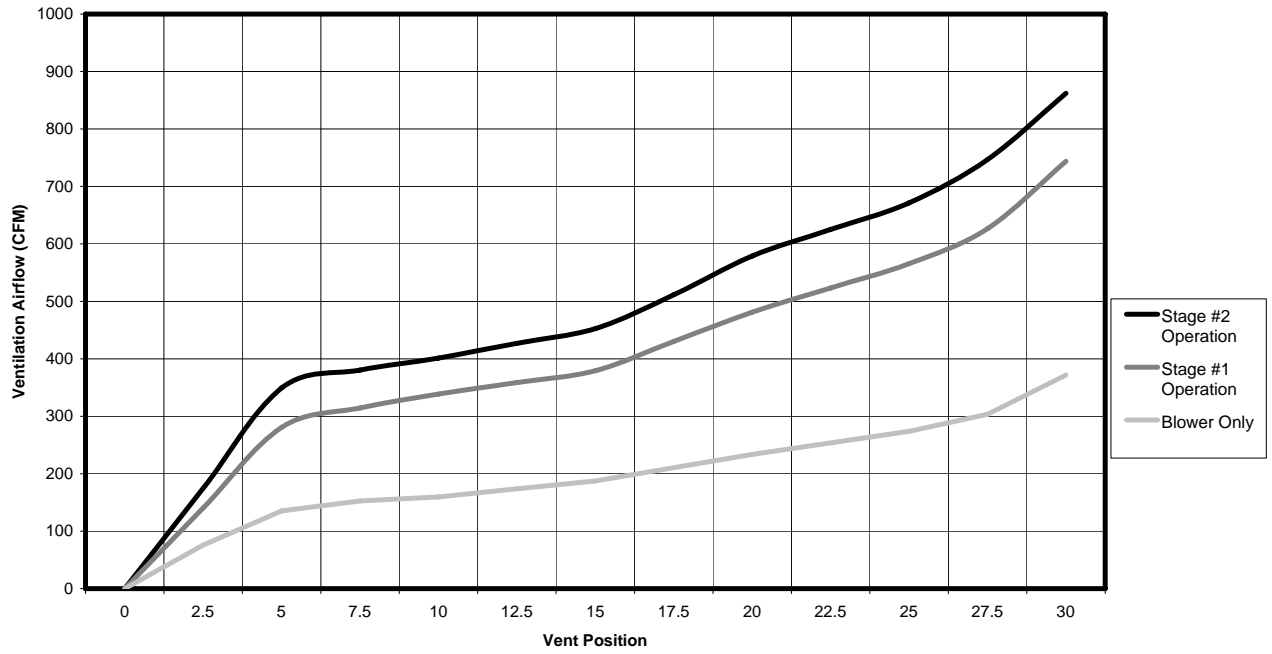
WG3S Ventilation Airflow



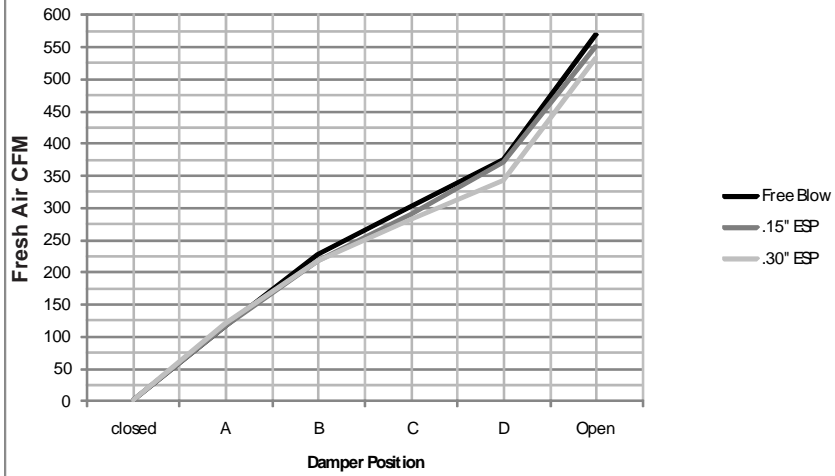
WG4S Ventilation Airflow



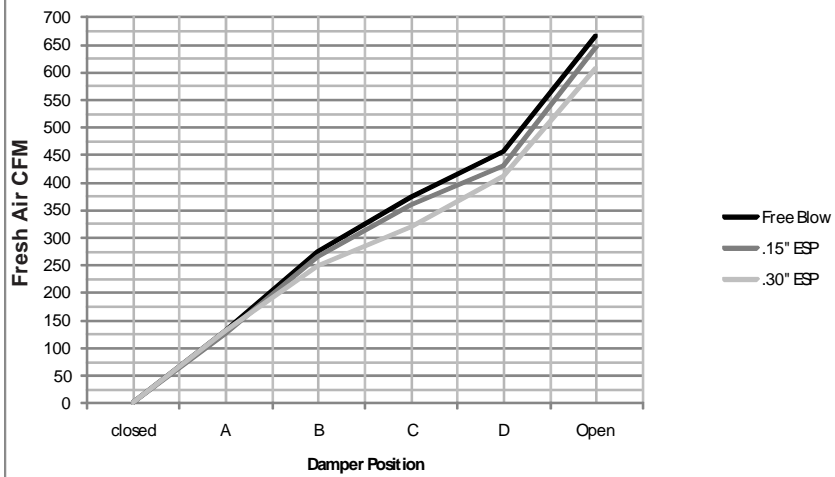
WG5S Ventilation Airflow



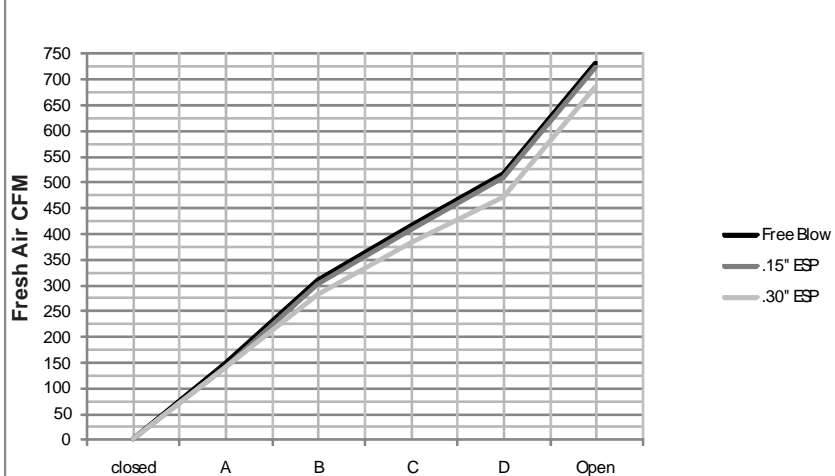
W24G BFM Airflow Versus Position - Low Speed



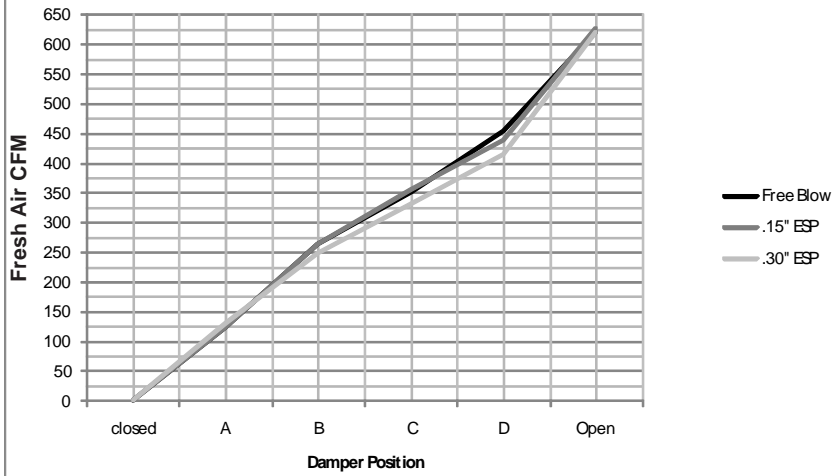
W24G BFM Airflow Versus Position - Medium Speed



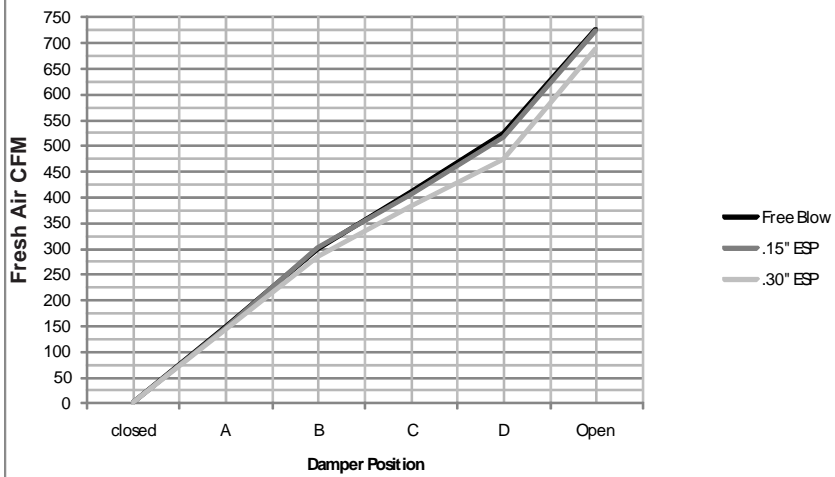
W24G BFM Airflow Versus Position - High Speed



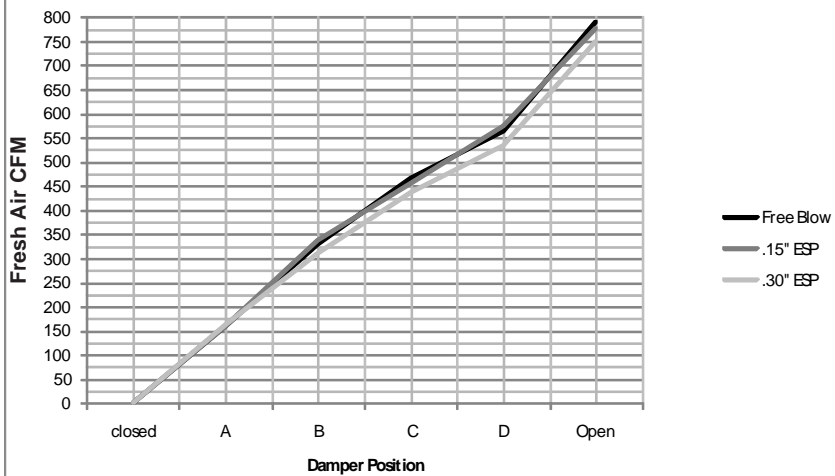
W30-36G EFM Airflow Versus Position - Low Speed



W30-36G EFM Airflow Versus Position - Medium Speed



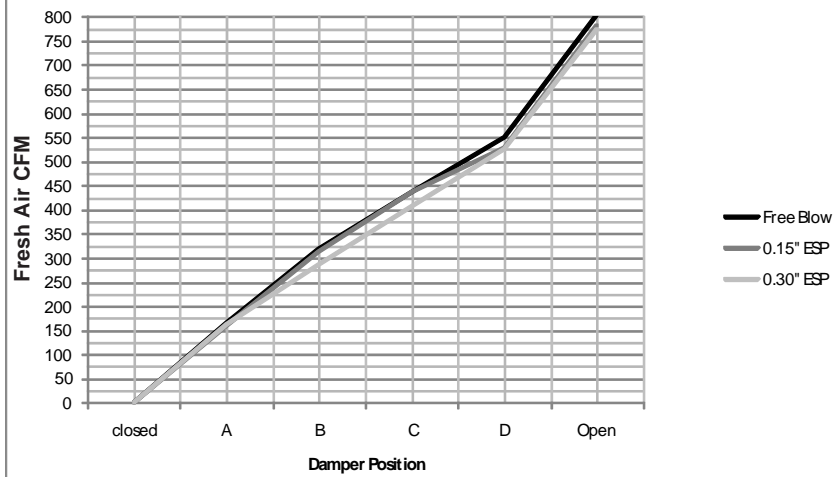
W30-36G EFM Airflow Versus Position - High Speed



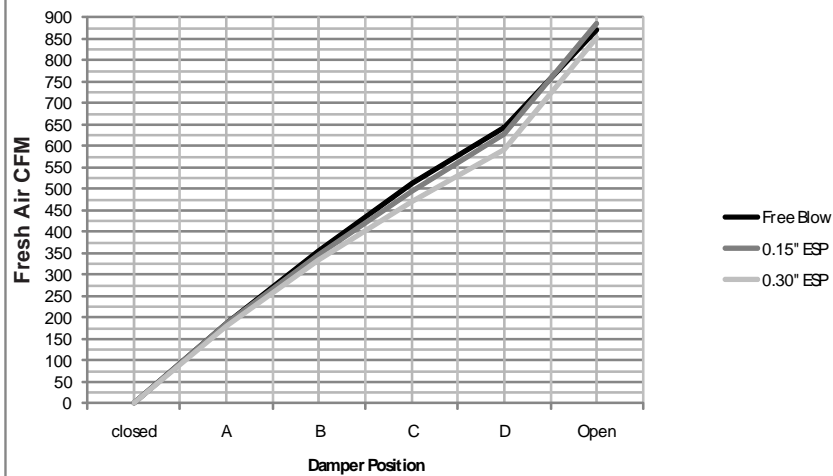
W42-60G EFM Airflow Versus Position - Low Speed



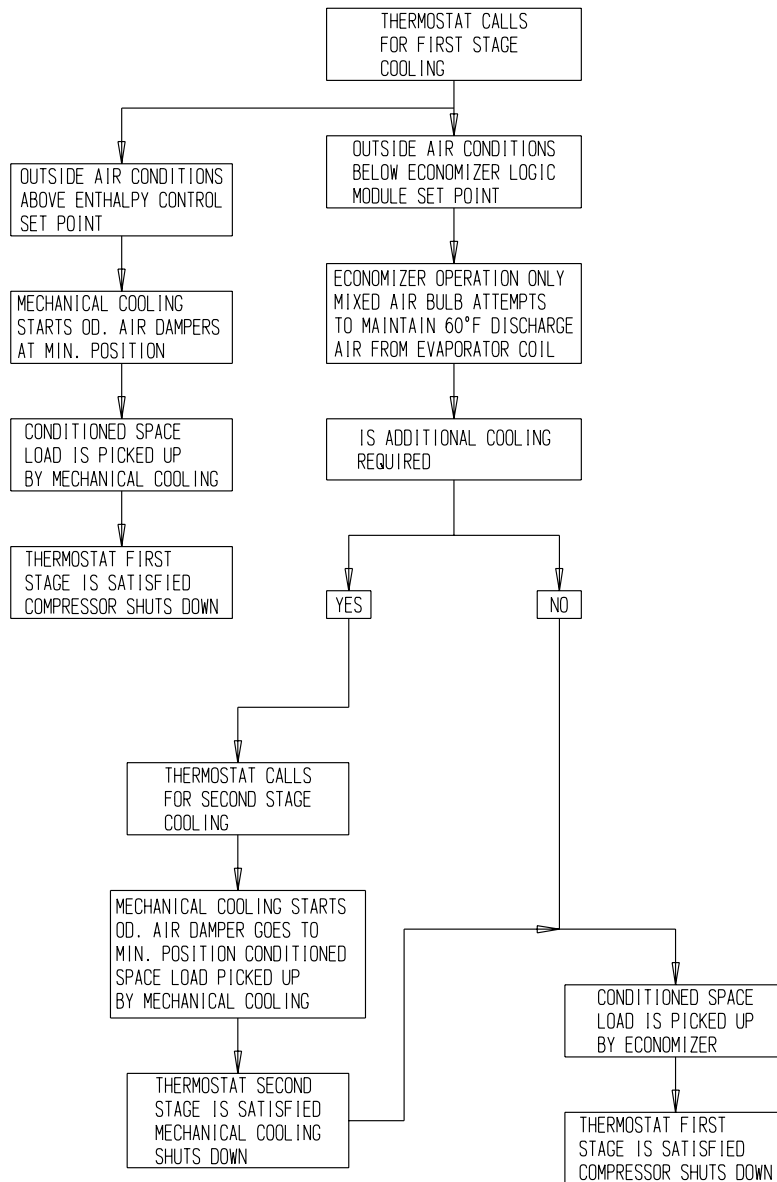
W42-60G EFM Airflow Versus Position - Medium Speed



W42-60G EFM Airflow Versus Position - High Speed



**FIGURE 6
ECONOMIZER OPERATION FOR SINGLE COMPRESSOR UNIT**



MIS-1626

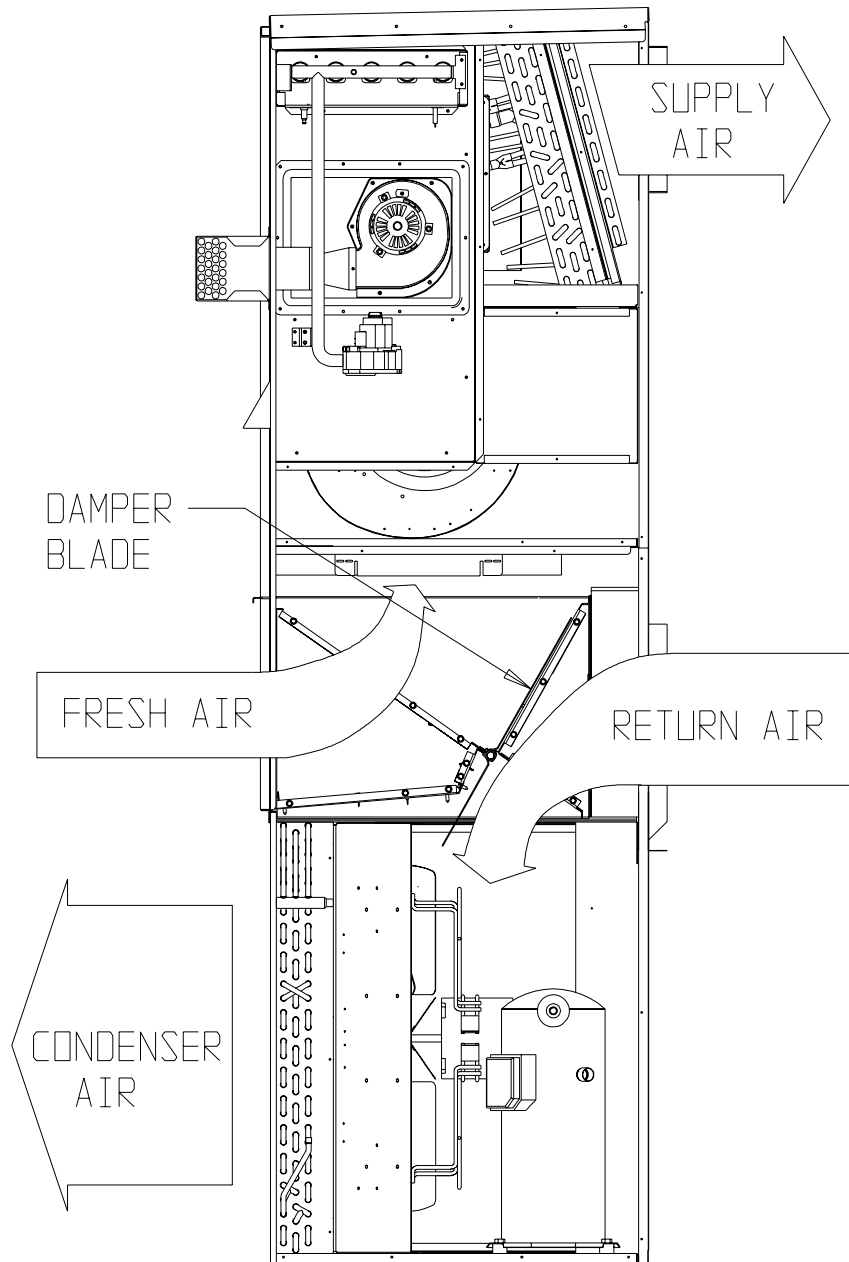
ECONOMIZER SEQUENCE OF OPERATION

If second stage closes on the thermostat, the dampers return to the closed or minimum position setting and the compressor starts for mechanical cooling.

CONDITION A — COOL OUTDOORS

First stage cooling closes and powers the economizer dampers to economizer mode and the indoor blower starts. Mixed Air Sensor senses a mixture of return air and outdoor air and modulates the dampers accordingly. Compressor operation is inhibited. (See Figure 7.)

**FIGURE 7
CALL FOR BLOWER OPERATION**



MIS-2413

CONDITION B — WARM OUTDOORS

First stage cooling cycles the compressor and dampers remain in mechanical cooling mode.

**FIGURE 8
CALL FOR COOLING OPERATION**

