
INSTALLATION INSTRUCTIONS

COMMERCIAL ROOM VENTILATORS WITH EXHAUST

MODEL
WGSCRVMP-5

For Use with Bard 3 through 5 Ton
Step Capacity Wall Mount Air Conditioners
with Gas Heat



CLIMATE CONTROL SOLUTIONS

Bard Manufacturing Company, Inc.
Bryan, Ohio 43506

Since 1914...Moving ahead just as planned.

Manual : 2100-499C
Supersedes: 2100-499B
File: Volume III Tab 19
Date: 11-12-09

CONTENTS

General

General Information	3
Unpacking	3
Description	3
Models	3

Installation

Basic Installation	4, 5, 7, 8
Blade Adjustment for Desired Ventilator Air	10
Adding Optional CO ₂ Control Sensor	13
Commercial Room Ventilator Sequence	15

Figures

Figure 1	Removal of Exterior Panels	4
Figure 2	Install Ventilator	5
Figure 3	Install Loose Piece Wire Harness	6
Figure 4	WGSCRVMP-5 Lead Connections	7
Figure 5	Step Control Installation	8
Figure 6	Damper Control Board	9
Figure 7	CO ₂ Sensor Set-Up	14
Figure 8	Call for Blower Operation	15
Figure 9	Call for Cooling Operation	16

Tables

Table 1	For Use w/Models	3
Table 2	Factory Default Settings	12

Graphs

WG3S Ventilation Airflow	11
WG4S Ventilation Airflow	11
WG5S Ventilation Airflow	12

**Manufactured under U.S. Patent number 5,301,744
Other patents pending**

**COPYRIGHT DECEMBER 2007
BARD MANUFACTURING COMPANY, INC.
BRYAN, OHIO USA 43506**

GENERAL

GENERAL INFORMATION

The ventilator should only be installed by a trained heating and air conditioning technician. These instructions serve as a guide to the technician installing the ventilator package. They are not intended as a step by step procedure with which the mechanically inclined owner can install the package.

The ventilator housing is shipped in one carton which contains the electrical harness, step control assembly, miscellaneous hardware and installation instructions.

UNPACKING

Upon receipt of the equipment be sure to compare the model number found on the shipping label with the accessory identification information on the ordering and shipping document to verify that the correct accessory has been shipped.

Inspect the carton housing of each ventilator as it is received, and before signing the freight bill, verify that all items have been received and that there is no visible damage. Note any shortages or damage on all copies of the freight bill. The receiving party must contact the last carrier immediately, preferably in writing, requesting inspection by the carrier's agent. Concealed damage not discovered until after loading must be reported to the carrier within 15 days of its receipt.

DESCRIPTION

The WGSCRVMP-5 ventilator is designed to be used with Bard 3 through 5 ton wall mount series step capacity air conditioners. It is an electromechanical vent system designed to provide fresh air to meet indoor air quality standards. It automatically adjusts to the mode of operation to maintain consistent fresh air intake levels. Examples are blower only, stage 1 cooling and stage 2 cooling, which are all set for different total airflows.

MODELS

When installed in the models (listed in Table 1), the WGSCRVMP-5 provides built in exhaust provisions. When the damper blade opens to bring fresh air in, the damper also opens an exhaust relief. The exhaust air will flow into the condenser section of the unit. The condenser fan will help draw exhaust air out.

TABLE 1

MODEL	FOR USE WITH FOLLOWING UNITS
WGSCRVMP-5	WG3S WG4S WG5S

INSTALLATION

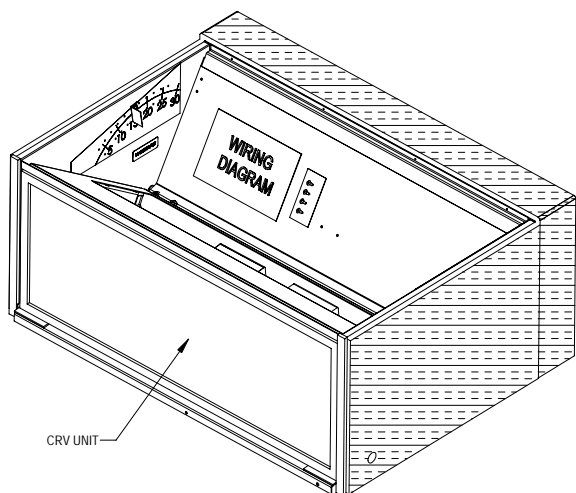
WARNING

Open and lock unit disconnect switch before installing this accessory to prevent injury or death due to electrical shock or contact with moving parts. Turn thermostat to off.

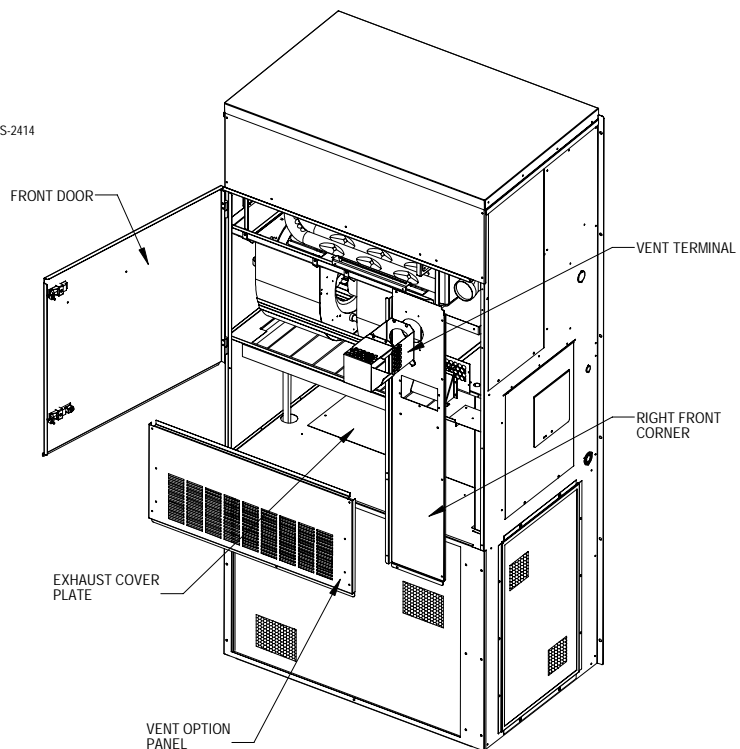
BASIC INSTALLATION

1. Unpack the ventilator assembly which includes the integral ventilator with attached electrical harness, step control assembly and miscellaneous hardware.
2. Remove and save the existing exterior blower access and service access panels (see Figure 1).
3. Remove and discard exhaust cover plate (see Figure 1).
4. In rear of opening towards duct connection, install exhaust opening adaptor plate (included).

**FIGURE 1
REMOVAL OF EXTERIOR PANELS**



MIS-2414



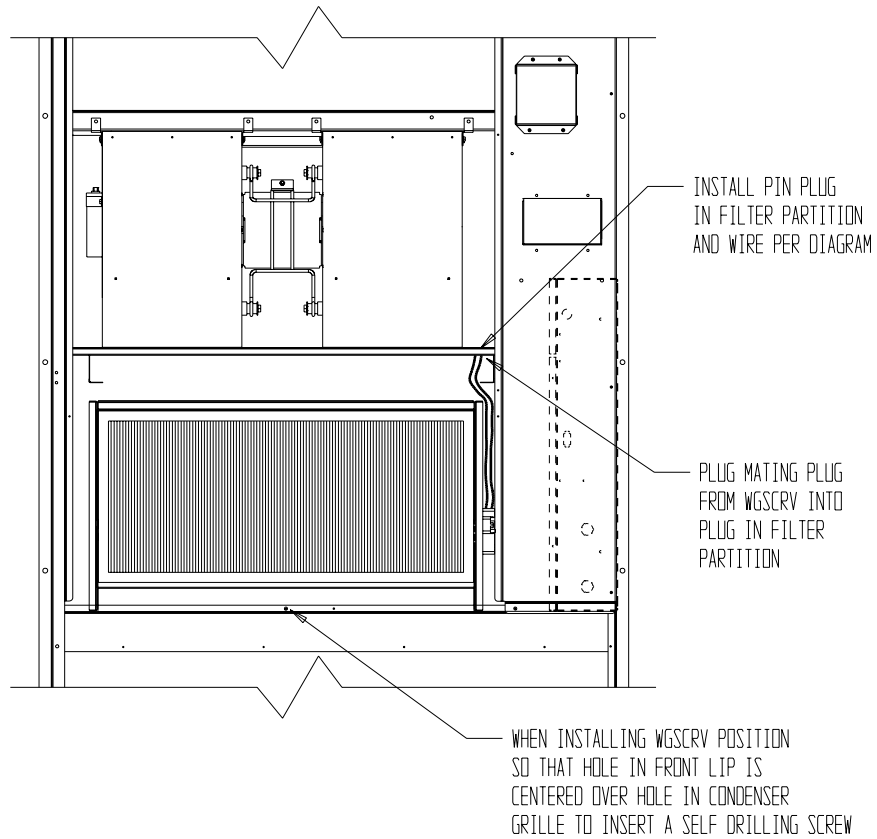
MIS-2416

5. Install ventilator sheet metal assembly by inserting the ventilator into the unit – centering between the tubing on the left and the control panel on the right. Once the ventilator is fully inserted, slide the ventilator to align screw hole through the front of the condenser grille. (See Figure 2.)

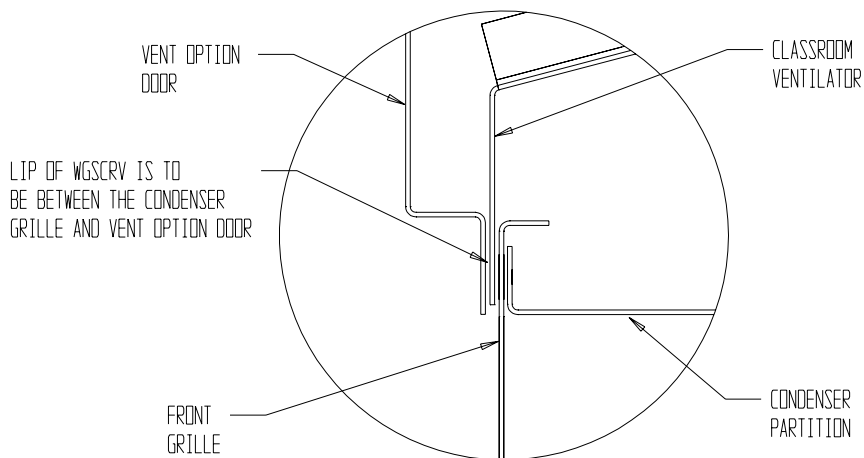
IMPORTANT: Position front lip of ventilator on top of front grille and condenser partition. (See Figure 2 inset.) This is important to ensure proper drainage of any water entering damper assembly.

6. Open control panel to gain access to unit low voltage terminal block.
7. Install loose piece wire harness plug into filter tray & route wires into low voltage box. (See Figure 3.)
8. Plug wire plug from vent package installed in Steps #1 through #6 into plug installed in Step #7.

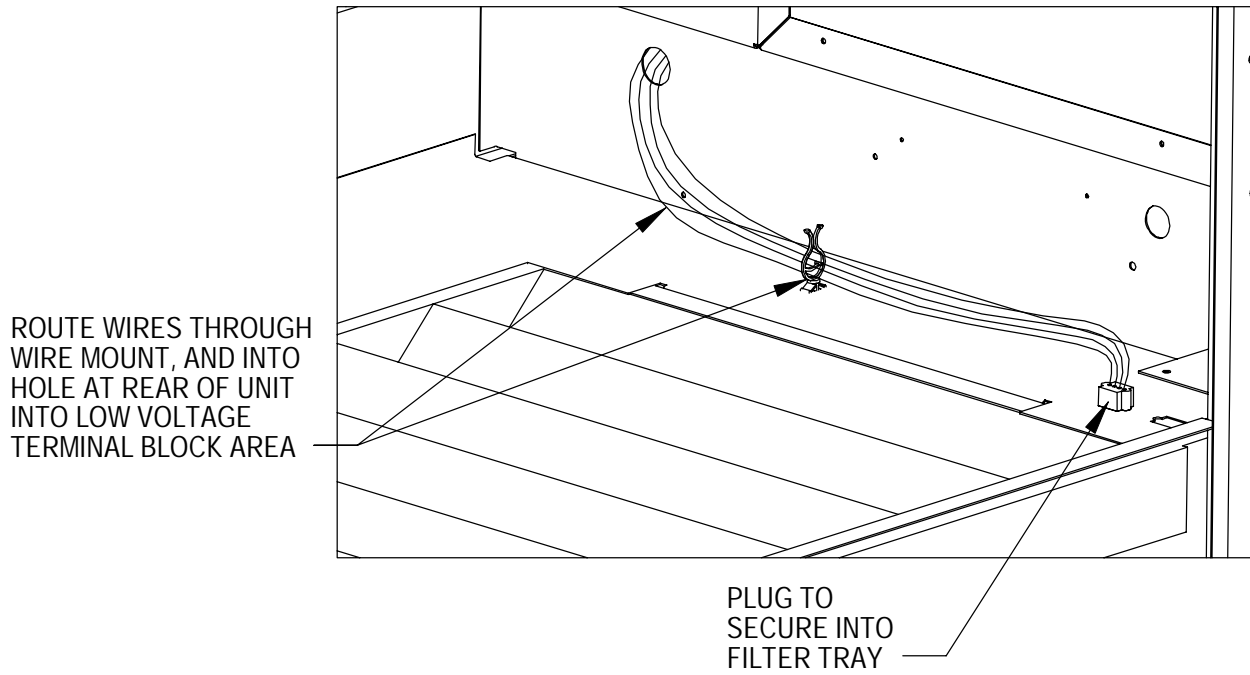
**FIGURE 2
INSTALL VENTILATOR**



**FIGURE 2 INSET
SIDE SECTION**

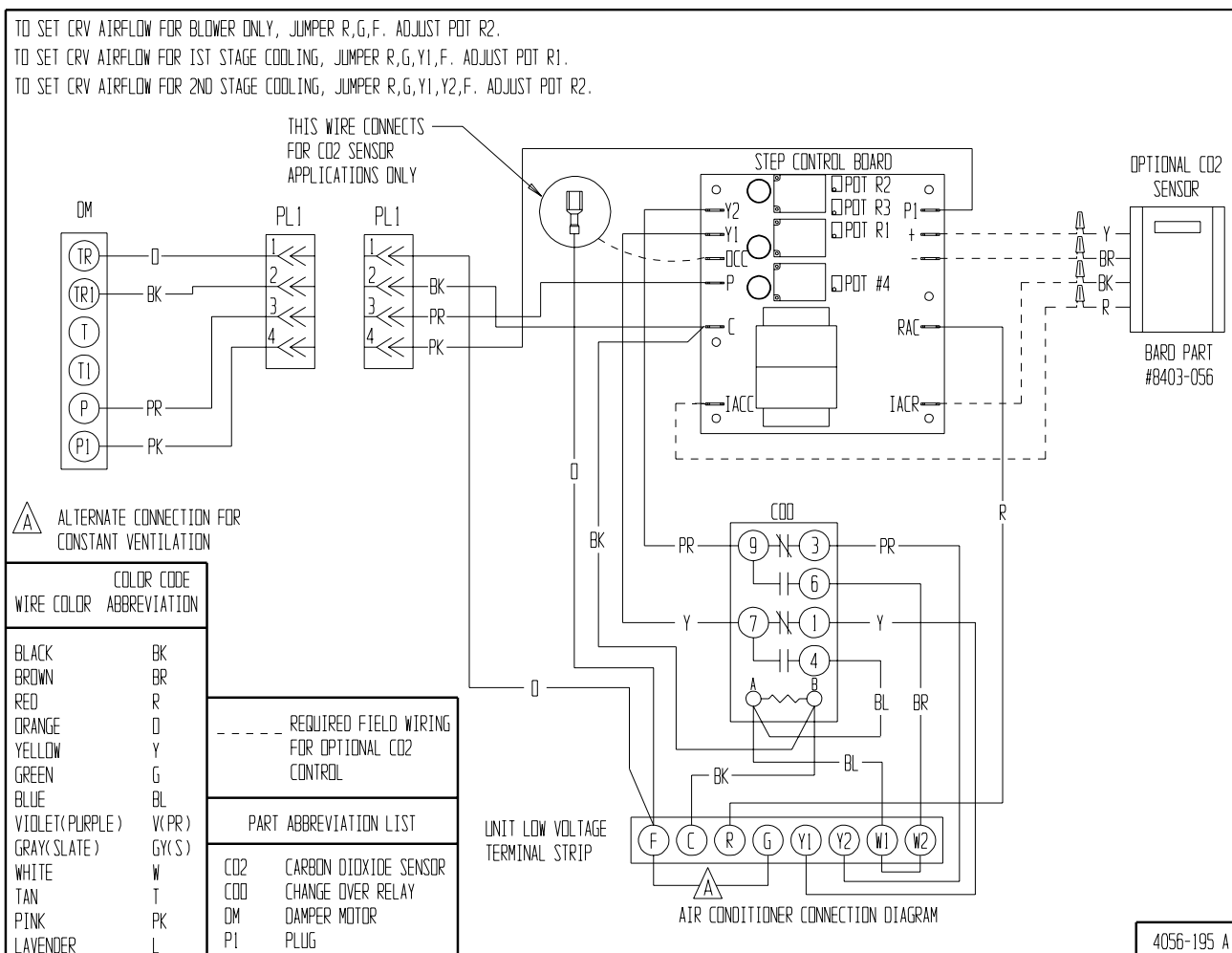


**FIGURE 3
INSTALL LOOSE PIECE
WIRE HARNESS PLUG**



MIS-2415

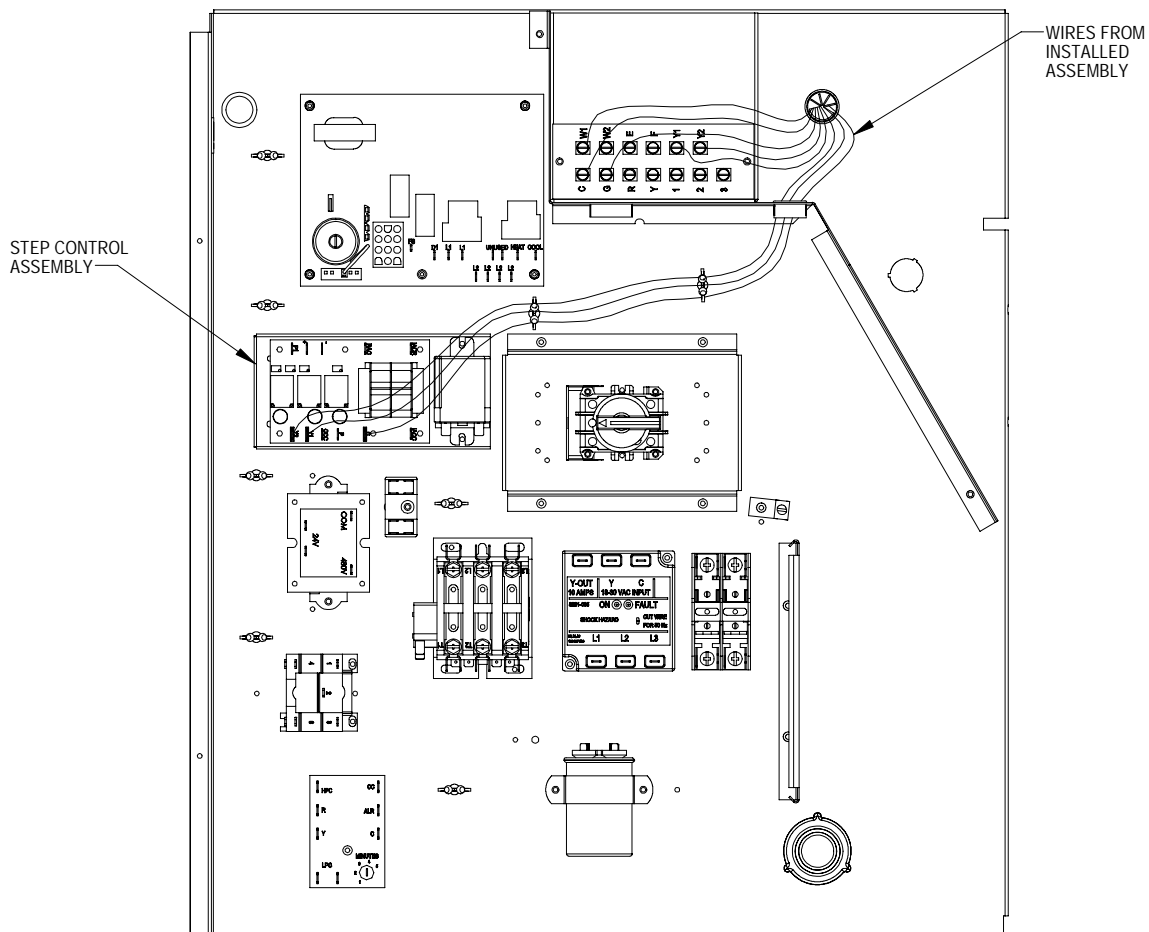
**FIGURE 4
WGSCRVMP-5 LEAD CONNECTIONS**



- Locate the step control assembly packaged with the assembly. This assembly will install in the control panel, below the control board by aligning the plastic standoffs with pre-punched holes in the control panel. See Figure 5.
- From the wire harness installed in Step #8, route the pink, purple and black wires down through the bushing below where they entered the low voltage box, across the control panel through the wire looms. See Figure 5.
- The wires from Step #10 all connect to the step control board as follows per Figure 4:
 - Pink to terminal "P"
 - Purple to terminal "P"
 - Black to terminal "C"
- The remaining wires in the low voltage box from Step #8 connect to the 24 volt thermostat connection strip as follows per Figure 4:
 - Black to terminal "C"
 - Red to terminal "R"
 - Yellow to "Y1"
 - Purple to "Y2"
 - Blue to "W1"
 - Brown to "W2"
- Orange to terminal "F" or "G". When connected to the "G" terminal, it will ventilate anytime the blower is running. If connected to "F" and you have a thermostat or control system, you can regulate to ventilate only during occupied conditions.
- Replace right front unit corner and vent terminal.
- Close upper unit door to seal blower discharge air.
- Ventilator checkout – (*Note: It may be more efficient to disconnect the thermostat from the low voltage terminal strip and use a set of jumper wires to perform these steps.*)
 - A. Resupply power to the unit.
 - B. Energize the evaporator blower by switching thermostat to the manual fan position with heat/cool in OFF position. (**Jumper "R" to "G"**)
 - C. Ventilator should open to the position set by "R1" potentiometer on step control board. (See Figure 6.)
 - D. Now energize Stage #1 cooling/heating by switching the thermostat to the corresponding mode and setting the temperature offset slightly beyond the actual room temperature. (**Jumper "R" to "G" and "Y1"**)

- E. Ventilator should now open to the position set by "R2" potentiometer on step control board. (See Figure 6.)
 - F. Now energize the Stage #2 cooling/heating by increasing the thermostat setting to a greater offset than the actual room temperature. **(Jumper "R" to "G", "Y1" and "Y2")**
 - G. Ventilator should now open to the position set by "R3" potentiometer on step control board. (See Figure 6.)
 - H. Now turn the heat/cool selector to OFF, and set the fan switch back to AUTO. The damper blade should close. **(Remove all jumper connections.)**
 - I. This completes the ventilator checkout.
16. Adjust damper blade for required ventilation. (See next section.)
 17. Replace mist eliminator filter. Be sure that it is installed with the drain holes to the bottom.
 18. Remove blank off plate installed on lower service access door. Plug four (4) mounting holes with the plastic plugs provided with the ventilator.
 19. Replace service access panel.
 20. Close control panel cover.
 21. Ventilator is now ready for operation.

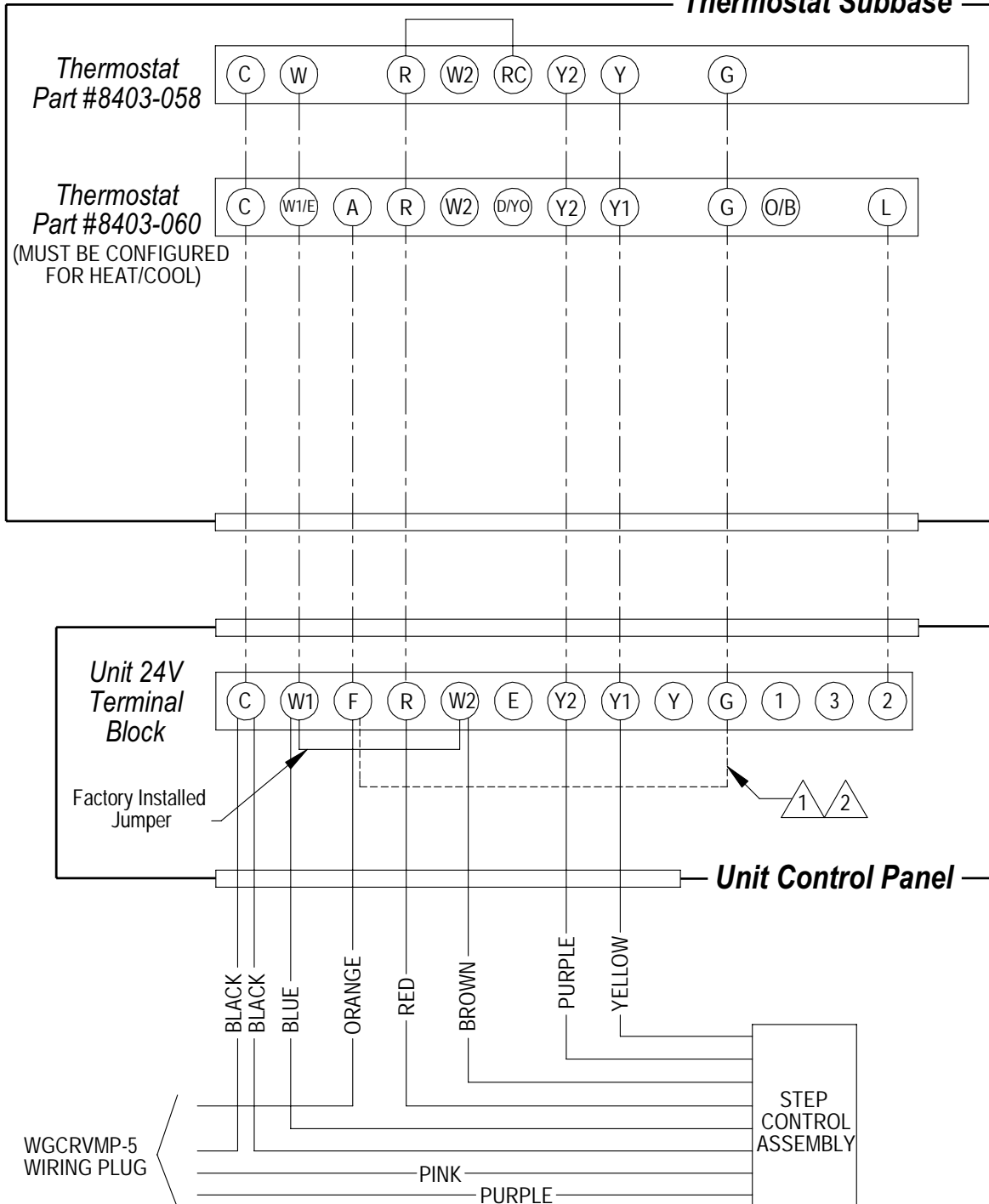
**FIGURE 5
STEP CONTROL INSTALLATION**



MIS-2419

Low Voltage Wiring - Multi-position Commercial Room Ventilator

Thermostat Subbase



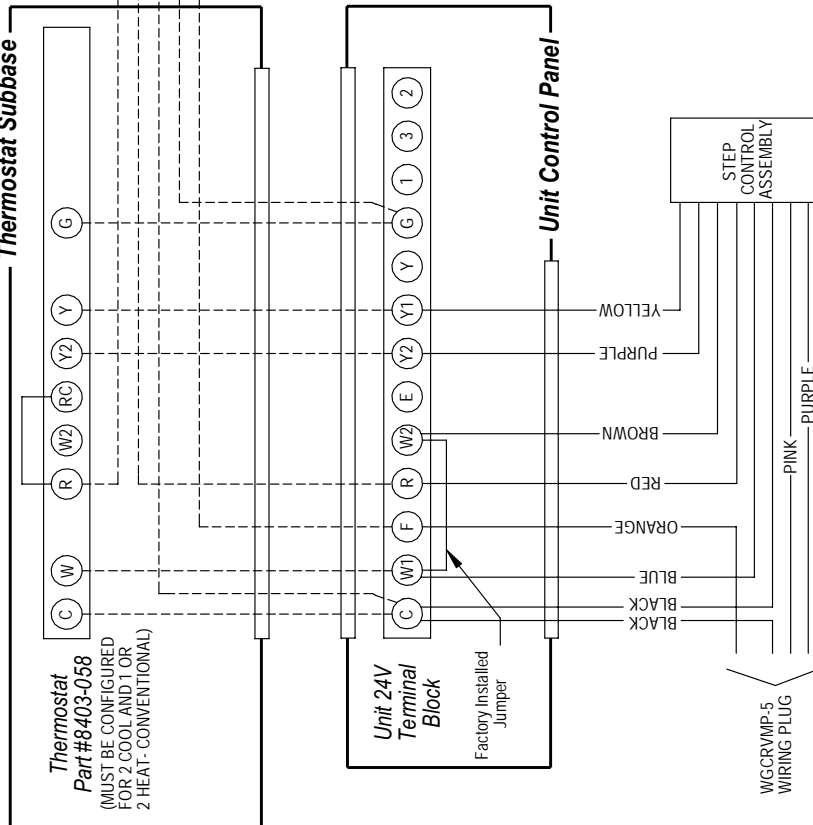
1 MUST INSTALL JUMPER FOR 8403-058 OR OTHER THERMOSTAT THAT DOES NOT HAVE OCCUPANCY OUTPUT.

2 INSTALL IF YOU REQUIRE VENTILATION ANYTIME BLOWER IS ON.

MIS-2433 D

Low Voltage Wiring - Multi-position Commercial Room Ventilator

Thermostat Subbase



Thermostat
Part #8403-058

(MUST BE CONFIGURED FOR 2 COOL AND 1 OR 2 HEAT- CONVENTIONAL)

Unit 24V Terminal Block

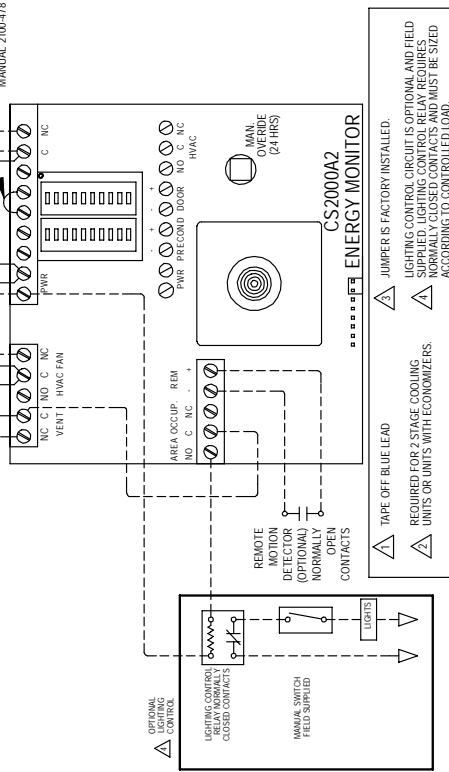
Factory Installed Jumper

Unit Control Panel

STEP CONTROL ASSEMBLY

WGCRVMP-5 WIRING PLUG

FACTORY NUMBERS - SEE SEARCH THE DETAIL ON PAGE 3 OF BARD MANUAL 2100-478



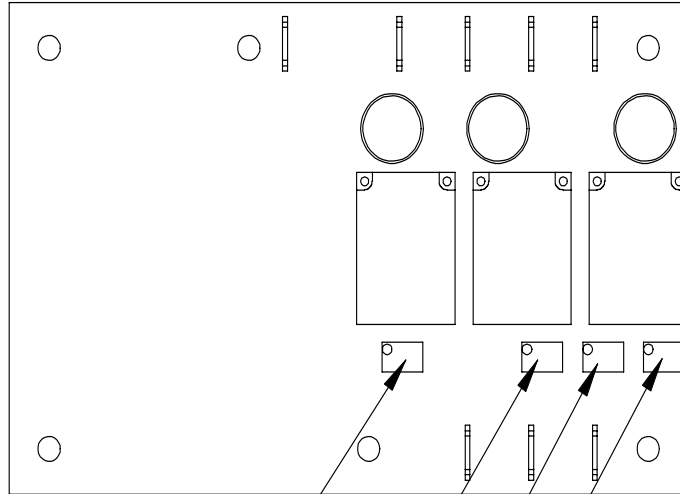
CS2000A2 ENERGY MONITOR

▲ TAPE OFF BLUE LEAD
▲ JUMPER IS FACTORY INSTALLED.
▲ LIGHTING CONTROL CIRCUIT IS OPTIONAL AND FIELD SUPPLIED. LIGHTING CONTROL RELAY REQUIRES NORMALLY CLOSED CONTACTS AND MUST BE SIZED ACCORDING TO CONTROLLED LOAD.

RECOMMENDED SWITCH SETTINGS SHOWN BELOW

FUNCTION SWITCHES		TEMPERATURE SWITCHES	
LEARN		90	
PRE P		84	
MODE		81	
RATE		78	
SEARCH-TIME		68	
N/C		65	
STAGE		62	
AUX		58	
DEMAND 2		54	
DEMAND 1		48	

FIGURE 6
SETTING 3-POSITION CRV DAMPER CONTROL BOARD
(Utilize the charts for your specific model on the following pages)



"R7" ADJUSTMENT POTENTIOMETER
 FOR APPLICATIONS WITH CO₂ SENSORS.
 SEE "ADDING OPTIONAL CO₂ CONTROL
 SENSOR" IN THIS MANUAL.

"R1" ADJUSTMENT POTENTIOMETER
 FOR "BLOWER ONLY" DAMPER POSITION.
 ("G" SIGNAL ONLY)

"R2" ADJUSTMENT POTENTIOMETER
 FOR "STAGE #1" HEATING OR COOLING
 DAMPER POSITION. ("G" AND "Y1"
 CONTROL SIGNALS)

"R3" ADJUSTMENT POTENTIOMETER
 FOR "STAGE #2" HEATING OR COOLING
 DAMPER POSITION. ("G", "Y1", AND
 "Y2" CONTROL SIGNALS)

MIS-2117 A

BLADE ADJUSTMENT FOR DESIRED VENTILATOR AIR

The amount of ventilation air supplied by the commercial room ventilator is dependent on five (5) factors.

1. Return air duct static pressure drop.
2. Supply air duct static pressure drop.
3. Indoor blower motor speed.
4. Damper blade open position setting for each mode of operation.
5. Tightness or looseness of building envelope.

You will have to set the damper position for each mode of operation using the set-point potentiometers on the Damper Position Step Control Board (see Figure 6). See Table 2 for Factory Default Settings.

Refer to the graphs on the following pages to determine the necessary blade setting to achieve the ventilation air required based upon blower only, Stage #1 and Stage #2 modes of operation. These charts are model specific, so you will have to match the chart to the specific model you are working with.

1. Set the damper position for blower only operation.
 - A. Energize the evaporator blower by switching thermostat to the manual fan position with heat/cool in OFF position (or Jumper “R” to “G” with thermostat disconnected at unit).
 - B. Locate potentiometer “R1” on the Damper Position Step Control Board. See Figure 6.
 - C. Using a small screwdriver, adjust potentiometer until damper position aligns with numerical location on the label interior of the sheet metal damper assembly.

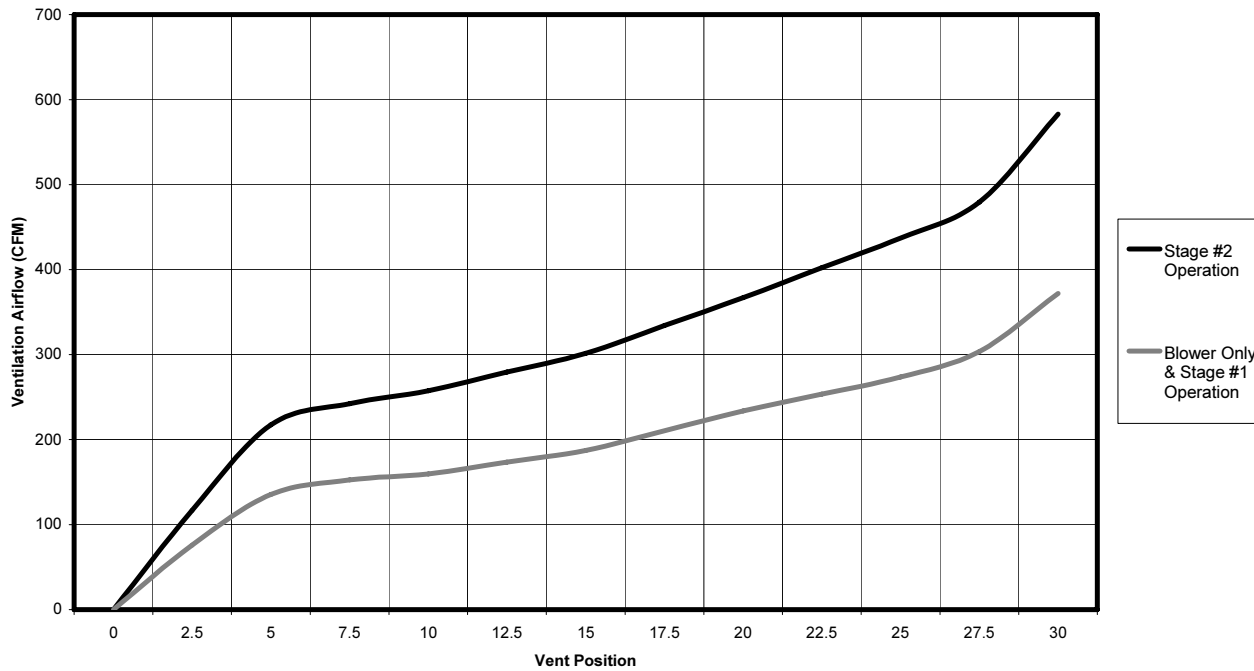
2. Set the damper position for Stage #1 cooling/heating operation.
 - A. Energize the evaporator blower and compressor by switching thermostat to the heat or cool mode, and setting it to a minimal offset to the room temperature to engage the mode of operation desired (or Jumper “R” to “G” and “Y1” with thermostat disconnected at unit).
 - B. Locate potentiometer “R2” on the Damper Position Step Control Board. See Figure 6.
 - C. Using a small screwdriver, adjust potentiometer until damper position aligns with numerical location on the label interior of the sheet metal damper assembly. (Make sure there is not a call on “Y2” or “W2”.)
3. Set the damper position for Stage #2 cooling/heating operation.
 - A. Energize the evaporator blower and compressor by switching thermostat to the heat or cool mode and set a large temperature offset to the room temperature to engage the mode of operation desired (or Jumper “R” to “G”, “Y1” and “Y2” with thermostat disconnected at unit).
 - B. Locate potentiometer “R3” on the Damper Position Step Control Board. See Figure 6.
 - C. Using a small screwdriver, adjust potentiometer until damper position aligns with numerical location on the label interior of the sheet metal damper assembly per the chart.

TABLE 2
FACTORY DEFAULT SETTINGS

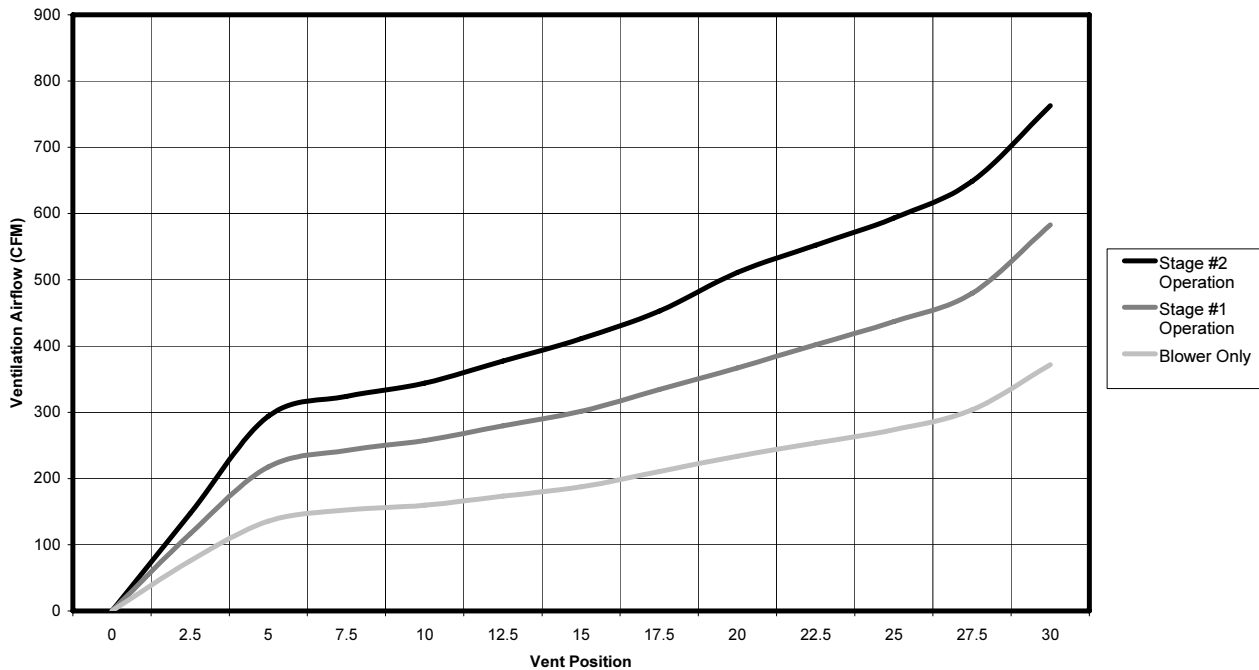
MODE OF OPERATION	POTENTIOMETER	WG3S		WG4S		WG5S	
		BLADE SETTING	APPROX. CFM	BLADE SETTING	APPROX. CFM	BLADE SETTING	APPROX. CFM
VENT	R1	30	375	30	375	30	375
PART LOAD (Stage 1)	R2	30	375	26	450	19	450
FULL LOAD (Stage 2)	R3	26	450	17	450	16	450

NOTE: Heating operation will always be equivalent to Full Load Cooling (Stage #2).

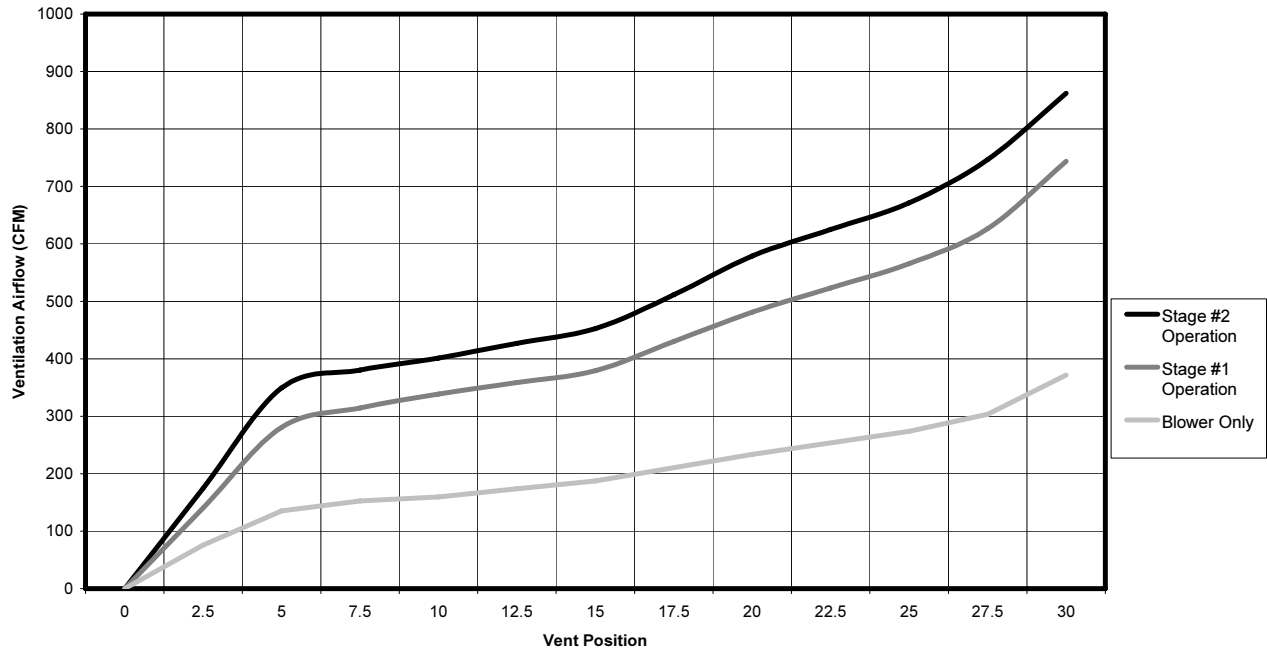
WG3S Ventilation Airflow



WG4S Ventilation Airflow



WG5S Ventilation Airflow



ADDING OPTIONAL CO₂ CONTROL SENSOR

Adding an optional Bard Part #8403-056 to this control will maximize the capabilities of this vent by only supplying fresh air intake to maintain CO₂ levels. This has multiple benefits.

- Minimizes ventilation load on structure as it only brings in what is required to maintain CO₂ levels lowering reconditioning requirements (not having to heat/cool as much outside air).
- Will self-adjust for various occupancy levels so that you are not bringing in fresh air beyond need. For example, if a room is designed for a maximum occupancy of 40 persons (the standard ventilation control would have to be set for that occupancy), but the room typically only contains 25 persons. This control will self-adjust the amount of fresh air intake from 600 to 375 CFM automatically (based upon 15 CFM per person standard rate to ASHRAE standards).

Basic Installation

1. Make sure power is turned off to the unit
2. Follow steps beginning on page 2 for installation for standard control and vent assembly, then proceed with the following steps.
3. Run (4) wire thermostat wire from the unit to the desired CO₂ sensor location.
4. Follow Figure 7 to configure the CO₂ sensor for proper operation. This set-up includes:
 - Setting control for 500-1500 ppm CO₂ control band (damper will be in full closed position @ 5000 ppm CO₂, and will be at full position if CO₂ levels reach 1500 ppm). This is accomplished by setting “SW1” to the “OFF” position and “SW2” to the “ON” position.
 - Setting control for 4-20 MA control by installing the jumper for the 20-100% range.
 - Setting control for current (rather than voltage) output.
5. Connect the thermostat wiring from the CO₂ sensor to step control assembly following the wiring diagram in Figure 4, or the one on the ventilator assembly.
6. Connect the orange wire from the “F” terminal of the units low voltage connection strip to the “OCC” terminal on the step control board.
7. To check operation, restore power to the unit.
8. Make sure that thermostatic control is in “occupied” mode of operation calling for ventilation.
9. Have someone stand in front of the CO₂ sensor and breath on it. The display should show an increase in CO₂ ppm, and the damper blade in the ventilation package should increase (may be good to have a helper - one to breath on control and one to observe damper).

FIGURE 7
8403-056 CO₂ SENSOR SET UP

WGSCRVMP-5 Set-Up for Full Demand Control Using 8403-056 CO₂ Controller

Controller Settings--See Fig. 7b	
Range 500-1500 ppm	
SW1 = "Off"	
SW2 = "On"	
"Out" set to "0-100%"	NOTE: Fig. 7a are the default jumper settings. The "OUT" and "AN" must be repositioned as shown in Fig. 7b
Analog Output (AN) set to "Current"	

4-20mA	AN (ppm)	Damper (1)	Approx. Blade Position (2)
---	500	Fully Closed	0
---	550	Fully Closed	0
---	600	Fully Closed	0
---	650	Fully Closed	0
4	700	Fully Closed	0
5	750		2
6	800		4
7	850		5.5
8	900		7.5
9	950		9.5
10	1000		11
11	1050		13
12	1100		15
13	1150		17
14	1200		19
15	1250		20.5
16	1300		22.5
17	1350		24.5
18	1400		26
19	1450		28
20	1500	Fully Open	30

- (1) Damper should be fully closed at 700 ppm, if not Potentiometer R7 can be adjusted clockwise (CW) to close it. If it is fully closed at 700 ppm or lower, no adjustments required.
 (2) Blade as referenced to the Blade Position Label.

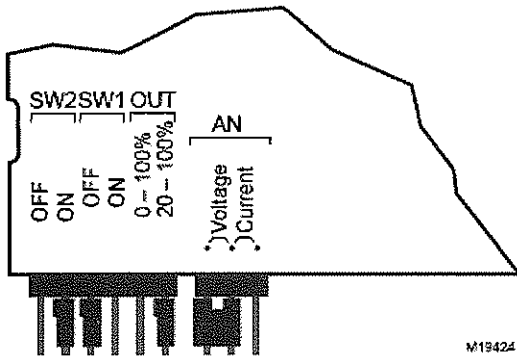


Fig. 7a -- Default Jumper Settings

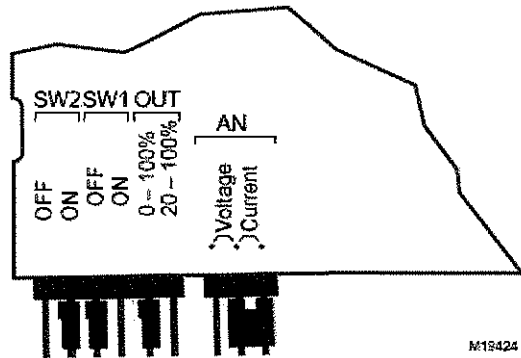


Fig. 7b -- Final Jumper Settings

COMMERCIAL ROOM VENTILATOR – WG*S SERIES

FEATURES

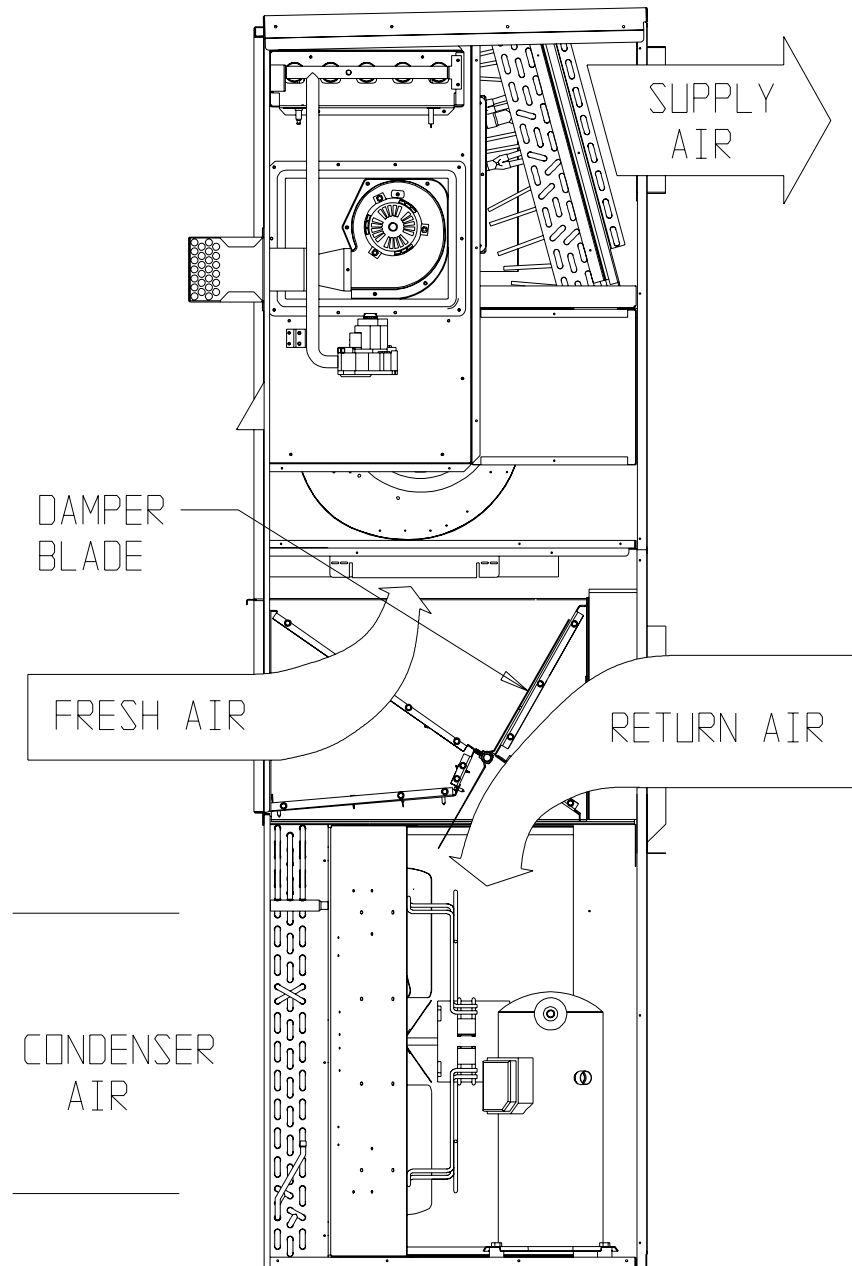
- One piece construction – easy to install with no mechanical linkage adjustment required.
- Exhaust air damper – built in with positive closed position. Provides exhaust air capability to prevent pressurization of tight buildings.

- Actuator motor – 24 volt, power open, spring return with built in torque limiting switch.
- Provides up to 75 percent of outside air.

COMMERCIAL ROOM VENTILATOR SEQUENCE OF OPERATION

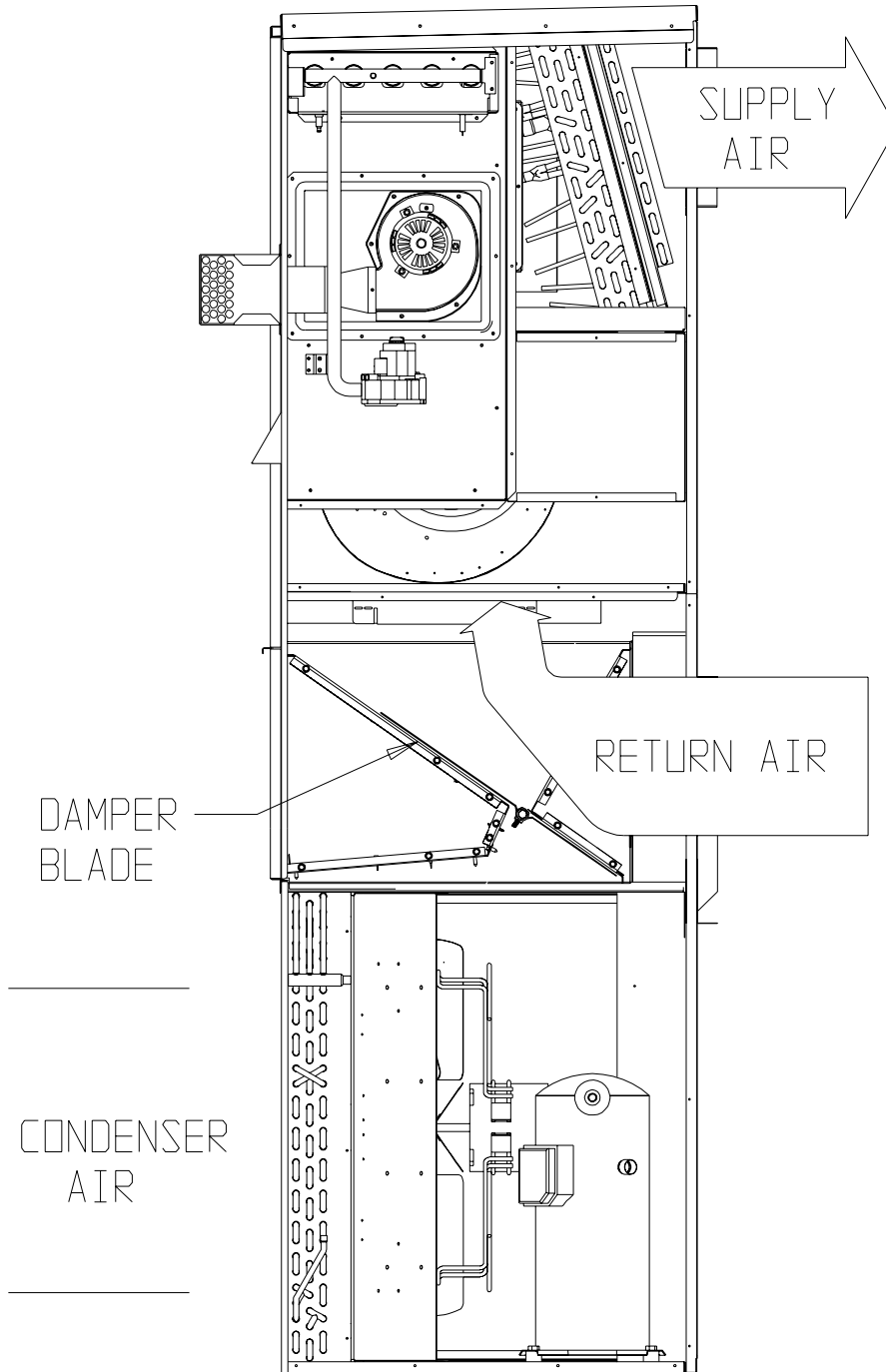
On a call for blower operation, CRV opens to a position as set by Step Control Position Assembly. See Figure 8.

**FIGURE 8
CALL FOR BLOWER OPERATION**



A call for cooling cycles the compressor, and dampers remain in the ventilation mode. On loss of blower operation, CRV closes fully. See Figure 9.

**FIGURE 9
CALL FOR COOLING OPERATION**



MIS-2412