

---

# INSTALLATION INSTRUCTIONS

---

## LOW VOLTAGE CONTROL CIRCUIT WIRING

### MODELS

**W\*\*A**

**W\*\*L**

**W\*\*A\*D**

**W\*\*L\*D**



Bard Manufacturing Company, Inc.  
Bryan, Ohio 43506

*Since 1914...Moving ahead just as planned.*

Manual : 2100-507A  
Supersedes: 2100-507  
File: Volume III Tab 16  
Date: 12-19-08

# Contents

---

## Installation Instructions

Wiring – Low Voltage Wiring .....	3
Operating Voltage Range .....	3
Low Voltage Connection .....	3

## Wiring Diagram

Figure 11 A/C Connection Diagram .....	14
--	----

## Figures

Figure 1 Basic A/C w/Opt. Elec. Heat .....	4
Figure 2 Opt. MFAD, CRV or ERV Vent. Pkg. w/ Programmable T-Stat .....	5
Figure 3 Opt. MFAD, CRV or ERV Vent. Pkg. w/ Non-Programmable T-Stat .....	6
Figure 4 A/C with Economizer .....	7
Figure 5 A/C w/Dehumidification Sequence & No Vent Pkg. ....	8
Figure 6 A/C w/Dehumidification Sequence & No Vent Pkg. Using Separate Controls .....	9
Figure 7 A/C w/Dehumidification Sequence w/Vent Pkg. Using Combination Controller .....	10
Figure 8 A/C w/Dehumidification Sequence w/Vent Pkg. Using Non-Programmable .....	11
Figure 9 A/C w/Dehumidification Sequence & Economizer .....	12
Figure 10 A/C w/Dehumidification Sequence & Economizer w/Combination Control .....	13

## Tables

Table 1 Diagram to Use w/Unit & Vents .....	3
Table 2 Operating Voltage Range .....	3
Table 3 Wall Thermostat .....	3
Table 4 Humidity Controls .....	3
Table 5 CO2 Controller .....	3
Table 6 Thermostat Wire Size .....	3

**TABLE 1  
DIAGRAM TO USE WITH UNIT AND VENTS**

System Type	Model Series	No Vents		MFAD, CRV or ERV		Economizer		CS2000A*
		Electronic	Programmable	Electronic	Programmable	Electronic	Programmable	All
Air Conditioner	W**A, W**L	1	1	3	2	4	4	11
Air Conditioner w/Dehumidification Sequence	W**A*D W**L*D	6	5	8	7	9	10	11

**WIRING – LOW VOLTAGE WIRING**

230/208V, 1 phase and 3 phase equipment dual primary voltage transformers. All equipment leaves the factory wired on 240V tap. For 208V operation, reconnect from 240V to 208V tap. The acceptable operating voltage range for the 240V and 208V taps are:

**TABLE 2  
OPERATING VOLTAGE RANGE**

TAP	RANGE
240V	253 – 216
208V	220 – 187

*NOTE: The voltage should be measured at the field power connection point in the unit and while the unit is operating at full load (maximum amperage operating condition).*

An 18 gauge copper, color-coded thermostat cable is recommended. The connection points are shown in this Manual. See Table above.

**Low Voltage Connection**

These units use a 24-volt AC low voltage circuit. The “R” terminal is the *hot* terminal and the “C” terminal is *grounded*.

“G” terminal is the *fan input*.

“Y” terminal is the *compressor input for cooling*.

“W1” terminal is the *1st stage electric heat*.

“W2” terminal is the *2nd stage heat* (if equipped).

“A” terminal is the *ventilation input*. This terminal energizes any factory installed ventilation option.

“3” terminal is the *dehumidification input*. If installed, this terminal energizes any factory installed dehumidification option.

**NOTE: On models with “J” or “M” Control Module, “3” terminal is used along with “1” and “2” for the alarm relay. “J” or “M” modules are not used in conjunction with dehumidification units.**

LOW VOLTAGE CONNECTIONS FOR DDC CONTROL	
Fan Only	Energize G
Cooling Mode	Energize Y, G
1st Stage Heating	Energize W1
2nd Stage Heating (if employed)	Energize W1, W2
Ventilation	Energize G, A
Dehumidification (if employed)	Energize 3

**TABLE 3  
WALL THERMOSTAT**

Part Number	Predominate Features
8403-057 (TH3110D1040)	1 stage Cool, 1 stage Heat Electronic Non-Programmable Auto or Manual changeover
8403-058 (TH5220D1151)	2 stage Cool, 2 stage Heat Electronic Non-Programmable HP or Conventional Auto or Manual changeover
8403-060 (1120-445)	3 stage Cool; 3 stage Heat Programmable/Non-Programmable Electronic HP or Conventional Auto or Manual changeover Dehumidification Output

**TABLE 4  
HUMIDITY CONTROLS**

Part Number	Predominate Features
8403-038 (H600A1014)	SPDT switching, pilot duty 50VA @ 24V Humidity range 20-80% RH
8403-047 (H200-10-21-10)	Electronic dehumidistat SPST closes-on-rise Humidity range 10-90% with adjustable stops

**TABLE 5  
CO2 CONTROLLER**





Part Number	Predominate Features
8403-056 (C7232A1008)	Normally Open SPST relay closes-on-rise 24V with automatic background calibration Default setting is 800ppm, adjustable to 1000 or 1200, on-off differential is 100ppm 0-2000ppm range, with display

**TABLE 6  
THERMOSTAT WIRE SIZE**

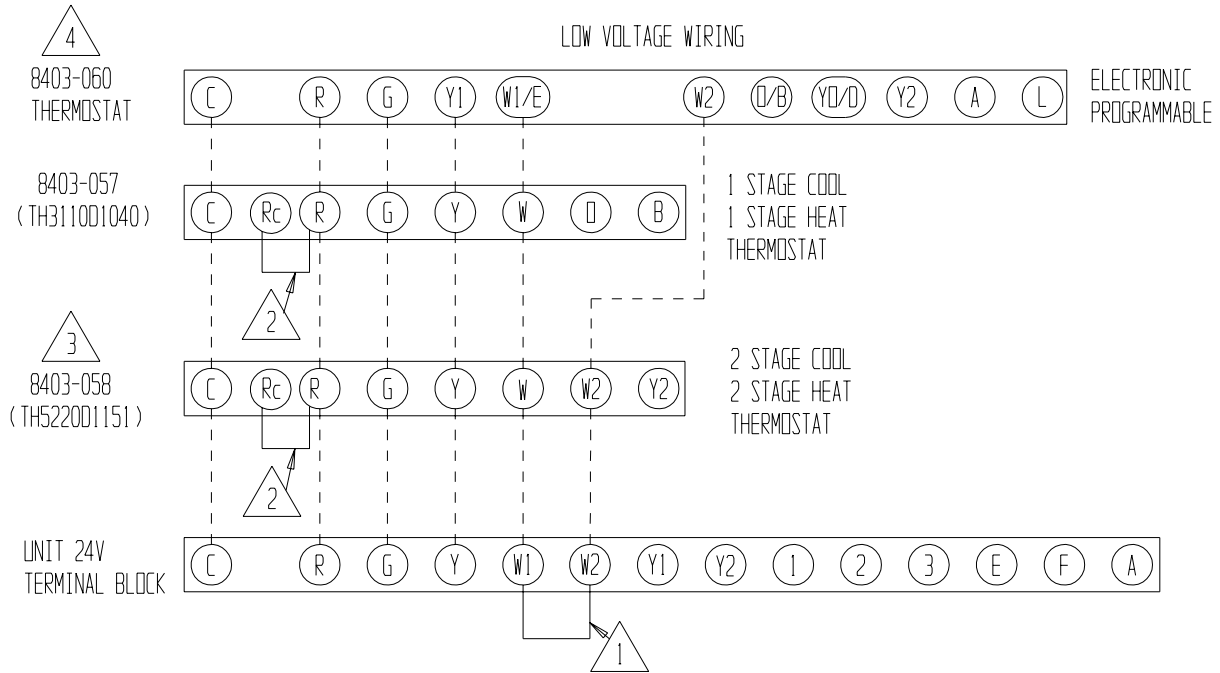
Transformer VA	FLA	Wire Gauge	Maximum Distance In Feet
55	2.3	20 gauge	45
		18 gauge	60
		16 gauge	100
		14 gauge	160
		12 gauge	250

**FIGURE 1**  
**BASIC A/C with OPTIONAL ELECTRIC HEAT**  
**NO ECONOMIZER or VENTILATION PACKAGES**



-  REMOVE JUMPER FOR 2 STAGE ELECTRIC HEAT ON UNITS WITH 15 OR MORE KW
-  FACTORY INSTALLED JUMPER
-  CHANGE "SYSTEM TYPE", SET UP FUNCTION 1, FROM 5 (2 HEAT/ 1 COOL HEAT PUMP) TO 6 (2 HEAT/ 2 COOL CONVENTIONAL).
-  CHANGE MODEL CONFIGURATION FROM HEAT PUMP TO HEAT/COOL.

MIS-2478 A

**FIGURE 2**  
**OPTIONAL MFAD, CRV or ERV VENTILATION PACKAGES**  
**with PROGRAMMABLE THERMOSTAT (RECOMMENDED)**

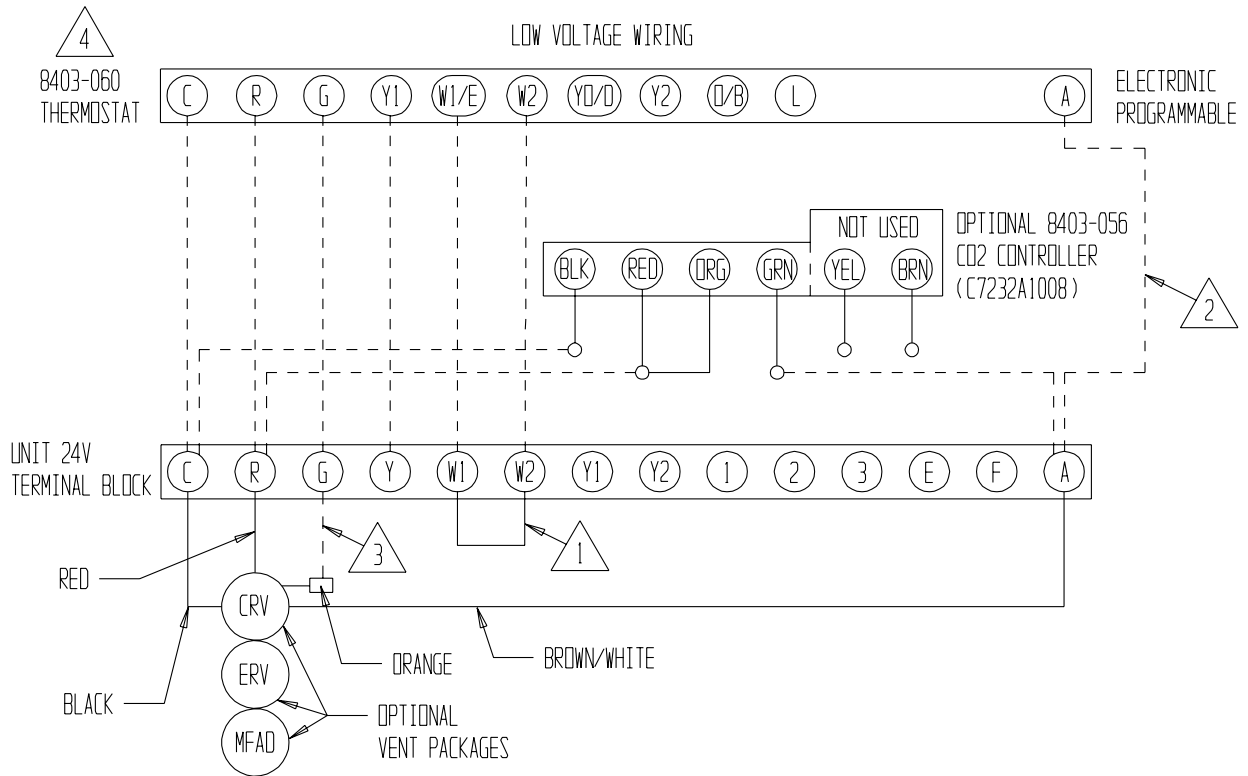

**1** REMOVE JUMPER FOR 2 STAGE ELECTRIC HEAT ON UNITS WITH 15 OR MORE KW

**2** DO NOT CONNECT "A" FROM 8403-060 IF OPTIONAL CO2 CONTROLLER IS USED

**3** CONNECT ORANGE WIRE TO "G" ONLY IF OPTIONAL CO<sub>2</sub> CONTROLLER IS USED





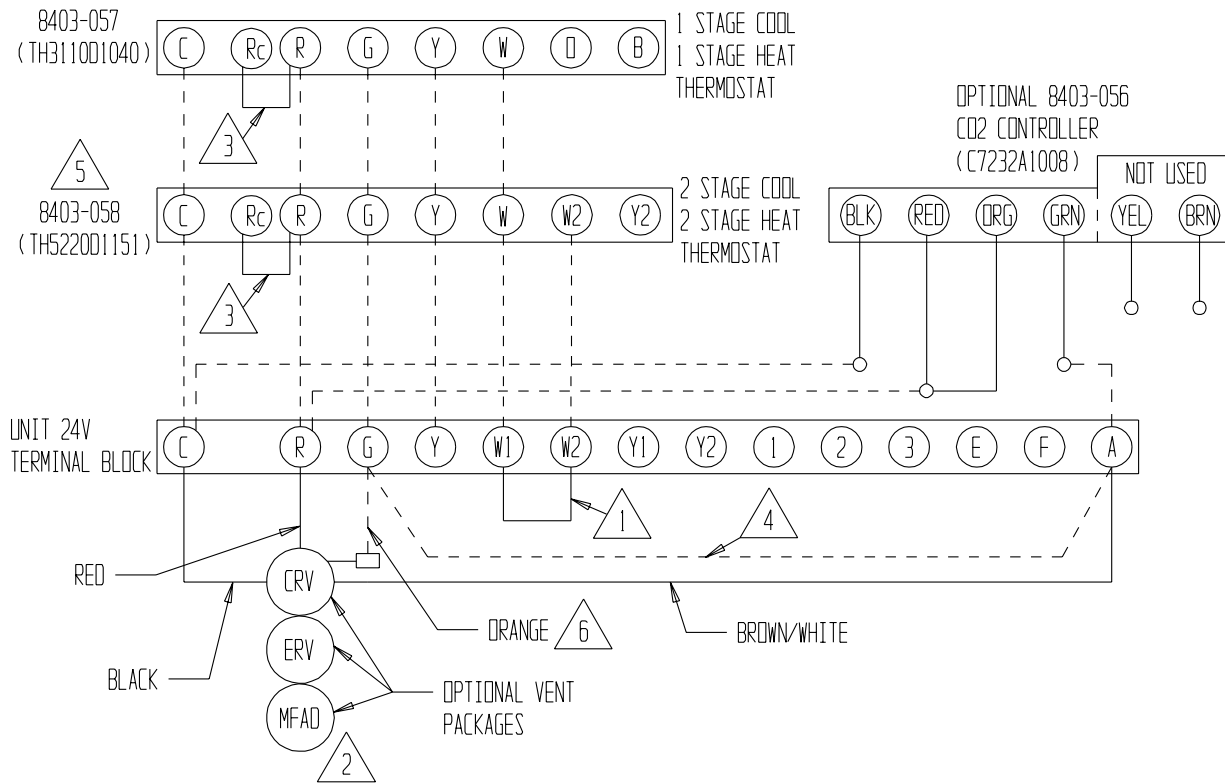

**4** CHANGE MODEL CONFIGURATION FROM HEAT PUMP TO HEAT/COOL

MIS-2479 A

**FIGURE 3**  
**OPTIONAL MFAD, CRV or ERV VENTILATION PACKAGES**  
**with NON-PROGRAMMABLE THERMOSTAT**

LOW VOLTAGE WIRING



-  REMOVE JUMPER FOR 2 STAGE ELECTRIC HEAT ON UNITS WITH 15 OR MORE KW
-  OPTIONAL VENT OPTION SUGGESTED HOOK UP
-  FACTORY INSTALLED JUMPER
-  ADD JUMPER IF OPTIONAL CO2 CONTROLLER IS NOT USED, VENT WILL RUN WHILE BLOWER IS ENERGIZED. DO NOT INSTALL JUMPER IF OPTIONAL CO2 CONTROLLER INSTALLED, AND SEE NOTE 6.
-  CHANGE "SYSTEM TYPE", SET UP FUNCTION 1, FROM 5 (2 HEAT/ 1 COOL HEAT PUMP) TO 6 (2 HEAT/ 2 COOL CONVENTIONAL).
-  CONNECT ORANGE WIRE TO "G" ONLY IF OPTIONAL CO2 CONTROLLER IS INSTALLED.

MIS-2480 A

**FIGURE 4**  
**A/C with ECONOMIZER**

OPTIONAL ECONOMIZER LOW VOLTAGE WIRING

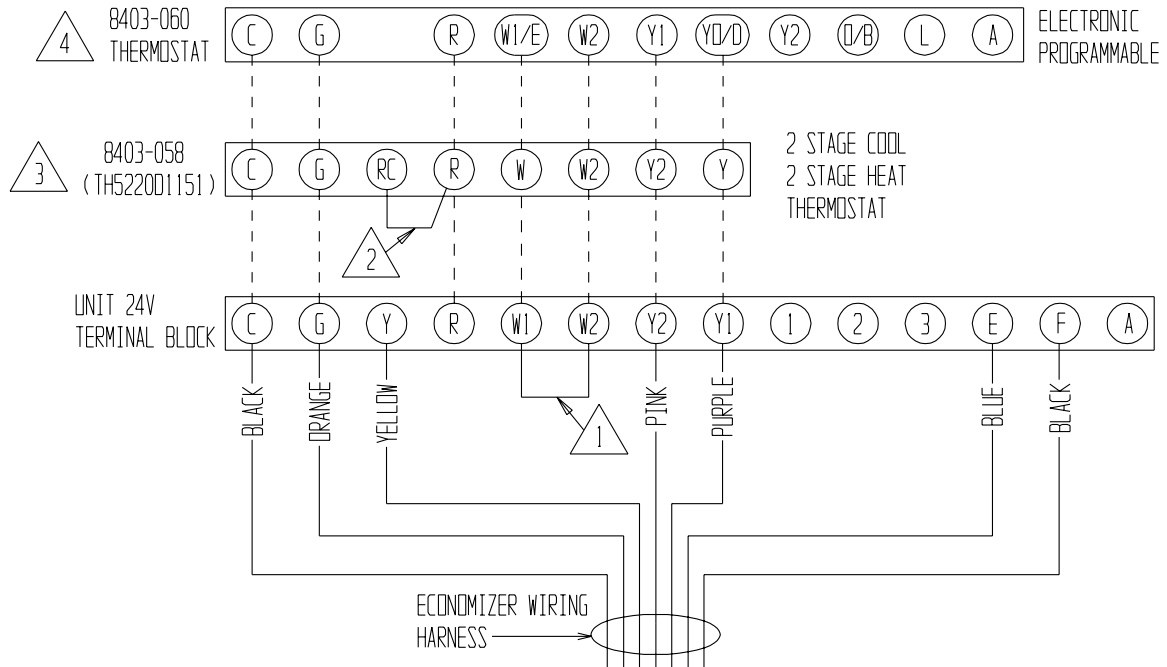

- 1** REMOVE JUMPER FOR 2 STAGE ELECTRIC HEAT ON UNITS WITH 15 OR MORE KW
- 2** FACTORY INSTALLED JUMPER
- 3** CHANGE "SYSTEM TYPE", SET UP FUNCTION 1, FROM 5 (2 HEAT/ 1 COOL HEAT PUMP) TO 6 (2 HEAT/ 2 COOL CONVENTIONAL).
- 4** CHANGE MODEL CONFIGURATION FROM HEAT PUMP TO HEAT/COOL, AND MUST BE CONFIGURED FOR ECONOMIZER FOR YD/D OUTPUT TO BE ACTIVE AS FIRST STAGE COOLING.

MIS-2481 A

**FIGURE 5**  
**A/C with DEHUMIDIFICATION SEQUENCE**  
**& NO VENTILATION PACKAGE USING**  
**8403-060 COMBINATION TEMPERATURE and HUMIDITY CONTROLLER**

LOW VOLTAGE WIRING

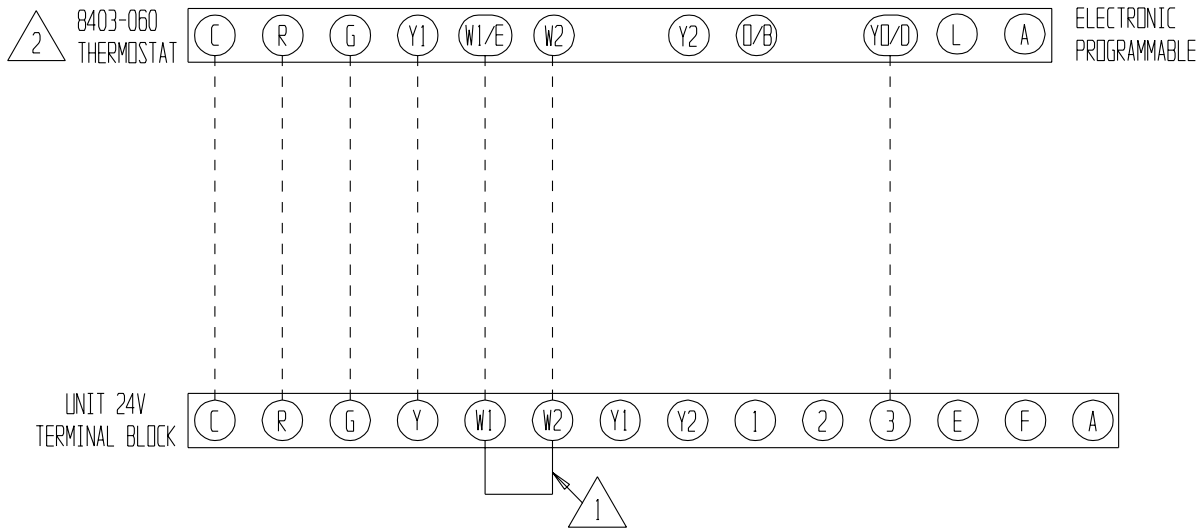

**1** REMOVE JUMPER FOR 2 STAGE ELECTRIC HEAT ON UNITS WITH 15 OR MORE KW

**2** CHANGE MODEL CONFIGURATION FROM HEAT PUMP TO HEAT/COOL, AND MUST BE CONFIGURED FOR "NO ECONOMIZER" TO MAKE YD/D OUTPUT ACTIVE FOR HUMIDITY CONTROL





MIS-2482 A

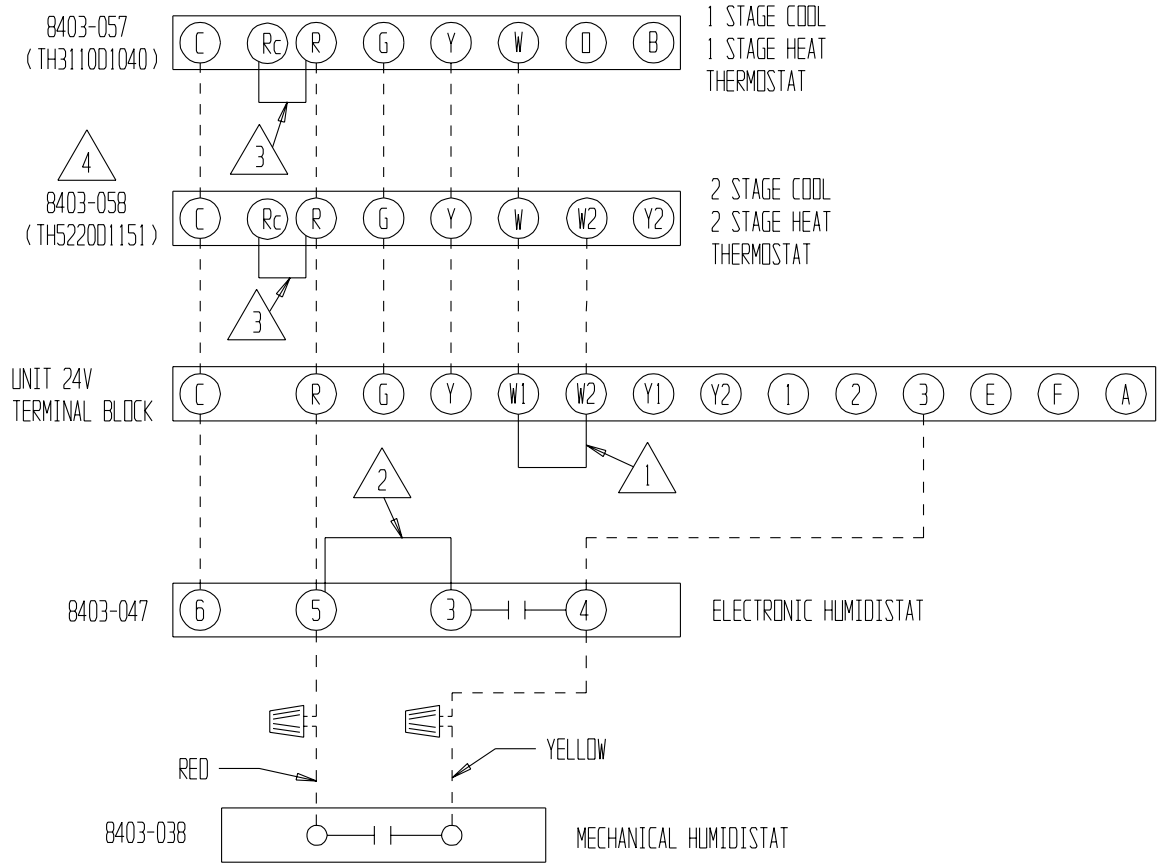

**FIGURE 6**  
**A/C with DEHUMIDIFICATION SEQUENCE**  
**& NO VENTILATION PACKAGE USING SEPARATE**  
**TEMPERATURE and HUMIDITY CONTROLS**

LOW VOLTAGE WIRING



-  REMOVE JUMPER FOR 2 STAGE ELECTRIC HEAT ON UNITS WITH 15 OR MORE KW
-  JUMPER NEEDS TO BE ADDED
-  FACTORY INSTALLED JUMPER
-  CHANGE "SYSTEM TYPE", SET UP FUNCTION 1, FROM 5 (2 HEAT/ 1 COOL HEAT PUMP) TO 6 (2 HEAT/ 2 COOL CONVENTIONAL).

MIS-2483 A

**FIGURE 7**  
**A/C with DEHUMIDIFICATION SEQUENCE**  
**with VENTILATION PACKAGE USING**  
**8403-060 COMBINATION TEMPERATURE and HUMIDITY CONTROLLER**

LOW VOLTAGE WIRING

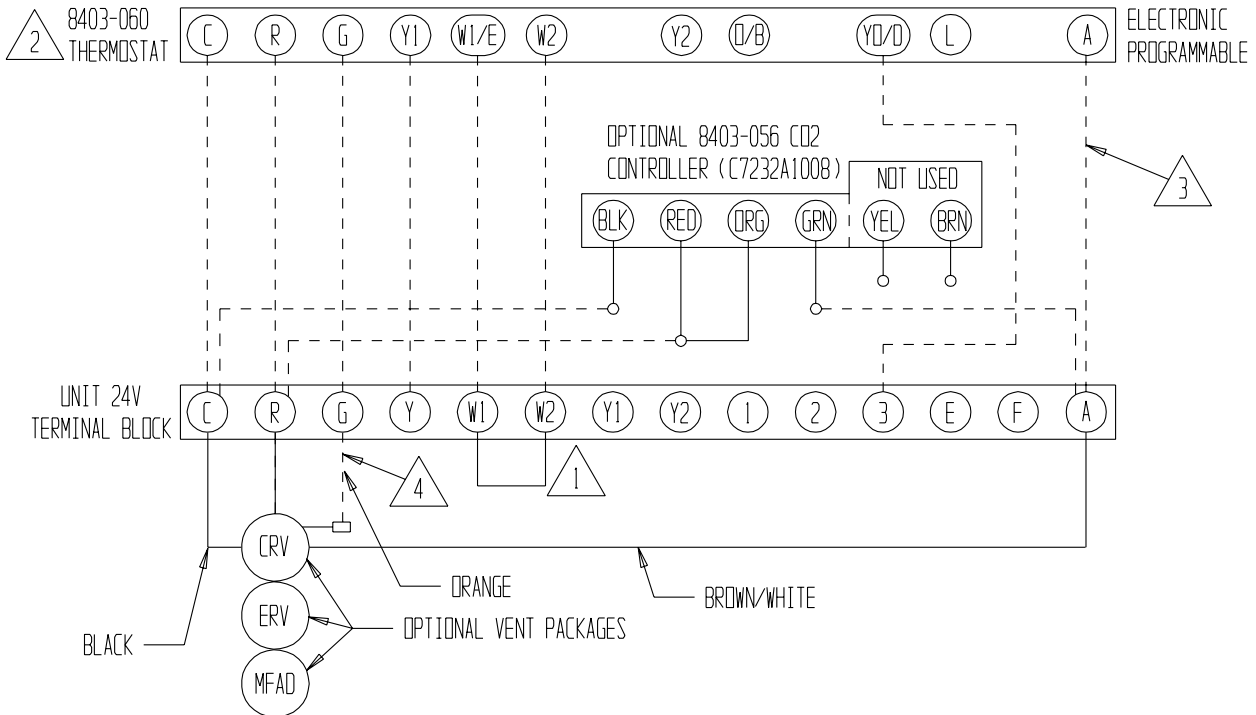





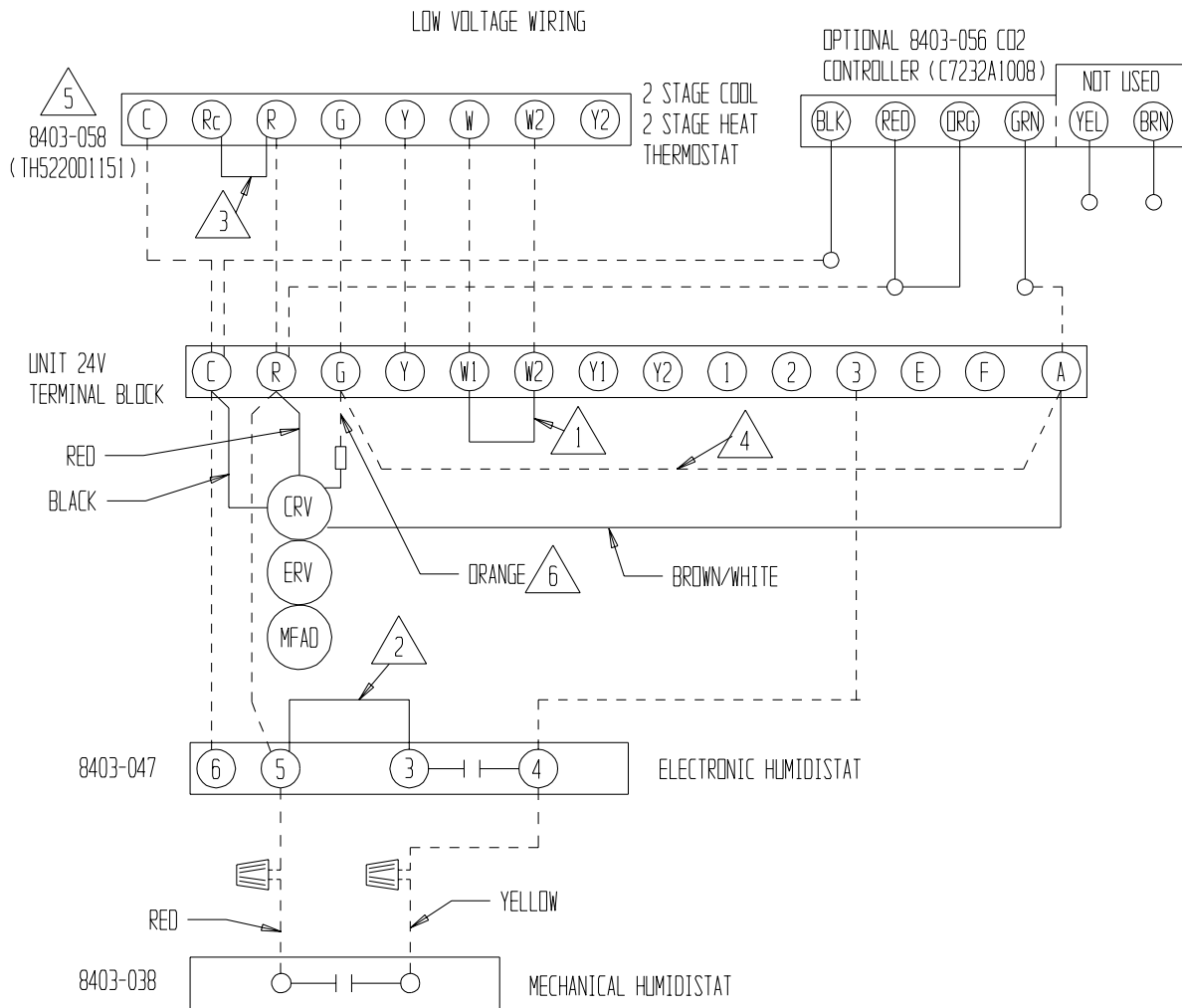

- 1** REMOVE JUMPER FOR 2 STAGE ELECTRIC HEAT ON UNITS WITH 15 OR MORE KW
- 2** CHANGE MODEL CONFIGURATION FROM HEAT PUMP TO HEAT/COOL, AND MUST BE CONFIGURED FOR "NO ECONOMIZER" TO MAKE YD/D OUTPUT ACTIVE FOR HUMIDITY CONTROL
- 3** DO NOT CONNECT "A" FROM 8403-060 IF OPTIONAL CO2 CONTROLLER IS USED
- 4** CONNECT ORANGE WIRE TO "G" ONLY IF OPTIONAL CO2 CONTROLLER IS USED.

MIS-2484 A

**FIGURE 8**  
**A/C with DEHUMIDIFICATION SEQUENCE**  
**with VENTILATION PACKAGE USING**  
**NON-PROGRAMMABLE THERMOSTAT**  
**and SEPARATE HUMIDITY CONTROLLER**





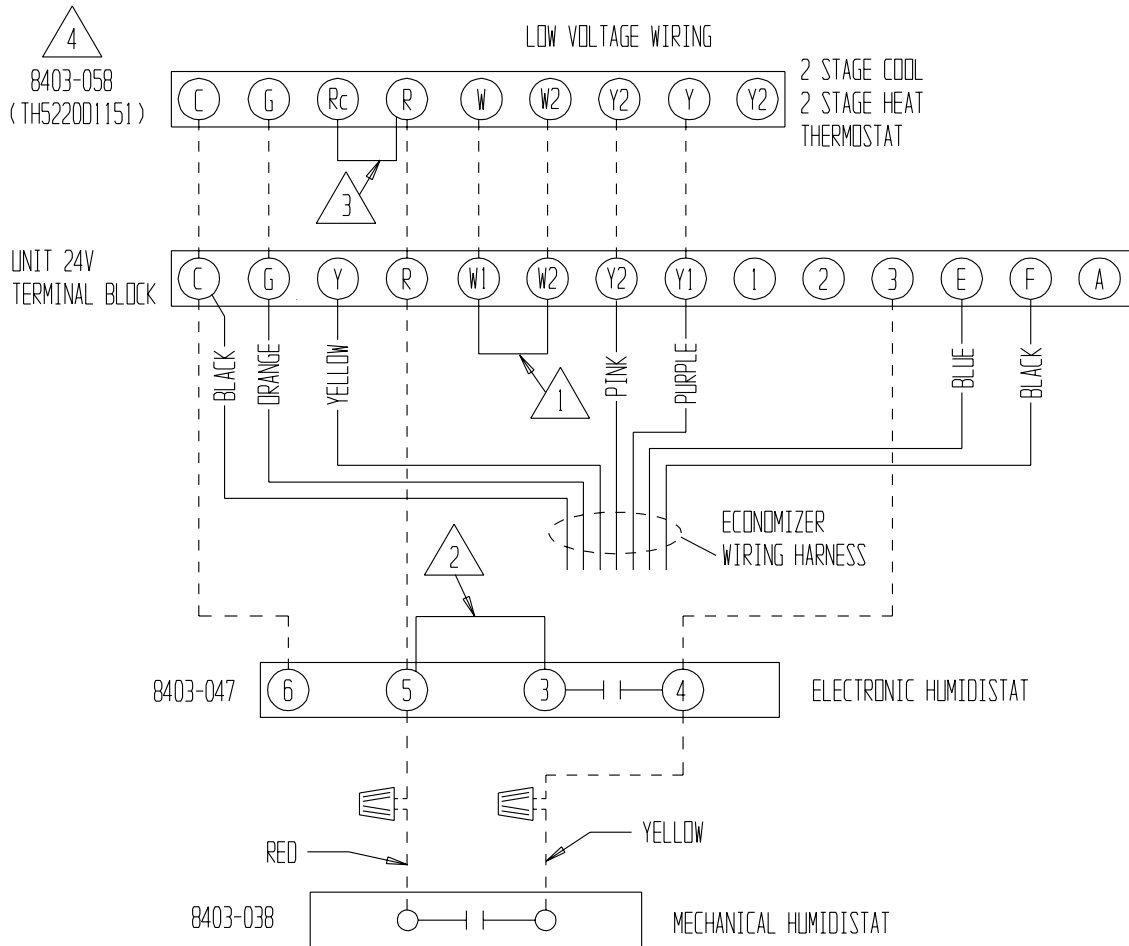

-  1 REMOVE JUMPER FOR 2 STAGE ELECTRIC HEAT ON UNITS WITH 15 OR MORE KW
-  2 JUMPER NEEDS TO BE ADDED
-  3 FACTORY INSTALLED JUMPER
-  4 ADD JUMPER IF OPTIONAL CO2 CONTROLLER IS NOT USED. VENT WILL RUN WHILE BLOWER IS ENERGIZED, IF CO2 CONTROLLER IS INSTALLED, DO NOT ADD JUMPER AND SEE NOTE 6.
-  5 CHANGE "SYSTEM TYPE", SET UP FUNCTION 1, FROM 5 (2 HEAT/ 1 COOL HEAT PUMP) TO 6 (2 HEAT/ 2 COOL CONVENTIONAL).
-  6 CONNECT ORANGE WIRE TO "G" ONLY IF OPTIONAL CO2 CONTROLLER IS INSTALLED.

MIS-2485 A

**FIGURE 9**  
**A/C with DEHUMIDIFICATION SEQUENCE**  
**& ECONOMIZER with 8403-058 THERMOSTAT**  
**and 8403-038 or 8403-047 HUMIDISTAT**



-  REMOVE JUMPER FOR 2 STAGE ELECTRIC HEAT ON UNITS WITH 15 OR MORE KW
-  JUMPER NEEDS TO BE ADDED
-  FACTORY INSTALLED JUMPER
-  CHANGE "SYSTEM TYPE", SET UP FUNCTION 1, FROM 5 (2 HEAT/ 1 COOL HEAT PUMP) TO 6 (2 HEAT/ 2 COOL CONVENTIONAL).

MIS-2497 A

**FIGURE 10**  
**A/C with DEHUMIDIFICATION SEQUENCE**  
**& ECONOMIZER with 8403-060**  
**COMBINATION TEMPERATURE and HUMIDITY CONTROL**

**LOW VOLTAGE WIRING**

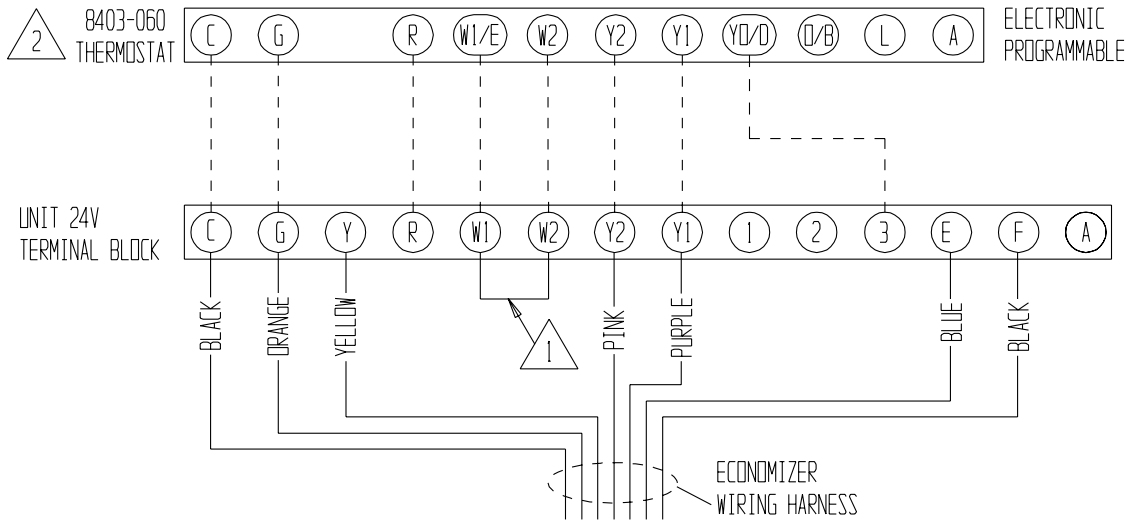

REMOVE JUMPER FOR 2 STAGE ELECTRIC HEAT ON UNITS WITH 15 OR MORE KW



CHANGE MODEL CONFIGURATION FROM HEAT PUMP TO HEAT/COOL, AND MUST BE CONFIGURED FOR NO ECONOMIZER AND MULTI-STAGE FOR Y1 OUTPUT TO BE ACTIVE AS FIRST STAGE COOLING AND YD/D TO BE ACTIVE FOR HUMIDITY CONTROL

MIS-2486 A

**FIGURE 11**

*AIR CONDITIONER WITH CS2000*

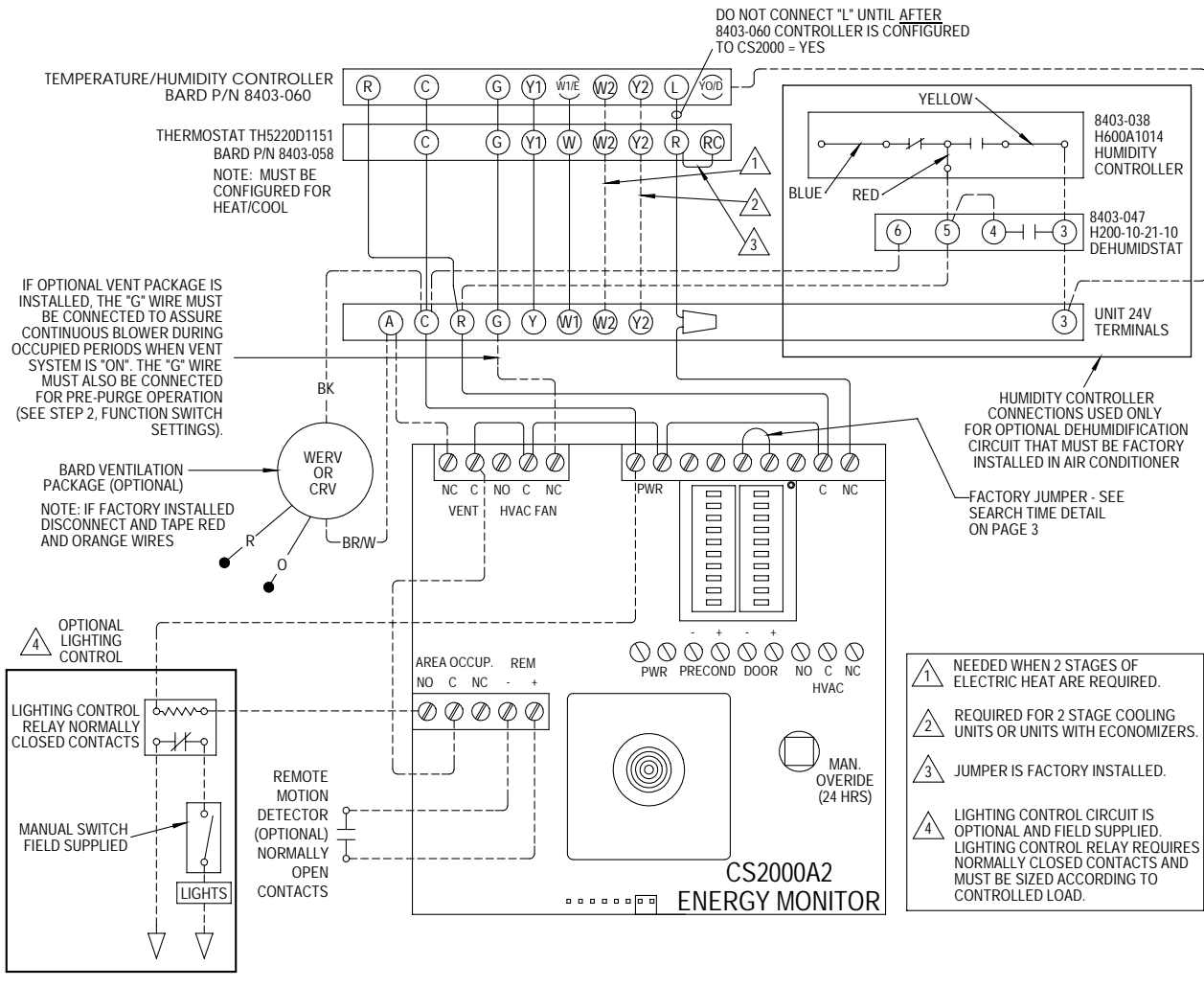

*RECOMMENDED SWITCH SETTINGS SHOWN BELOW*

FUNCTION SWITCHES		TEMPERATURE SWITCHES	
LEARN			90
PRE P			84
MODE			81
RATE			78
SEARCH-TIME			68
N/C			65
STAGE			62
AUX			58
DEMAND 2			54
DEMAND 1			48

4093-150 A