

INSTALLATION INSTRUCTIONS

WATER SOURCE HEAT PUMPS

Models: **GV27S1-A, GV38S1-A**
GV51S1-A, GV61S1-A
GV71S1-A

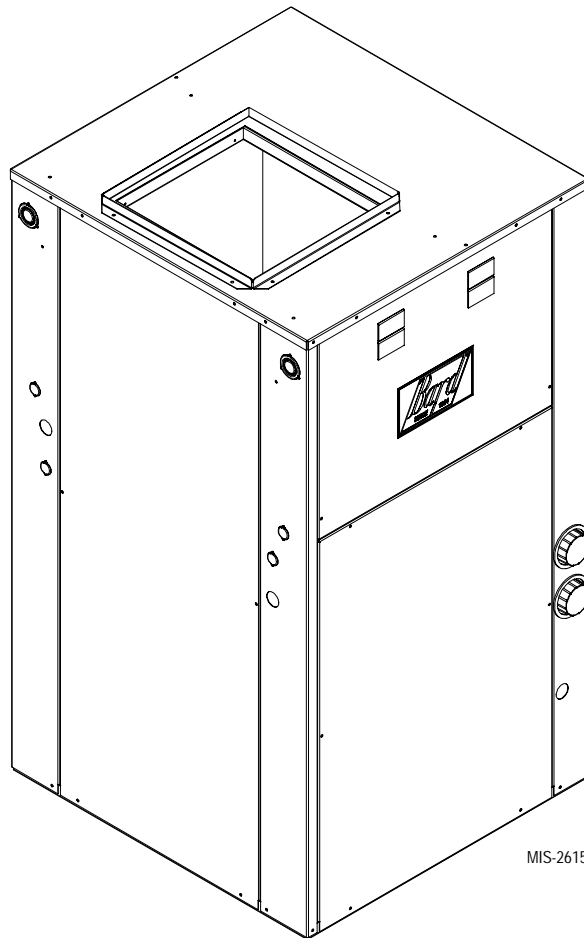

Earth Loop Fluid
Temperatures 25° - 110°
Ground Water Temperatures 45° - 75°



CLIMATE CONTROL SOLUTIONS

Bard Manufacturing Company, Inc.
Bryan, Ohio 43506
Since 1914...Moving ahead, just as planned.

Manual: 2100-510E
Supersedes: 2100-510D
File: Volume I, Tab 8
Date: 08-04-09

CONTENTS

Getting Other Informations and Publications 3

General Information

Water Source Nomenclature	4
Heater Package Nomenclature	8

Application and Location

General	9
Shipping Damage	9
Application	9
Location	9
Ductwork	9
Filters	11
Condensate Drain	11
Piping Access to Unit	11

Wiring Instructions

General	14
Control Circuit Wiring	14
Wall Thermostats	14
Thermostat Indicators	14
Emergency Heat Mode	14

Ground Loop (Earth Coupled Water Loop Applications)

Note	16
Circulation System Design	16
Start Up Procedure for Ground Loop System	17

Ground Water (Well System Applications)

Note	19
Water Connections	19
Well Pump Sizing	19 & 20
Start Up Procedure for Ground Water System	21

Water Corrosion	21 & 22
Remedies of Water Problems	22
Lake and/or Pond Installations	22 & 23

Sequence of Operation

Blower	24
Part Load Cooling	24
Full Load Cooling	24
Part Load Heating	24
Full Load Heating	24
Supplementary Electric Heat	24
Emergency Heat Mode	24
Compressor Control Module	25
Pressure Service Ports	25
System Start Up	25
Pressure Tables	28 & 29
Quick Reference Troubleshooting Chart	30

Service

Service Hints	31
Unbrazing System Components	31
Compressor Solenoid	31
Troubleshooting GE X13-Series Motors	32 & 33

Accessories

Add-On GVDM-26 Pump Module Kit	34
General	34
Installation	34

Ground Source Heat Pump

Performance Report 35-36

Wiring Diagrams 37-38

Figures

Figure 1 Unit Dimensions	7
Figure 2 Field-Conversion to Left Hand Return ..	10
Figure 3 Filter Rack Configuration	12
Figure 4 Piping Access	13
Figure 5 Thermostat Wiring	15
Figure 6 Circulation System Design	16
Figure 7 Temperature & Pressure Measurement ...	18
Figure 8 Model DORFC-1 Flow Center	18
Figure 9 Model DORFC-2 Flow Center	18
Figure 10 Water Connection Components	20
Figure 11 Cleaning Water Coil	22
Figure 12 Lake or Pond Installation	23
Figure 13 Component Location	26
Figure 14 Control Panel	26
Figure 15 Refrigerant Flow Diagrams	27
Figure 16A Pressure Tables	28
Figure 16B Pressure Tables	29
Figure 17 Motor Connections	32
Figure 18 Motor Connections	33
Figure 19 Typical Pump Kit Connection	34

Tables

Table 1 Indoor Blower Performance	4
Table 2 Flow Rates for Various Fluids	5
Table 3 Specifications	5
Table 4 Water Coil Pressure Drop	6
Table 5 Electrical Specifications Optional Field Installed Heater Package	8
Table Air Filter Table	11
Table 6 Control Circuit Wiring	14
Table 7 Wall Thermostat	14
Table 8 Constant Flow Valves	19

GETTING OTHER INFORMATION AND PUBLICATIONS

These publications can help you install the air conditioner or heat pump. You can usually find these at your local library or purchase them directly from the publisher. Be sure to consult current edition of each standard.

National Electrical Code ANSI/NFPA 70

Standard for the Installation ANSI/NFPA 90A
of Air Conditioning and Ventilating Systems

Standard for Warm Air ANSI/NFPA 90B
Heating and Air Conditioning Systems

Load Calculation for Residential ACCA Manual J
Winter and Summer Air Conditioning

Duct Design for Residential ACCA Manual D
Winter and Summer Air Conditioning and Equipment
Selection

Closed-Loop/Ground Source Heat Pump IGSHPA
Systems Installation Guide

Grouting Procedures for Ground-Source IGSHPA
Heat Pump Systems

Soil and Rock Classification for IGSHPA
the Design of Ground-Coupled Heat Pump Systems

Ground Source Installation Standards IGSHPA

Closed-Loop Geothermal Systems IGSHPA
– Slinky Installation Guide

FOR MORE INFORMATION, CONTACT THESE PUBLISHERS:

ACCA **Air Conditioning Contractors of America**
1712 New Hampshire Avenue
Washington, DC 20009
Telephone: (202) 483-9370
Fax: (202) 234-4721

ANSI **American National Standards Institute**
11 West Street, 13th Floor
New York, NY 10036
Telephone: (212) 642-4900
Fax: (212) 302-1286

ASHRAE **American Society of Heating Refrigerating,
and Air Conditioning Engineers, Inc.**
1791 Tullie Circle, N.E.
Atlanta, GA 30329-2305
Telephone: (404) 636-8400
Fax: (404) 321-5478

NFPA **National Fire Protection Association**
Batterymarch Park
P.O. Box 9101
Quincy, MA 02269-9901
Telephone: (800) 344-3555
Fax: (617) 984-7057

IGSHPA **International Ground Source
Heat Pump Association**
490 Cordell South
Stillwater, OK 74078-8018

WATER SOURCE PRODUCT LINE NOMENCLATURE

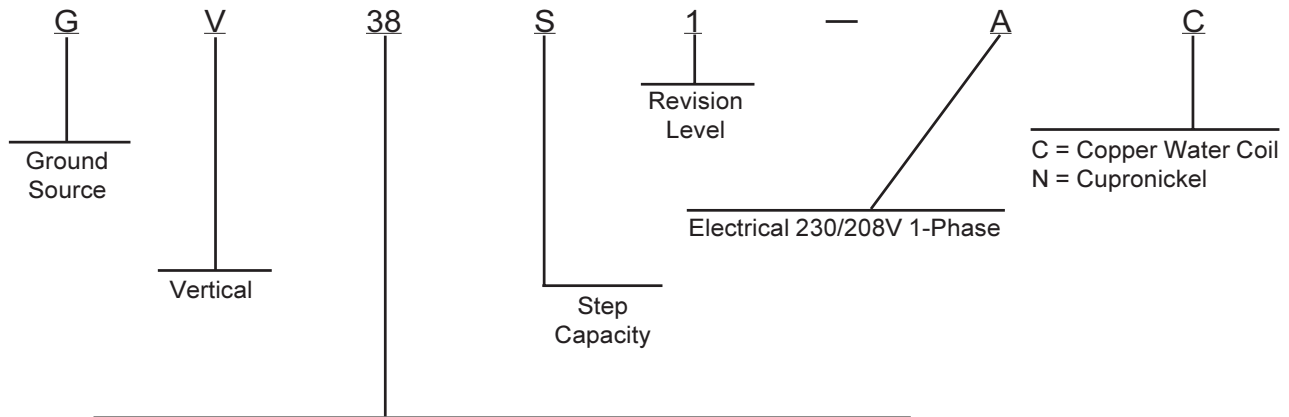

38 = Nominal heating capacity in thousands @ 50° water - Full Load
Nominal cooling capacity in thousands @ 77° brine - Full Load

TABLE 1
INDOOR BLOWER PERFORMANCE (RATED CFM) ①

MODEL	Motor HP	② Rated ESP	③ MAX ESP	Speed #1	Speed #2	Speed #3	Speed #4	Speed #5
				④ Continuous Airflow	⑤ Mild Weather Operation in 1 st Stage Cooling Mode (5-Min.)	⑥ Part Load Operation Airflow	⑦ -10% Full Load Airflow (Optional)	⑧ Full Load Airflow and Electric Heat Mode
GV27S1	1/3	0.15	0.50	500	650	800	900	1000
GV38S1	1/2	0.15	0.50	650	725	900	1175	1300
GV51S1	1/2	0.20	0.50	750	925	1150	1350	1500
GV61S1	3/4	0.20	0.50	800	1050	1300	1450	1600
GV71S1	3/4	0.25	0.50	875	1150	1450	1575	1750

- ① Motor will automatically step through the various airflows with thermostatic control
- ② ESP = External Static Pressure (inches of water)
- ③ Maximum allowable duct static
- ④ Continuous airflow is the CFM being circulated with manual fan operation without any additional function occurring.
- ⑤ Will occur automatically for first 5 minutes of Part Load Cooling Operation.
- ⑥ Will occur automatically after five minutes of Part Load Cooling Operation.
- ⑦ This is a field option for noisy installations to de-rate Full Load airflow (requires change in control panel).
- ⑧ Will occur automatically with control signal input (will not be defeated for electric heat operation).

**TABLE 2
FLOW RATES FOR VARIOUS FLUIDS**

VARIOUS FLUIDS	MODELS				
	GV27S	GV38S	GV51S	GV61S	GV71S
Flow rate required GPM fresh water ①	5	6	7	9	10
Flow rate required GPM 15% Sodium Chloride	7	9	12	15	16
Flow rate required GPM 25% GS4	7	9	12	15	16

① Rated Flow

**TABLE 3
SPECIFICATIONS**

MODEL	GV27S1-A*	GV38S1-A*	GV51S1-A*	GV61S1-A*	GV71S1-A*
Electrical Rating (60HZ/1PH)	230/208-1	230/208-1	230/208-1	230/208-1	230/208-1
Operating Voltage Range	253-197	253-197	253-197	253-197	253-197
Minimum Circuit Ampacity ①	17	26	32	38	41
+Field Wire Size ①	#12	#10	#8	#6	#6
++Delay Fuse Max. or Ckt. Bkr. ①	20	30	40	50	50
COMPRESSOR					
Volts	230/208	230/208	230/208	230/208	230/208
Rated Load Amps 230/208	8.4/10.1	12.4/14.5	17.4/20.6	22.4/27.4	24.7/28.5
Branch Ckt. Selection Current	10.2	16.7	21.2	27.4	28.5
Lock Rotor Amps 230/208	62/62	82/82	96/96	118/118	150/150
BLOWER MOTOR AND EVAPORATOR					
Blower Motor - HP/Speed/Type	1/3 / 5 / ECM	1/2 / 5 / ECM	1/2 / 5 / ECM	3/4 / 5 / ECM	3/4 / 5 / ECM
Blower Motor - Amps	1.5 / 1.6	2.5 / 2.95	2.8 / 3.0	3.8 / 4.1	4.1 / 4.2
Face Area Sq. Ft./Row/Fins Per Inch	3.16 / 4 / 11	3.16 / 4 / 11	5.33 / 3 / 11	5.33 / 4 / 11	5.33 / 5 / 10

+75°C copper wire ++ HACR type circuit breaker

* C - for copper / N for Cupro-Nickel water coil

① Heat pump only. Optional field-installed heaters are separate circuit.

**TABLE 4
WATER COIL PRESSURE DROP**

Model GPM	GV27S1		GV38S1 / GV51S1		GV61S1		GV71S1	
	PSID	Ft. Hd.	PSID	Ft. Hd.	PSID	Ft. Hd.	PSID	Ft. Hd.
3	0.1	0.23						
4	0.5	1.15	0.9	2.08				
5	1.2	2.77	1.4	3.23				
6	1.7	3.92	2.3	5.31				
7	2.3	5.31	3.2	7.38	2	4.61		
8	3.1	7.15	4.1	9.46	2.5	5.77	2	4.61
9	4.1	9.46	5.1	11.77	3.2	7.38	2.4	5.54
10			6.1	14.07	3.9	9.00	2.8	6.46
11			7.1	16.38	4.7	10.84	3.4	7.84
12			8.2	18.92	5.5	12.69	3.9	9.00
13			9.4	21.69	6.4	14.76	4.5	10.38
14			10.6	24.45	7.3	16.84	5.2	12.00
15					8.1	18.69	5.9	13.61
16					9	20.76	6.7	15.46
17					9.9	22.84	7.4	17.07
18							8.4	19.38

FIGURE 1 – UNIT DIMENSIONS

Units	Width		Depth		Supply		Return		A	B	C	D	E	F	G	H	I	J	K	L	M	N	O	P	Q	R	S	T	U	V	W	X	Y
	A	B	C	D	Duct	Flange	Width	Height																									
GV27 - 38S1	27-5/8	26	48	13-7/8	13-7/8	18	22-3/4	6-7/8	2-7/16	1-1/2	45-1/4	31-5/8	1-5/8	2-1/4	3-1/4	29-1/16	25-13/16	8-3/16	19-1/2	15-1/2	2-1/16	7-3/8	23-1/8	25-7/16	1-1/4								
GV51 - 71S1	32-5/8	27	55-5/8	17-7/8	17-7/8	23-1/2	29-7/8	7	2-7/16	1-1/2	52-7/8	32-1/4	1-5/8	2-1/2	3-1/2	29-3/4	26-13/16	8-1/16	19-5/16	15-5/16	2-1/16	9-7/8	25-5/8	30-7/16	1-5/16								

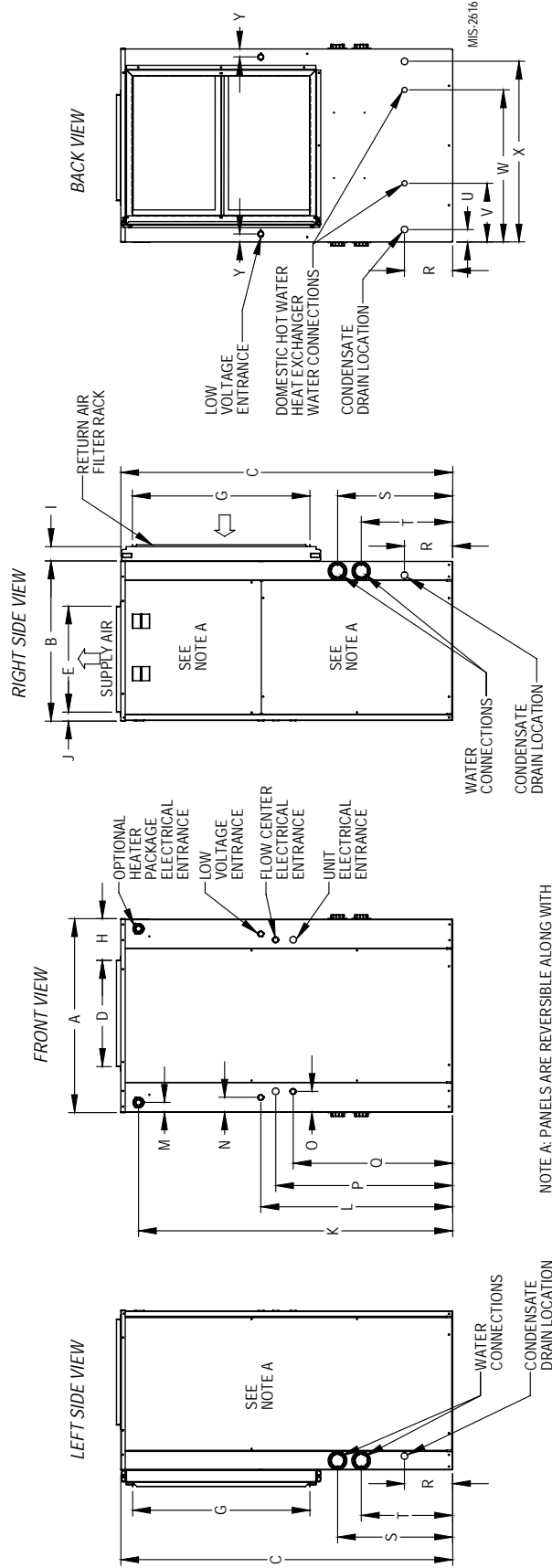
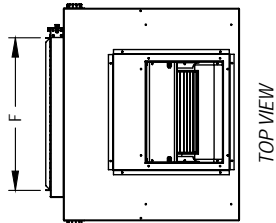

NOTE A: PANELS ARE REVERSIBLE ALONG WITH CONTROL PANELS FOR HEAT PUMP AND ELECTRIC HEATER PACKAGE FOR BEST INSTALLATION POSITION.

HEATER PACKAGE NOMENCLATURE

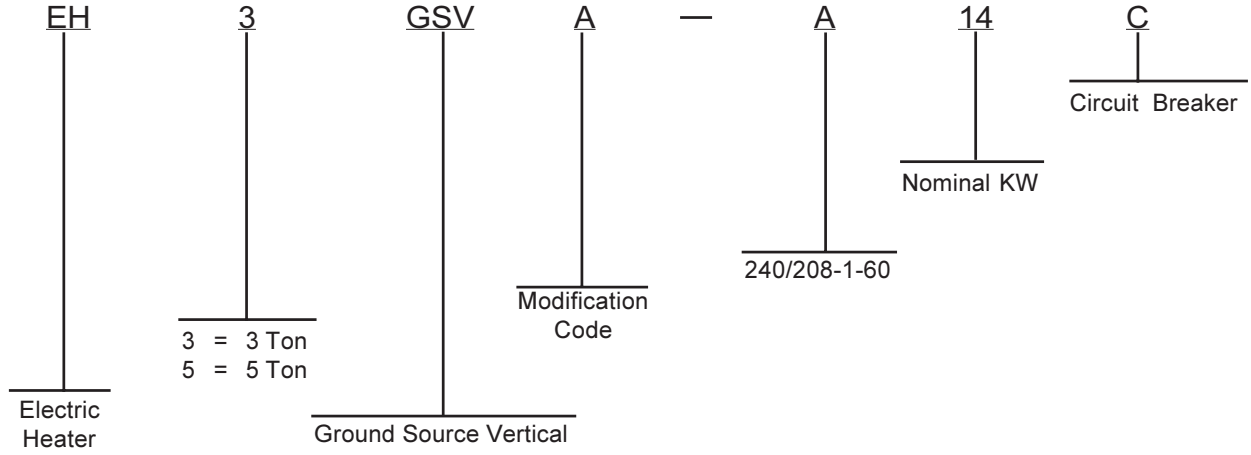

**TABLE 5
ELECTRICAL SPECIFICATIONS**

Electrical Specifications - Optional Field-Installed Heater Packages											
For Use with Models	Heater Package Model No.	Heater Package Volts/Phase 60 HZ	Heater Amps, KW and Capacity @ 240 Volts			Heater Amps, KW and Capacity @ 208 Volts			Minimum Circuit Ampacity	Maximum HACR Circuit Breaker	Field Wire Size+
			AMPS	KW	BTU	AMPS	KW	BTU			
GV27S1-A & GV38S1-A	EH3GSVA-A05C	240/208-1	18.8	4.5	15,345	16.3	3.38	11,525	23.5	25	10
	EH3GSVA-A09C	240/208-1	37.5	9.0	30,690	32.5	6.75	23,018	46.9	50	8
	EH3GSVA-A14C	240/208-1	56.3	13.5	46,035	48.7	10.13	34,543	70.4	80	4

Electrical Specifications - Optional Field-Installed Heater Packages											
For Use with Models	Heater Package Model No.	Heater Package Volts/Phase 60 HZ	Heater Amps, KW and Capacity @ 240 Volts			Heater Amps, KW and Capacity @ 208 Volts			Minimum Circuit Ampacity	Maximum HACR Circuit Breaker	Field Wire Size+
			AMPS	KW	BTU	AMPS	KW	BTU			
GV51S1-A GV61S1-A & GV71S1-A	EH5GSVA-A09C	240/208-1	37.5	9.0	30,690	32.5	6.75	23,018	46.9	50	8
	EH5GSVA-A14C	240/208-1	56.3	13.5	46,035	48.7	10.13	34,543	70.4	80	4
	EH5GSVA-A18C	240/208-1	75.0	18.0	61,380	64.9	13.5	46,035	98.3	100	3

+ Based on 75F copper wire. All wiring must conform to National Electrical Code (latest edition) and all local codes.

APPLICATION AND LOCATION

GENERAL

Units are shipped completely assembled and internally wired, requiring only duct connections, thermostat wiring, 230/208 volt AC power wiring, and water piping. The equipment covered in this manual is to be installed by trained, experienced service and installation technicians.

These instructions and any instructions packaged with any separate equipment required to make up the entire heat pump system should be carefully read before beginning the installation. Note particularly any tags and/or labels attached to the equipment.

While these instructions are intended as a general recommended guide, they do not in any way supersede any national and/or local codes. Authorities having jurisdiction should be consulted before the installation is made.

SHIPPING DAMAGE

Upon receipt of the equipment, the carton should be checked for external signs of shipping damage. If damage is found, the receiving party must contact the last carrier immediately, preferably in writing, requesting inspection by the carrier's agent.

APPLICATION

Capacity of the unit for a proposed installation should be based on heat loss calculations made in accordance with methods of the Air Conditioning Contractors of America. The air duct system should be sized and installed in accordance with Standards of the National Fire Protection Association for the Installation of Air Conditioning and Venting systems of Other than Residence Type NFPA No. 90A, and residence Type Warm Air Heating and Air Conditioning Systems, NFPA No. 90B.

LOCATION

The unit may be installed in a basement, closet, or utility room provided adequate service access is insured. The unit is shipped from the factory as a right hand return and requires **access clearance of two feet minimum to the access panels on this side of the unit.** If unit is to be field converted to left hand return the opposite side will require access clearance of two feet minimum.

Unit may be field converted to left hand return by removing two (2) screws that secure the control panel cover, removing four (4) screws that hold the control panel in place, laying the control panel down, sliding it under the blower and re-securing the control panel on the opposite side of the unit. (See Figure 2.) The two (2) access doors from the right hand return can be transferred to the left-hand return side and the one (1) left-hand panel can be transferred to the right hand side.

Unit casing suitable for 0 inch clearance with 1-inch duct clearance for at least the first 3 feet of duct. These units are not approved for outdoor installation and therefore must be installed inside the structure being conditioned.

Do not locate in areas subject to freezing in the winter or subject to sweating in the summer.

Before setting the unit, consider ease of piping, drain and electrical connections for the unit. Also, for units which will be used with a field installed heat recovery unit, consider the proximity of the unit to the water heater or storage tank. Place the unit on a solid base, preferably concrete, to minimize undesirable noise and vibration. ***DO NOT*** elevate the base pan on rubber or cork vibration eliminator pads as this will permit the unit base to act like a drum, transmitting objectionable noise.

DUCTWORK

If the unit is to be installed in a closet or utility room which does not have a floor drain, a secondary drain pan under the entire unit is highly recommended.

DO NOT install the unit in such a way that a direct path exists between any return grille and the unit. Rather, insure that the air entering the return grille will make at least one turn before entering the unit or coil. This will reduce possible objectionable compressor and air noise from entering the occupied space.

Design the ductwork according to methods given by the Air Conditioning Contractors of America. When duct runs through unconditioned spaces, it should be insulated with vapor barrier. It is recommended that flexible connections be used to connect the ductwork to the unit in order to keep the noise transmission to a minimum.

WARNING

Failure to provide the 1-inch clearance between the supply duct and a combustible surface for the first 3 feet of duct can result in a fire.

FIGURE 2
FIELD-CONVERSION TO LEFT HAND RETURN

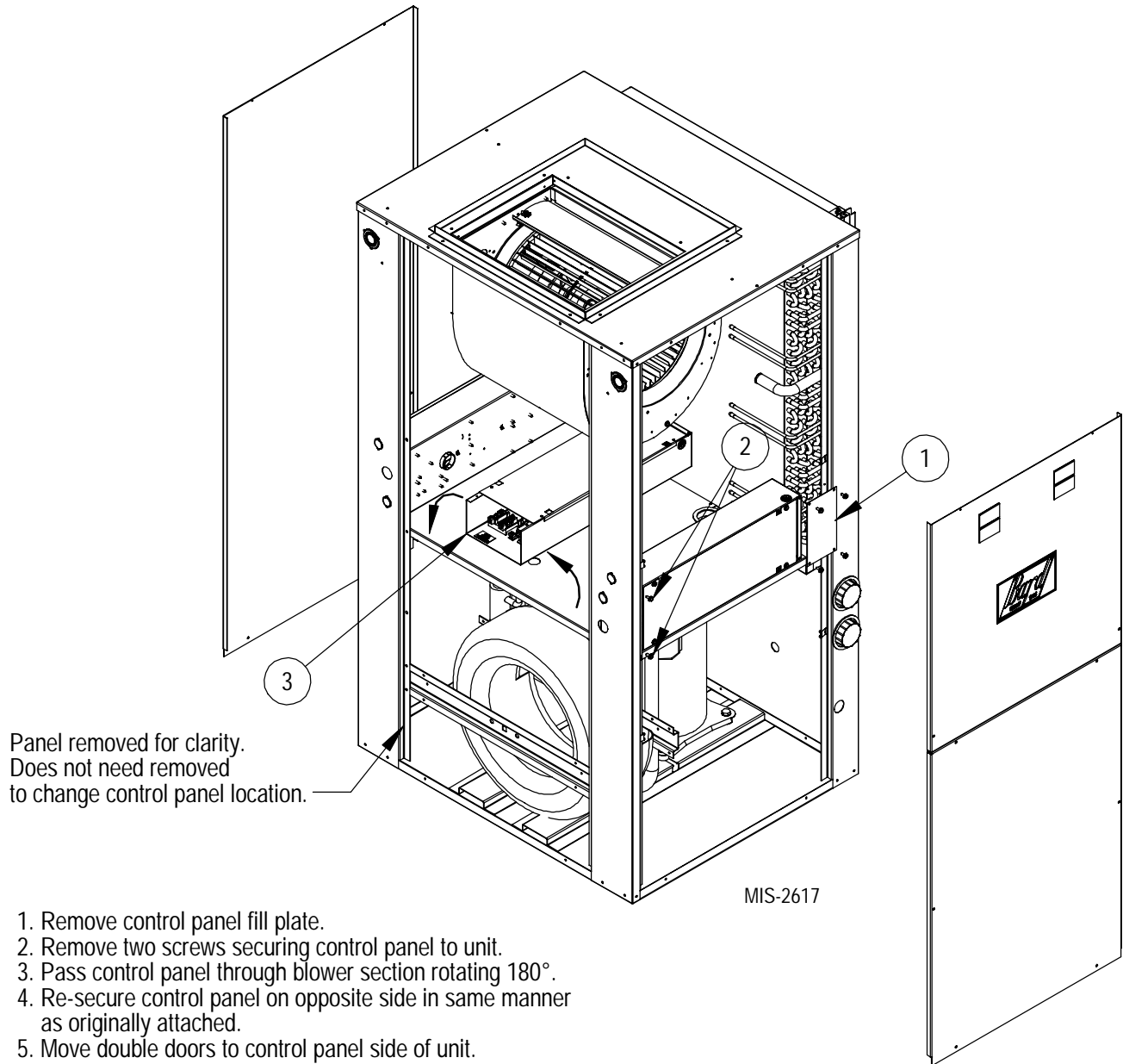

FILTER

This unit must not be operated without a filter. It comes equipped with 2" disposable filters, which should be checked often and replaced if dirty. Insufficient airflow due to undersized duct systems or dirty filters can result in nuisance tripping of the high or low pressure controls. Refer to Table 2 for correct airflow and static pressure requirements.

NOTE: The filter rack is installed on the unit as shipped for right-hand return. If you require left-hand return, you will need to remove the filter access door and remove the screws holding the filter rack to the unit (slide downward from underneath unit top). Invert the filter rack 180° to move filter access door to the other side of the unit, and reverse the previous steps (see Figure 3).

NOTE: You will need to bend the duct attachment flanges up using duct bills or similar device, as the unit is shipped with them collapsed.

AIR FILTERS

Model	Filter Size	Quantity
GV27S GV38S	20" x 25" x 2"	1
GV51S GV61S GV71S	16" x 25" x 2"	2

CONDENSATE DRAIN

Drain lines must be installed according to local plumbing codes. It is not recommended that any condensate drain line be connected to a sewer main.

Determine where the drain line will run and then select one of four (4) locations for the condensate to exit the unit casing (see Figure 4). There are knockouts in the unit casing that can be selected for the condensate exit. Internal of the unit, there is a clear flexible hose with a termination fitting installed. When installed properly, this hose will create a trap internal of the unit and will remain serviceable if the drain system requires cleaning or service. Supplied in the parts bag of the unit is a 3/4" PVC male adaptor that will secure the internal drain components to the sheet metal casing at the location you selected.

NOTE: This drain line will contain cold water and must be insulated to avoid droplets of water from condensing on the pipe and dripping on finished floors or the ceiling below the unit.

PIPING ACCESS TO UNIT

Water piping to and from the unit enters the unit cabinet on either side of the unit. The connection directly at the unit is a special double o-ring fitting with a retainer nut that secures it in place. (It is the same style fitting used for the flow center connection on ground loop applications.) You may come in and out either side of the unit in any combination as the installation dictates. One side has both connections closed off with a double o-ring plug seal with retaining caps. One or both of these are transferred to opposite side - depending upon installation requirements.

Note: All double o-ring fittings require "hand tightening only". Do not use wrench or pliers as retainer nut can be damaged with excessive force.

Various fittings are available so you may then connect to the unit with various materials and methods. These methods include 1" barbed fittings (straight and 90°), 1" MPT (straight and 90°), and 1-1/4" hot fusion fitting (straight only) (see Figures 3 & 4).

**FIGURE 3
FILTER RACK – GV MODELS**

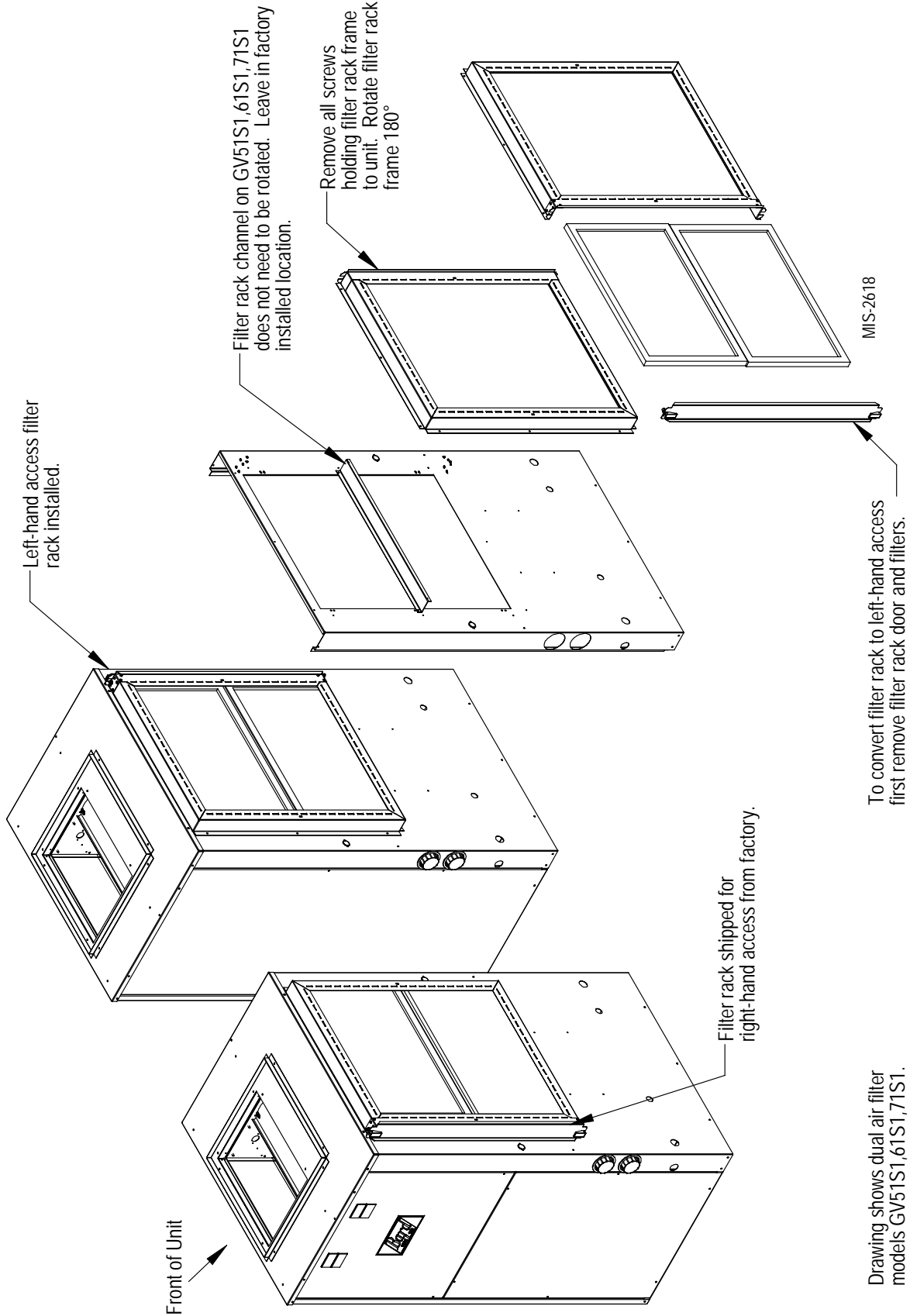

Drawing shows dual air filter models GV51S1,61S1,71S1. GV27S1,38S1 have only one air filter.

FIGURE 4
CONDENSATE DRAIN & PIPING ACCESS TO UNIT

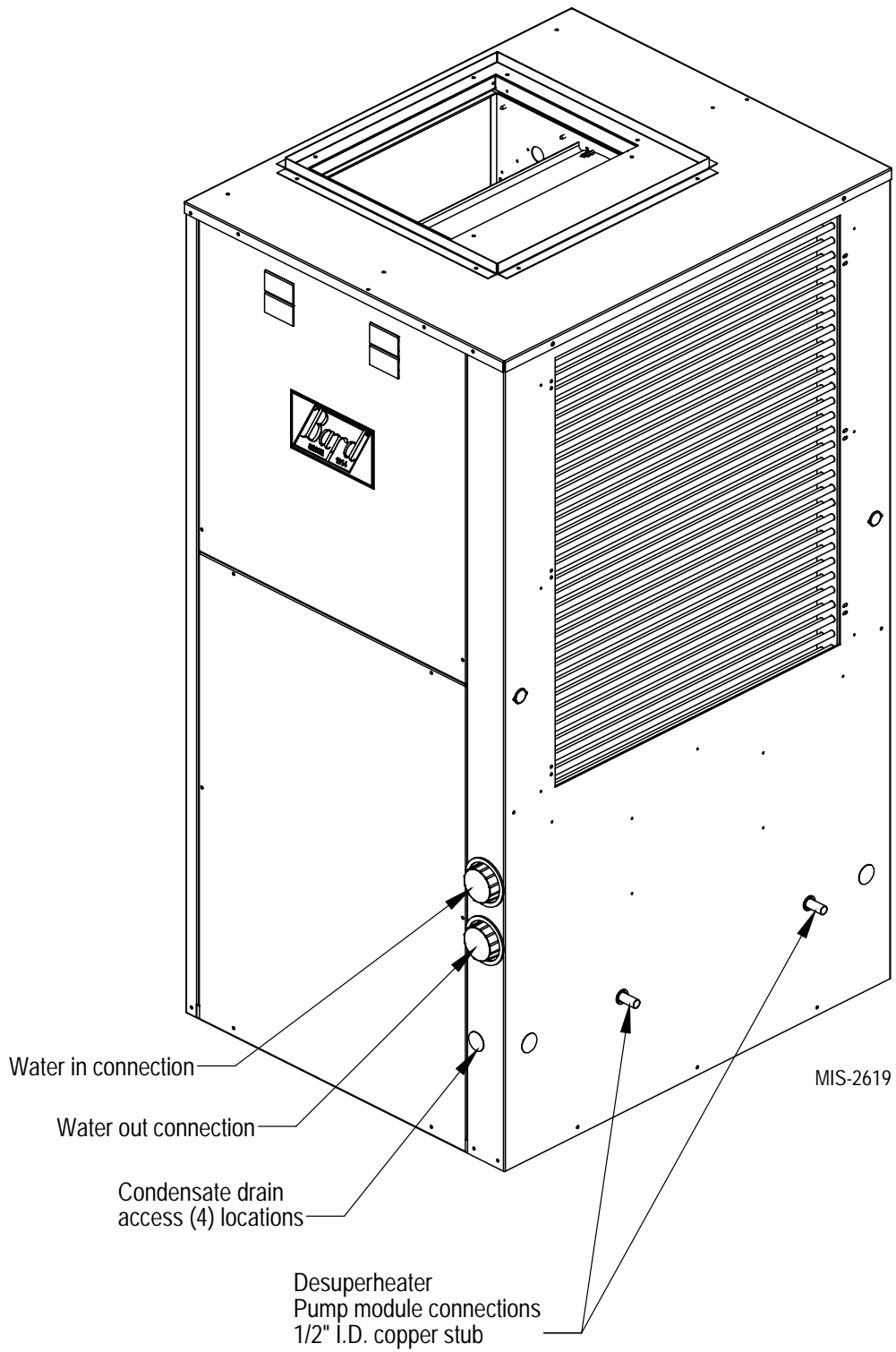

WIRING INSTRUCTIONS

GENERAL

All wiring must be installed in accordance with the National Electrical Code and local codes. In Canada, all wiring must be installed in accordance with the Canadian Electrical Code and in accordance with the regulations of the authorities having jurisdiction. Power supply voltage must conform to the voltage shown on the unit serial plate. A wiring diagram of the unit is attached to the inside of the electrical cover. The power supply shall be sized and fused according to the specifications supplied. A ground lug is supplied in the control compartment for equipment ground.

The unit rating plate lists a “Maximum Time Delay Fuse” or “HACR” type circuit breaker that is to be used with the equipment. The correct size must be used for proper circuit protection and also to assure that there will be no nuisance tripping due to the momentary high starting current of the compressor motor.

CONTROL CIRCUIT WIRING

The minimum control circuit wiring gauge needed to insure proper operation of all controls in the unit will depend on two factors.

1. The rated VA of the control circuit transformer.
2. The maximum total distance of the control circuit wiring.

Table 6 should be used to determine proper gauge of control circuit wiring required.

**TABLE 6
CONTROL CIRCUIT WIRING**

Rated VA of Control Circuit Transformer	Transformer Secondary FLA @ 24V	Maximum Total Distance of Control Circuit Wiring in Feet
50	2.1	20 gauge - 45 18 gauge - 60 16 gauge - 100 14 gauge - 160 12 gauge - 250

Example: 1. Control Circuit transformer rated at 50 VA
2. Maximum total distance of control circuit wiring 85 feet.

From Table 6 minimum of 16 gauge wire should be used in the control circuit wiring.

WALL THERMOSTAT

The following thermostat should be used as indicated, depending on the application.

**TABLE 7
WALL THERMOSTAT**

Thermostat	Predominant Features
8403-060 (1120-445)	3 stage Cool; 3 stage Heat Programmable/Non-Programmable Electronic HP or Conventional Auto or Manual changeover

THERMOSTAT INDICATORS

8403-060 (1120-445) Temperature/Humidity Control:

In heating or cooling, the display may be black and light gray, or backlit in blue depending on configuration. In the event of a system malfunction such as a loss of charge or high head pressure, the heat pump control board will issue a signal to the thermostat causing the screen to be backlit in RED and the display to read “Service Needed”. If this occurs, the control will continue to function, but you will not be able to make any adjustments until the problem is corrected and the fault device is reset.

EMERGENCY HEAT MODE

The operator of the equipment must manually place the system switch in this mode. This is done when there is a known problem with the unit.

When the 8403-060 (1120-445) Temperature/Humidity Control is placed in the Emergency Heat mode, the display will be backlit in RED to indicate that service is needed. The display will remain backlit in red until the mode is switched out of Emergency Heat.

FIGURE 5 THERMOSTAT WIRING

GROUND LOOP APPLICATIONS (when utilized with a flow center)

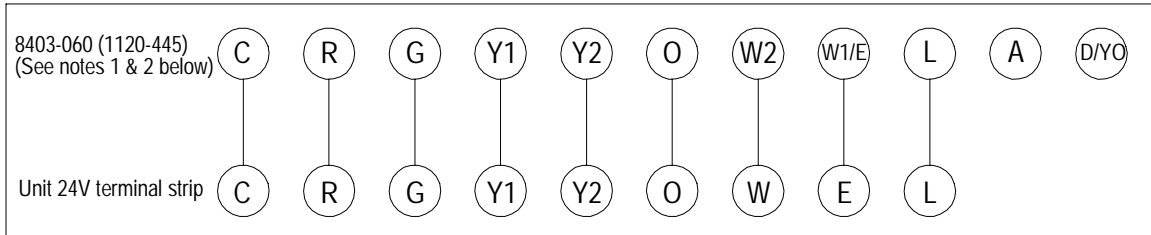

GROUND WATER APPLICATIONS (when installed with recommended motorized valve with end switch)

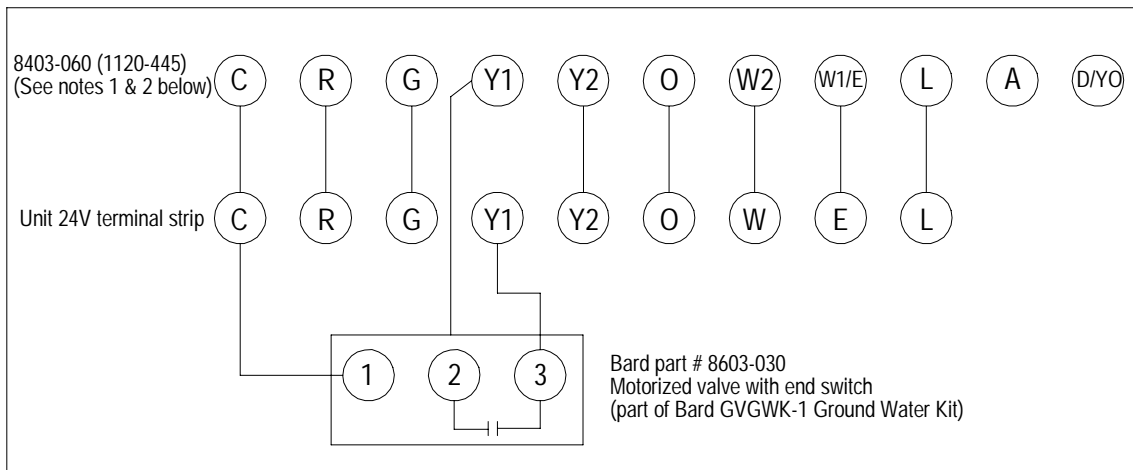

GROUND WATER APPLICATIONS (when installed with Standard two-wire solenoid valve)

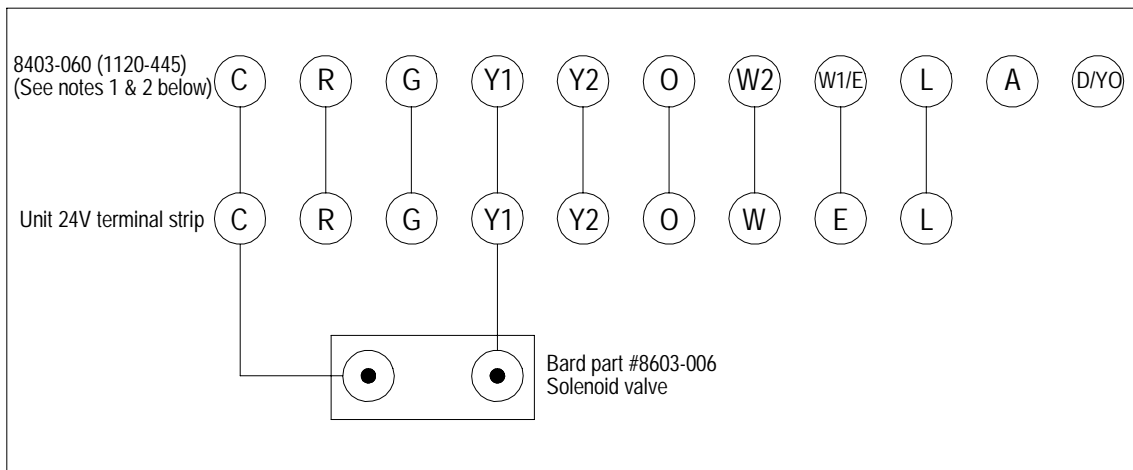

1. Will need to be programmed for multi-stage heat pump
2. Will need to be configured to energize reversing valve for cooling mode
3. All wiring field supplied low voltage

MIS-2620 B

GROUND LOOP (EARTH COUPLED WATER LOOP APPLICATIONS)

NOTE:

Unit shipped from factory with 60 PSIG low pressure switch wired into control circuit and must be rewired to 45 PSIG low pressure switch for ground loop applications. This unit is designed to work on earth coupled water loop systems, however, these systems operate at entering water (without antifreeze) temperature with pressures well below the pressures normally experienced in water well systems.

THE CIRCULATION SYSTEM DESIGN

Equipment room piping design is based on years of experience with earth coupled heat pump systems. The design eliminates most causes of system failure.

The heat pump itself is rarely the cause. Most problems occur because designers and installers forget that a ground loop “earth coupled” heat pump system is NOT like a household plumbing system.

Most household water systems have more than enough water pressure either from the well pump of the municipal water system to overcome the pressure of

head loss in 1/2 inch or 3/4 inch household plumbing. A closed loop earth coupled heat pump system, however, is separated from the pressure of the household supply and relies on a small, low wattage pump to circulate the water and antifreeze solution through the earth coupling, heat pump and equipment room components.

The small circulator keeps the operating costs of the system to a minimum. However, the performance of the circulator MUST be closely matched with the pressure of head loss of the entire system in order to provide the required flow through the heat pump. Insufficient flow through the heat exchanger is one of the most common causes of system failure. Proper system piping design and circulator selection will eliminate this problem.

Bard supplies a work sheet to simplify heat loss calculations and circulator selection. Refer to “Circulating Pump Worksheet” section in manual 2100-099.

**FIGURE 6
CIRCULATION SYSTEM DESIGN**

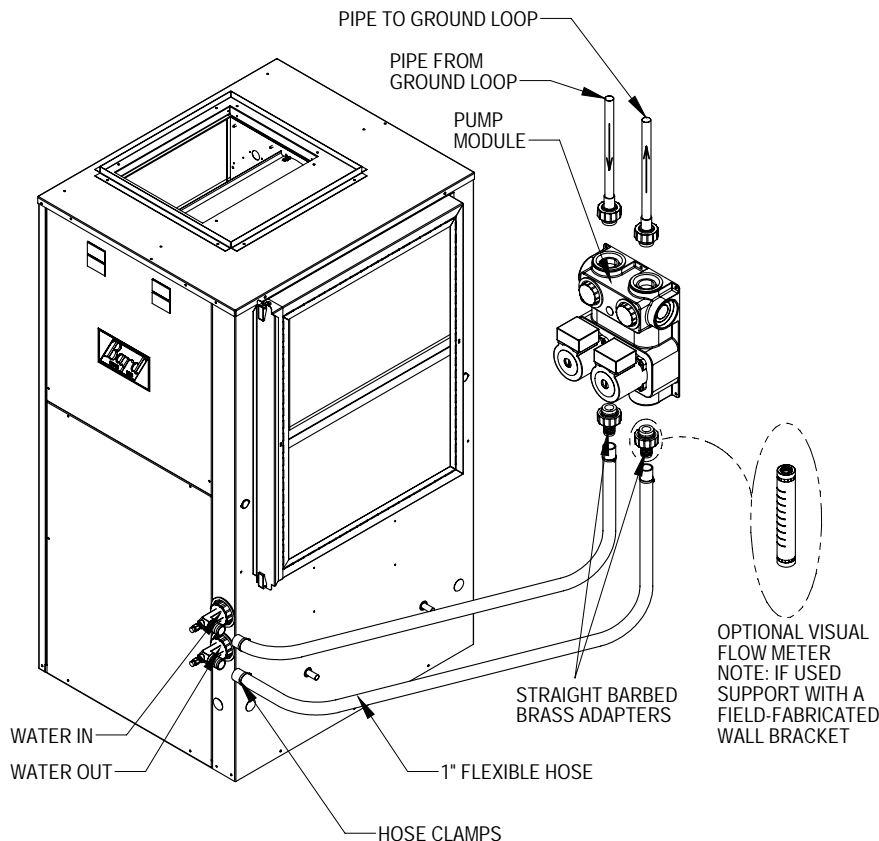

MIS-2621

START UP PROCEDURE FOR GROUND LOOP SYSTEM

1. Be sure main power to the unit is OFF at disconnect.
 2. Set thermostat system switch to OFF, fan switch to AUTO.
 3. Move main power disconnect to ON. Except as required for safety while servicing, *DO NOT OPEN THE UNIT DISCONNECT SWITCH.*
 4. Check system airflow for obstructions.
 - A. Move thermostat fan switch to ON. Blower runs.
 - B. Be sure all registers and grilles are open.
 - C. Move thermostat fan switch to AUTO. Blowing should stop.
 5. Flush, fill and pressurize the closed loop system as outlined in manual 2100-099.
 6. Fully open the manual inlet and outlet valves. Start the loop pump module circulator(s) and check for proper operation. If circulator(s) are not operating, turn off power and diagnose the problem.
 7. Check fluid flow using a direct reading flow meter or a single water pressure gauge, measure the pressure drop at the pressure/temperature plugs across the water coil. Compare the measurement with flow versus pressure drop table to determine the actual flow rate. If the flow rate is too low,
 8. Start the unit in cooling mode by moving the thermostat switch to cool. Fan should be set for AUTO.
 9. Check the system refrigerant pressures against the cooling refrigerant pressure table in the installation manual for rated water flow and entering water temperatures. If the refrigerant pressures do not match, check for airflow problem then refrigeration system problem.
 10. Switch the unit to the heating mode by moving the thermostat switch to heat. Fan should be set for AUTO.
 11. Check the refrigerant system pressures against the heating refrigerant pressure table in installation manual. Once again, if they do not match, check for airflow problems and then refrigeration system problems.
- NOTE:* If a charge problem is determined (high or low):
- A. Check for possible refrigerant leaks.
 - B. Recover all remaining refrigerant from unit and repair leak.
 - C. Evacuate unit down to 29 inches of vacuum.
 - D. Recharge the unit with refrigerant by weight. This is the only way to insure a proper charge.

FIGURE 7

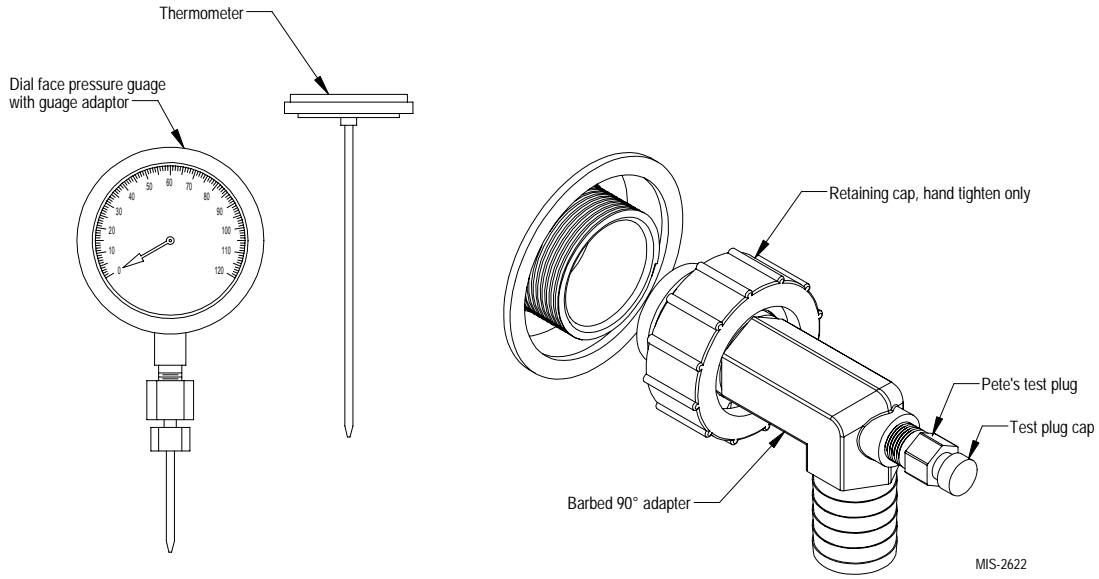

**FIGURE 8
PERFORMANCE MODEL DORFC-1 FLOW CENTER**

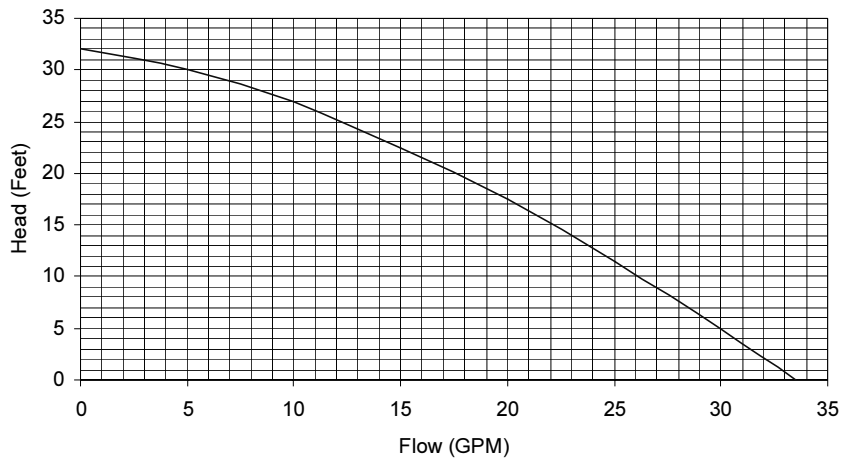

**FIGURE 9
PERFORMANCE MODEL DORFC-2 FLOW CENTER**

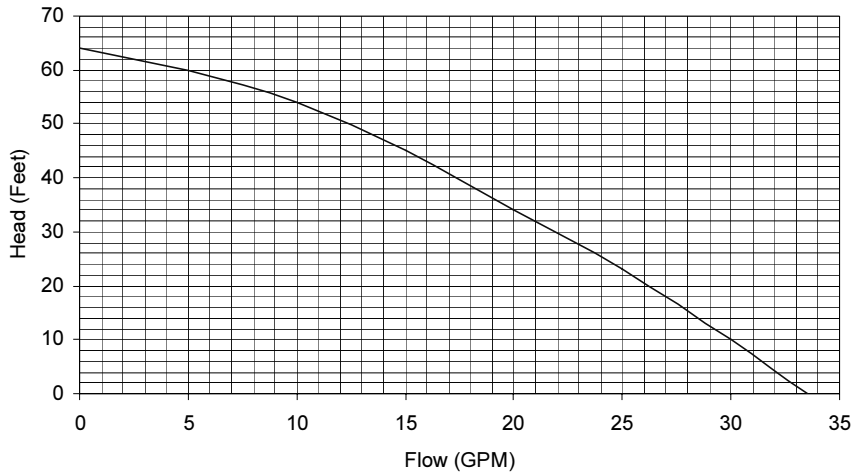

GROUND WATER (WELL SYSTEM APPLICATIONS)

NOTE:

Unit shipped from factory with 60 PSIG low pressure switch wired into control circuit for open loop applications.

WATER CONNECTIONS

It is very important that an adequate supply of clean, non-corrosive water at the proper pressure be provided before the installation is made. Insufficient water, in the heating mode for example, will cause the low pressure switch to trip, shutting down the heat pump. In assessing the capacity of the water system, it is advisable that the complete water system be evaluated to prevent possible lack of water or water pressure at various household fixtures whenever the heat pump turns on. All plumbing to and from the unit is to be installed in accordance with local plumbing codes. The use of plastic pipe, where permissible, is recommended to prevent electrolytic corrosion of the water pipe. Because of the relatively cold temperatures encountered with well water, it is strongly recommended that the water lines connecting the unit be insulated to prevent water droplets from condensing on the pipe surface.

Refer to piping, Figure 10. Slow open/close with **End Switch (2)**, 24V, provides on/off control of the water flow to the unit. Refer to the wiring diagram for correct hookup of the valve solenoid coil.

Constant Flow Valve (3) provides correct flow of water to the unit regardless of variations in water pressure. Observe the water flow direction indicated by the arrow on the side of the valve body. Following is a table showing which valve is to be installed with which heat pump.

**TABLE 8
CONSTANT FLOW VALVES**

Part No.	Min. Available Pressure PSIG	Flow Rate GPM
GFV-5	15 (1)	5
GFV-6	15 (1)	6
GFV-7	15 (1)	7
GFV-9	15 (1)	9
GFV-10	15 (1)	10

(1) The pressure drop through the constant flow valve will vary depending on the available pressure ahead of the valve. Unless minimum of 15 psig is available **immediately** ahead of the valve, no water will flow.

Strainer (8) installed upstream of **water coil inlet** to collect foreign material which would clog the flow valve orifice.

The figure shows the use of **shutoff valves (4)** and **(5)**, on the in and out water lines to permit isolation of the unit from the plumbing system should future service work require this. Globe valves should not be used as shutoff valves because of the excessive pressure drop inherent in the valve design. Instead use gate or ball valves as shutoffs, so as to minimize pressure drop.

Hose bib (6) and **(7)**, and tees should be included to permit acid cleaning the refrigerant-to-water coil should such cleaning be required. See WATER CORROSION.

Hose bib (1) provides access to the system to check water flow through the constant flow valve to insure adequate water flow through the unit. A water meter is used to check the water flow rate.

WELL PUMP SIZING

Strictly speaking, sizing the well pump is the responsibility of the well drilling contractor. It is important, however, that the HVAC contractor be familiar with the factors that determine what size pump will be required. Rule of thumb estimates will invariably lead to under or oversized well pumps. Undersizing the pump will result in inadequate water to the whole plumbing system, but with especially bad results to the heat pump – NO HEAT / NO COOL calls will result. Oversized pumps will short cycle and could cause premature pump motor or switch failures.

The well pump must be capable of supplying enough water and at an adequate pressure to meet competing demands of water fixtures. The well pump must be sized in such a way that three requirements are met:

1. Adequate flow rate in GPM.
2. Adequate pressure at the fixture.
3. Able to meet the above from the depth of the well-feet of lift.

The pressure requirements put on the pump are directly affected by the diameter of pipe being used, as well as, by the water flow rate through the pipe. The worksheet included in Manual 2100-078 should guarantee that the well pump has enough capacity. It should also ensure that

the piping is not undersized, which would create too much pressure due to friction loss. High pressure losses due to undersized pipe will reduce efficiency and require larger pumps and could also create water noise problems.

FIGURE 10
WATER CONNECTION COMPONENTS

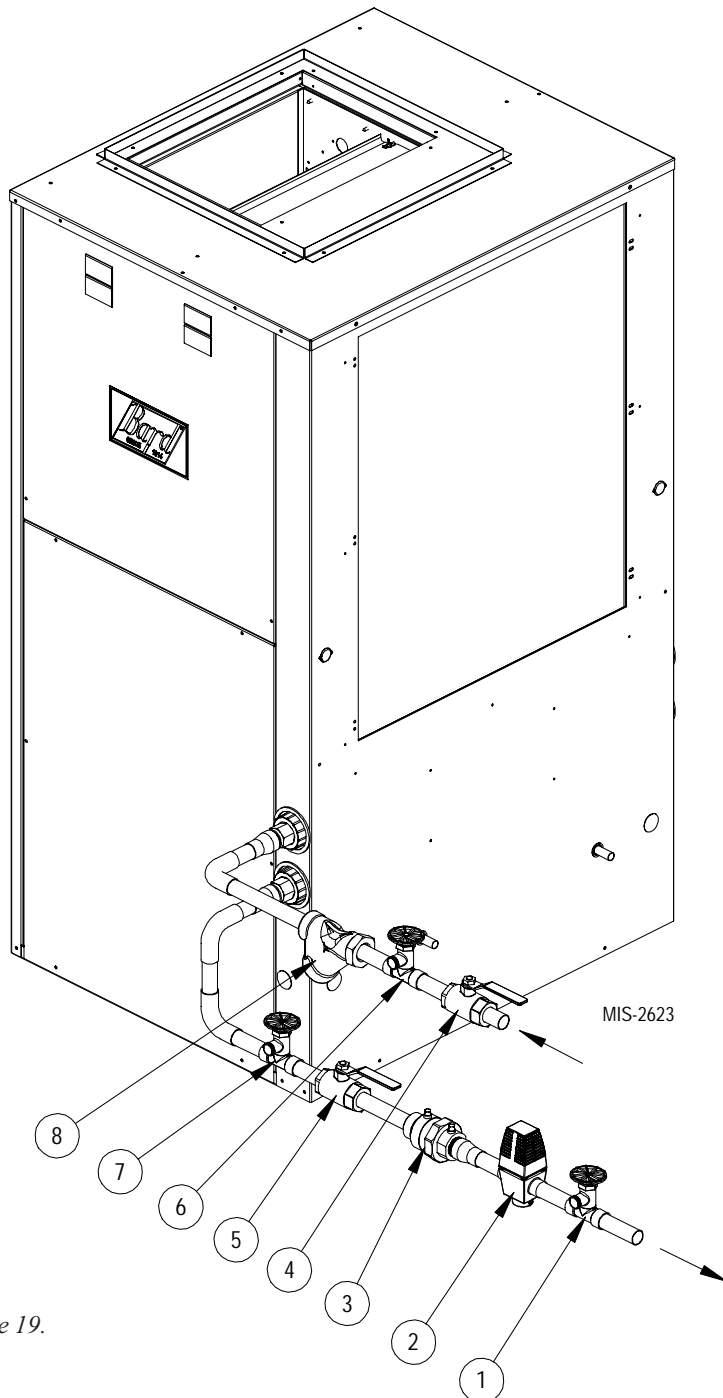

See descriptions for these reference numbers on Page 19.

SYSTEM START UP PROCEDURE FOR GROUND WATER APPLICATIONS

1. Be sure main power to the unit is OFF at disconnect.
2. Set thermostat system switch to OFF, fan switch to AUTO.
3. Move main power disconnect to ON. Except as required for safety while servicing – *DO NOT OPEN THE UNIT DISCONNECT SWITCH.*
4. Check system airflow for obstructions.
 - A. Move thermostat fan switch to ON. Blower runs.
 - B. Be sure all registers and grilles are open.
 - C. Move thermostat fan switch to AUTO. Blower should stop.
5. Fully open the manual inlet and outlet valves.
6. Check water flow.
 - A. Connect a water flow meter to the drain cock between the constant flow valve and the solenoid valve. Run a hose from the flow meter to a drain or sink. Open the drain cock.
 - B. Check the water flow rate through constant flow valve to be sure it is the same as the unit is rated for. (Example: 5 GPM for a GV27S1.)
 - C. When water flow is okay, close drain cock and remove the water flow meter. The unit is now ready to start.
7. Start the unit in cooling mode by moving the thermostat switch to cool. Fan should be set for AUTO.
 - A. Check to see the solenoid valve opened.
8. Check the system refrigerant pressures against the cooling refrigerant pressure table in the installation manual for rated water flow and entering water temperatures. If the refrigerant pressures do not match, check for airflow problem that refrigeration system problem.
9. Switch the unit to the heat mode by moving the thermostat switch to heat. Fan should be set for AUTO.
 - A. Check to see the solenoid valve opened again.
10. Check the refrigerant system pressures against the heating refrigerant pressure table in installation manual. Once again, if they do not match, check for airflow problems and then refrigeration system problems.

NOTE: If a charge problem is determined (high or low):

- A. Check for possible refrigerant loss.
- B. Discharge all remaining refrigerant from unit.
- C. Evacuate unit down to 29 inches of vacuum.
- D. Recharge the unit with refrigerant by weight. This is the only way to insure proper charge.

WATER CORROSION

Two concerns will immediately come to light when considering a water source heat pump, whether for ground water or for a ground loop application: Will there be enough water? And, how will the water quality affect the system?

Water quantity is an important consideration and one which is easily determined. The well driller must perform a pump down test on the well according to methods described by the National Well Water Association. This test, if performed correctly, will provide information on the rate of flow and on the capacity of the well. It is important to consider the overall capacity of the well when thinking about a water source heat pump because the heat pump may be required to run for extended periods of time.

The second concern, about water quality, is equally important. Generally speaking, if the water is not offensive for drinking purposes, it should pose no problem for the heat pump. The well driller or local water softening company can perform tests which will determine the chemical properties of the well water.

Water quality problems will show up in the heat pump in one or more of the following ways:

1. Decrease in water flow through the unit.
2. Decreased heat transfer of the water coil (entering to leaving water temperature difference is less).

There are four main water quality problems associated with ground water. These are:

1. **Biological Growth.** This is the growth of microscopic organisms in the water and will show up as a slimy deposit throughout the water system. Shock treatment of the well is usually required and this is best left up to the well driller. The treatment consists of injecting chlorine into the well casing and flushing the system until all growth is removed.
2. **Suspended Particles in the Water.** Filtering will usually remove most suspended particles (fine sand, small gravel) from the water. The problem with suspended particles in the water is that it will erode metal parts, pumps, heat transfer coils, etc. So long as the filter is cleaned and periodically maintained, suspended particles should pose no serious problem. Consult with your well driller.
3. **Corrosion of Metal.** Corrosion of metal parts results from either highly corrosive water (acid water, generally not the case with ground water) or galvanic reaction between dissimilar metals in the presence of water. By using plastic plumbing or dielectric unions, galvanic reaction is eliminated. The use of corrosion resistant materials such as the Cupronickel coil through the water system will reduce corrosion problems significantly.

4. **Scale Formation.** Of all the water problems, the formation of scale by ground water is by far the most common. Usually this scale is due to the formation of calcium carbonate but magnesium carbonate or calcium sulfate may also be present. Carbon dioxide gas (CO₂), the carbonate of calcium and magnesium carbonate, is very soluble in water. It will remain dissolved in the water until some outside factor upsets the balance. This outside influence may be a large change in water temperature or pressure. When this happens, enough carbon dioxide gas combines with dissolved calcium or magnesium in the water and falls out of solution until a new balance is reached. The change in temperature that this heat pump produces is usually not high enough to cause the dissolved gas to fall out of solution. Likewise, if pressure drops are kept to a reasonable level, no precipitation of carbon dioxide should occur.

REMEDIES OF WATER PROBLEMS

Water Treatment. Water treatment can usually be economically justified for water loop systems. However, because of the large amounts of water involved with a ground water system, water treatment is generally too expensive.

Acid Cleaning the Water Coil or Heat Pump Recovery Unit. If scaling of the coil is strongly suspected, the coil can be cleaned up with a solution of Phosphoric Acid (food grade acid). Follow the manufacturer's directions for mixing, use, etc. Refer to the "Cleaning Water Coil", Figure 11. The acid solution can be introduced into the heat pump coil through the hose bib A. Be sure the isolation valves are closed to prevent contamination of the rest of the system by the coil. The acid should be pumped from a bucket into the hose bib and returned to the bucket through the other hose bib B. Follow the manufacturer's directions for the product used as to how long the solution is to be circulated, but it is usually circulated for a period of several hours.

LAKE AND POND INSTALLATIONS

Lakes and ponds can provide a low cost source of water for heating and cooling with a ground water heat pump. Direct usage of the water without some filtration is not recommended as algae and turbid water can foul the water to refrigerant heat exchanger. Instead, there have been very good results using a dry well dug next to the water line or edge. Normal procedure in installing a dry well is to backhoe a 15 to 20 foot hole adjacent to the body of water (set backhoe as close to the water's edge as possible). Once excavated, a perforated plastic casing should be installed with gravel backfill placed around the casing. The gravel bed should provide adequate filtration of the water to allow good performance of the ground water heat pump.

The following is a list of recommendations to follow when installing this type of system:

- A lake or pond should be at least 1 acre (40,000 a square feet) in surface area for each 50,000 BTUs of ground water heat pump capacity or have 2 times the cubic feet size of the dwelling that you are trying to heat (includes basement if heated).
- The average water depth should be at least 4 feet and there should be an area where the water depth is at least 12 to 15 feet deep.

**FIGURE 11
CLEANING WATER COIL**

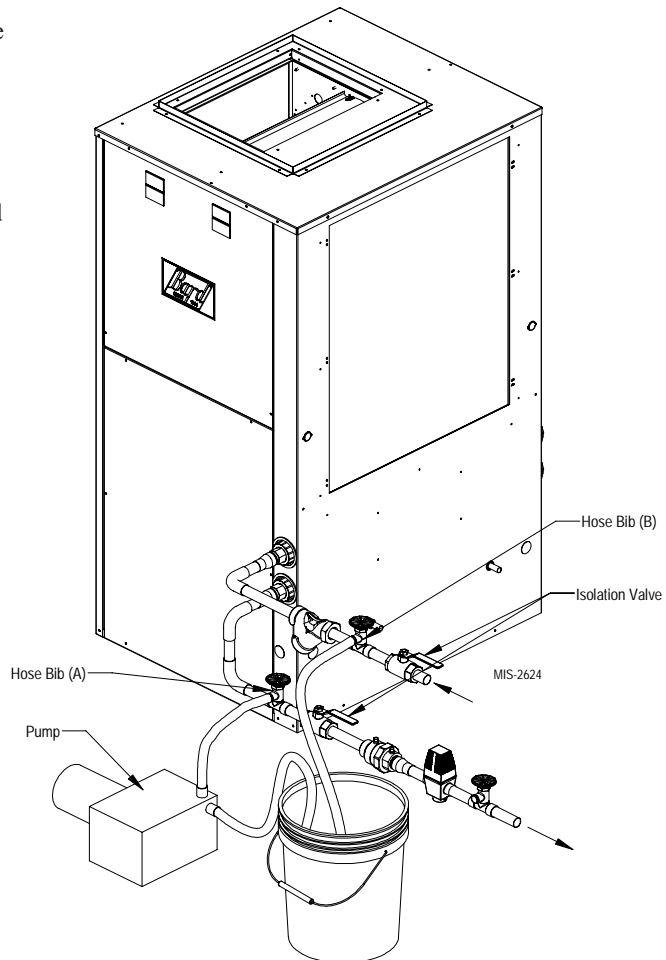

- C. If possible, use a submersible pump suspended in the dry well casing. Jet pumps and other types of suction pumps normally consume more electrical energy than similarly sized submersible pumps. Pipe the unit the same as a water well system.
- D. Size the pump to provide necessary GPM for the ground water heat pump. A 12 GPM or greater water flow rate is required on all models when used on this type system.
- E. A pressure tank should be installed in dwelling to be heated adjacent to the ground water heat pump. A pressure switch should be installed at the tank for pump control.
- F. All plumbing should be carefully sized to compensate for friction losses, etc., particularly if the pond or lake is over 200 feet from the dwelling to be heated or cooled.
- G. Keep all water lines below low water level and below the frost line.
- H. Most installers use 4-inch field tile (rigid plastic or corrugated) for water return to the lake or pond.
- I. The drain line discharge should be located at least 100 feet from the dry well location.
- J. The drain line should be installed with a slope of 2 inches per 10 feet of run to provide complete drainage of the line when the ground water heat pump is not operating. This gradient should also help prevent freezing of the discharge where the pipe terminates above the frost line.
- K. Locate the discharge high enough above high water level so the water will not back up and freeze inside the drain pipe.
- L. Where the local conditions prevent the use of a gravity drainage system to a lake or pond, you can instead run standard plastic piping out into the pond below the frost and low water level.

	<h1 style="margin: 0;">WARNING</h1>
<p>Thin ice may result in the vicinity of the discharge line.</p>	

For complete information on water well systems and lake and pond applications, refer to Manual 2100-078 available from your distributor.

**FIGURE 12
LAKE OR POND INSTALLATION**

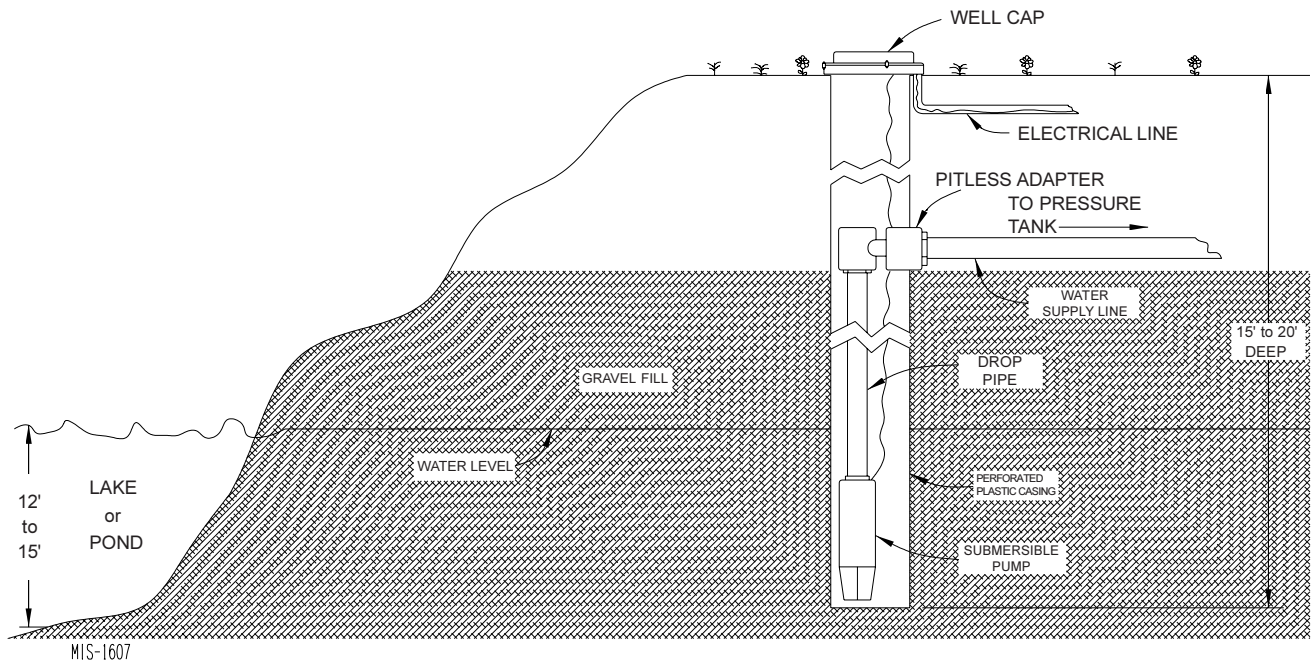

SEQUENCE OF OPERATION

BLOWER

Blower functions are all automatic through the thermostat control. (See Table 1 for the specific airflows on each speed.) Motor control inputs are all 24 VAC with line power to motor being continuous.

On a call for “G” from the thermostat (*call for manual fan*), speed tap #1 on the blower motor is energized.

On a call for “Y1” from the thermostat (heating or cooling), speed tap #2 of the blower motor is energized immediately. Simultaneously, the “Y1” tap of the blower control board is also energized, and following 5 minutes, the blower control will power speed tap #3 of the blower motor.

On a call for “Y2” operation from the thermostat (heating or cooling), speed tap #5 will be energized through the blower control board. *The exception is a jumper pin connection on the blower control board. It comes from the factory by default jumpering Pins #4 and #5 together to run the blower at nominal rated full load airflow. If this is too noisy, this jumper can be removed from Pins #4/#5 to allow the full load airflow to be reduced by 10% (see Unit Wiring Diagram).*

On any call for “W” (electric heat operation), from the thermostat, speed tap #5 is always energized. (It is not affected by the #4/#5 jumper on the blower control board.)

PART LOAD COOLING

When thermostat system switch is placed in COOL, it completes a circuit from “R” to “O”, energizing the reversing valve solenoid. On a call for cooling, the thermostat completes a circuit from “R” to “Y1”, which energizes the compressor contactor and blower motor on speed tap #2 initially, then speed tap #3 after 5 minutes (see BLOWER above).

FULL LOAD COOLING

The system should already be in Part Load Cooling operation prior to Full Load Cooling being energized. Additionally what happens, the thermostat completes a circuit from “R” to “Y2”. This sends a signal to both the staging solenoid on the side of the compressor and energizes either tap #5 (or tap #4) of the blower motor (see BLOWER above).

PART LOAD HEATING (No Electric Heat)

When thermostat system switch is placed in HEAT, the reversing valve solenoid is no longer energized. On a call for part load heating, the thermostat completes a circuit from “R” to “Y1”, which energizes the compressor contactor and blower motor on speed tap #2 initially, then speed tap #3 after 5 minutes (see BLOWER above).

FULL LOAD HEATING (No Electric Heat)

The system should already be in Part Load Heating operation prior to Full Load Heating being energized. Additionally what happens, the thermostat completes a circuit from “R” to “Y2”. This sends a signal to both the staging solenoid on the side of the compressor and energizes either tap #5 or tap #4 of the blower motor (see BLOWER above).

SUPPLEMENTARY ELECTRIC HEAT

The system should already be in FULL LOAD HEATING operation (above). The thermostat completes a circuit from “R” to “W2”, which energizes up to 9 KW of electric heat (depends on heater package installed). 9 KW of electric heat is the limit when operating with the heat pump and is controlled through the emergency heat relay.

EMERGENCY HEAT MODE

When thermostat system switch is placed in EMERGENCY HEAT MODE and the thermostat calls for heat, it completes a circuit from “R” to “E” and from “R” to “W2”. This will energize the heater package for all available KW per the installed heater package. (*The call from “R” to “E” locks out compressor operation.*) The blower motor is automatically energized with this function and will run on speed #5 (see BLOWER above).

SEQUENCE OF OPERATION

COMPRESSOR CONTROL MODULE

The compressor control module is an anti-short cycle/lockout timer with high and low pressure switch monitoring and alarm output.

ADJUSTABLE DELAY ON MAKE AND BREAK TIMER

On a call for compressor operation the *delay on make* period begins, which will be 10% of the *delay on break* setting. When the delay on make is complete and the high pressure switch and low pressure switch are closed, the compressor contactor is energized. Upon shutdown, the delay on break timer starts and prevents restart until the delay on break and delay on make periods have expired.

HIGH PRESSURE SWITCH AND LOCKOUT SEQUENCE (Standard Feature)

If the high pressure switch opens, the compressor contactor will de-energize immediately. The lockout timer will go into a *soft lockout* and stay in soft lockout until the high pressure switch closes **and** the delay on make time has expired. If the high pressure switch opens again in the same operating cycle, the unit will go into *manual lockout* condition and the alarm relay circuit will energize. Recycling the wall thermostat resets the manual lockout.

LOW PRESSURE SWITCH, BYPASS AND LOCKOUT SEQUENCE (Standard Feature)

If the low pressure switch opens for more than 120 seconds, the compressor contactor will de-energize and go into a soft lockout. Regardless the state of the low pressure switch, the contactor will reenergize after the delay on make time delay has expired. If the low pressure switch remains open, or opens again for longer than 120 seconds in the same operating cycle, the unit will go into manual lockout condition and the alarm relay circuit will energize. Recycling the wall thermostat resets the manual lockout.

ALARM OUTPUT

Alarm terminal is output connection for applications where alarm signal is desired. This terminal is powered whenever compressor is locked out due to HPC or LPC sequences as described.

Note: Both high and low pressure switch controls are inherently automatic reset devices. The high pressure switch and low pressure switch cut out and cut in settings are fixed by specific air conditioner or heat pump unit model. The lockout feature, both soft and manual, are a function of the Compressor Control Module.

PRESSURE SERVICE PORTS

High and low pressure service ports are installed on all units so that the system operating pressures can be observed. Pressure tables can be found later in the manual covering all models. It is imperative to match the correct pressure table to the unit by model number.

SYSTEM START-UP

- Step 1 – Close disconnect switch(es) and set the thermostat to cool and the temperature to the highest setting.
- Step 2 – Check for proper airflow across the indoor coil.
- Step 3 – Connect the service gauges and allow the unit to run for at least 10 minutes or until pressures are stable. Check pressures to the system pressure table attached to the unit service panel.
- Step 4 – Fill out Ground Source Heat Pump Performance Report.

**FIGURE 13
COMPONENT LOCATION**

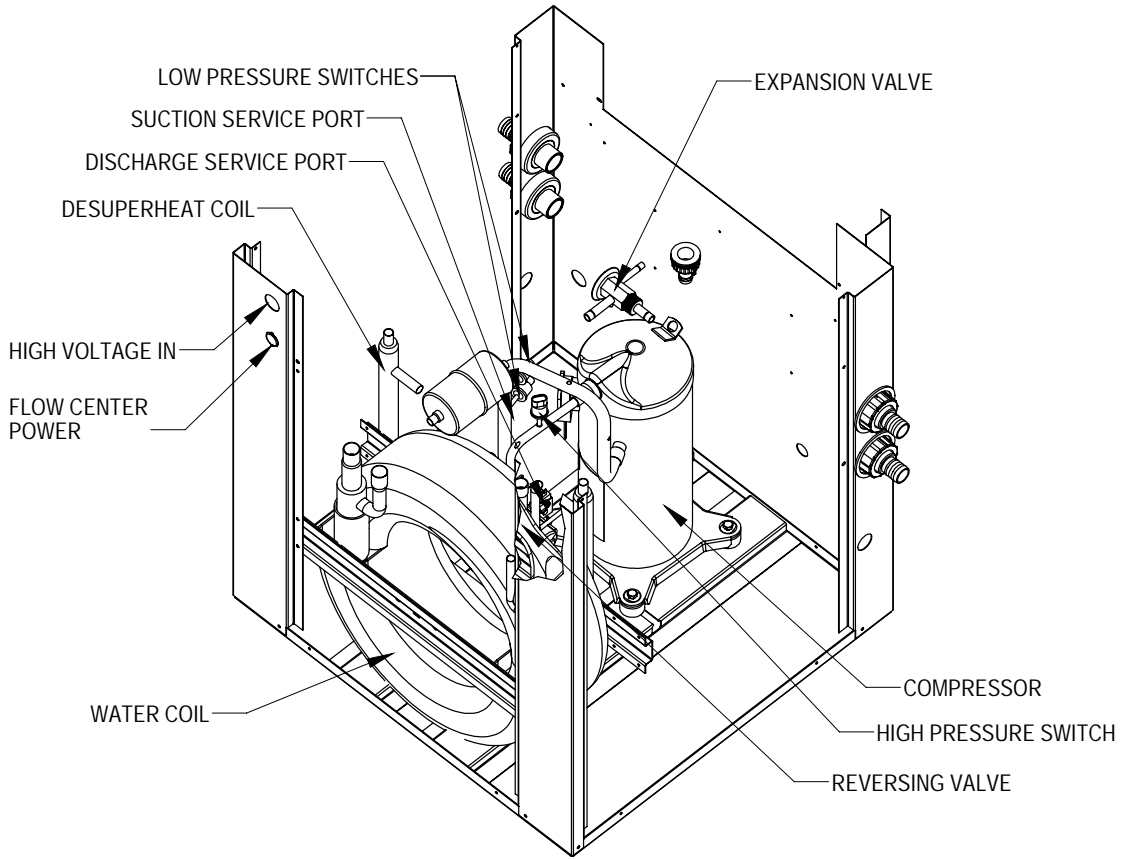

MIS-2625

**FIGURE 14
CONTROL PANEL**

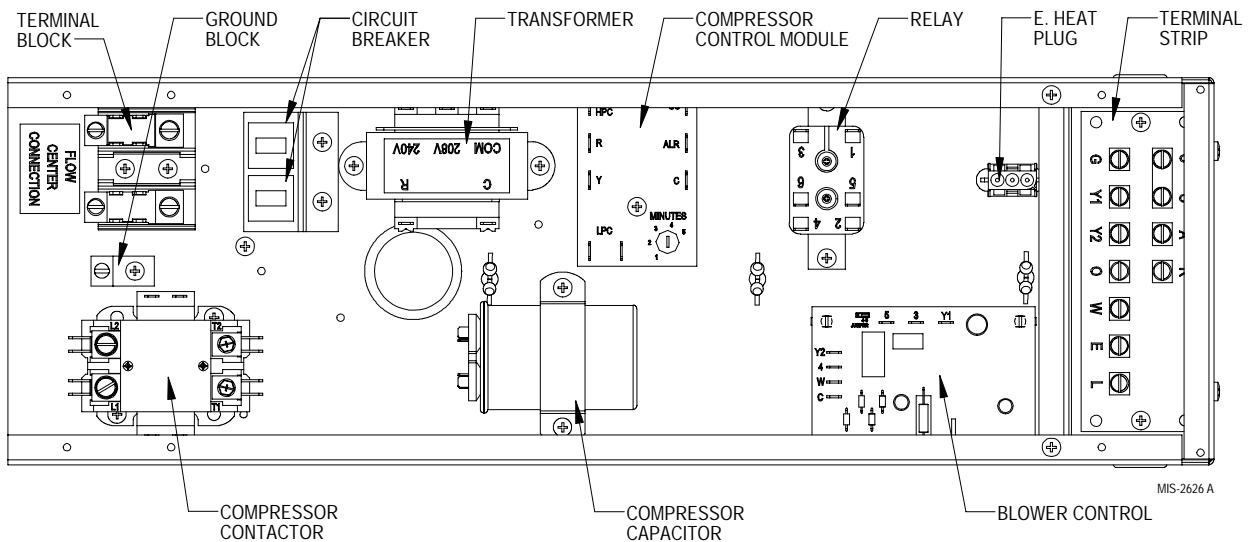

MIS-2626 A

FIGURE 15

COOLING CYCLE

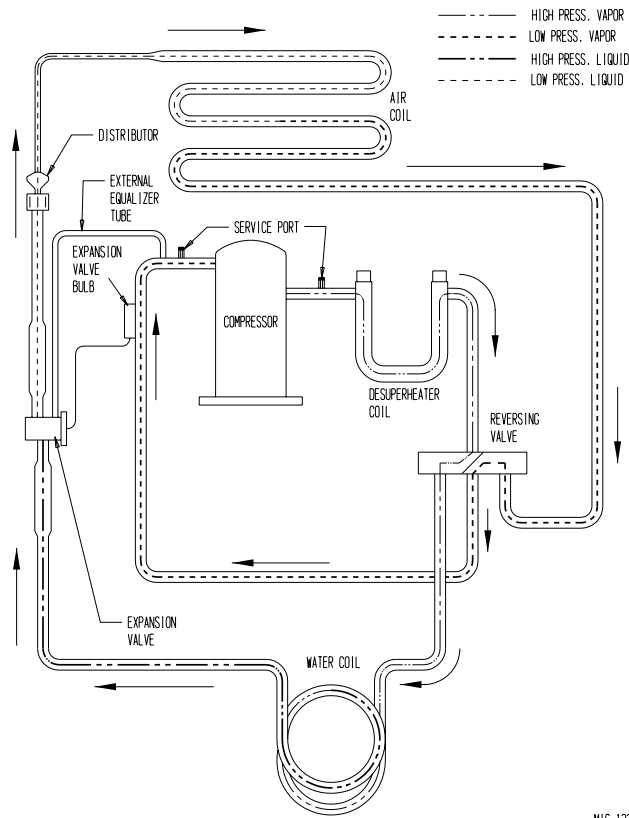

MIS-1229

HEATING CYCLE

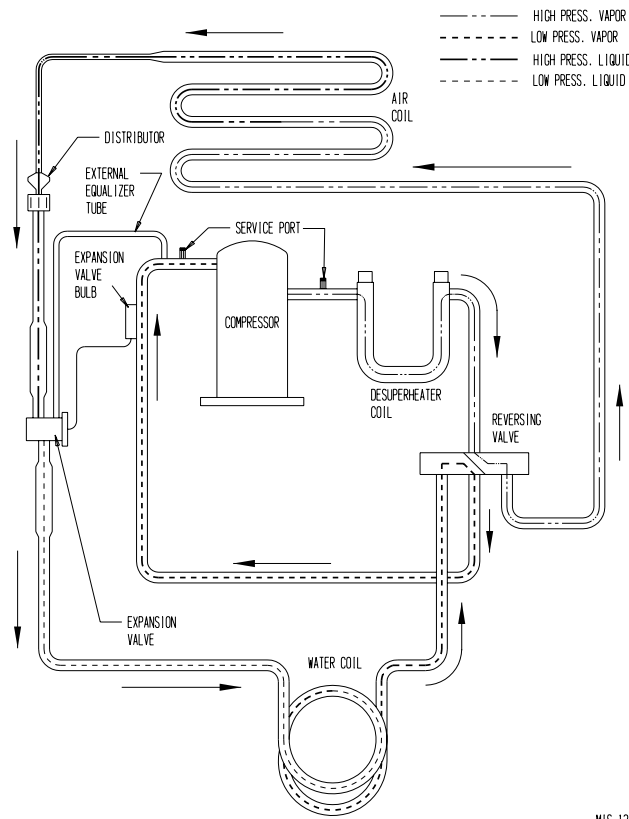

MIS-1228

**FIGURE 16A
PRESSURE TABLES**

FULL LOAD COOLING — Fluid Temperature Entering Water Coil °F																			
Model	Return Air Temperature	Pressure	30°F	35°F	40°F	45°F	50°F	55°F	60°F	65°F	70°F	75°F	80°F	85°F	90°F	95°F	100°F	105°F	110°F
			GV27S1	75° DB 62° WB	Low Side High Side	111 135	115 150	118 165	121 180	124 195	128 210	131 224	134 239	137 254	138 275	139 296	140 317	141 338	142 358
GV38S1	80° DB 67° WB	Low Side High Side	119 138	123 153	126 169	130 184	133 200	137 215	140 230	144 246	147 261	148 282	149 304	150 325	151 346	152 368	153 389	154 410	155 432
	85° DB 72° WB	Low Side High Side	128 143	132 159	135 175	139 191	143 206	147 222	151 238	154 254	158 270	159 292	160 314	161 336	162 358	163 381	164 403	166 425	167 447
	75° DB 62° WB	Low Side High Side	101 145	104 160	108 175	111 189	115 204	118 218	121 233	125 248	128 262	129 283	131 304	132 324	133 345	134 365	135 386	137 407	138 427
	80° DB 67° WB	Low Side High Side	108 149	112 164	115 179	119 194	123 209	126 224	130 239	133 254	137 269	139 290	140 311	142 333	144 354	145 375	146 396	148 417	149 438
GV38S1	85° DB 72° WB	Low Side High Side	116 154	120 170	124 185	128 201	132 216	136 232	139 247	143 263	147 278	149 300	151 322	152 344	154 366	155 388	157 410	159 432	160 454
	Return Air Temperature	Pressure	5°F	10°F	15°F	20°F	25°F	30°F	35°F	40°F	45°F	50°F	55°F	60°F	65°F	70°F	75°F	80°F	85°F
GV27S1	70° DB	Low Side High Side	41 257	49 265	58 274	66 282	75 291	83 299	92 308	100 316	109 325	117 333	125 343	134 353	142 363	150 373	158 383	167 393	175 403
GV38S1	70° DB	Low Side High Side	52 215	58 228	64 241	70 255	75 268	81 281	87 294	93 308	98 321	104 334	112 343	121 352	129 361	137 370	145 379	154 388	162 397
FULL LOAD HEATING — Fluid Temperature Entering Water Coil °F																			
Model	Return Air Temperature	Pressure	5°F	10°F	15°F	20°F	25°F	30°F	35°F	40°F	45°F	50°F	55°F	60°F	65°F	70°F	75°F	80°F	85°F
			GV27S1	75° DB 62° WB	Low Side High Side	104 114	109 130	113 146	118 161	123 177	128 193	133 208	137 224	142 240	144 260	145 280	146 301	147 321	148 341
GV27S1	80° DB 67° WB	Low Side High Side	111 117	116 133	121 149	126 165	132 182	137 198	142 214	147 230	152 246	153 267	154 288	155 309	156 329	157 350	158 371	159 392	160 413
	85° DB 72° WB	Low Side High Side	119 121	125 138	130 154	136 171	141 188	147 205	152 221	158 238	163 255	164 276	166 298	167 319	168 341	169 362	170 384	171 406	172 427
	75° DB 62° WB	Low Side High Side	104 126	108 140	112 155	116 169	120 184	124 198	128 213	132 227	137 242	138 262	139 282	140 302	141 322	143 343	144 363	145 383	146 403
	80° DB 67° WB	Low Side High Side	111 129	115 144	120 159	124 174	129 189	133 203	137 218	142 233	146 248	147 269	149 289	150 310	151 331	153 351	154 372	155 393	157 413
GV38S1	85° DB 72° WB	Low Side High Side	119 134	124 149	129 164	133 180	138 195	143 210	148 226	152 241	157 257	158 278	160 299	161 321	163 342	164 364	166 385	167 406	168 428
	Return Air Temperature	Pressure	5°F	10°F	15°F	20°F	25°F	30°F	35°F	40°F	45°F	50°F	55°F	60°F	65°F	70°F	75°F	80°F	85°F
GV27S1	70° DB	Low Side High Side	41 251	50 258	59 265	68 273	77 280	86 287	95 294	104 302	113 309	122 316	131 325	140 334	149 342	158 351	167 360	176 369	185 377
GV38S1	70° DB	Low Side High Side	47 254	54 261	62 269	69 276	77 284	84 291	92 299	99 306	107 314	114 321	123 329	131 337	140 345	148 353	157 361	165 369	174 377
PART LOAD COOLING — Fluid Temperature Entering Water Coil °F																			
Model	Return Air Temperature	Pressure	30°F	35°F	40°F	45°F	50°F	55°F	60°F	65°F	70°F	75°F	80°F	85°F	90°F	95°F	100°F	105°F	110°F
			GV27S1	75° DB 62° WB	Low Side High Side	104 114	109 130	113 146	118 161	123 177	128 193	133 208	137 224	142 240	144 260	145 280	146 301	147 321	148 341
GV27S1	80° DB 67° WB	Low Side High Side	111 117	116 133	121 149	126 165	132 182	137 198	142 214	147 230	152 246	153 267	154 288	155 309	156 329	157 350	158 371	159 392	160 413
	85° DB 72° WB	Low Side High Side	119 121	125 138	130 154	136 171	141 188	147 205	152 221	158 238	163 255	164 276	166 298	167 319	168 341	169 362	170 384	171 406	172 427
	75° DB 62° WB	Low Side High Side	104 126	108 140	112 155	116 169	120 184	124 198	128 213	132 227	137 242	138 262	139 282	140 302	141 322	143 343	144 363	145 383	146 403
	80° DB 67° WB	Low Side High Side	111 129	115 144	120 159	124 174	129 189	133 203	137 218	142 233	146 248	147 269	149 289	150 310	151 331	153 351	154 372	155 393	157 413
GV38S1	85° DB 72° WB	Low Side High Side	119 134	124 149	129 164	133 180	138 195	143 210	148 226	152 241	157 257	158 278	160 299	161 321	163 342	164 364	166 385	167 406	168 428
	Return Air Temperature	Pressure	5°F	10°F	15°F	20°F	25°F	30°F	35°F	40°F	45°F	50°F	55°F	60°F	65°F	70°F	75°F	80°F	85°F
GV27S1	70° DB	Low Side High Side	41 251	50 258	59 265	68 273	77 280	86 287	95 294	104 302	113 309	122 316	131 325	140 334	149 342	158 351	167 360	176 369	185 377
GV38S1	70° DB	Low Side High Side	47 254	54 261	62 269	69 276	77 284	84 291	92 299	99 306	107 314	114 321	123 329	131 337	140 345	148 353	157 361	165 369	174 377

**FIGURE 16B
PRESSURE TABLES**

Model	Return Air Temperature	Pressure	FULL LOAD COOLING — Fluid Temperature Entering Water Coil °F																
			30°F	35°F	40°F	45°F	50°F	55°F	60°F	65°F	70°F	75°F	80°F	85°F	90°F	95°F	100°F	105°F	110°F
GV51S1	75° DB	Low Side	104	106	109	112	115	117	120	123	125	127	128	129	130	132	133	134	135
	62° WB	High Side	141	157	173	189	205	221	236	252	268	289	309	330	351	371	392	413	433
	80° DB	Low Side	111	114	117	120	123	125	128	131	134	135	137	138	139	141	142	143	145
	67° WB	High Side	145	161	178	194	210	226	243	259	275	296	317	339	360	381	402	423	444
GV61S1	85° DB	Low Side	119	122	126	129	132	135	138	141	144	145	147	148	150	151	153	154	156
	72° WB	High Side	150	167	184	201	217	234	251	268	285	307	328	350	372	394	416	438	460
	75° DB	Low Side	108	110	112	114	116	118	120	122	123	125	126	127	128	130	131	132	133
	62° WB	High Side	143	160	176	192	208	224	241	257	273	293	314	334	354	375	395	415	436
GV71S1	80° DB	Low Side	116	118	120	122	124	126	128	130	132	133	135	136	137	139	140	141	143
	67° WB	High Side	147	164	180	197	214	230	247	263	280	301	322	343	363	384	405	426	447
	85° DB	Low Side	125	127	129	131	133	135	138	140	142	143	145	146	148	149	151	152	153
	72° WB	High Side	152	169	187	204	221	238	255	273	290	311	333	354	376	398	419	441	462
GV71S1	75° DB	Low Side	110	111	112	113	115	116	117	118	119	119	119	120	120	121	121	121	121
	62° WB	High Side	175	186	197	209	220	231	243	254	265	286	307	328	348	369	390	411	432
	80° DB	Low Side	118	119	120	121	123	124	125	126	127	127	128	128	128	129	129	129	130
	67° WB	High Side	179	191	202	214	226	237	249	260	272	293	315	336	357	379	400	421	443
GV71S1	85° DB	Low Side	127	128	129	130	132	133	134	135	137	137	137	138	138	138	139	139	139
	72° WB	High Side	185	197	209	221	233	245	257	269	282	304	326	348	370	392	414	436	458

Model	Return Air Temperature	Pressure	FULL LOAD HEATING — Fluid Temperature Entering Water Coil °F																
			5°F	10°F	15°F	20°F	25°F	30°F	35°F	40°F	45°F	50°F	55°F	60°F	65°F	70°F	75°F	80°F	85°F
GV51S1	70° DB	Low Side	34	42	50	58	65	73	81	89	96	104	113	123	132	141	150	160	169
		High Side	273	282	291	300	308	317	326	335	343	352	363	374	385	396	407	418	429
GV61S1	70° DB	Low Side	37	45	53	61	69	77	85	93	101	109	118	127	136	145	154	163	172
		High Side	272	283	294	305	315	326	337	348	358	369	382	395	408	421	434	447	460
GV71S1	70° DB	Low Side	38	45	52	59	66	73	80	87	94	101	111	121	131	141	151	161	171
		High Side	259	268	278	287	297	306	316	325	335	344	355	366	376	387	398	409	419

Model	Return Air Temperature	Pressure	PART LOAD COOLING — Fluid Temperature Entering Water Coil °F																
			30°F	35°F	40°F	45°F	50°F	55°F	60°F	65°F	70°F	75°F	80°F	85°F	90°F	95°F	100°F	105°F	110°F
GV51S1	75° DB	Low Side	106	109	112	115	119	122	125	129	132	133	135	136	137	139	140	142	143
	62° WB	High Side	127	142	157	172	187	202	217	233	248	268	288	308	328	348	369	389	409
	80° DB	Low Side	113	117	120	124	127	131	134	138	141	143	144	146	147	149	150	152	153
	67° WB	High Side	130	146	161	177	192	208	223	239	254	275	295	316	337	357	378	399	419
GV61S1	85° DB	Low Side	121	125	129	133	137	140	144	148	152	153	155	156	158	160	161	163	164
	72° WB	High Side	135	151	167	183	199	215	231	247	263	284	306	327	348	370	391	413	434
	75° DB	Low Side	108	111	114	117	120	123	126	129	132	133	134	135	136	137	138	139	141
	62° WB	High Side	136	150	165	179	194	209	223	238	253	273	293	312	332	352	372	392	412
GV71S1	80° DB	Low Side	115	118	122	125	128	131	135	138	141	142	143	145	146	147	148	149	150
	67° WB	High Side	139	154	169	184	199	214	229	244	259	280	300	321	341	362	382	403	423
	85° DB	Low Side	124	127	131	134	138	141	145	148	152	153	154	155	157	158	159	160	162
	72° WB	High Side	144	159	175	190	206	221	237	253	268	289	311	332	353	374	395	417	438
GV71S1	75° DB	Low Side	108	111	113	115	117	119	121	123	125	127	128	129	130	132	133	134	135
	62° WB	High Side	139	153	167	181	195	209	223	237	251	271	291	312	332	352	372	393	413
	80° DB	Low Side	116	118	121	123	125	127	130	132	134	135	137	138	139	141	142	143	145
	67° WB	High Side	143	157	172	186	200	214	229	243	257	278	299	320	340	361	382	403	424
GV71S1	85° DB	Low Side	125	127	130	132	134	137	139	142	144	145	147	148	150	151	153	154	156
	72° WB	High Side	148	163	178	192	207	222	236	251	266	288	309	331	352	374	395	417	438

Model	Return Air Temperature	Pressure	PART LOAD HEATING — Fluid Temperature Entering Water Coil °F																
			5°F	10°F	15°F	20°F	25°F	30°F	35°F	40°F	45°F	50°F	55°F	60°F	65°F	70°F	75°F	80°F	85°F
GV51S1	70° DB	Low Side	41	49	57	65	73	81	89	97	105	113	123	132	142	151	161	170	180
		High Side	256	264	273	281	290	298	307	315	324	332	342	351	361	370	380	389	399
GV61S1	70° DB	Low Side	41	49	58	66	75	83	92	100	109	117	126	135	144	153	162	171	180
		High Side	251	261	271	281	291	301	311	321	331	341	351	362	372	382	392	403	413
GV71S1	70° DB	Low Side	39	47	55	64	72	80	88	97	105	113	123	132	142	151	161	170	180
		High Side	249	258	267	277	286	295	304	314	323	332	341	351	360	369	378	388	397

LOW SIDE PRESSURE +/- 2 PSIG

HIGH SIDE PRESSURE +/- 5 PSIG

Tables based upon rated CFM (airflow) across the evaporator coil.

If incorrect charge suspected (more than ±2 psig suction, ±5 psig liquid), it is recommended refrigerant charge be reclaimed, system evacuated and charged to serial plate quantity.

SERVICE HINTS

1. Caution owner to maintain clean air filters at all times. Also, not to needlessly close off supply and return air registers. This reduces airflow through the system, which shortens equipment service life as well as increasing operating costs.
2. Check all power fuses or circuit breakers to be sure that they are the correct rating.

UNBRAZING SYSTEM COMPONENTS

If the refrigerant charge is removed from a scroll equipped unit by bleeding the high side only, it is sometimes possible for the scrolls to seal, preventing pressure equalization through the compressor. This may leave low side shell and suction line tubing pressurized. If the brazing torch is then applied to the low side while the low side shell and suction line contains pressure, the pressurized refrigerant and oil mixture could ignite when it escapes and contacts the brazing flame. To prevent this occurrence, it is important to check both the high and low side with manifold gauges before unbrazing.

This unit is equipped with an ECM motor. It is important that the blower motor plugs are not plugged in or unplugged while the power is on. Failure to remove power prior to unplugging or plugging in the motor could result in motor failure.



WARNING

Both the high and low side of the scroll compressor must be checked with manifold gauges before unbrazing system components. Failure to do so could cause pressurized refrigerant and oil mixture to ignite if it escapes and contacts the brazing flame causing property damage, bodily harm or death.



CAUTION

Do not plug in or unplug blower motor connectors while the power is on. Failure to do so may result in motor failure.

COMPRESSOR SOLENOID

(See Sequence of Operation on Pages 24 & 25 for function.)

A nominal 24-volt direct current coil activates the internal compressor solenoid. The input control circuit voltage must be 18 to 28 volt ac. The coil power requirement is 20 VA. The external electrical connection is made with a molded plug assembly. This plug contains a full wave rectifier to supply direct current to the unloader coil.

Compressor Solenoid Test Procedure – If it is suspected that the unloader is not working, the following methods may be used to verify operation.

1. Operate the system and measure compressor amperage. Cycle the compressor solenoid on and off at 10-second intervals. The compressor amperage should go up or down at least 25 percent.
2. If step one does not give the expected results, shut unit off. Apply 18 to 28 volt ac to the solenoid molded plug leads and listen for a click as the solenoid pulls in. Remove power and listen for another click as the solenoid returns to its original position.
3. If clicks can't be heard, shut off power and remove the control circuit molded plug from the compressor and measure the solenoid coil resistance. The resistance should be 32 to 60 ohms depending on compressor temperature.
4. Next, check the molded plug.

Voltage check: Apply control voltage to the plug wires (18 to 28 volt ac). The measured **dc** voltage at the female connectors in the plug should be around 15 to 27 vdc.

Resistance check: Measure the resistance from the end of one molded plug lead to either of the two female connectors in the plug. One of the connectors should read close to zero ohms, while the other should read infinity. Repeat with other wire. The same female connector as before should read zero, while the other connector again reads infinity. Reverse polarity on the ohmmeter leads and repeat. The female connector that read infinity previously should now read close to zero ohms.

Replace plug if either of these test methods does not show the desired results.

TROUBLESHOOTING GE X13-SERIES ECM MOTORS

If the Motor is Running

1. It is normal for the motor to rock back and forth on start up. Do not replace the motor if this is the only problem identified.
2. If the system is excessively noisy, does not appear to change speeds in response to a demand (Heat, Cool, Other), or is having symptoms during the cycle such as tripping limit or freezing coil, check the following:
 - a. Wait for programmed delays to time out.
 - b. Ensure that the motors control inputs are wired to the factory supplied wiring diagram to insure motor is getting proper control signals and sequencing.
 - c. Remove the filter and check that all dampers, registers, and grilles are open and free flowing. If removing the filters corrects the problem, clean or replace with a less restrictive filter. Also check and clean the blower wheel or coil as necessary.
 - d. Check the external static pressure (total of both supply and return) to insure that you are within the ranges as listed on the unit serial plate. If higher than allowed, additional duct work is needed.

- e. If the motor does not shut off at the end of the cycle, wait for any programmed delays to time out (no more than 90 seconds). Also make sure that there is no call for "Continuous Fan" on the "G" terminal.
- f. If the above diagnostics do not solve the problem, confirm the voltage checks in the next section below, then continue with the "Model X13 Communication Diagnostics".

If the Motor is Not Running

1. Check for proper high voltage and ground at the (L/L1) (G) (N/L2) connections at the motor (see Figure 17). Correct any voltage issues before proceeding to the next step. The X13 Motor is voltage specific. Only the correct voltage should be applied to the proper motor. Input voltage within plus or minus 10% of the nominal 230 VAC is acceptable.
2. If the motor has proper high voltage and ground at the (L/L1) (G) (N/L2) connections, then continue with the "Model X13 Communication Diagnostics".

FIGURE 17

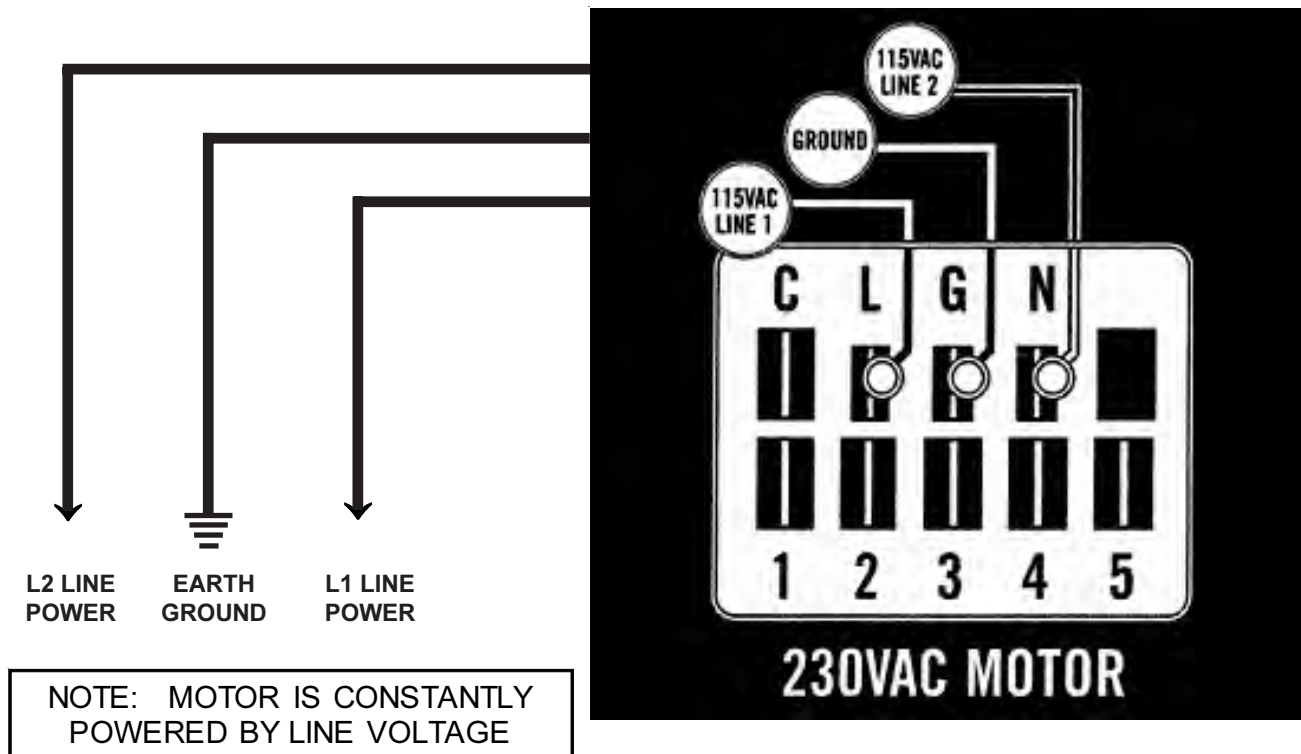

TROUBLESHOOTING GE X13-SERIES ECM MOTORS CONT'D.

Model X13 Communication Diagnostics

The X13 motor is communicated through 24 VAC low voltage (Thermostat Control Circuit Wiring).

1. Start with unit wiring diagram to confirm proper connections and voltage (see Figure 18).

2. Initiate a demand from the thermostat and check the voltage between the common and the appropriate motor terminal (1-5). ("G" input is typically on terminal #1, but refer to wiring diagram!)

- a. If the low voltage communication is not present, check the demand from the thermostat. Also check the output terminal and wire(s) from the terminal strip or control relay(s) to the motor.
- b. If the motor has proper high voltage as identified above (Motor not Running #1), and proper low voltage to a programmed terminal, and is not operating, the motor is failed, and will require replacement.

FIGURE 18

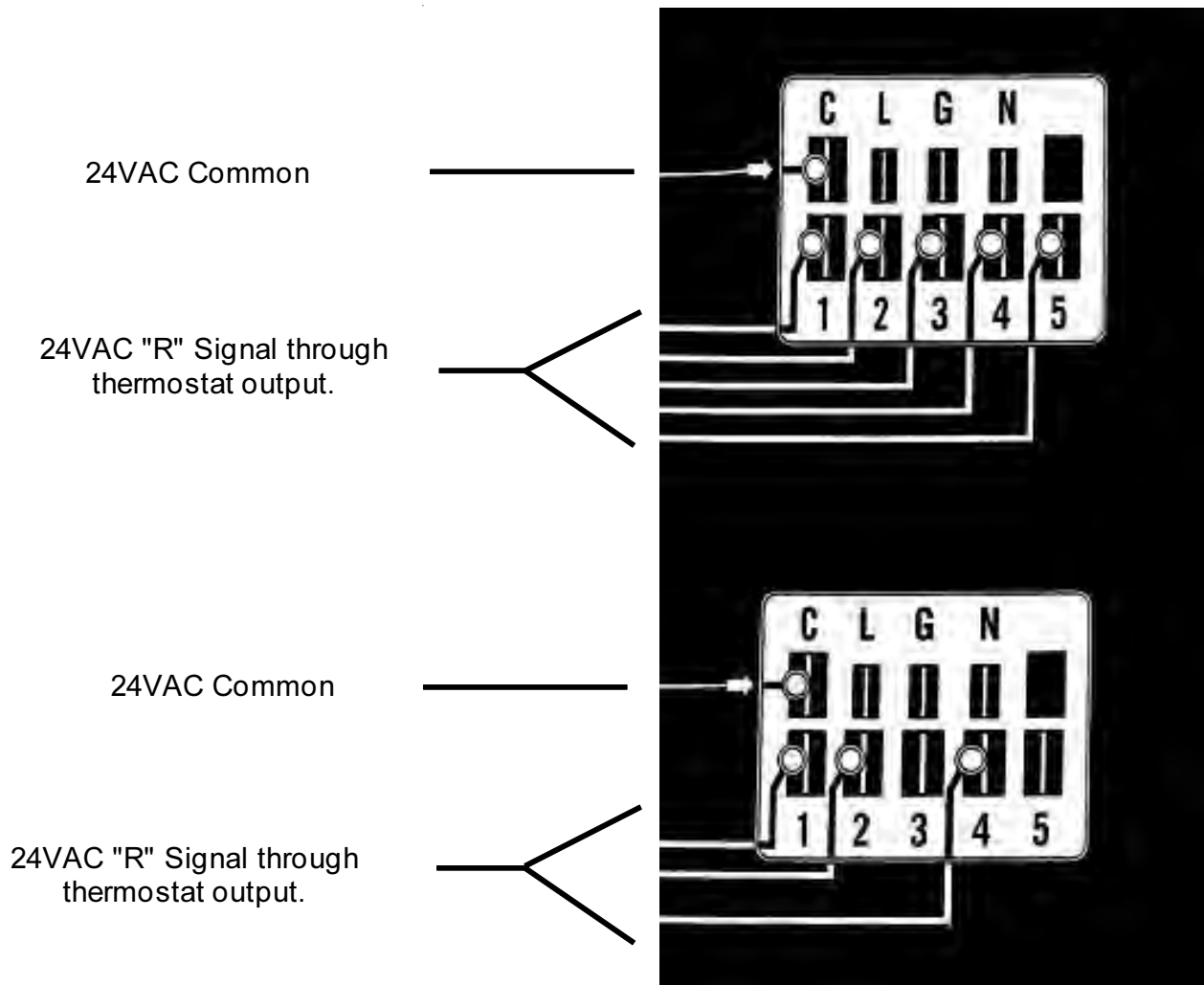

ACCESSORIES

ADD-ON GVDM-26 PUMP MODULE KIT

NOTE: This section applies only if a GVDM-26 Pump Module is added. Refer to GVDM-26 instructions for complete installation details.

GENERAL

This high efficiency water source heat pump series was designed with a refrigerant to water heat exchanger commonly known as a desuperheater coil factory-installed for ease in installing optional GVDM-26 pump module kit. The addition of this optional kit allows for heat recovery for hot water heating when connected to a home water heater. The amount of annual hot water supplied and thus additional energy cost savings will depend on the amount of hot water usage and the number of hours the heat pump operates. This pump kit is suitable for potable water.

INSTALLATION

1. Follow all local, state, and national codes applicable to the installation of the pump module kit.
2. Follow the installation instructions received with the GVDM-26 pump module kit.
3. Connect the water lines between the unit, pump module kit, and the water heater.
4. Pump power is 115V-60Hz 1-phase. A 6-foot, 3-prong cord is supplied. Pump control is accomplished by 18 gauge 3-wire connection (field-supplied) from Pump Module to the GV Heat Pump 24V terminal strip.

NOTE: The GVDM-26 Pump Module can be installed on adjacent surface or nearer to hot water storage tank if that easier facilitates the plumbing or electrical connection.

FIGURE 19
TYPICAL PUMP KIT CONNECTION TO UNIT

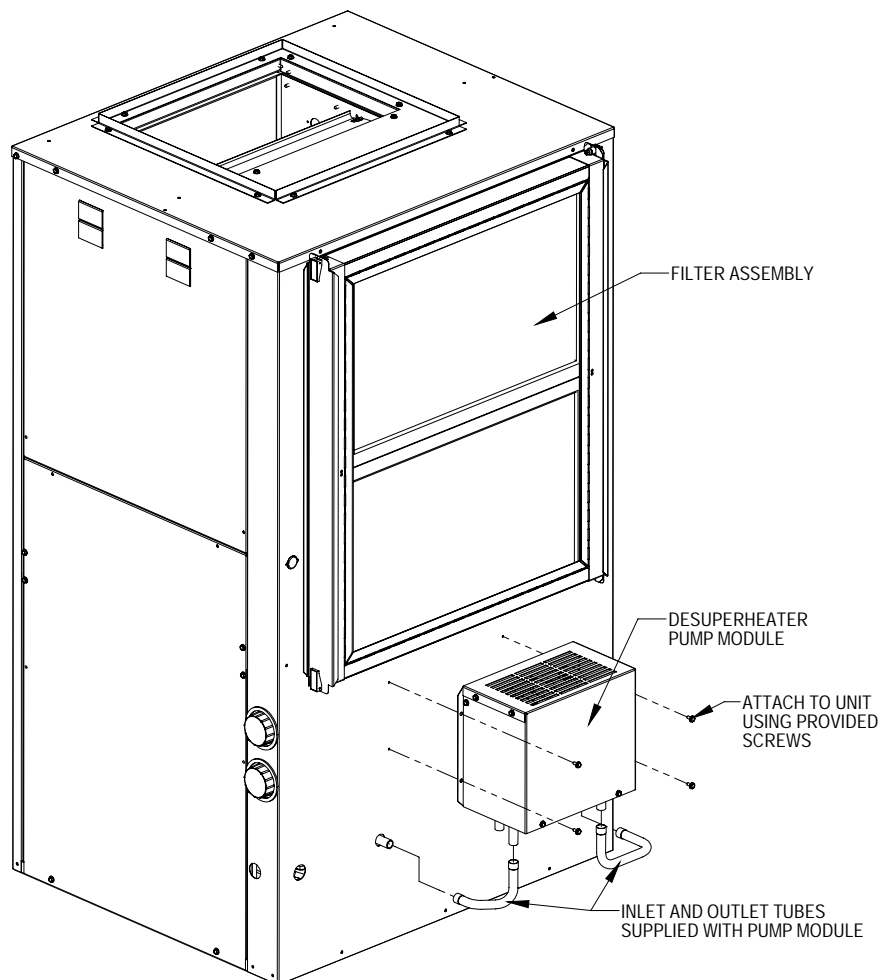

MIS-2647

GROUND SOURCE HEAT PUMP PERFORMANCE REPORT

This performance check report should be filled out by installer and retained with unit.

DATE _____ TAKEN BY: _____

1. UNIT:
Mfgr _____ Model No. _____ S/N _____

THERMOSTAT:
Mfgr _____ Model No. _____ P/N _____

2. Person Reporting _____

3. Company Reporting _____

4. Installed By _____ Date Installed _____

5. User's (Owner's) Name _____
Address _____

6. Unit Location _____

WATER SYSTEM INFORMATION

7. Open Loop System (Water Well) _____ Closed Loop System _____

A. If Open Loop where is water discharged? _____

8. The following questions are for **Closed Loop systems only**

A. Closed loop system designed by _____

B. Type of antifreeze used _____ % Solution _____

C. System type: Series _____ Parallel _____

D. Pipe material _____ Nominal Size _____

E. Pipe Installed:

1. Horizontal _____ Total length of pipe _____ ft

No. pipes in trench _____ Depth bottom pipe _____ ft

2. Vertical _____ Total length of bore hole _____ ft

THE FOLLOWING INFORMATION IS NEEDED TO CHECK PERFORMANCE OF UNIT.

FLUID SIDE DATA

		Cooling	** Heating	
9.	Entering fluid temperature	_____	_____	F
10.	Leaving fluid temperature	_____	_____	F
11.	Entering fluid pressure	_____	_____	PSIG
12.	Leaving fluid pressure	_____	_____	PSIG
13.	Pressure drop through coil	_____	_____	PSIG
14.	Gallons per minute through the water coil	_____	_____	GPM
15.	Liquid or discharge line pressure	_____	_____	PSIG
16.	Suction line pressure	_____	_____	PSIG
17.	Voltage at compressor (unit running)	_____	_____	V
18.	Amperage draw at line side of contactor	_____	_____	A
19.	Amperage at compressor common terminal	_____	_____	A
20.	* Suction line temperature 6" from compressor	_____	_____	F
21.	* Superheat at compressor	_____	_____	F
22.	* Liquid line temperature at metering device	_____	_____	F
23.	* Coil subcooling	_____	_____	F

INDOOR SIDE DATA

		Cooling	** Heating	
24.	Dry bulb temperature at air entering indoor coil	_____	_____	F
25.	Wet bulb temperature of air entering indoor coil	_____	_____	F
26.	Dry bulb temperature of air leaving indoor coil	_____	_____	F
27.	Wet bulb temperature of air leaving indoor coil	_____	_____	F
28.	* Supply air static pressure (packaged unit)	_____	_____	WC
29.	* Return air static pressure (packaged unit)	_____	_____	WC
30.	Other information about installation			

** When performing a heating test insure that 2nd stage heat is not activated

* Items that are optional

