INSTALLATION INSTRUCTIONS

SINGLE STAGE HEAT PUMPS LOW VOLTAGE CONTROL CIRCUIT WIRING

Models:

W**H	W**H*D
S**H	S**H*D
T**H	T**H*D



Climate Control Solutions

Bard Manufacturing Company, Inc.
Bryan, Ohio 43506
www.bardhvac.com

Manual : 2100-516K
Supersedes: 2100-516J
Date: 11-15-17

CONTENTS

Installation

Low Voltage Wiring	3
--------------------------	---

Figures

Figure 1 Basic HP w/Opt. Elec. Heat.....	5
Figure 2 HP w/Opt. MFAD, CRV & ERV Vent. Pkg. w/Programmable Thermostat	6
Figure 3 HP w/Opt. MFAD, CRV & ERV Vent. Pkg. w/Thermostat	7
Figure 4 HP w/Opt. MFAD, CRV & ERV Vent. Pkg. w/Thermostat with CO ₂ Controller.....	8
Figure 5 Heat Pump w/Opt. Economizer "E" Vent Option	9
Figure 6 HP w/Dehumidification Sequence & No Vent Pkg. Using T-Stat Comb.....	10
Figure 7 HP w/Dehumidification Sequence with Thermostat	11
Figure 8 HP w/Dehumidification Sequence & Opt. MFAD, CRV, & ERV Vent Pkg. Using Elec. T-Stat with Combination Temp. & Humidity Control.....	12
Figure 9 HP w/Dehumidification Sequence & Opt. MFAD, CRV & ERV Vent. Pkg. Using T-Stat (No Occupied Signal)	13
Figure 10 HP w/Dehumidification Sequence & Opt. MFAD, CRV & ERV Vent. Pkg. Using T-Stat. with CO ₂ Controller	14
Figure 11 W**H1 Dehum. with Economizer and #8403-060 Thermostat (EIFM) "E" Vent Option	15
Figure 12 1-Stage HP w/Opt. Elec. Heat without Dehum. with ECONWM* Style Economizer "W" or "T" Vent Option.....	16
Figure 13 HP w/Opt. CRVMP Vent Pkg. with Programmable T-Stat	17
Figure 14 HP w/Opt. MFAD, CRV & ERV Vent Pkg. with Thermostat	18

Tables

Table 1 Diagram to Use with Unit and Vents.....	3
Table 2 Operating Voltage Range.....	3
Table 3 Wall Thermostat.....	3
Table 4 Humidity Controls	4
Table 5 CO ₂ Controller.....	4
Table 6 Thermostat Wire Size.....	4

TABLE 1
Diagram to Use with Unit and Vents

System	Vent	None		CRV, ERV, MFAD		CRVMWH-3 CHCRV-5		EIFM Economizer		ECONWM*	
	Vent Code	X		R, M, V, P		C		E		T, W, S	
	Thermostat	Programmable		Programmable		Programmable		Programmable		Programmable	
	Model Series	No	Yes	No	Yes	No	Yes	No	Yes	No	Yes
Heat Pump	S**H T**H W**H	1	1	3, 4	2, 3, 4	14	13, 14	N/A	5	N/A	12
Heat Pump with Dehumidification	S**H*D T**H*D W**H*D	7	6, 7	9, 10	8, 9, 10	N/A	13, 14	N/A	11	N/A	N/A

Low Voltage Wiring

230/208V 1 phase and 3 phase equipment use dual primary voltage transformers. All equipment leaves the factory wired on 240V tap. For 208V operation, reconnect from 240V to 208V tap. The acceptable operating voltage range for the 240V and 208V taps are:

TABLE 2
Operating Voltage Range

TAP	RANGE
240V	253 – 216
208V	220 – 187

NOTE: *The voltage should be measured at the field power connection point in the unit and while the unit is operating at full load (maximum amperage operating condition).*

An 18 gauge copper, color-coded thermostat cable is recommended. The connection points are shown in Table 2.

Low Voltage Connection

These units use a grounded 24-volt AC low voltage circuit.

The “R” terminal is the *hot* terminal and the “C” terminal is *grounded*.

“G” terminal is the *fan input*.

“Y” terminal is the *compressor input*.

“B” terminal is the *reversing valve input*. The reversing valve must be energized for heating mode.

“R” terminal is the *24 VAC hot*.

“RT” terminal is the *24 VAC hot from transformer* on T**H and T**H*D units (used with “R” for fire/smoke shutdown).

“C” terminal is the *24 VAC grounded*.

“L” terminal is *compressor lockout output*. This terminal is activated on a high or low pressure trip by

the electronic heat pump control. This is a 24 VAC output.

“W2” terminal is *second stage heat* (if equipped).

“O1” terminal is the *ventilation input*. This terminal energizes any factory-installed ventilation option.

“E” terminal is the *emergency heat input*. This terminal energizes the emergency heat relay.

“W3” terminal is the *dehumidification input*. This terminal energizes compressor, blower and three-way valve.

Low Voltage Connections for DDC Control

Fan Only	Energize G
Cooling Mode	Energize Y, G
Heat Pump Heating	Energize Y, G, B
2nd Stage Heating w/Heat Pump (if employed)	Energize G, W2, Y, B
Ventilation	Energize G, O1
Emergency Heat	Energize B, W2, E, G
Dehumidification	Energize W3

TABLE 3
Wall Thermostat

Part Number	Predominate Features
8403-058 (TH5220D1151)	2 stage Cool, 2 stage Heat - Conventional 1 stage Cool, 2 stage Heat - Heat Pump Electronic Non-Programmable Auto or Manual changeover
8403-060 (1120-445)	3 stage Cool; 3 stage Heat HP or Conventional Auto or Manual changeover Dehumidification Output
8403-090 (T6 Pro)	2 stage Cool, 2 stage Heat - Conventional 2 stage Cool, 3 stage Heat - Heat Pump Programmable/Non-Programmable Electronic Auto or Manual changeover

**TABLE 4
Humidity Controls**

Part Number	Predominate Features
8403-038 (H600A1014)	SPDT switching, pilot duty 50VA @ 24V Humidity range 20-80% RH
8403-047 (H200-10-21-10)	Electronic dehumidistat SPST closes-on-rise Humidity range 10-90% with adjustable stops

**TABLE 5
CO₂ Controller**

Part Number	Predominate Features
8403-067	Normally Open SPST relay closes-on-rise 24V dual wave length sensor. Default setting 950ppm, adjustable to 0-2000ppm Default off setting 1000ppm, adjustable to 0-200 ppm can be calibrated

**TABLE 6
Thermostat Wire Size**

Transformer VA	FLA	Wire Gauge	Maximum Distance in Feet
55	2.3	20 gauge	45
		18 gauge	60
		16 gauge	100
		14 gauge	160
		12 gauge	250

FIGURE 1
Low Voltage Wiring Diagram:
Heat Pump with Optional Electric Heat
No Economizer or Ventilation Packages

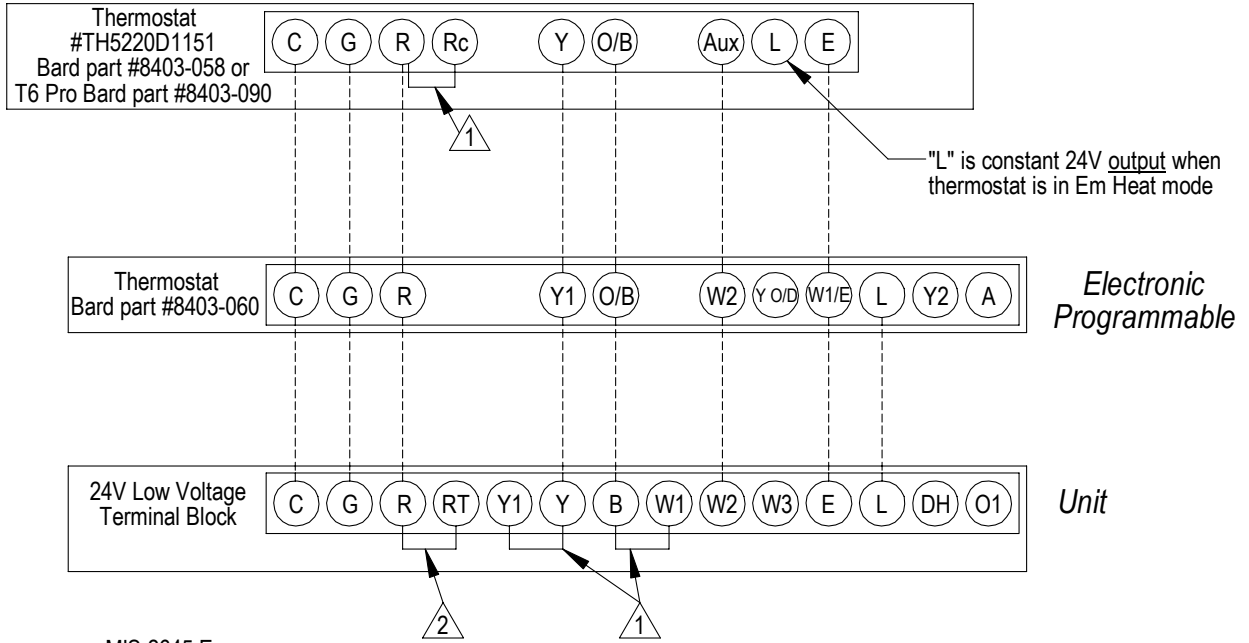

- △1 Factory Jumper Installed
- △2 Factory installed jumper (on applicable models). Remove jumper and connect to N.C fire alarm circuit if emergency shutdown required.

FIGURE 2
Low Voltage Wiring Diagram:
Heat Pump with Optional MFAD, CRV & ERV Ventilation Packaging
with Programmable Thermostat (Recommended)

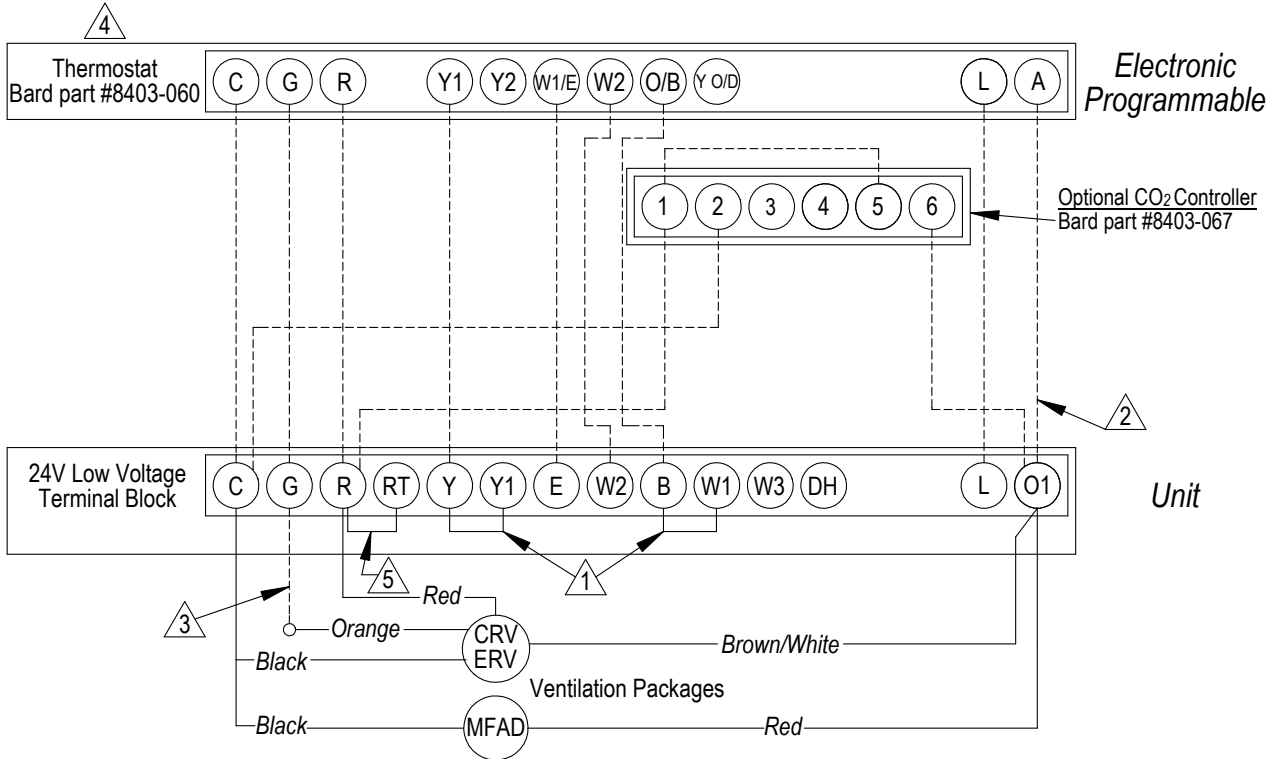

- 1 Factory Jumper Installed
- 2 Do not connect "A" from tstat #8403-060 if optional CO₂ controller is used.
- 3 Connect orange wire to "G" only if optional CO₂ controller is used.
- 4 Must be configured to programmable and fan set to programmed for the "A" output to function during scheduled occupied periods
- 5 Factory installed jumper (on applicable models). Remove jumper and connect to N.C fire alarm circuit if emergency shutdown required.

MIS-2633 D

FIGURE 4
Low Voltage Wiring Diagram:
Heat Pump with Optional MFAD, CRV and ERV Ventilation Packaging
with Thermostat with CO₂ Controller

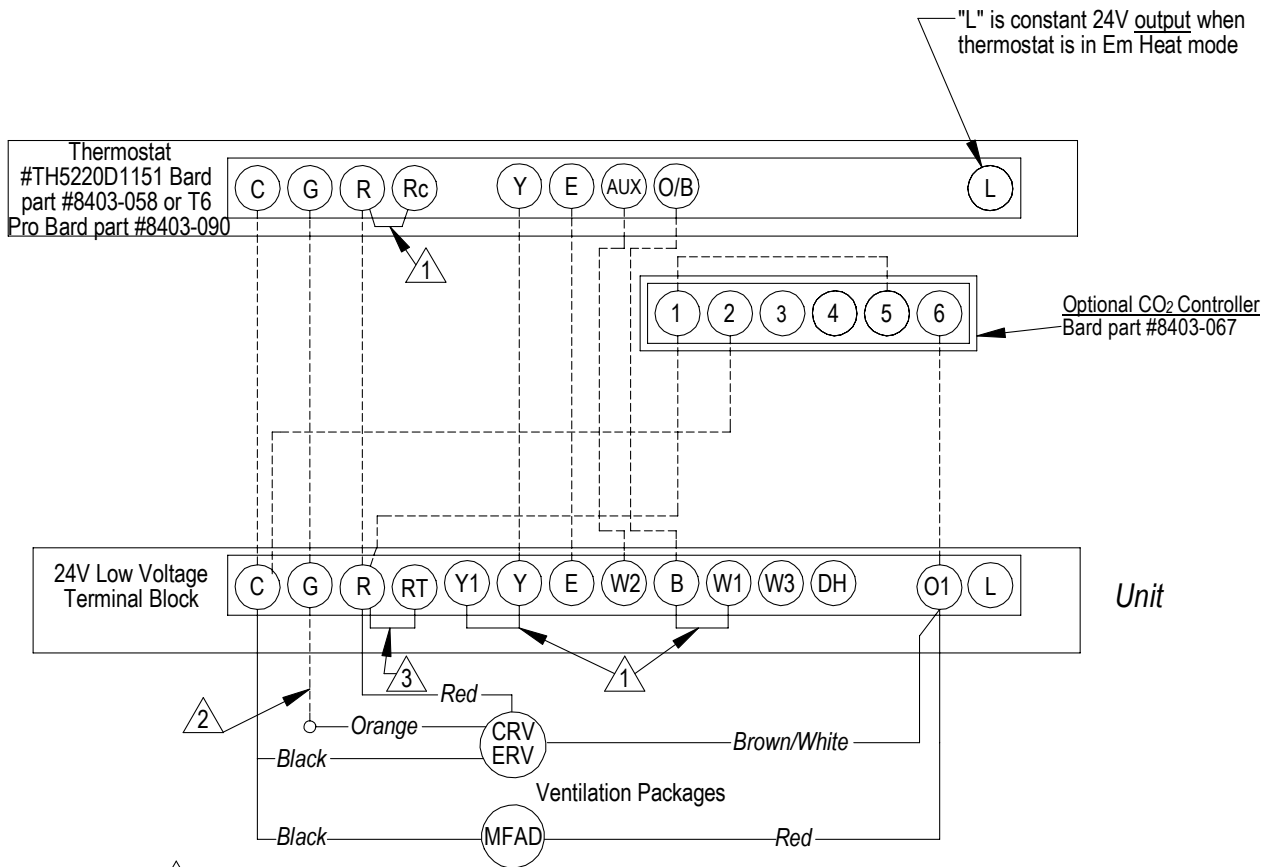

- ⚠️ 1 Factory Jumper Installed
- ⚠️ 2 Connect orange wire to "G" only if optional CO₂ controller is used.
- ⚠️ 3 Factory installed jumper (on applicable models). Remove jumper and connect to N.C fire alarm circuit if emergency shutdown required.

MIS-2634 G

FIGURE 5
Low Voltage Wiring Diagram:
Heat Pump with Optional EIFM Economizer
“E” Vent Option

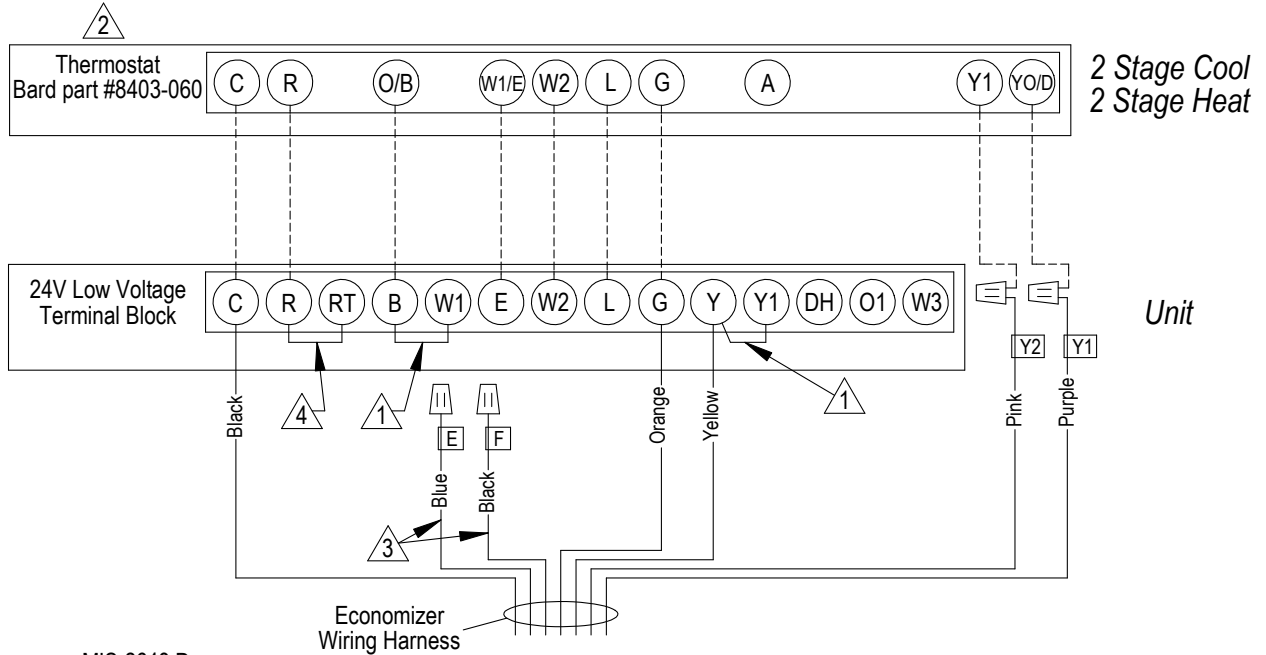

MIS-2648 D

- ① Factory Jumper Installed.
- ② Must be configured for economizer with YO/D output to be active as first stage cooling.
- ③ These wires are used in special control applications only.
- ④ Factory installed jumper (on applicable models). Remove jumper and connect to N.C fire alarm circuit if emergency shutdown required.

FIGURE 6
Low Voltage Wiring Diagram:
Heat Pump with Dehumidification Sequence and No Ventilation Package
Using Thermostat #8403-060 Combination Temperature and Humidity Controller

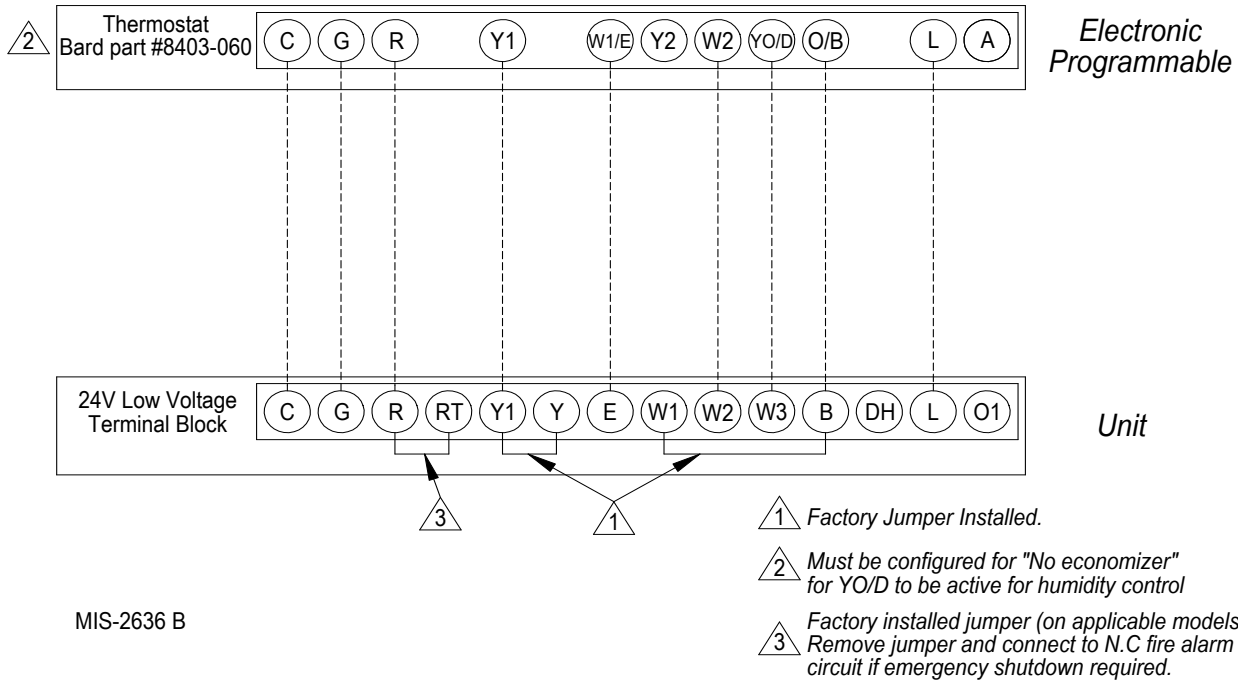

MIS-2636 B

FIGURE 7
Low Voltage Wiring Diagram:
Heat Pump with Dehumidification Sequence

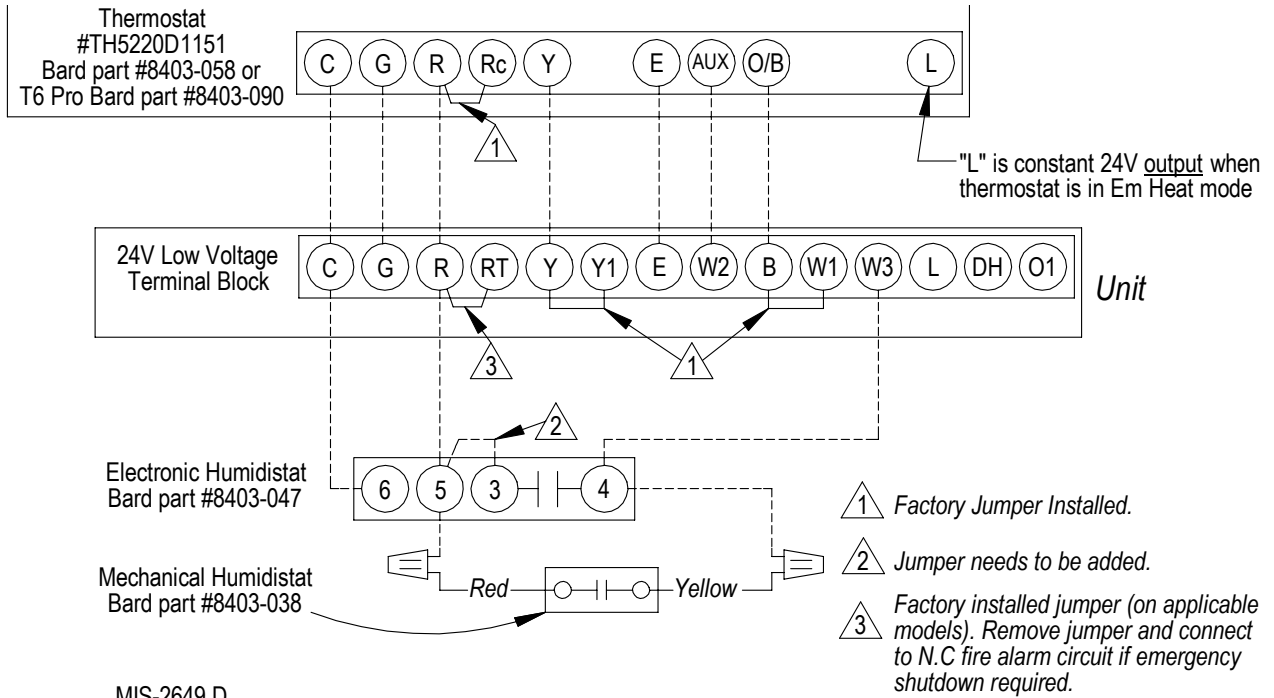
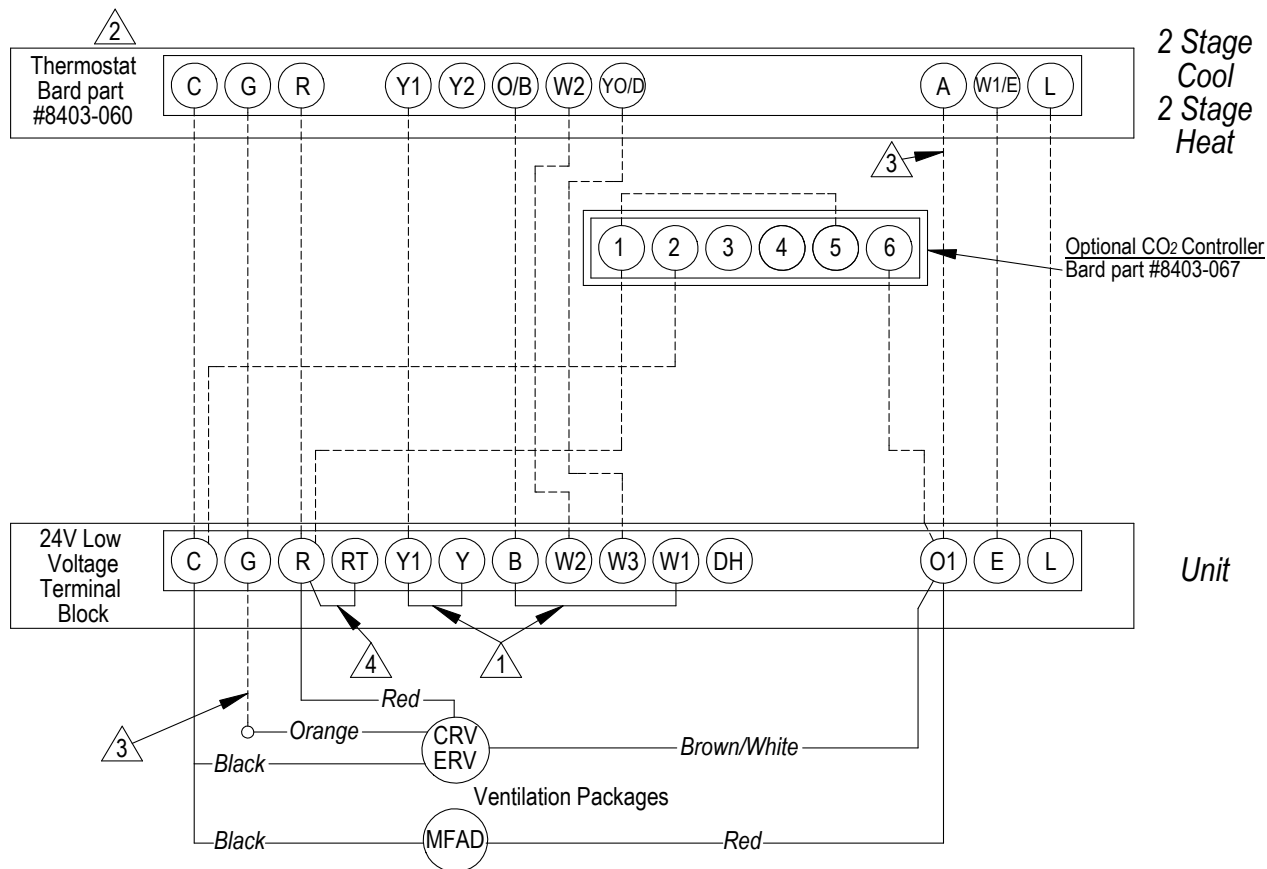

FIGURE 8
Low Voltage Wiring Diagram:
Heat Pump with Dehumidification Sequence and Optional MFAD, CRV & ERV Ventilation Packaging
Using Electronic Thermostat with Combination Temperature and Humidity Control with Optional CO₂ Controller



- 1 Factory Jumper Installed
- 2 Must be configured to "no economizer" to make YO/D output active for humidity control. Must be configured to programmable and fan set to programmed fan for the "A" output to function during scheduled occupied periods.
- 3 Do not connect "A" from thermostat if optional CO₂ controller is used. Connect orange wire to "G" only when optional CO₂ controller is used.
- 4 Factory installed jumper (on applicable models). Remove jumper and connect to N.C fire alarm circuit if emergency shutdown required.

MIS-2637 D

FIGURE 9
Low Voltage Wiring Diagram:
Heat Pump with Dehumidification Sequence and Optional MFAD, CRV & ERV Ventilation Packaging
Using Thermostat (No Occupied Signal)

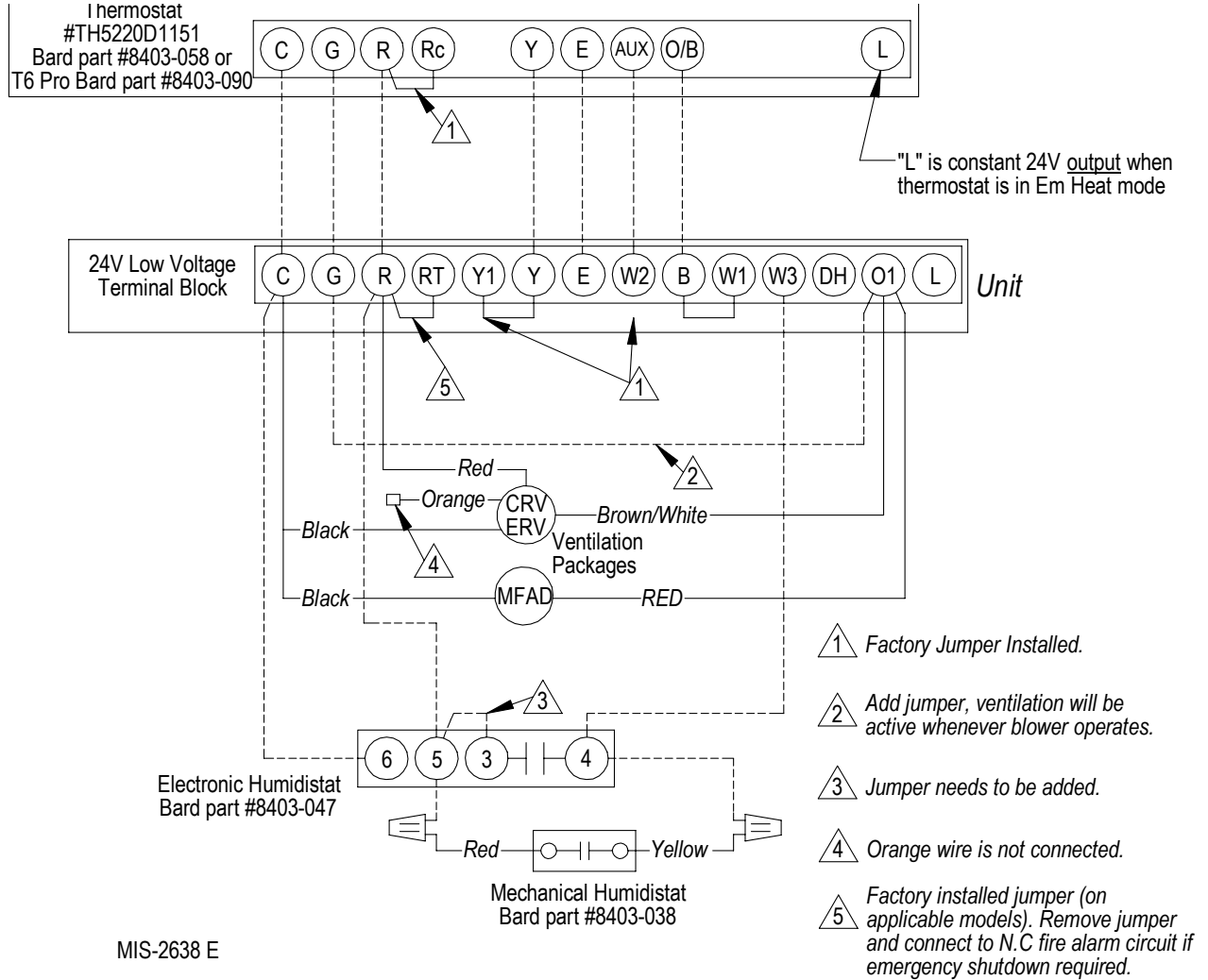

MIS-2638 E

FIGURE 10
Low Voltage Wiring Diagram:
Heat Pump with Dehumidification Sequence and Optional MFAD, CRV & ERV Ventilation Packaging
Using Thermostat with CO₂ Controller

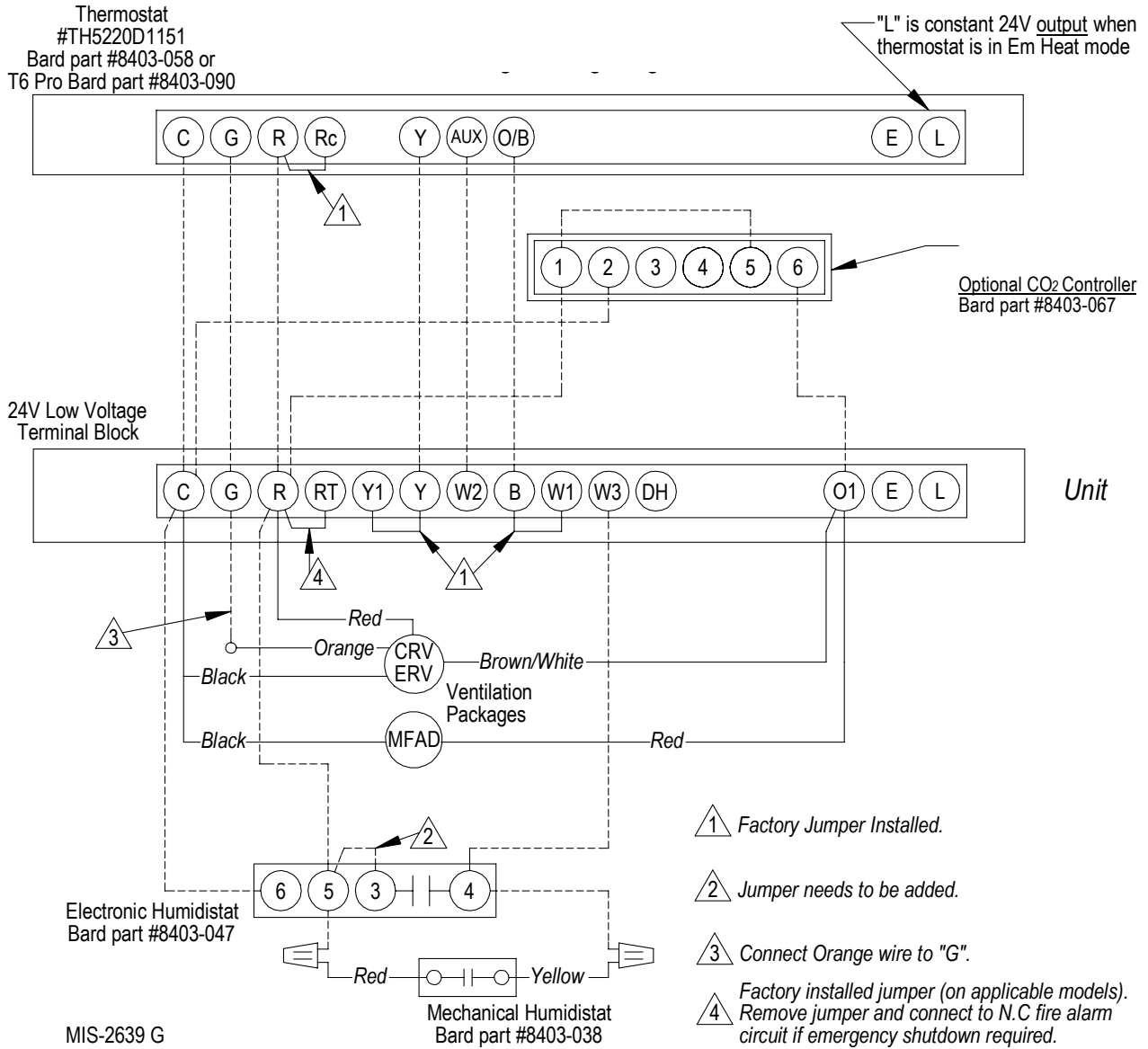
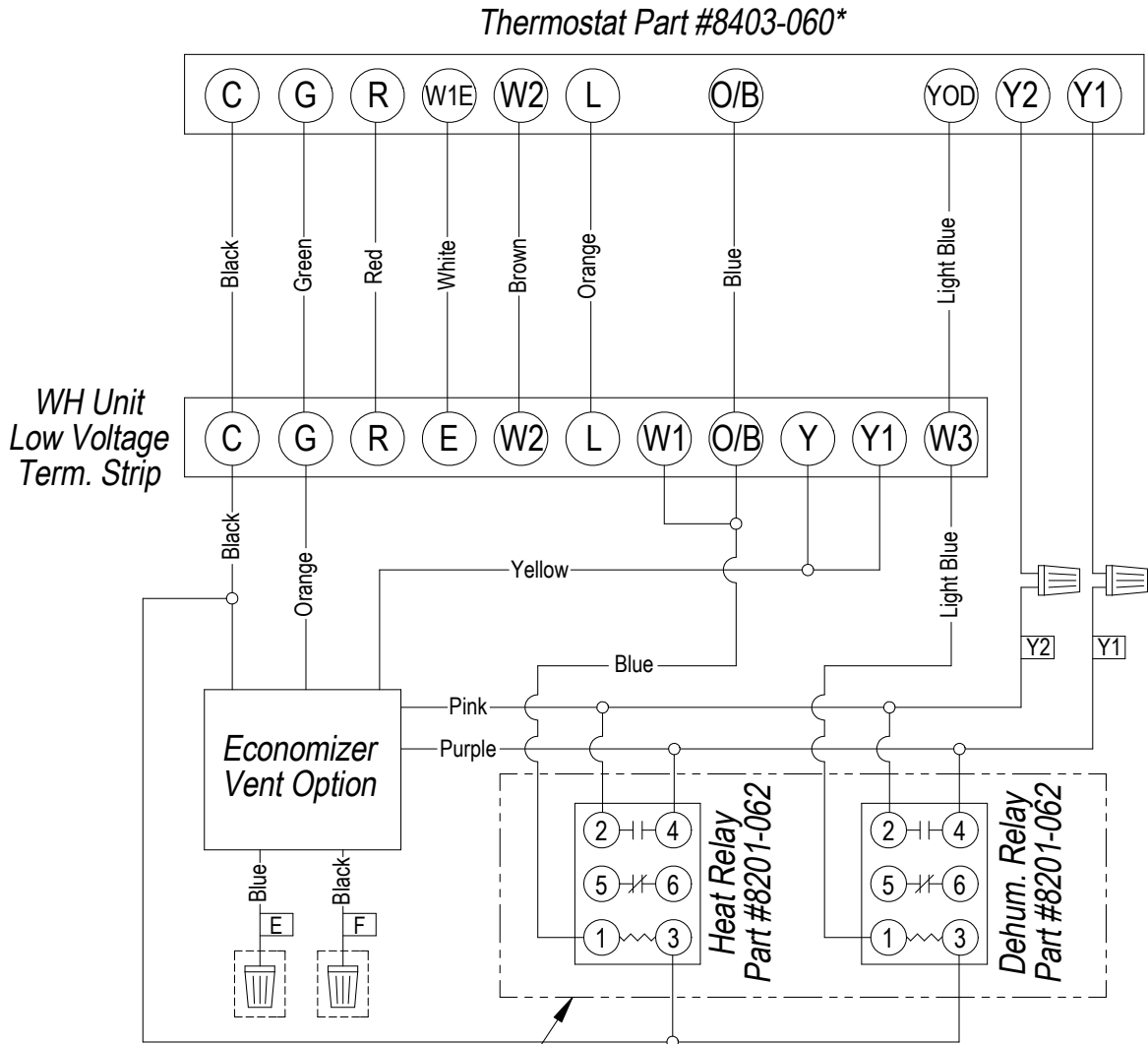

FIGURE 11
Low Voltage Wiring Diagram:
WH1 Dehum. with Economizer**
and #8403-060 Thermostat (EIFM)
"E" Vent Option



⚠ DANGER
 *ELECTRICAL SHOCK HAZARD
 *DISCONNECT POWER BEFORE
 SERVICING.

RELAYS AND
 ASSOCIATED WIRING
 ARE FIELD INSTALLED

***Thermostat Model Configuration Notes:**

- 1.) Configured for "Heat Pump"
- 2.) Configured for "Multi-Stage"
- 3.) Configured for "No Economizer"
- 4.) Configured CS2000A Attached = NO

4200-001 B

FIGURE 12
Low Voltage Wiring Diagram:
1-stage Heat Pump with Optional Electric Heat
without Dehumidification
with ECONWM* Style Economizer
“S”, “W” or “T” Vent Option

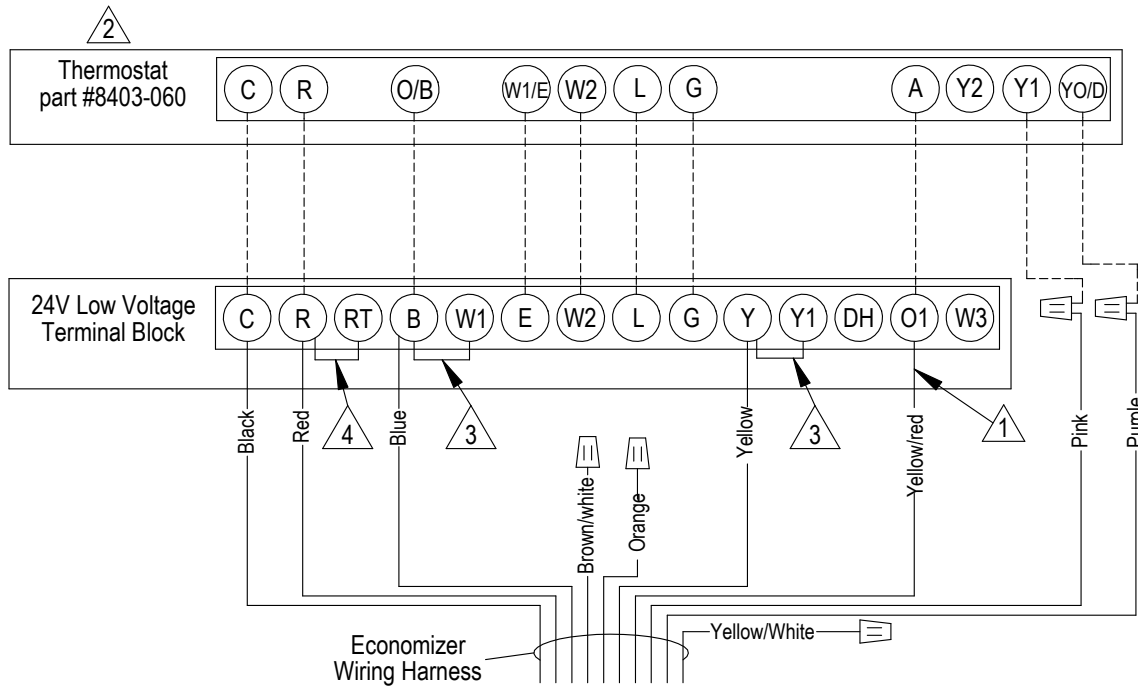

- ⚠️ 1 Must be energized to enable minimum position. NOTE: Economizer Control Default Setting is 10V (100%). Depending upon application may require setting to lower value.
- ⚠️ 2 Must be configured for heat pump / multistage/ no economizer/ to enable YO/D output to be active as dehumidification output
- ⚠️ 3 Factory Jumper Installed.
- ⚠️ 4 Factory installed jumper (on applicable models). Remove jumper and connect to N.C fire alarm circuit if emergency shutdown required.

MIS-2981 D

FIGURE 13
Low Voltage Wiring Diagram:
Heat Pump with Optional CRVMWH-3 or CHCRV-5 Ventilation Packaging
with Programmable Thermostat (Recommended)

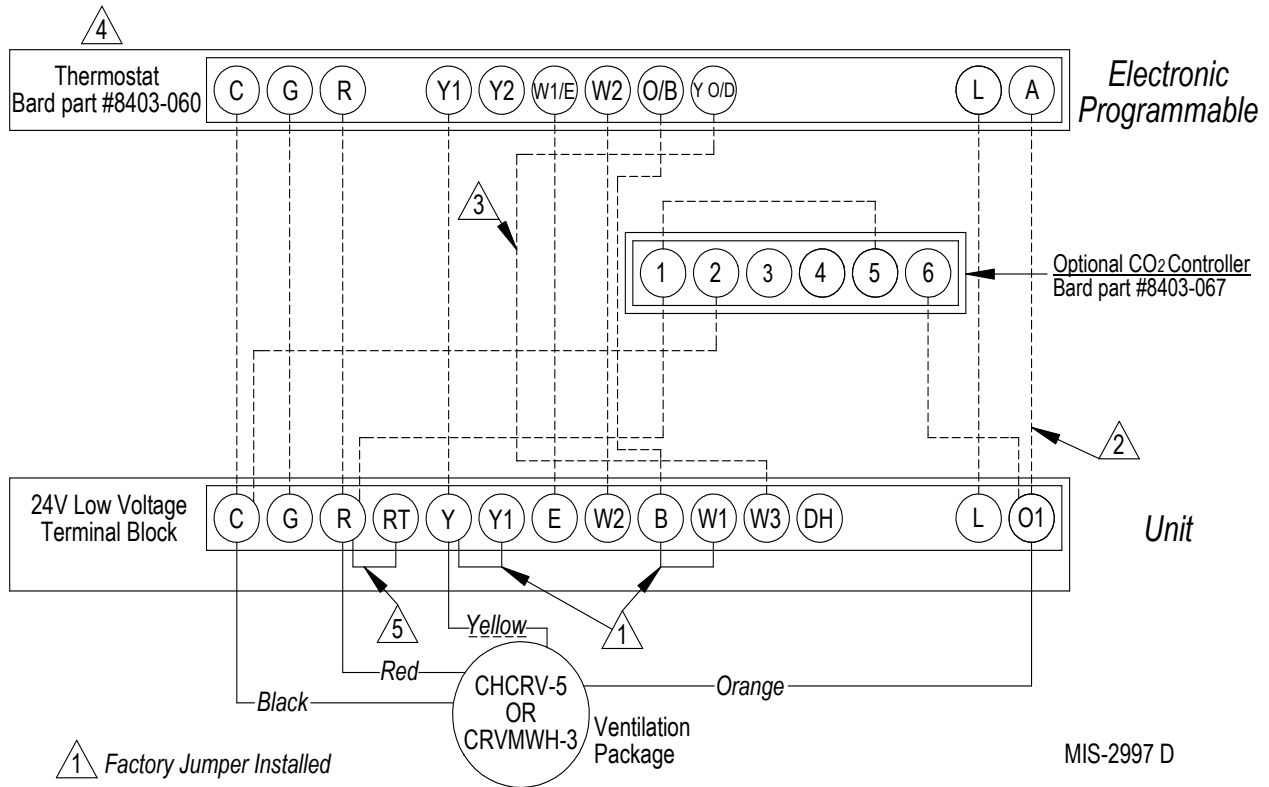

MIS-2997 D



- 1 Factory Jumper Installed
- 2 Do not connect "A" from tstat #8403-060 if optional CO₂ controller is used.
- 3 Wire only needed for dehumidification units
- 4 Must be configured to programmable and fan set to programmed for the "A" output to function during scheduled occupied periods
- 5 Factory installed jumper (on applicable models). Remove jumper and connect to N.C fire alarm circuit if emergency shutdown required.

FIGURE 14
Low Voltage Wiring Diagram:
Heat Pump with Optional CRVMWH-3 or CHCRV-5 Ventilation Packaging
with Thermostat (No Occupied Signal)

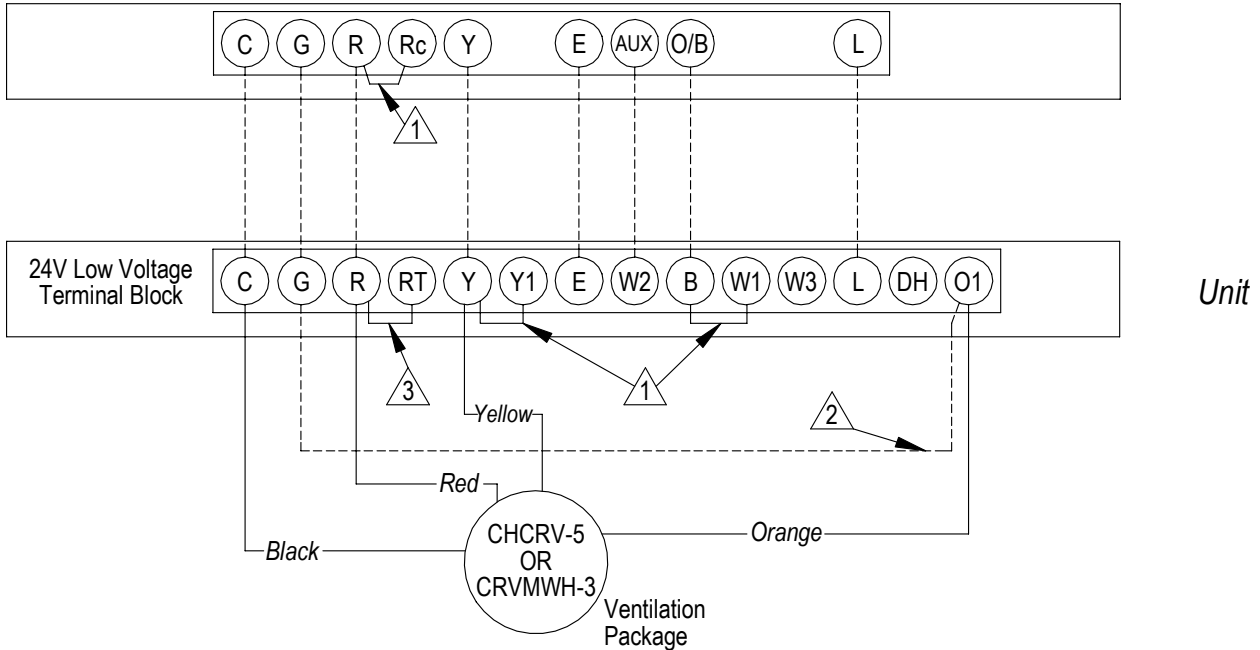
Thermostat
 #TH5220D1151
 Bard part #8403-058 or
 T6 Pro Bard part #8403-090



MIS-2998 C

-  *Factory Jumper Installed*
-  *Add jumper, ventilation will be active whenever blower operates.*
-  *Factory installed jumper (on applicable models). Remove jumper and connect to N.C fire alarm circuit if emergency shutdown required.*