INSTALLATION INSTRUCTIONS

DOUBLE O-RING GEOTHERMAL FLOW CENTERS

Models: DORFC-1 DORFC-2



DORFC-1



DORFC-2

BMC, Inc.
Bryan, Ohio 43506

Manual: 2100-518A
Supersedes: 2100-518
File: Volume I, Tab 8
Date: 07-08-11

CONTENTS

Getting Other Informations and Publications	3	Flow Center Wiring	
General Information		Description	16
Flow Center Nomenclature	4	Flushing & Charging	
Application		General	18
Description	4	Procedures for Adding Antifreeze	18
Safety	4	Flushing & Filling Earth Loop & Units	22
Danger	4	Flushing Earth Loop Only	22
Warning	4	Flushing Unit Only	23
Caution	4	Flow Center Initial Startup	
Notice	4	General	24
Flow Center Mounting Instructions		Procedures for Pressurizing the System	24
Notice	7	Pressure/Temperature Plugs	24
Stud Wall	7	Troubleshooting	
Concrete/Masonry Wall	7	Troubleshooting Table	27
Side of Unit	7	Antifreeze Selection & Use	
Piping Installation		General	28
Description	10	Methanol	28
Actual Photo Images	10-11	Ethanol	28
Multiple Unit to Single Loop Connection		Propylene Glycol	29
Description	12	Potassium Acetate (GS4)	29
		Antifreeze Verification	30

Figures

Figure 1A Performance Model DORFC-1	5
Figure 1B Performance Model DORFC-2	5
Figure 2 Flow Center Dimensions	6
Figure 3 Pump Horizontal Applications	8
Figure 4A Mounting - Studded Wall	9
Figure 4B Mounting - Masonry Wall	9
Figure 5A Flow Center Connection to GV Series ..	12
Figure 5B Flow Center Connection to GT Series ..	13
Figure 5C Flow Center Connection to QW Series ..	14
Figure 6 Multiple Unit Connection to Singular	15
Figure 7 Electrical Connections	17
Figure 8 Connecting Flush Cart to Flow Center ..	19
Figure 9A Positioning - Flush Loop	20
Figure 9B Positioning - Flush Loop & Unit	20
Figure 9C Positioning - Flush Unit	21
Figure 9D Positioning - Operation	21
Figure 10 Pressure Temperature Ports	25
Figure 11 Density Verification - Solution Strength ...	30

Tables

Table 1 Fusion or Barbed Fittings	10
Table 2 Electrical Ratings	16
Table 3A GV Series Coil Pressure Drop	25
Table 3B GT Series Coil Pressure Drop	26
Table 3C QW Series Coil Pressure Drop	26
Table Troubleshooting	27
Table 4 Fluid Volume	29
Table 5 Percentages by Volume	29
Table 6 Propylene Glycol Specific Gravity	30
Table 7 Methanol Specific Gravity	30

GETTING OTHER INFORMATION AND PUBLICATIONS

These publications can help you install the air conditioner or heat pump. You can usually find these at your local library or purchase them directly from the publisher. Be sure to consult current edition of each standard.

National Electrical Code ANSI/NFPA 70

Standard for the Installation ANSI/NFPA 90A
of Air Conditioning and Ventilating Systems

Standard for Warm Air ANSI/NFPA 90B
Heating and Air Conditioning Systems

Load Calculation for Residential ACCA Manual J
Winter and Summer Air Conditioning

Duct Design for Residential ACCA Manual D
Winter and Summer Air Conditioning and Equipment
Selection

Closed-Loop/Ground Source Heat Pump IGSHPA
Systems Installation Guide

Grouting Procedures for Ground-Source IGSHPA
Heat Pump Systems

Soil and Rock Classification for IGSHPA
the Design of Ground-Coupled Heat Pump Systems

Ground Source Installation Standards IGSHPA

Closed-Loop Geothermal Systems IGSHPA
– Slinky Installation Guide

FOR MORE INFORMATION, CONTACT THESE PUBLISHERS:

ACCA **Air Conditioning Contractors of America**
1712 New Hampshire Avenue
Washington, DC 20009
Telephone: (202) 483-9370
Fax: (202) 234-4721

ANSI **American National Standards Institute**
11 West Street, 13th Floor
New York, NY 10036
Telephone: (212) 642-4900
Fax: (212) 302-1286

ASHRAE **American Society of Heating Refrigerating,
and Air Conditioning Engineers, Inc.**
1791 Tullie Circle, N.E.
Atlanta, GA 30329-2305
Telephone: (404) 636-8400
Fax: (404) 321-5478

NFPA **National Fire Protection Association**
Batterymarch Park
P.O. Box 9101
Quincy, MA 02269-9901
Telephone: (800) 344-3555
Fax: (617) 984-7057

IGSHPA **International Ground Source
Heat Pump Association**
490 Cordell South
Stillwater, OK 74078-8018

GEOTHERMAL FLOW CENTERS NOMENCLATURE

DORFC
—
Double
O-Ring
Flow
Center

2

1 = 1-Pump Version, 208/230V, 60 Hz, 1-phase, 22' HD @ 16 GPM

2 = 2-Pump Version, 208/230V, 60 Hz, 1-phase, 44' HD @ 16 GPM

FLOW CENTER DESCRIPTION

The DORFC Series Flow Centers are a compact, easy to mount polystyrene cabinet that contains 3-way valves and pump(s) with connections for flushing, filling and pumping fluids for geothermal closed loop systems. The proven design is foam insulated to prevent condensation and full flow service valves minimize pressure drop.

One or two Grundfos pump models UP26-99 are available based upon flow requirements and loop design.

Unit and loop connections are designed for double o-ring fittings with several varieties of connections available (fusion, threaded, barbed and sweat). Pump motor(s) are 230VAC, 60 Hz, 1-phase.

An attractive light gray polystyrene cabinet (that matches geothermal unit) with black pump(s) provides an aesthetically pleasing enclosure for pump(s) and valves.

SAFETY

Warnings, cautions and notices appear throughout this Manual. Read these items carefully before attempting any installation, service or troubleshooting of the equipment.

DANGER

Indicates an immediate hazardous situation which, if not avoided, will result in death or serious injury. DANGER labels on unit access panels must be observed.

WARNING

Indicates a potentially hazardous situation which, if not avoided, will result in death or serious injury.

CAUTION

Indicates a potentially hazardous situation or an unsafe practice which, if not avoided, could result in minor or moderate injury or product or property damage.

NOTICE

Notification of installation, operation or maintenance information, which is important, but which is not hazard-related.



WARNING

Failure to do so could cause property damage, bodily harm or death.



CAUTION

Failure to do so could cause property damage, bodily harm or death.

FLOW CENTER PERFORMANCE

FIGURE 1A
PERFORMANCE MODEL DORFC-1 FLOW CENTER

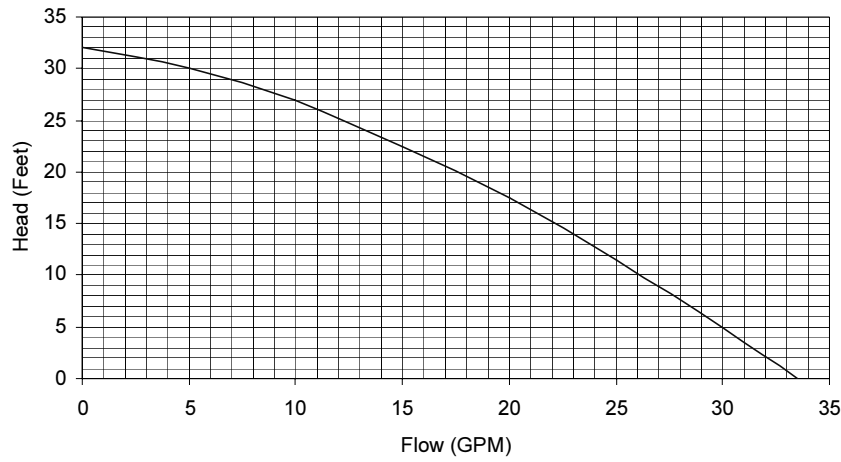
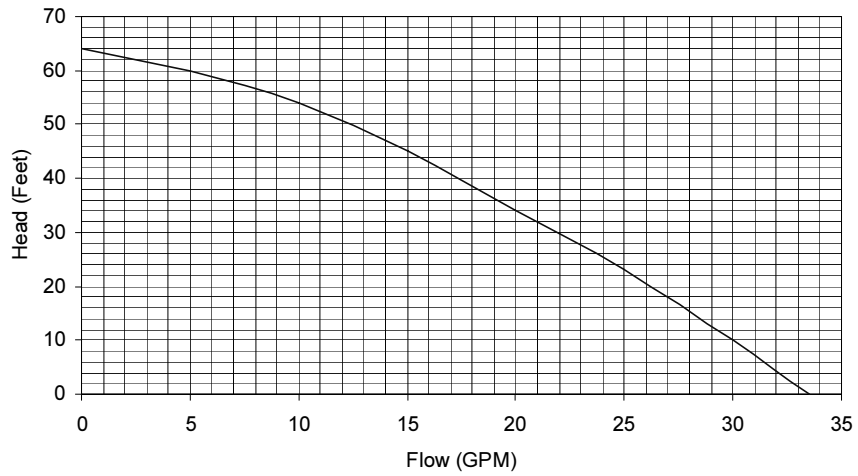
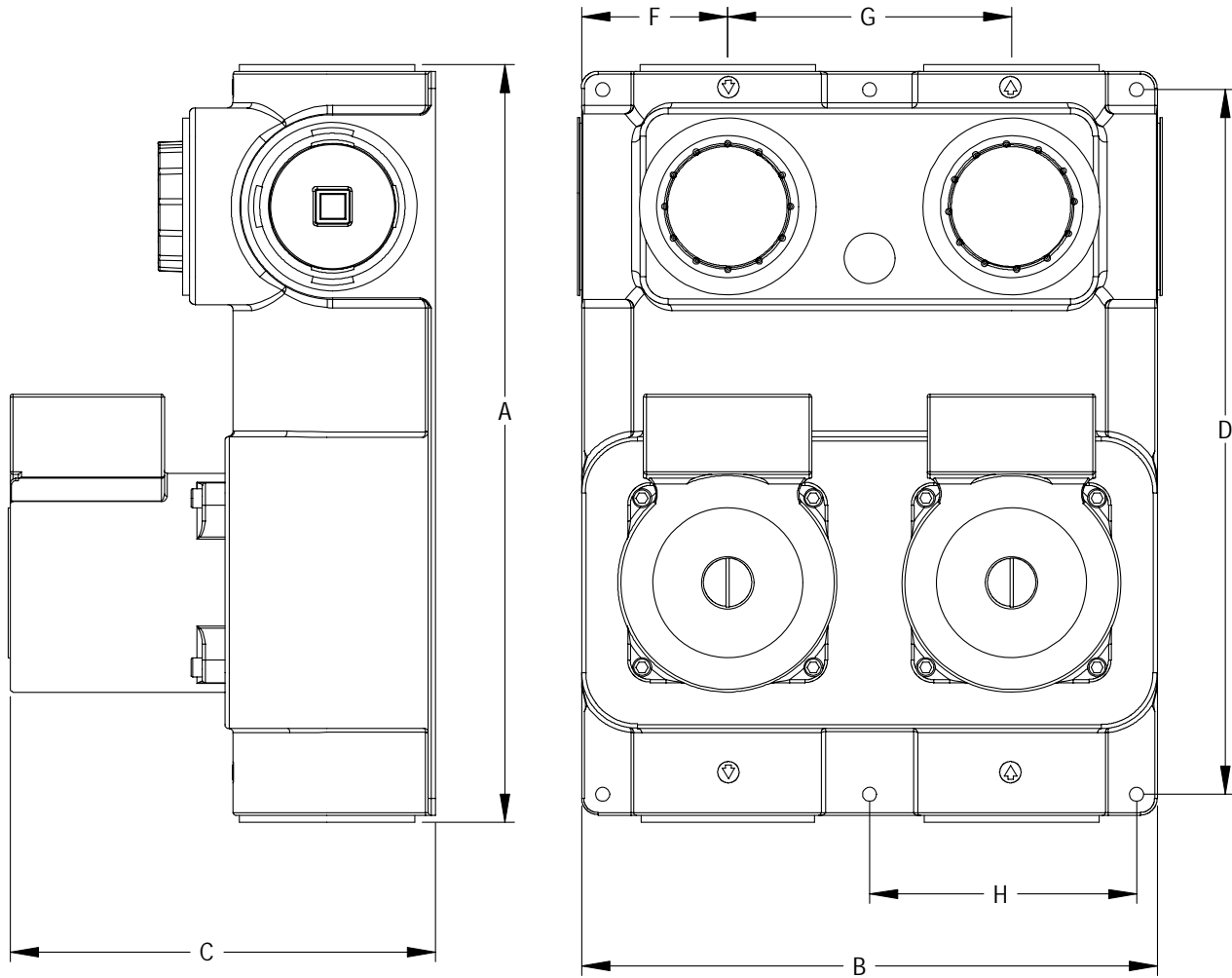

FIGURE 1B
PERFORMANCE MODEL DORFC-2 FLOW CENTER



DIMENSIONAL DRAWING

**FIGURE 2
FLOW CENTER DIMENSIONS**



	A	B	C	D	E	F	G	H
INCHES	13.5	10.3	7.5	12.4	2.0	2.6	5.0	4.7
CM	34.3	26.2	19.1	31.5	5.1	6.7	12.7	11.4

TYPE	SHIPPING WEIGHT
DORFC-1	26 LBS
DORFC-2	31 LBS

MIS-2658



CAUTION

The following instructions represent industry accepted installation practices for closed-loop earth coupled (ground loop) installations. Instructions are provided to assist the contractor in installing trouble free ground loops. These instructions are recommendations only. State/provincial and local codes **MUST** be followed and installation **MUST** conform to **ALL** applicable codes. It is the responsibility of the installing contractor to determine and comply with **ALL** applicable codes and regulations.

NOTICE

The Flow Center must be mounted with the pump shaft in the horizontal position. In other words, it should always be mounted in a vertical position (not on its back or mounted to the ceiling). See Figure 3.

The pump should be located as close to the unit as possible to limit the length of rubber hose kit or interconnect piping and thus its associated pressure drop.

STUD WALL

Mounting on stud wall with or without drywall can be accomplished by using two (2) lag bolts through the top and bottom center holes directly into the stud. See Figure 4A.

CONCRETE/MASONRY WALL

Mounting onto a concrete wall can be accomplished typically using four (4) 1/4" diameter tapcon cement screws in the four (4) outer corner mounting holes. See Figure 4B.

SIDE OF UNIT

Mounting on the side of the unit is possible, but not necessarily recommended because it can inhibit serviceability and also lead to vibration of the sheet metal casing. It could also lead to puncturing an internal refrigerant or water pipe. If necessary, however, the flow center can be mounted to the sheet metal casing utilizing four (4) self-drilling screws. (*Pay close attention not to puncture internal components.*)

**FIGURE 3
PUMP HORIZONTAL APPLICATIONS**

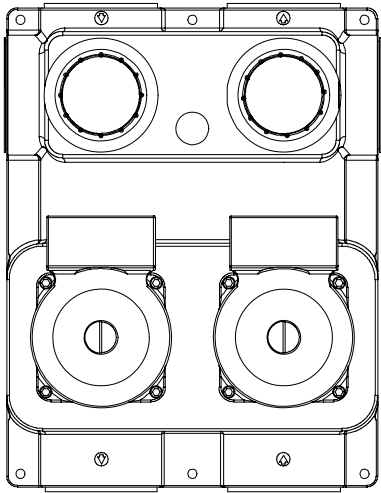

OK
IMPELLER SHAFT
HORIZONTAL

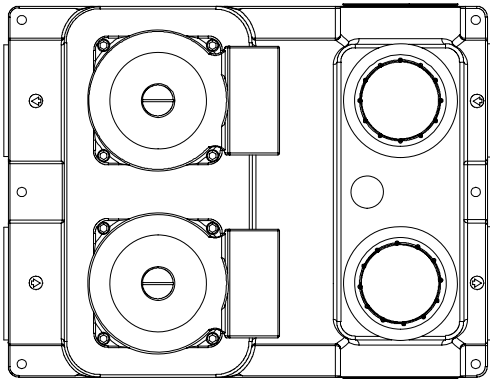
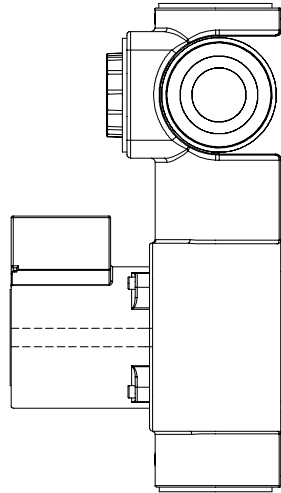

OK
IMPELLER SHAFT
HORIZONTAL

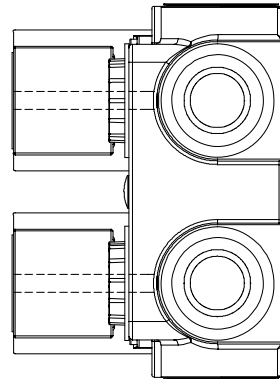

NO
IMPELLER SHAFT
CAN NOT BE
VERTICAL

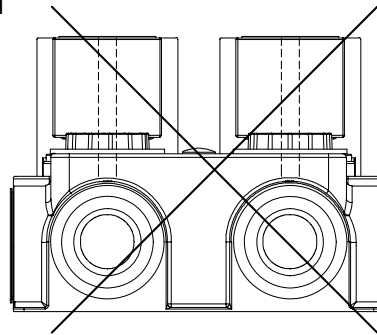
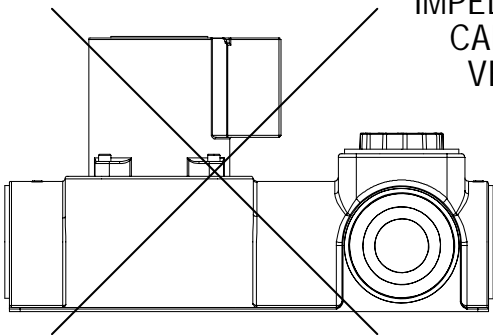

MIS-2659

**FIGURE 4
MOUNTING**

**FIGURE 4A
Studded Wall Mounting**

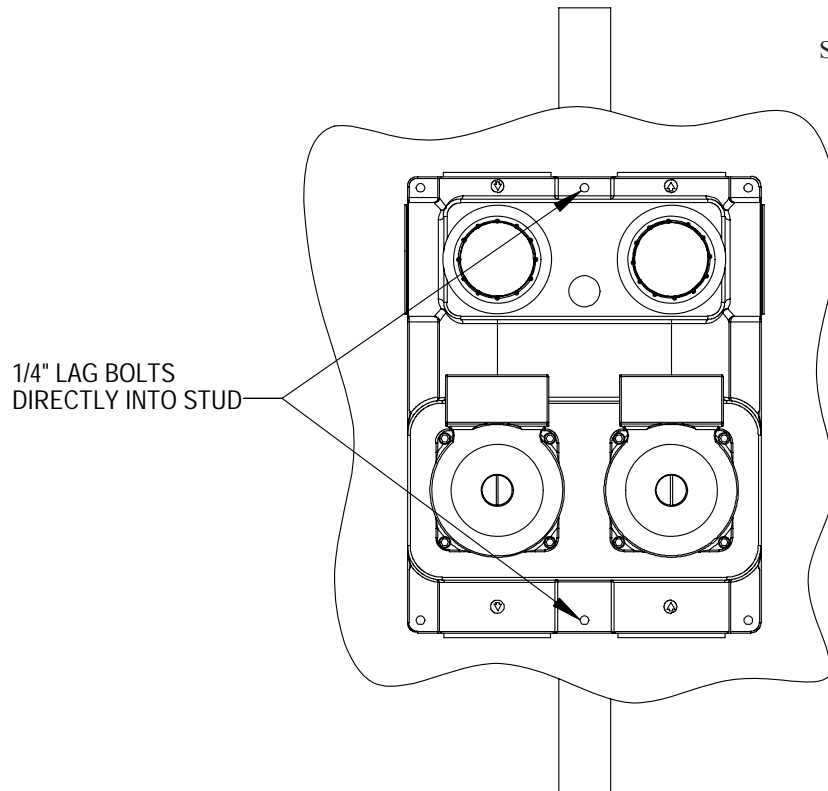

**FIGURE 4B
Masonry Wall Mounting**

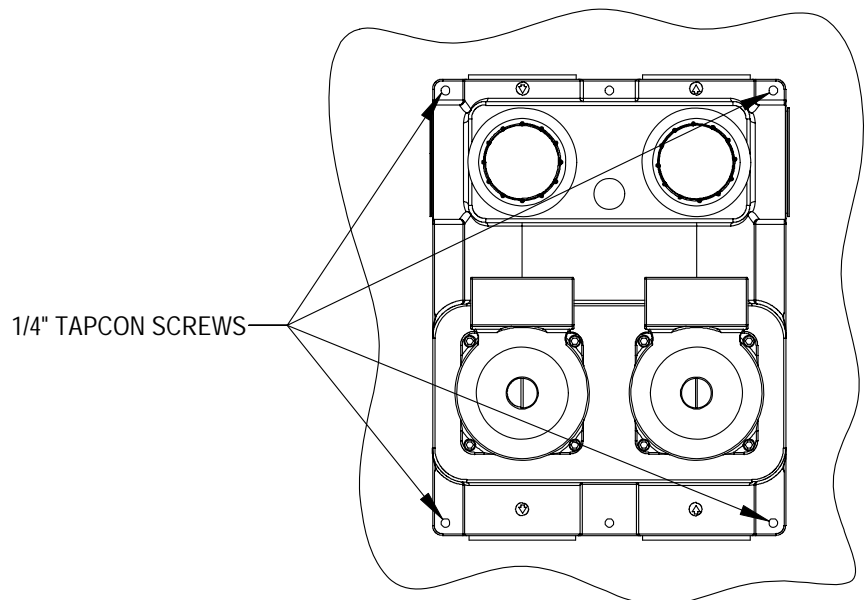

MIS-2660

PIPING INSTALLATION

The Flow Center features Double O-Ring fittings for installation flexibility and ease of installation – maintaining a reliable connection. Table 1 illustrates the connection options available for Flow Centers. Pressure drop in piping systems should be calculated to ensure adequate flow through the unit. All piping should be properly insulated with closed cell insulation of 1/2" wall thickness. Piping insulation should be glued and sealed to prevent condensation using closed cell insulation glue. ***The swivel connectors on the flow center and at the unit are designed to be hand-tightened only.***

NOTE: *Apply petroleum jelly to O-Rings to prevent damage and aid in insertion.*

Loop side piping is typically polyethylene piping directly into the flow center. Connection to the flow center can be made with either a fusion or barbed fitting as shown in Table 1.

Connection between the flow center and the geothermal heat pump typically would be made using the hose kit (DORLFCK-1), which contains all fittings necessary for connection between the heat pump and the flow center as shown in Figure 5. Other variety of materials may also be used for this connection - such as PE or copper piping.

TABLE 1

Description	Part Number
1-1/4" PE Fusion X Double O-Ring	DORF125-S
Double O-Ring Loop Flow Center Kit	DORLFCK-1
1" Barb X Double O-Ring (includes {4} hose clamps)	DORB1-S-4HC
1" MPT X Double O-Ring	DORMP1-S
1" FPT X Double O-Ring	DORFP1-S
1" Copper Sweat X Double O-Ring (includes {2} P/T fittings)	DORS1-S
1" Hose Barb X Double O-Ring 90° Elbow (includes {4} hose clamps and {2} P/T fittings)	DORB1-90-4HC
1" MPT X Double O-Ring, 90° Elbow (includes {2} P/T fittings)	DORMP1-90
Quick Connect Cam Lock X Double O-Ring 90° Elbow	DORCL1-90
Male Garden Hose Thread X Double O-Ring (1-piece per box)	DORGHMT

NOTE: *All fittings boxed in pairs (2-pieces each) will exception of DORGHMT.*



**1-1/4" Socket Fusion X
Double O-ring
DORF125-S**



**1" Hose Barb X
Double O-ring
DORB1-S-4HC**



**1" MPT X Double O-ring
DORMP1-S**

PIPING INSTALLATION (CONTINUED)



**1" Swivel X Double O-ring
DORFP1-S**



**1" Copper Sweat X Double O-ring with 1/4"
FPT Port & Pressure/Temperature Test Plugs
DORS1-S**



**Elbow, 1" Hose Barb X Double
O-ring with 1/4" Port and
Pressure/Temperature Test Plugs
DORB1-90-4HC**



**Elbow, 1" MPT X Double
O-ring with 1/4" Port and
Pressure/Temperature Test Plugs
DORMP1-90**



**1" Cam Lever Male X
Double O-ring
DORCL1-90**



**Garden Hose Male X O-ring
(single) Adapter
DORGHMT**

NOTES:

1. Apply petroleum jelly to O-Rings to prevent damage and aid in insertion.
2. Use two (2) stainless steel clamps per connection (included quantities of hose clamps with fittings and hose kits are per this recommendation).
3. Adaptors required from 1" MPT, 1" FPT, Copper, etc. provided by others.

FIGURE 5A
FLOW CENTER CONNECTION TO GV SERIES MODEL

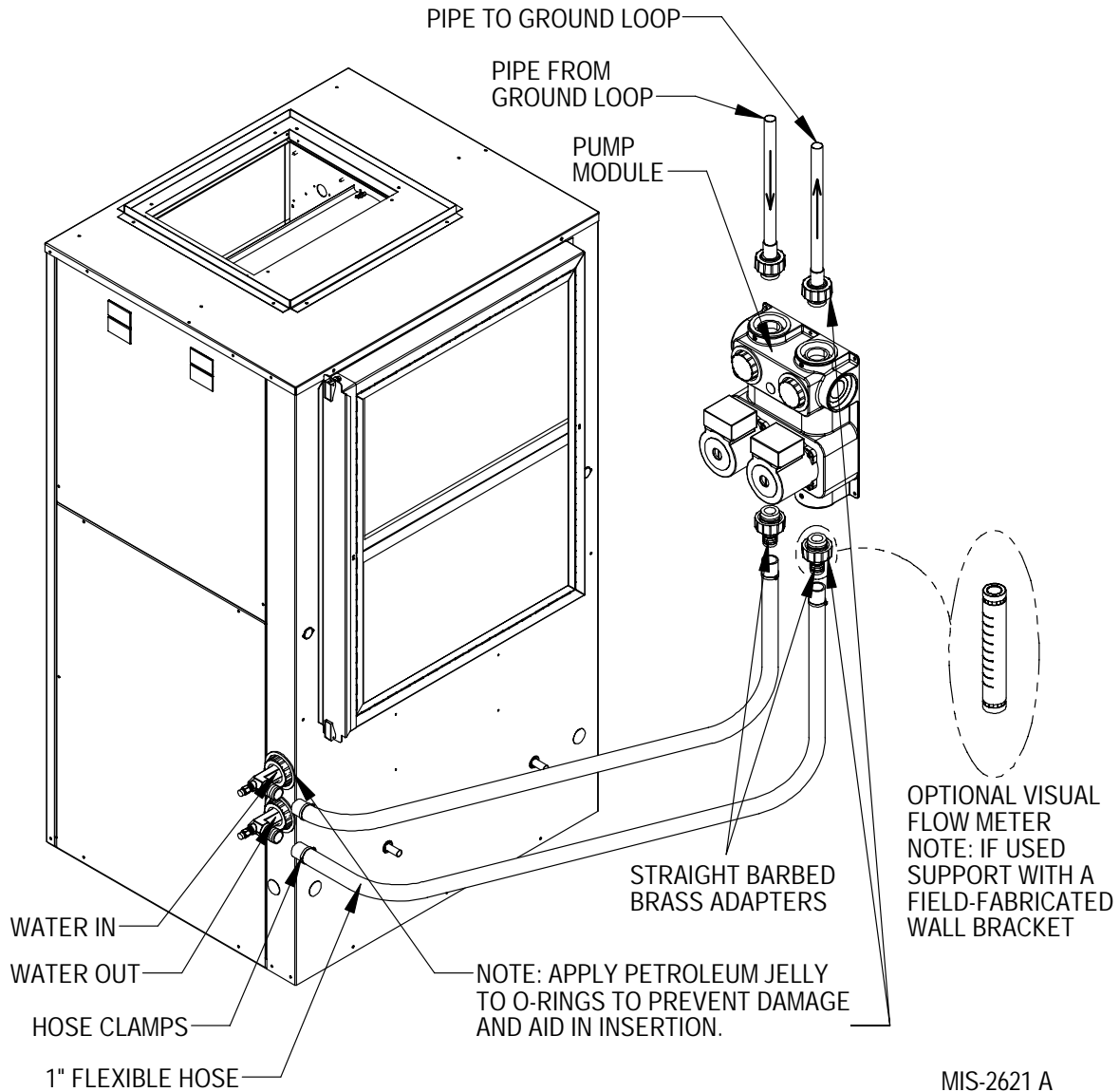

MULTIPLE UNIT TO SINGLE LOOP CONNECTION

In instances where multiple units are connected to a singular loop, our recommendation is to apply a flow center to each individual system with full-port balancing valves installed on each unit. See Figure 6.

**FIGURE 5B
FLOW CENTER CONNECTION TO GT SERIES MODEL**

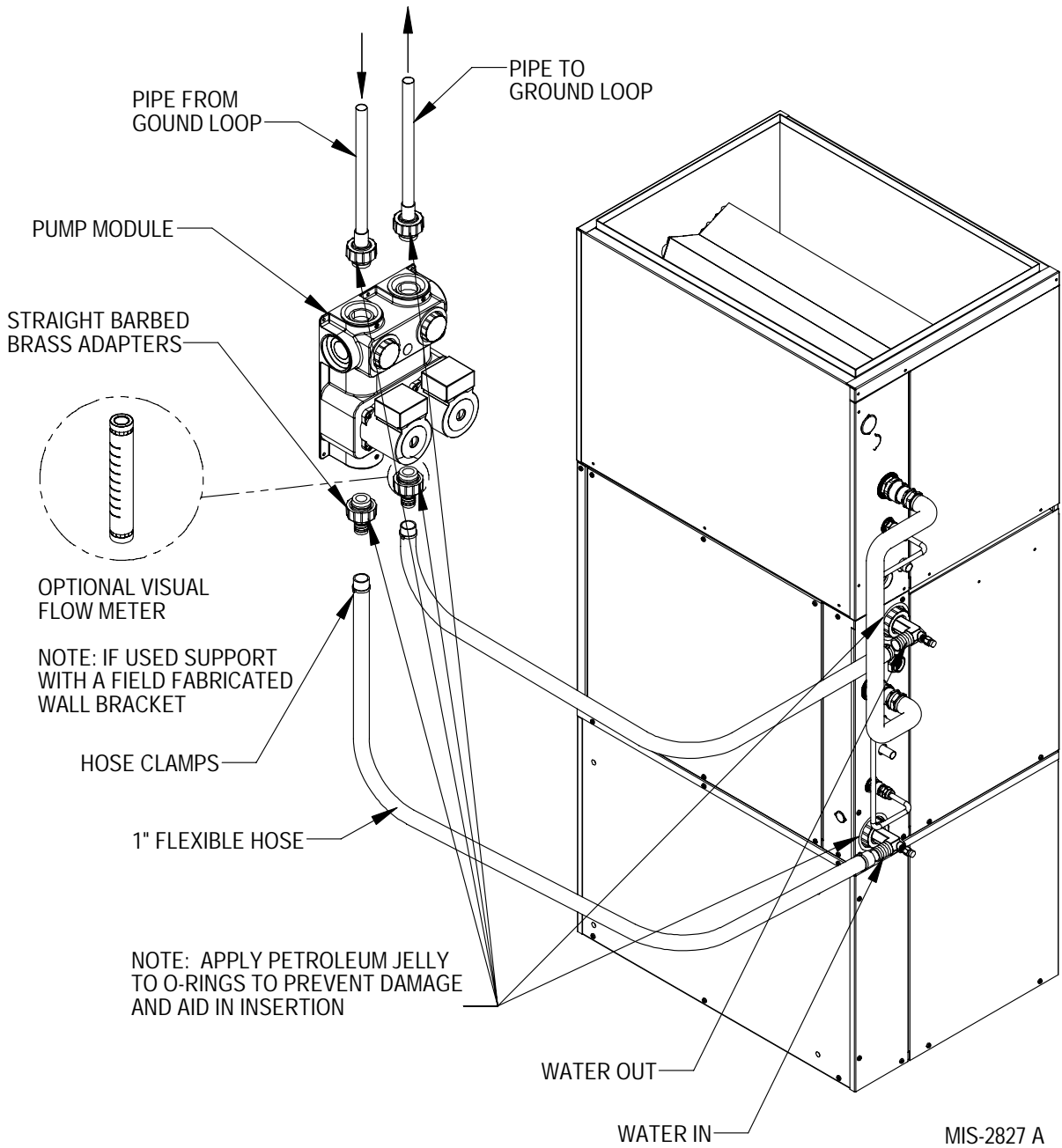
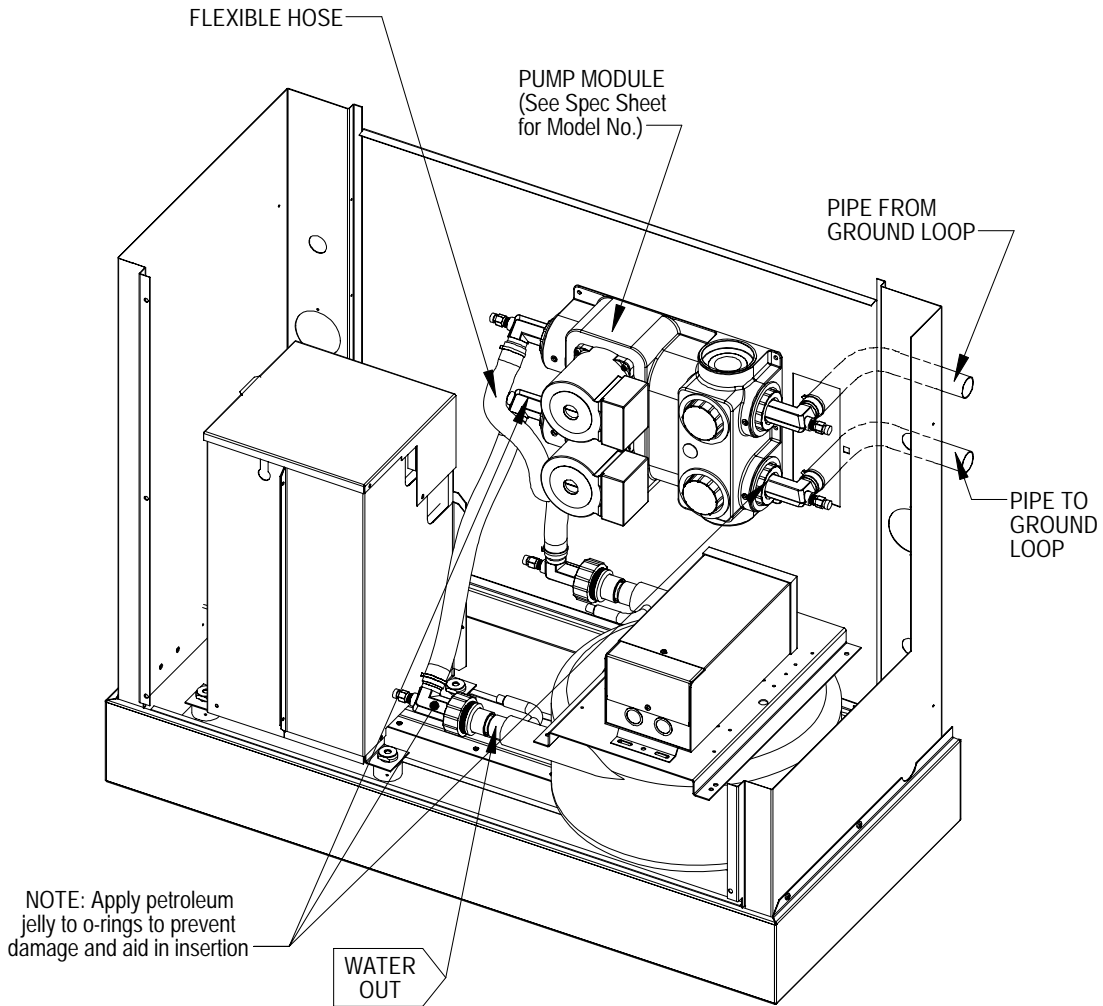
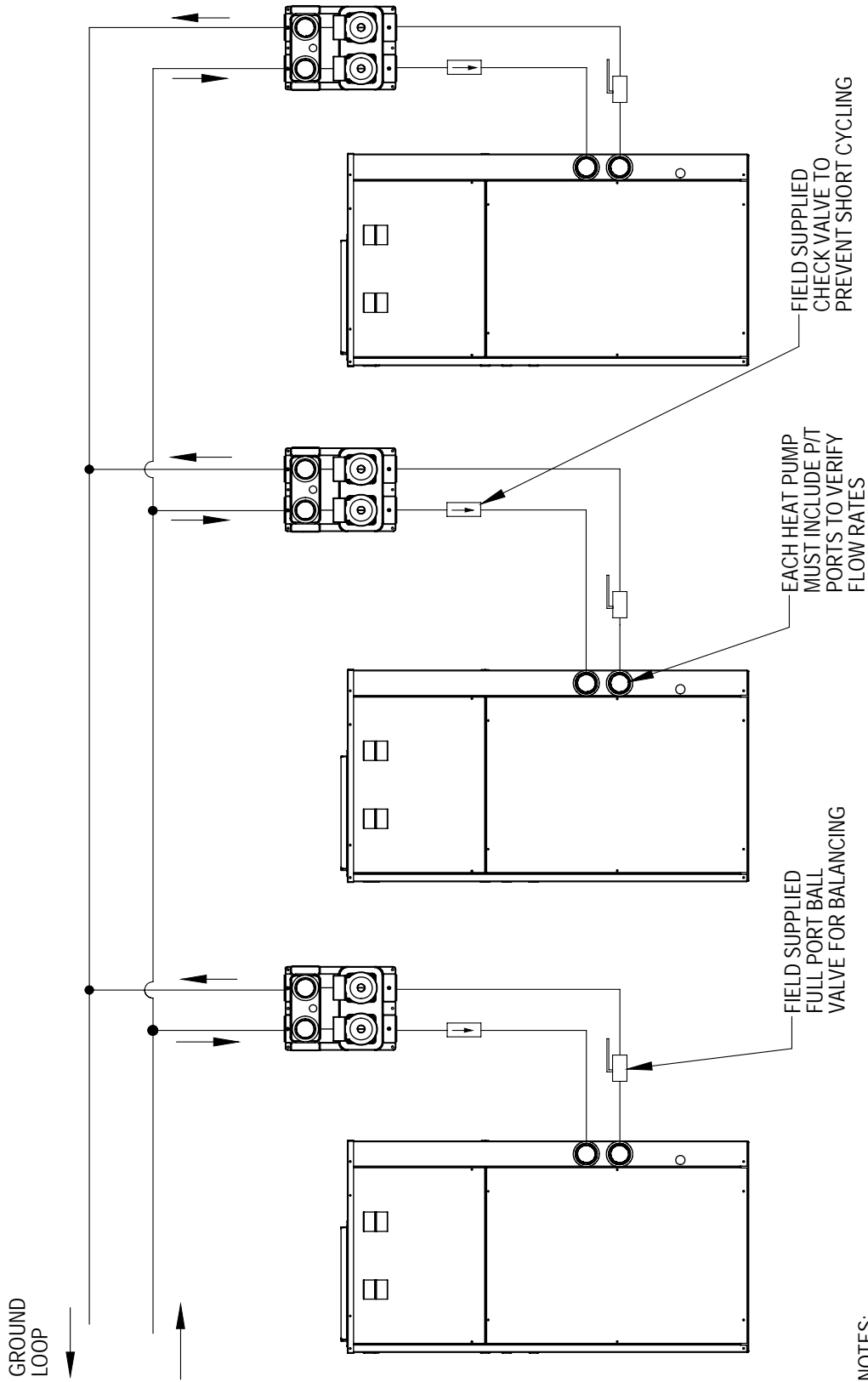

FIGURE 5C
FLOW CENTER CONNECTION TO QW SERIES MODEL



MIS-2748 A

**FIGURE 6
MULTIPLE UNIT CONNECTION TO SINGULAR GROUND LOOP**



NOTES:

1. Piping is shown schematically. Actual pipe diameter and layout must be determined before installation.
2. Pressure drop calculation must be made to verify that parallel pumping arrangement provides enough head to deliver design flow rate to each unit when all units are operating.
3. Flow controller should be mounted close enough to unit to maintain short (approx. 10 ft., 3m) hose kit from Flow Controller to unit.
4. All units must include P/T ports for flow rate measure and balancing.

MIS-2664

FLOW CENTER WIRING



WARNING

To avoid possible injury or death due to electrical shock, open the power supply disconnect switch and secure it in an open position during installation.



CAUTION

Use only copper conductors for field installed electrical wiring. Unit terminals are not designed to accept other types of conductors.

Power wiring to the Flow Center should conform to all applicable codes. Figure 7 shows the required wiring between the geothermal heat pump and the flow center. *NOTE: the flow center is only available in 208/230 Volt, 60 Hz, 1-phase.* The flow center electrical connection interior of the heat pump control panel is circuit breaker protected (both L1 and L2 power lines). See Table 2 for the electrical requirements.

**TABLE 2
ELECTRICAL RATINGS**

MODEL	PUMP QUANTITY	VOLTS	AMPS	HP
DORFC-1	1	230	1.07	1/6
DORFC-2	2	230	2.14	1/3

**FIGURE 7
ELECTRICAL CONNECTIONS**

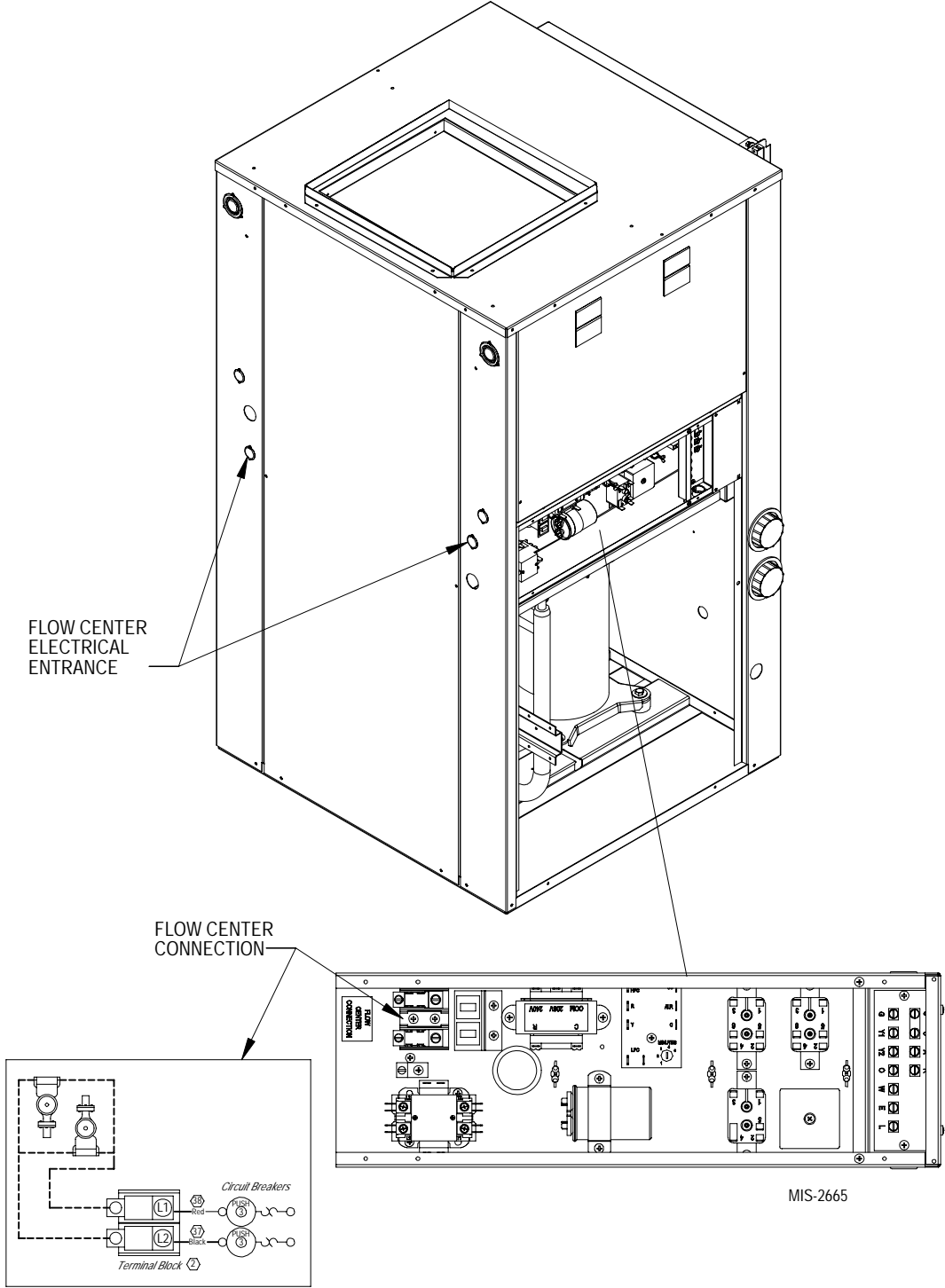

FLUSHING & CHARGING

All Flushing of earth loops should be performed using a 1.5 HP or larger pump (as specified by IGSHPA). Flushing can be accomplished using three different methods. The first flushing method applies a one-step installation of the loop, unit and inside piping. The second method allows a Loop Contractor to use flush cart when installing the loop, and at a later date, the dealer can install the unit to the loop using only domestic water to flush the unit. The third procedure shown is used when replacing the pump, coaxial refrigerant to water coil, or unit. The following are step-by-step procedures. *Be careful not to rotate the 3-way valves into a position where air can be introduced into the loop. Reflushing will be required if this occurs.* Valve position can be verified by looking on the end of the valve stem for the pattern position.

Consult the IGSHPA for more complete flushing and antifreeze instructions.

Flush in one direction for one hour, deadheading in increments - checking site glass for air pockets. Reverse flow in opposite direction, again for one hour, deadheading in increments - checking site glass for air pockets.

The presence of air can be detected by “deadheading” the pump. To deadhead the pump, close off the return to the pump and watch the water level site glass. Once you have no more than 1/2" to 3/4" drop in the site glass, you will have achieved complete air removal.

Power flushing can be achieved using the home’s city water supply (or well water) connected to the flush cart. This uses the combined pressure of the flush cart pump and the home’s water system for faster flushing.

After flushing is complete, but prior to unit start up, remove the large screw from the center of the flow center pump(s) to allow air to escape (water will drip out). Replace the screw after pump has filled with fluid.

For final pressurization, run the unit in heating or cooling for a period of 20 minutes. Following this 20 minute run time, pressurize the loop using the flush cart to 50-75 psig in winter or 40-50 psig in summer.

In areas where entering loop temperatures drop below 40°F (5°C) or where piping will be routed through areas subject to freezing, antifreeze is needed to prevent the loop from freezing inside the pipe or heat exchanger. Alcohols and glycols are commonly used as antifreeze, however, you should consult with your distributor for assistance in selecting the antifreeze best suited for your region.

PROCEDURES FOR ADDING ANTIFREEZE

1. Flush cart should be half full of water.
2. Add measured amount of antifreeze through hose below the water level (calculate based upon loop).
3. Add antifreeze to loop side only (see valve position in Figure 9A).
4. Pump and dump (discharge).
5. Turn off pump; close discharge valve.
6. Repeat the procedure to add remaining antifreeze to loop.

FLUSHING & CHARGING (CONTINUED)

FIGURE 8
CONNECTING FLUSH CART TO FLOW CENTER

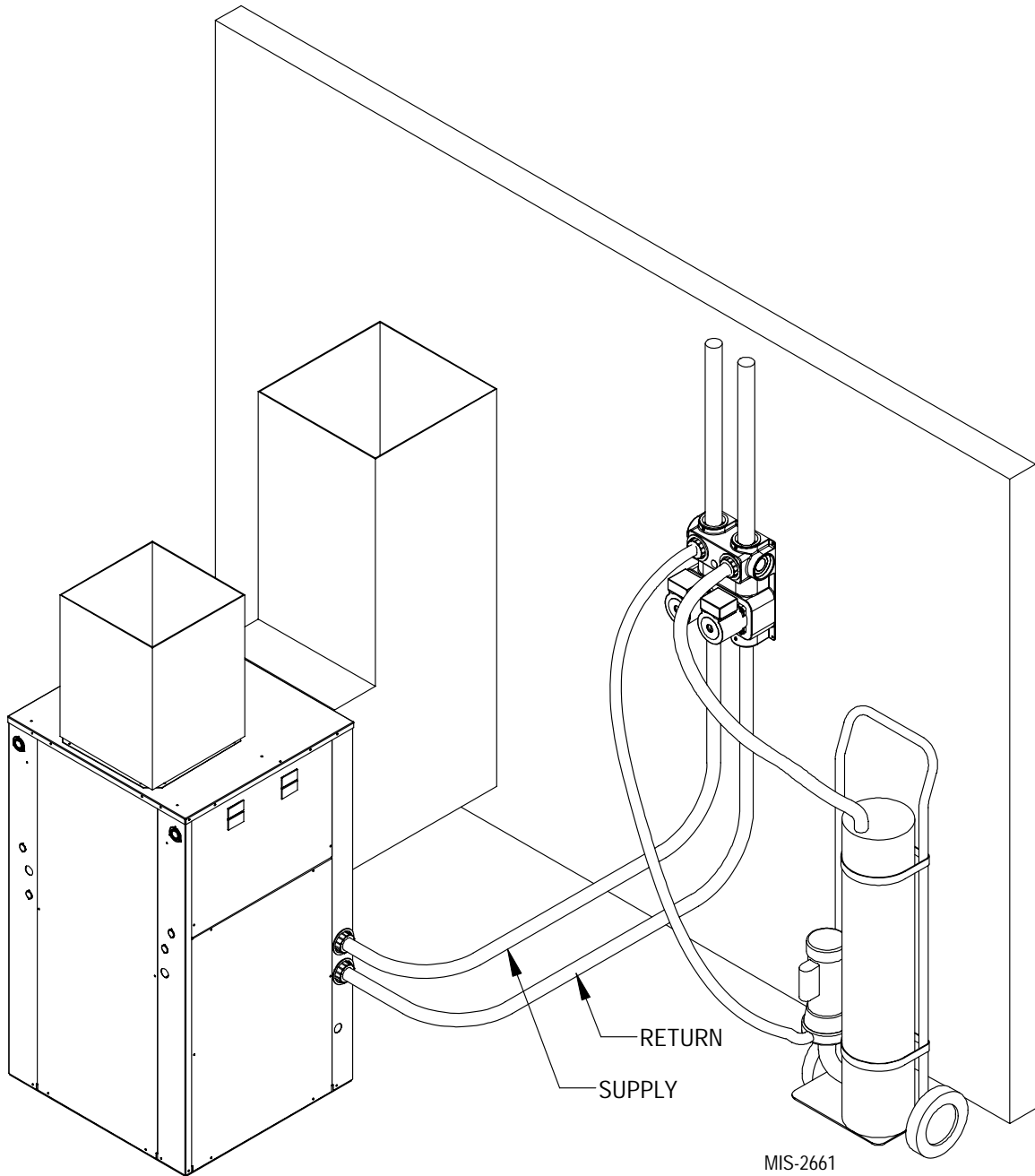

FLUSHING & CHARGING (CONTINUED)

FIGURES 9A & 9B
FLOW CENTER VALVE POSITIONING

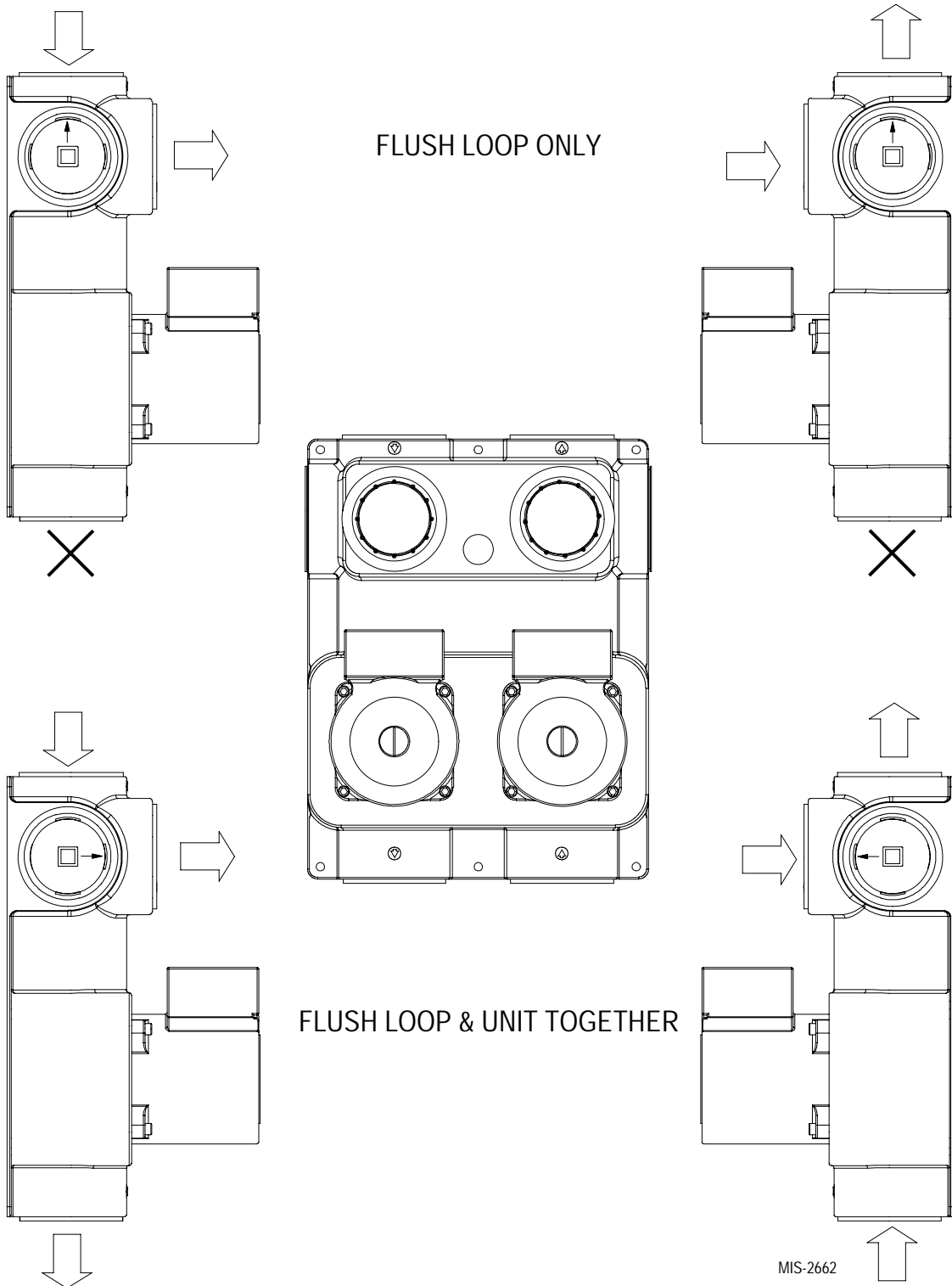

FLUSHING & CHARGING (CONTINUED)

FIGURES 9C & 9D
FLOW CENTER VALVE POSITIONING

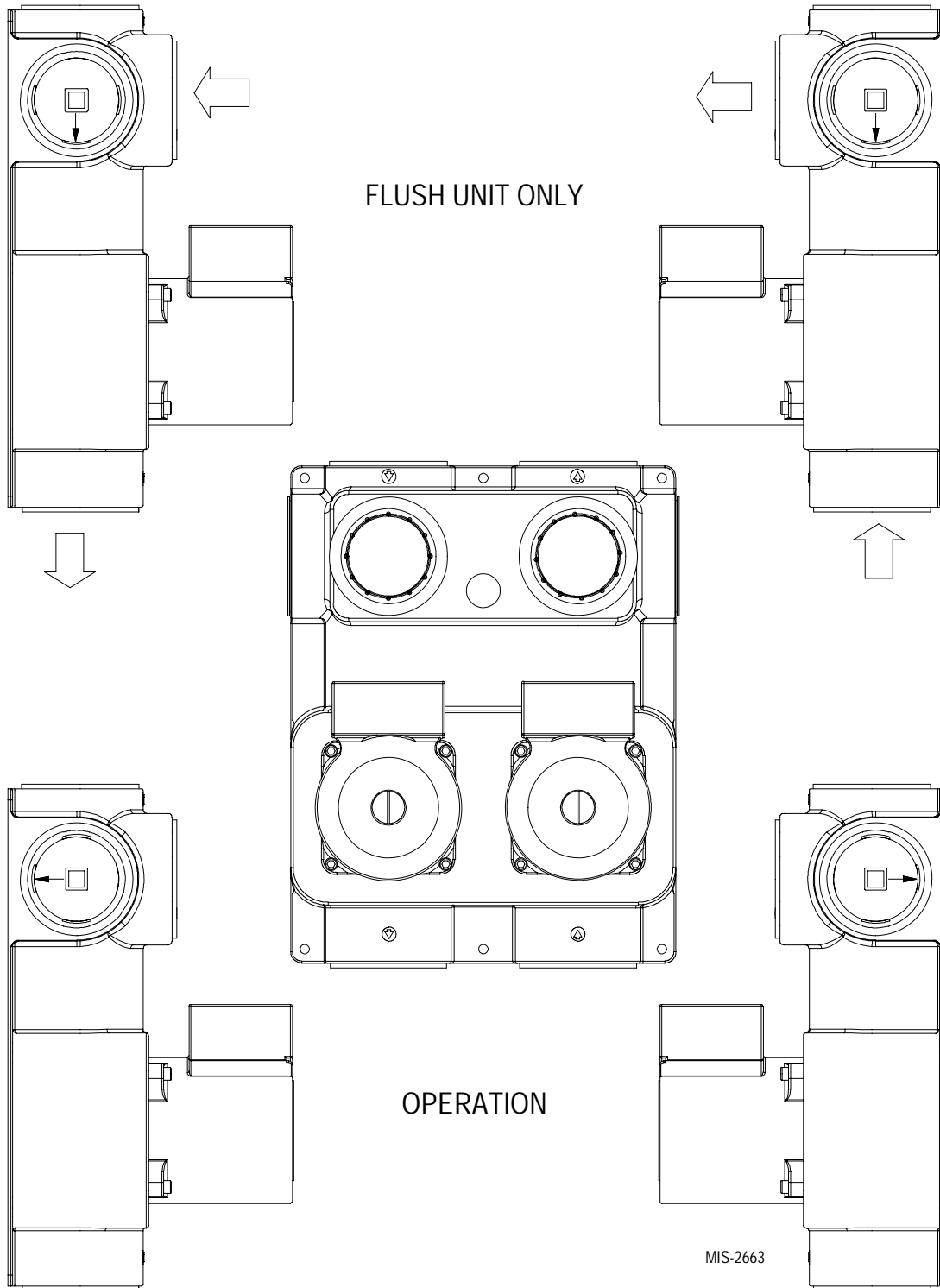

FLUSHING & CHARGING (CONTINUED)

FLUSHING & FILLING EARTH LOOP AND UNIT(S) TOGETHER

All air and debris must be removed from the earth loop piping system before operation. Flush the loop with a high volume of water at a high velocity (2 fps in all piping in accordance with IGSHPA guidelines).

1. Connect the unit and loop to the flow center.
2. Connect the flush cart hoses to the front port of the flow center (see Figure 8).
3. Fill closed loop (outside) evenly with domestic water and discharge the return water by adding water to the flush cart until water returns to the reservoir. The return water should be filtered or discharged to remove debris.
4. Fill the flush cart two-thirds full for initial flushing.
5. Flush the lowest portion of the system first. Depending upon the individual layout, this could be the loop or the unit. (If unit is lowest part of system, set valve position as shown in Figure 9C. If loop is lowest part of system, set flow center valve position as shown in Figure 9A.)
6. Restart the pump. Once you have a steady flow of water on the return side from the system, deadhead the pump by closing the ball valve on the hose returning to the reservoir. This will generate the maximum pressure on the system. While the return ball valve is closed, note the fluid level in the reservoir. If all the air is purged from the system, the level will drop only 1/2" to 3/4" in the flush cart site glass, since water is not compressible. ***This is the only way to tell if the air is purged from the system.*** Open valve quickly, wait one minute, then deadhead again. Repeat this process until all air is purged from the system.
7. Reverse the flow direction with the flush cart and repeat Step #6.
8. Repeat Step #6 for the higher elevation side of the system. (If unit is highest part of system, set valve position as shown Figure 9C. If loop is highest part of system, set flow center valve position as shown in Figure 9A.)
9. After flushing both sides of the system, reset flow control valves to flush the entire system. Set valve position as shown in Figure 9B and repeat Step #7.

FLUSHING EARTH LOOP ONLY

1. Connect loop to flow center.
2. Connect the unit side connections of the flow center together with a jumper hose.
3. Remove caps and plugs from flow center front access ports.
4. Connect flush cart hoses to access ports.
5. Position valve stems as shown in Figure 9A.
6. Fill the flush cart two-thirds full for initial flushing.
7. Restart the pump. Once you have a steady flow of water on the return side from the system, deadhead the pump by closing the ball valve on the hose returning to the reservoir. This will generate the maximum pressure on the system. While the return ball valve is closed, note the fluid level in the reservoir. If all the air is purged from the system, the level will drop only 1/2" to 3/4" in the flush cart site glass, since water is not compressible. ***This is the only way to tell if the air is purged from the system.*** Open valve quickly, wait one minute, then deadhead again. Repeat this process until all air is purged from the system.
8. Reverse the flow direction with the flush cart and repeat Step #7.
9. Rotate the flow center valves to isolate the flush cart from the rest of the system (see Figure 9C).
10. Turn off flush cart pump, relieve pressure on the hoses and remove them.
11. Replace flow center access plugs and caps.
12. Rotate valves back to position as shown in Figure 9B.
13. Remove jumper from unit connection ports.

FLUSHING & CHARGING (CONTINUED)

FLUSHING UNIT ONLY (ALSO USED WHEN REPLACING UNIT, COAXIAL COIL, HOSE KIT OR PUMP)

1. Connect unit to flow center.
2. Rotate 3-way valve to position shown in Figure 9C.
3. Remove access port caps and plugs and connect either flush cart or Bard DORGHMT fitting (service only - not intended for primary flush).
4. Attach garden hose to domestic water supply.
5. Purge air from garden hose before connecting to port in flow center.
6. Attach another length of garden hose to the other port in the flow center, leading to drain.
7. Flush flow center and unit with domestic water until air is removed.
8. Close drain valve on discharge hose and pressurize system to domestic water pressure (approx. 4-75 psig).
9. Remove bleed screw(s) from flow center pump motors to purge air and replace screw(s).
10. Close valve on supply hose to trap pressure in the system.
11. Rotate 3-way valves back to normal operating position (see Figure 9D).
12. Remove water supply hose from flow center and replace access port caps/plugs.

FLOW CENTER INITIAL STARTUP

1. Check to make sure the loop and unit isolation valves are completely open and the flush ports are closed and sealed (see Figure 9D).
2. Geothermal units have two low pressure switches installed. One switch is intended for Ground Water Applications (default factory wired - blue wires), and the second is intended for Ground Loop Applications (yellow wires). Remove the “blue” wires from the LPS terminals of the compressor control module internal of the control panel of the geothermal heat pump and replace with the yellow low pressure switch wires (see unit wiring diagram).
3. Check and record the earth loop pressure (use P/T ports at geothermal heat pump).
Loop Pressure ____ IN ____ OUT
4. Check and record flow rate.
FLOW RATE - ____ GPM
5. Check performance of unit. (Refer to Geothermal Heat Pump Installation Manual.)

PROCEDURE FOR PRESSURIZING THE SYSTEM

1. Once system is completely flushed and antifreeze is added, it can then be pressurized. Perform this by deadheading the pump by closing the return hose ball valve. This will increase the pressure on the loop via the flush cart pump. As the pressure will fluctuate with the seasons (set higher in winter and lower in summer), it is suggested that the initial loop pressure be 50-75 psig in winter and 40-50 psig in summer. If you cannot reach these pressures with the flush cart pump alone, turn on the fresh water feed to the cart while still deadheading the pump. The potable water pressure, along with the pump, will increase the amount of pressure in the loop.
2. Bleed any air from the inside of the pump. This can be done by removing the bleed screw from the center of the pump motor head, allowing a small amount of fluid to drip out. Replace the bleed screw.
3. Rotate the flow center valves to isolate the flush cart from the rest of the system (see Figure 9D).
4. Turn off the flush cart pump, relieve the pressure on the hoses and remove them.
5. Replace flow center access plugs and caps.

NOTE: If the flow center is mounted in the horizontal position, the supply hose must be connected to the lower flushing port to allow air to pass out of the upper port during the final flushing.

PRESSURE/TEMPERATURE PLUGS

The pressure/temperature plugs (P/T plugs) supplied with the ground water connectors are provided as a means of measuring flow and temperature (see Figure 10). The waterflow through the unit can be checked by measuring the incoming water pressure at the supply pressure P/T and subtracting the leaving water pressure at the return water P/T plug. Comparing the differential to the pressure drop/flow chart (Table 3) will determine the flow rate through the heat pump.

Example: Model GV51S1 with a measured pressure drop of 5.1 psig is equivalent to 9 GPM flow.

GPM rates higher than the required minimum flow rates will not be detrimental to performance. However, insufficient flow can significantly reduce capacity, efficiency and create nuisance trips of safety controls, and possibly damage to components in extreme conditions.

NOTE: Pressure/Temperature probes should be lubricated with a water-based lubricant prior to gently pushing the probes into the P/T ports to prevent internal damage. Thermometers, probes and gauges are available for conducting these tests.

**FIGURE 10
PRESSURE TEMPERATURE PORTS**

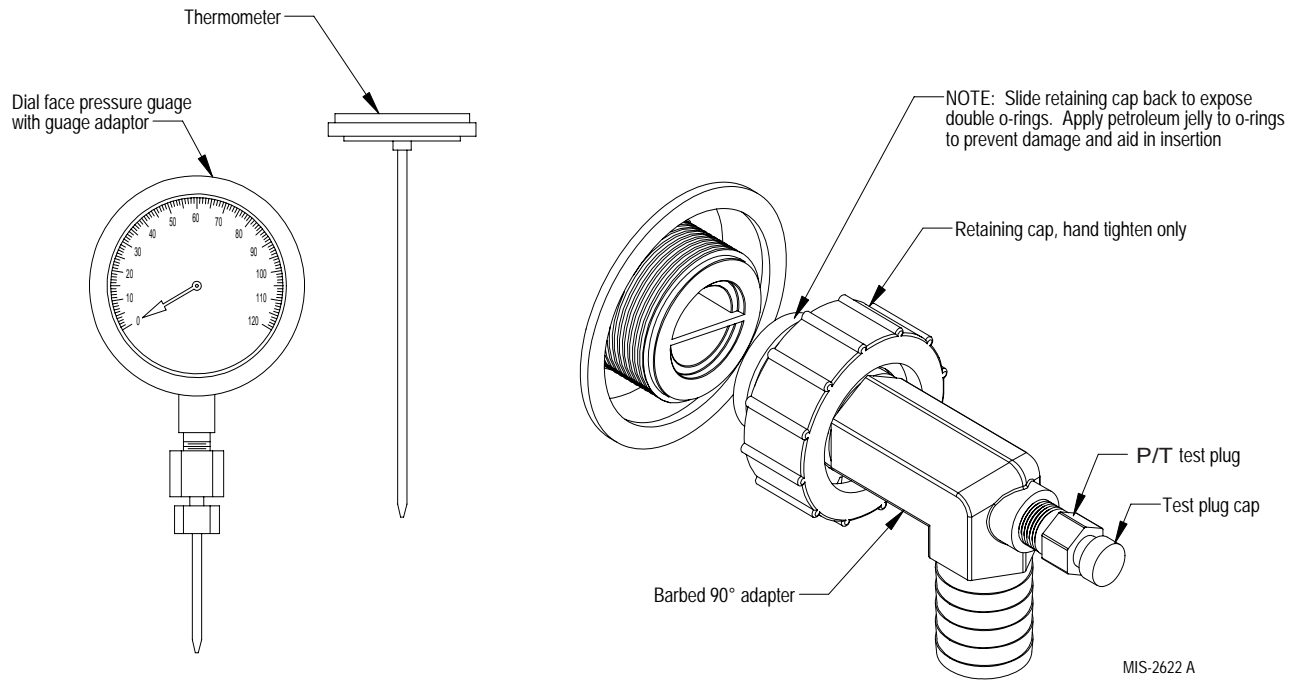

**TABLE 3A
GV SERIES COIL PRESSURE DROP**

Model	GV27S1		GV38S1 / GV51S1		GV61S1		GV71S1		
	GPM	PSID	Ft. Hd.	PSID	Ft. Hd.	PSID	Ft. Hd.	PSID	Ft. Hd.
3		0.1	0.23						
4		0.5	1.15	0.9	2.08				
5		1.2	2.77	1.4	3.23				
6		1.7	3.92	2.3	5.31				
7		2.3	5.31	3.2	7.38	2	4.61		
8		3.1	7.15	4.1	9.46	2.5	5.77	2	4.61
9		4.1	9.46	5.1	11.77	3.2	7.38	2.4	5.54
10				6.1	14.07	3.9	9.00	2.8	6.46
11				7.1	16.38	4.7	10.84	3.4	7.84
12				8.2	18.92	5.5	12.69	3.9	9.00
13				9.4	21.69	6.4	14.76	4.5	10.38
14				10.6	24.45	7.3	16.84	5.2	12.00
15						8.1	18.69	5.9	13.61
16						9	20.76	6.7	15.46
17						9.9	22.84	7.4	17.07
18								8.4	19.38

**TABLE 3B
GT SERIES COIL PRESSURE DROP**

Model	GTC36S1		GTC48S1		GTC60S1	
	PSID	Ft. Hd.	PSID	Ft. Hd.	PSID	Ft. Hd.
3	0.1	0.23				
4	0.5	1.15	0.9	2.08		
5	1.2	2.77	1.4	3.23		
6	1.7	3.92	2.3	5.31		
7	2.3	5.31	3.2	7.38	2	4.61
8	3.1	7.15	4.1	9.46	2.5	5.77
9	4.1	9.46	5.1	11.77	3.2	7.38
10			6.1	14.07	3.9	9.00
11			7.1	16.38	4.7	10.84
12			8.2	18.92	5.5	12.69
13			9.4	21.69	6.4	14.76
14			10.6	24.45	7.3	16.84
15					8.1	18.69
16					9	20.76
17					9.9	22.84
18						

**TABLE 3C
QW SERIES COIL PRESSURE DROP**

GPM	QW2S1 & QW3S1		QW4S1		QW6S1	
	PSIG	Ft. Hd.	PSIG	Ft. Hd.	PSIG	Ft. Hd.
3	0.1	0.23				
4	0.5	1.15	0.9	2.08		
5	1.2	2.77	1.4	3.23		
6	1.7	3.92	2.3	5.31		
7	2.3	5.31	3.2	7.38	2	4.61
8	3.1	7.15	4.1	9.46	2.5	5.77
9	4.1	9.46	5.1	11.77	3.2	7.38
10			6.1	14.07	3.9	9.00
11			7.1	16.38	4.7	10.84
12			8.2	18.92	5.5	12.69
13			9.4	21.69	6.4	14.76
14			10.6	24.45	7.3	16.84
15					8.1	18.69
16					9	20.76
17					9.9	22.84
18						

TROUBLESHOOTING

Problem	Possible Causes	Checks & Corrections
Water Drips Out	Condensation	Insulate piping, check for insulation gaps.
	Water Leak	Inspect/tighten fittings.
Low Flow / No Flow	Power Loss	Check power supply from the heat pump.
	Blown Circuit Breaker	Reset circuit breaker for flow center in heat pump control box.
	Broken or Loose Wires	Replace or tighten wires.
	Pump Shaft Stuck	Remove the indication plug and ensure that shaft is rotating.
	Air Lock	Flush loop to eliminate air.
	Improperly Sized Pump	Add pump capacity.
	Defective Pump	Replace.
	No Positive Pressure	Check for leaks, add fluid, flush as required and pressurize.
	Viscous Solution	Change type of antifreeze.
	Loop Freezing or Frozen	Switch thermostat to A/C operation to see if flow improves at warmer temperature. Add antifreeze and measure freeze protection.
	Kink in Loop	Straighten or Replace.
Noisy	Defective Pump	Replace.
	Air in Loop	Flush loop again.
	Vibration	Check mounting.
Pressure Loss	Leak	Repair.
	Temperature Change	Not a problem; pressure should vary as temperature changes.
	Pipe Expansion	Not a problem; plastic piping relaxing.
Unit Trips Out on Water Flow (Low Pressure or High Pressure)	Low Flow / No Flow	See Low Flow / No Flow.

ANTIFREEZE SELECTION & USE

Selection of antifreeze solutions for ground loop applications requires consideration of many important factors, which may have long-term implications in regards to performance and system component life. Each area of concern leads to a different antifreeze solution. The fact that there is no “ideal” antifreeze and any choice will require compromises in one area or another. Some of these considering factors include:

Safety – The toxicity and flammability of the antifreeze solution.

Thermal Performance – The heat transfer and viscosity effects of the antifreeze.

Cost – The prices vary widely.

Corrosiveness – System materials must be compatible with the antifreeze solution.

Stability – Will the solution require periodic change out or maintenance?

Convenience – Is the solution readily available and easy to transport and install?

Codes – Will the solution meet local/regional/state/national regulatory standards?

It is highly recommended to utilize pre-mixed antifreeze solutions where possible to alleviate many installation problems and extra labor.

The following are some general observations about the types of antifreeze materials presently being applied in the geothermal ground loop markets:

Methanol – Considered toxic in pure form, good heat transfer, low to mid-price, flammable in concentrations greater than 25%, non-corrosive and low viscosity. Methanol has delivered outstanding performance in ground loop applications for over 20 years. Its only drawbacks are toxicity and flammability. Although methanol enjoys widespread consumer use as windshield washer fluid in even higher concentrations, some local codes may limit its use in ground loops. (*Note: Do NOT use automotive windshield washer fluid as antifreeze. Most washer fluids contain chemicals that will cause foaming.*) To increase safety, a pre-mixed form should be used on the jobsite to increase the safety factor. Pure methanol can be purchased from any chemical supplier.

Ethanol – Good heat transfer (lower than methanol), high price, flammable in concentrations greater than 10%, non-corrosive and low viscosity. Ethanol in pure form is considered non-toxic and shows promise as a geothermal heat transfer fluid. However, the U.S. Bureau of Alcohol, Tobacco & Firearms (ATF) limit its distribution. All non-beverage ethanol is required to be denatured and rendered unfit to drink. Generally, this is done by adding a small percentage of toxic substances such as methanol, benzene or gasoline as a denaturant. Many of the denaturants are difficult to identify by the casual user, and many are not compatible with polyethylene pipe. Only denatured ethanol can be purchased for commercial use. The use of ethanol is not recommended because of the unknown denaturants included in the solution and their possible toxicity and damage resulting to polyethylene piping systems. Denaturing agents that are petroleum based can damage polyethylene pipe.

ANTIFREEZE SELECTION & USE (CONTINUED)

Propylene Glycol – Non-toxic, non-corrosive, expensive, hard to handle when cold, poorest heat transfer, has formed “slime-type” coatings inside system piping. Propylene Glycol is acceptable in systems anticipating loop temperatures no colder than 40°F (4.4°C). These systems typically use antifreeze because of low ambient conditions (outside plumbing or cooling tower, etc.). When loop temperatures are below 40°F, the fluid becomes very difficult to pump and heat transfer characteristics suffer greatly. Only food grade propylene glycol is recommended to prevent the corrosion inhibitors from reacting with local water causing “slime-type” coatings inside heat exchangers. If propylene glycol must be used (code requirements), careful consideration of loop Reynolds numbers, pump selection and pressure drop must be considered.

Potassium Acetate (GS4) – Non-toxic, good heat transfer, high price, non-corrosive with added inhibitors, low viscosity. Due to its low surface tension, Potassium Acetate has been known to leak through mechanical fittings and certain thread sealants. A variant of the salt family, it can be extremely corrosive when exposed to air. Potassium Acetate is not recommended in ground loop applications due to the leaking and (ultimately) corrosion problems associated with it.

NOTE: Consult with your local distributor if you have questions regarding antifreeze selection and any comments to report about problems or success with any particular methods in your area.

**TABLE 4
FLUID VOLUME**

Approximate Fluid Volume per 100' (10 Meters) of Pipe

TYPE	SIZE	VOLUME (U.S. GALLON/100'PIPE)	VOLUME (LITERS/10 METERS)
Copper	1" CTS	4.1	15.5
Copper	1-1/4" CTS	6.4	24.2
Copper	1-1/2" CTS	9.2	34.8
Polyethylene	3/4" - IPS SDR 11	3.0	11.4
Polyethylene	1" - IPS SDR 11	4.7	17.8
Polyethylene	1-1/4" - IPS SDR 11	7.5	28.4
Polyethylene	1-1/2" - IPS SDR 11	9.8	37.1
Polyethylene	2" - IPS SDR 11	15.4	58.3

**TABLE 5
PERCENTAGES BY VOLUME**

Antifreeze Percentages by Volume

TYPE	MINIMUM TEMPERATURE FOR FREEZE PROTECTION			
	10°F (-12.2°C)	15°F (-9.4°C)	20°F (-6.7°C)	25°F (-3.9°C)
Methanol	25%	21%	16%	10%
Ethanol *	29%	25%	20%	14%
100% USP Food Grade Propylene Glycol	27%	24%	20%	13%

* Must not be denatured with any petroleum based product.



WARNING

Always use properly marked vehicles (D.O.T. placards) and clean/suitable/properly marked identified containers for handling flammable antifreeze mixtures. Post and advise those on the jobsite of chemical use and potential dangers of handling and storage.



CAUTION

Always obtain MSDS (material safety data sheets) for all chemicals used in ground loop applications - including chemicals used as antifreeze.

ANTIFREEZE VERIFICATION

Both Glycol and Alcohol based antifreeze solutions can be verified to the specific percentage of volume within the ground loop system. One of the easiest ways to check this is through use of a Hydrometer to check the specific density of the ground loop fluid and comparing these to the charts supplied by the antifreeze manufacturer (see Figure 11).

Hydrometers can be purchased from your local distributor and are also available through national wholesalers.

FIGURE 11
DENSITY VERIFICATION
for SOLUTION STRENGTH

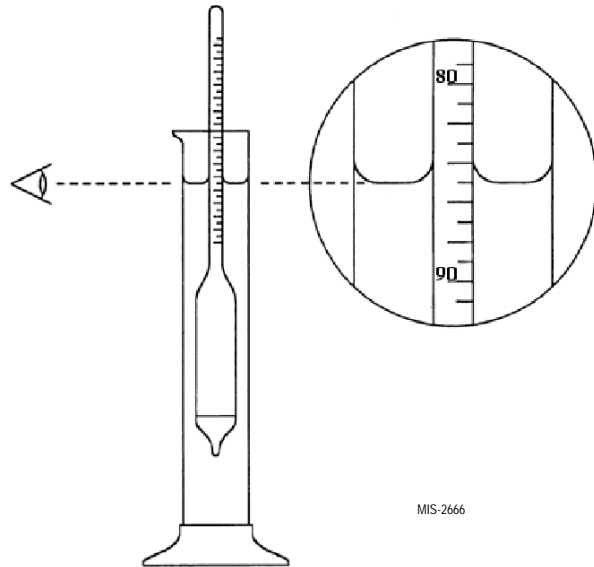

TABLE 6

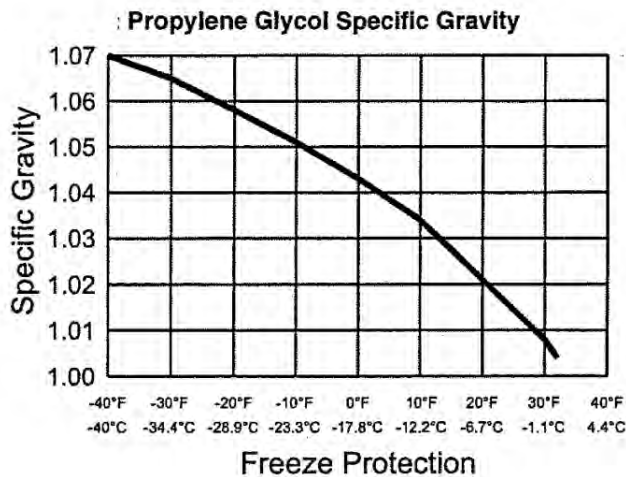
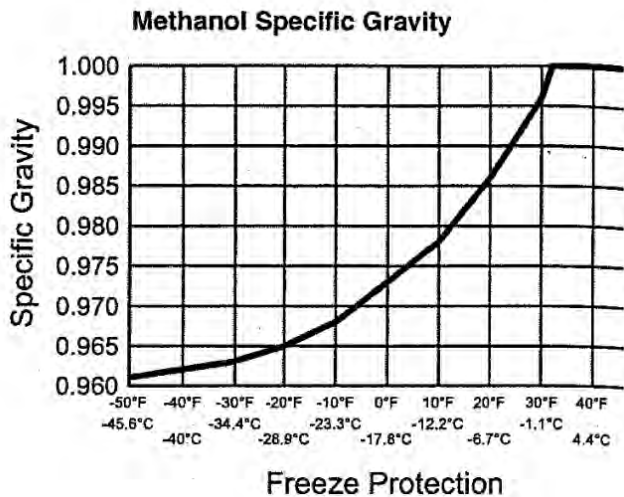

TABLE 7



It is recommended that IGSHPA design and specifications are utilized for Loop Design, Pipe Manifolding and Hot Fusion operations.

There are many available software programs available to aid with loop design parameters. Your local loop material or equipment supplier may have this technology available. Technical Service has the capability to assist you in this area as well, but it is on a first come - first serve basis.