

---

# INSTALLATION INSTRUCTIONS

---

## ECONOMIZERS WITH EXHAUST FOR EQUIPMENT BUILDING APPLICATIONS

Models:

WGCRVS-3A

WGCRVP-3A

WGCRVS-5A

WGCRVP-5A



*Climate Control Solutions*

Bard Manufacturing Company, Inc.  
Bryan, Ohio 43506  
[www.bardhvac.com](http://www.bardhvac.com)

Manual : 2100-524B  
Supersedes: 2100-524A  
Date: 3-19-15

# CONTENTS

---

## **WG General Information**

General Information.....	3
Unpacking.....	3
Description.....	3
Features.....	3
Sequence of Operation.....	3

## **Installation**

Basic Installation.....	6
Ventilator Checkout.....	9
Wiring Diagrams.....	15

## **Figures**

Figure 1	Call for Blower Operation w/o Vent.....	4
Figure 2	Call for Ventilation.....	5
Figure 3	Removal of Vent Option Panel.....	6
Figure 4	Loose Piece Wire Harness Plug Install.....	7
Figure 5	Ventilator Installed in Unit.....	8
Figure 6	Locating Blade Stop.....	9
Figure 7	Thermostat Diagram.....	13
Figure 8	Gas Electric Connection.....	14
Figure 9	CRVP Wiring Diagram.....	15
Figure 10	CRVS Wiring Diagram.....	16

## **Charts**

W24G CRV Airflow (Low, Medium, High).....	10
W30-36G CRV Airflow (Low, Medium, High).....	11
W42-60G CRV Airflow (Low, Medium, High).....	12

## GENERAL INFORMATION

The ventilator should only be installed by a trained heating and air conditioning technician. These instructions serve as a guide to the technician installing the ventilator package. They are not intended as a step-by-step procedure with which the mechanically inclined owner can install the package.

The ventilator housing is shipped in one carton which contains the electrical harness, miscellaneous hardware and installation instructions.

## UNPACKING

Upon receipt of the equipment, be sure to compare the model number found on the shipping label with the accessory identification information on the ordering and shipping document to verify that the correct accessory has been shipped.

Inspect the carton housing of each ventilator as it is received. Before signing the freight bill, verify that all items have been received and that there is no visible damage. Note any shortages or damage on all copies of the freight bill. The receiving party must contact the last carrier immediately, preferably in writing, requesting inspection by the carrier's agent. Concealed damage not discovered until after loading must be reported to the carrier within 15 days of its receipt.

## DESCRIPTION

The ventilators are designed to be used with Bard 2 ton through 5 ton wall mount gas electric units. They are electromechanical vent systems designed to provide fresh air to meet indoor air quality standards with built in exhaust provisions.

## FEATURES

- One piece construction: Easy to install with no mechanical linkage adjustment required.
- Exhaust air damper: Built in with positive closed position. Provides exhaust air capability to prevent pressurization of tight buildings.
- **WGCRVS Model** Actuator motor – 24 volt, power open, spring return with built-in torque limiting switch.
- **WGCRVP Model** Actuator motor – 24 volt, power open, power close with built-in torque limiting switch.
- Provides up to 75% of outside air.

## SEQUENCE OF OPERATION

When no ventilation call is present, ventilation damper remains closed and conditioned air is 100% return air (see Figure 1 on page 4).

On a call for ventilation, control room ventilator (CRV) opens to full open position as set by minimum position potentiometer and energizes comfort air blower (see Figure 2 on page 5).

**FIGURE 1**  
**Call for Blower Operation**  
**without Ventilation**

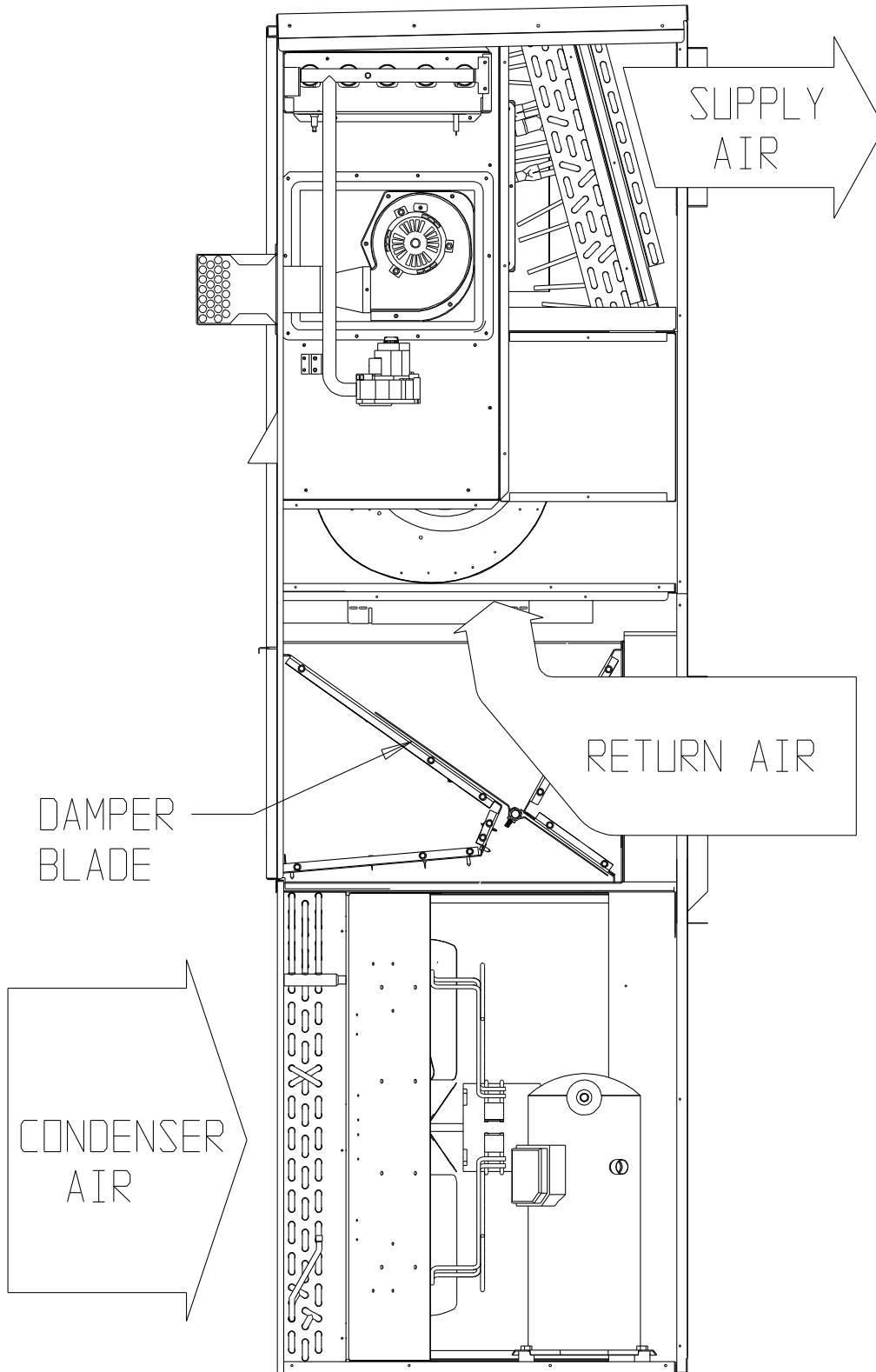

MIS-2412

**FIGURE 2**  
**Call for Ventilation**

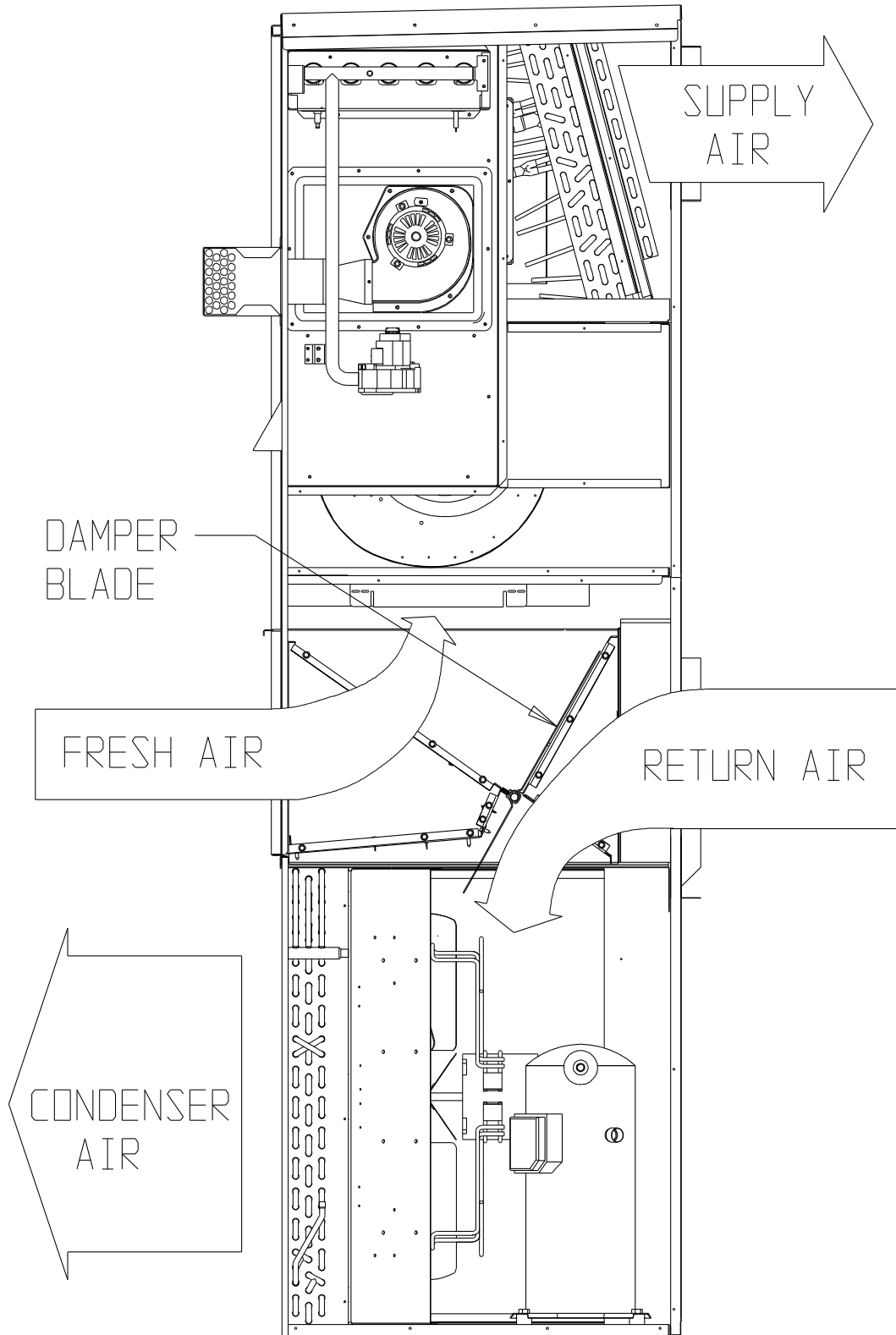

MIS-2413

# INSTALLATION

## BASIC INSTALLATION

1. Unpack the ventilator assembly which includes the integral ventilator with attached electrical harness and miscellaneous hardware.



## WARNING

Open and lock unit disconnect switch before installing this accessory to prevent injury or death due to electrical shock or contact with moving parts. Turn thermostat to off.

2. Open the front door. Remove and save vent option panel from wall mount unit (see Figure 3).
3. Remove and save existing unit air filter and screw from front center grille.
4. Remove and discard the exhaust cover plate.
5. Install the replacement exhaust cover plate with screen that is included with the kit.
6. Install loose piece wire harness shipped with kit (as shown in Figure 4).

**FIGURE 3**  
Removal of Vent Option Panel

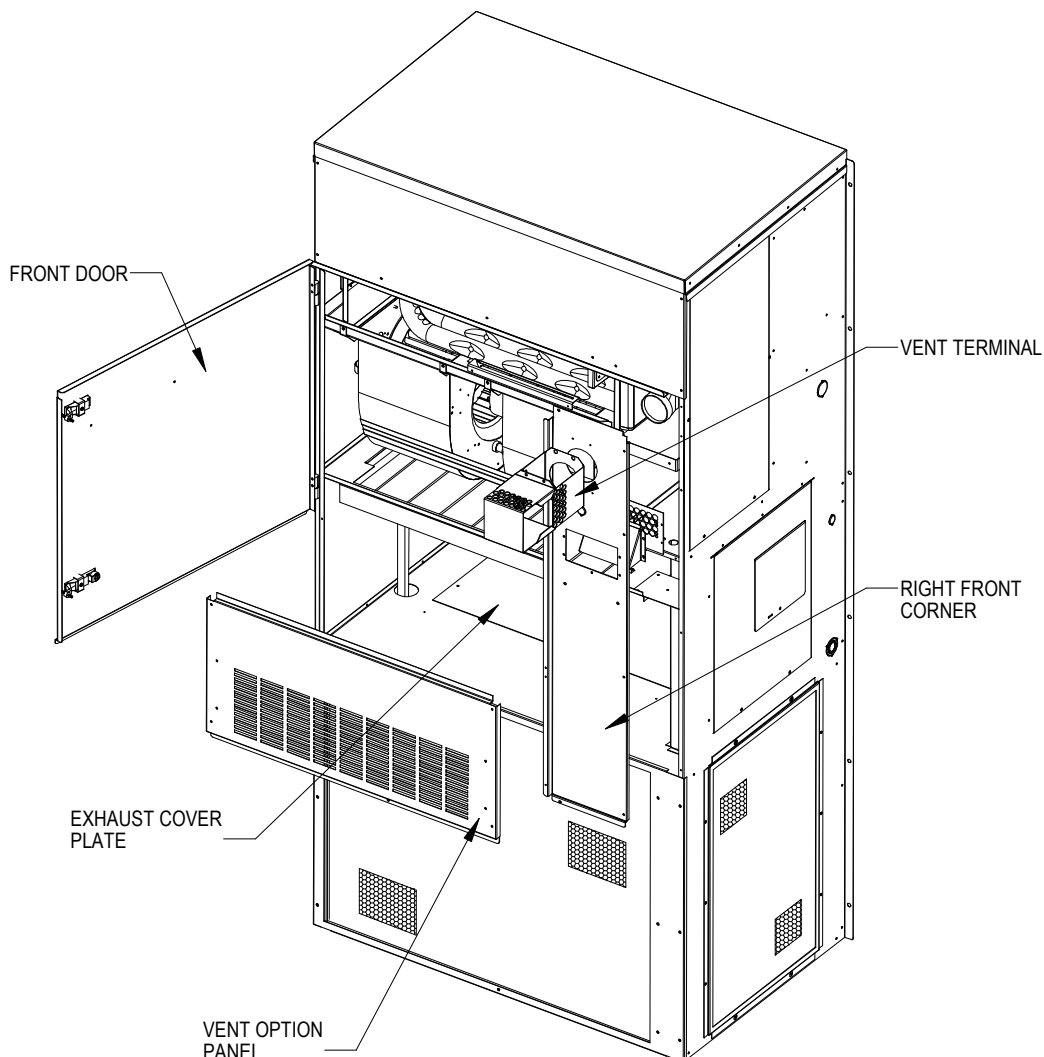

MIS-2416

**FIGURE 4**  
**Loose Piece Wire Harness Plug Install**

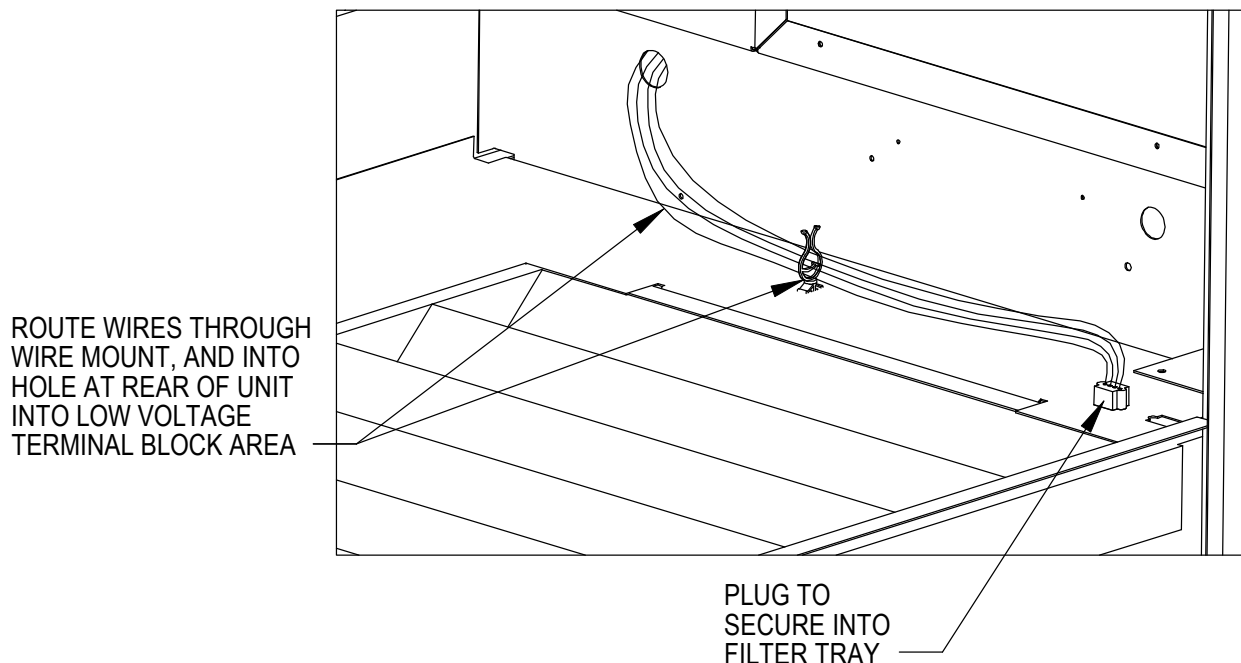

**MIS-2415**

7. Insert ventilator into the unit (see Figure 5 on page 8)

*IMPORTANT: Position front lip of ventilator on top of front grille and condenser partition (see Figure 5 Inset). This is important to ensure proper drainage of any water entering damper assembly.*

8. Open control panel to gain access to unit low voltage terminal block.
9. Route electrical harness leads through the 7/8" bushing in control panel (Figure 4) into low voltage control box.
10. Connect leads with fork terminal to corresponding points on terminal strip. (See wiring diagrams later in this manual or on ventilator.) Plug connector into corresponding hole in filter rack (see Figure 4).
11. Close control panel cover.
12. Plug mating connector from CRV into connector in filter rack (see Figure 5).

See page 9 to proceed to ventilator checkout procedure.

**FIGURE 5**  
**Ventilator Installed in Unit**

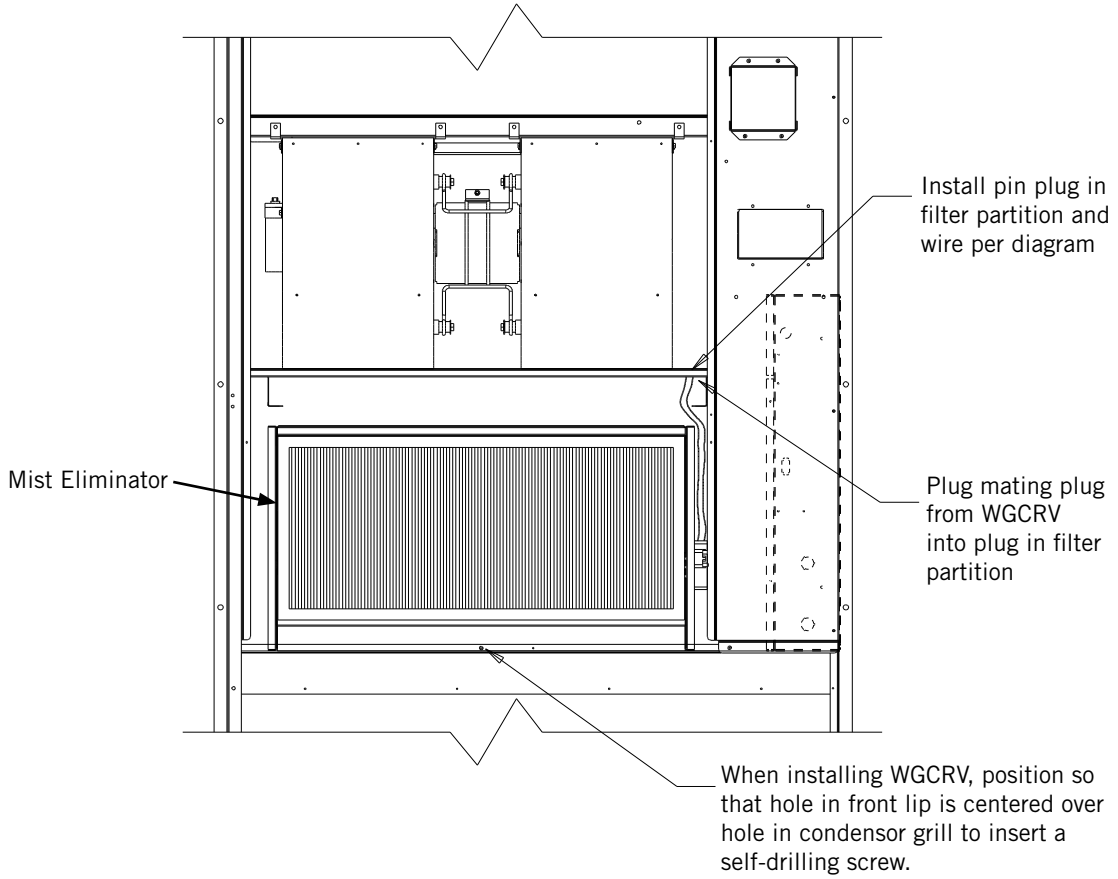

**FIGURE 5 INSET**

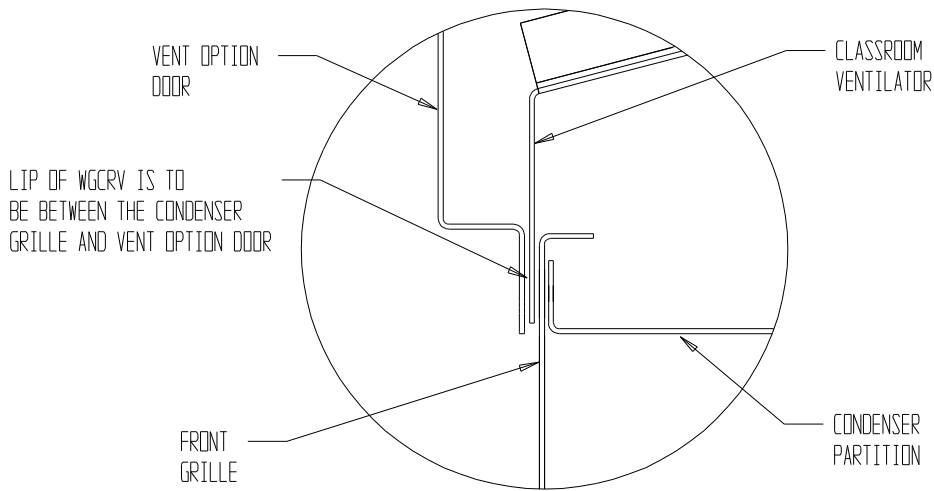

**MIS-1464A**



## Ventilator Checkout

### Blade Adjustment for Desired Ventilator Air

The amount of ventilation air supplied by the commercial room ventilator is dependent on four factors.

- a. Return air duct static pressure drop
- b. Supply air duct static pressure drop
- c. Indoor blower motor speed
- d. Damper blade open position setting

To determine the amount of fresh air that will be supplied to the structure, first determine the pressure drops of the supply and return air ducts. For free blow application with return air filter grille and supply grille, assume .05 supply static and .10 return static.

Determine on what speed the evaporator motor is running.

Refer to the tables found on the following pages to determine the blade setting necessary to achieve the ventilation air required at the supply and return static duct pressure drops that are applicable.

*NOTE: The ventilation air shown in the tables on the following pages is without the condenser fan running. When the condenser fan is running, the ventilation air will increase slightly.*

### WGCRVS Model Checkout

1. Remove mist eliminator to allow access to minimum position thumbwheel (see Figure 5).
2. Resupply power to unit.
3. Energize the evaporator blower by switching thermostat to the manual fan position with heat/cool in OFF position.
4. Ventilator should open to the position set by position adjustment thumbwheel. Cycle position adjustment thumbwheel to full open through full close. Observe damper blade operation throughout travel to assure free, unobstructed movement.
5. Adjust position adjustment thumbwheel until desired blade setting is reached with power applied to unit. See the tables found on the following pages for required blade setting versus ventilator air for the unit installed.
6. De-energize the evaporator blower. Damper blade should close.

### WGCRVP Model Checkout

1. Locate blade stop and adjust to setting that will allow the desired airflow from table for the unit installed (see Figure 6).
2. Resupply power to unit.
3. Energize the evaporation blower by switching thermostat to the manual fan position with heat/cool in OFF position.
4. Ventilation blade should open until it contacts the blade stop.
5. De-energize evaporator blower. Damper blade should close.

**FIGURE 6**  
**Locating Blade Stop**

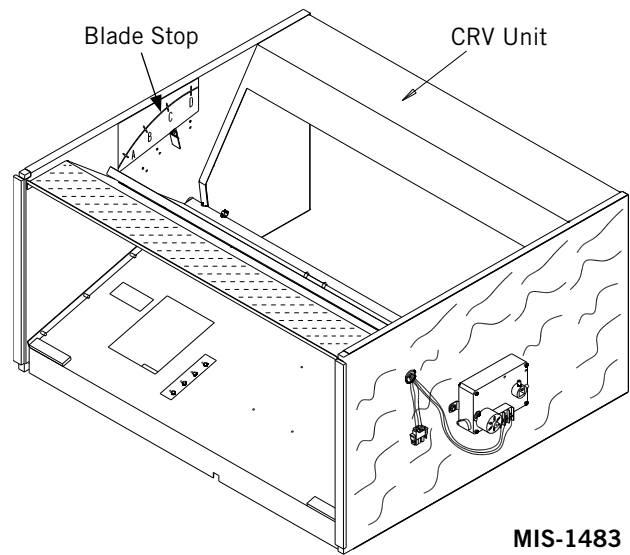

**MIS-1483**

**W24G CRV Airflow Versus Position - Low Speed**

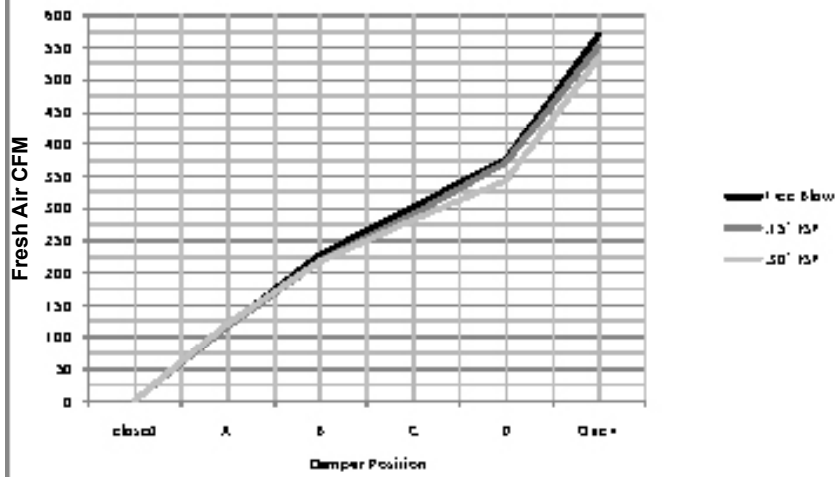

**W24G CRV Airflow Versus Position - Medium Speed**

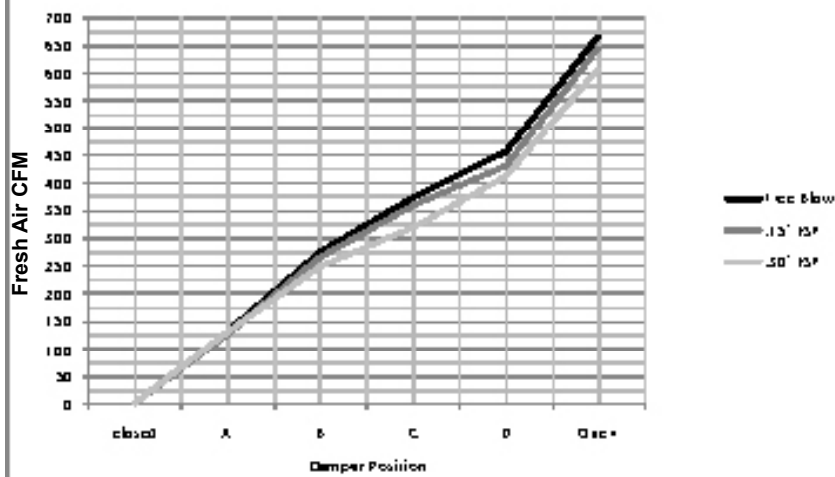

**W24G CRV Airflow Versus Position - High Speed**

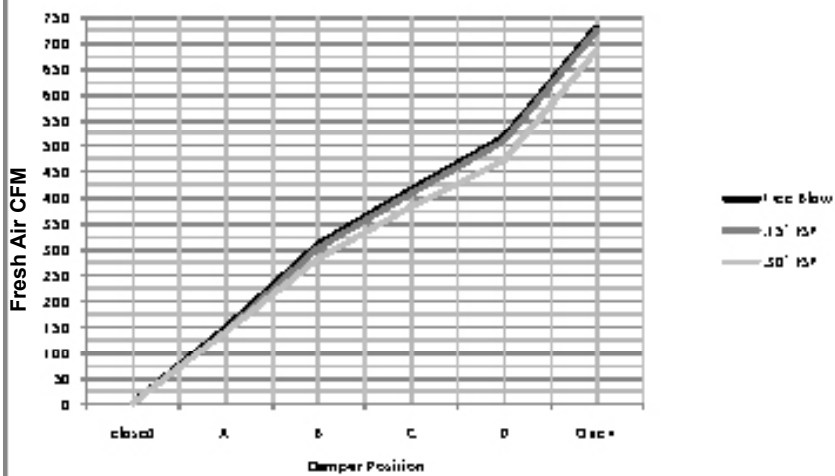

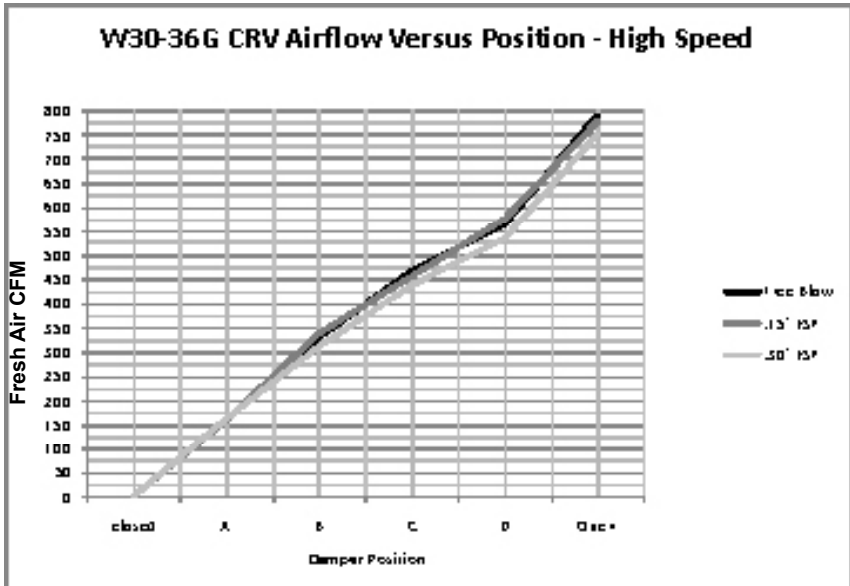
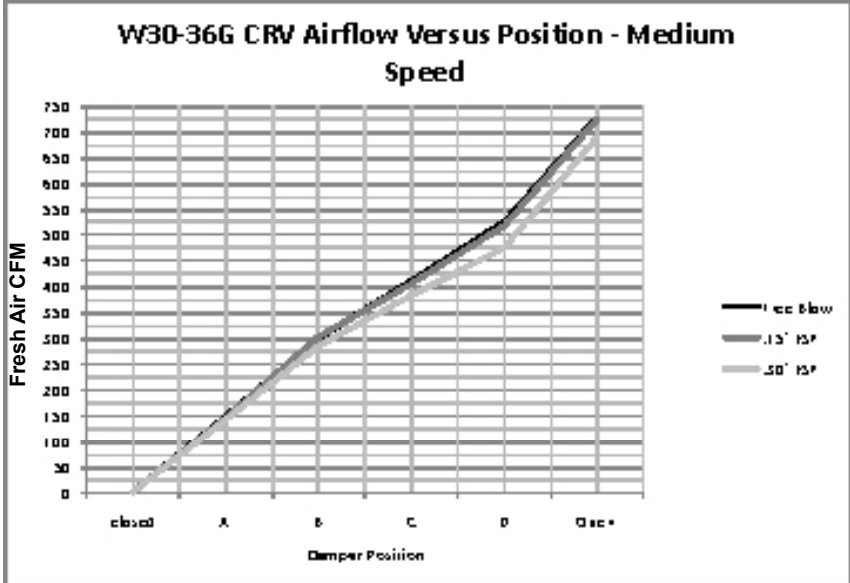
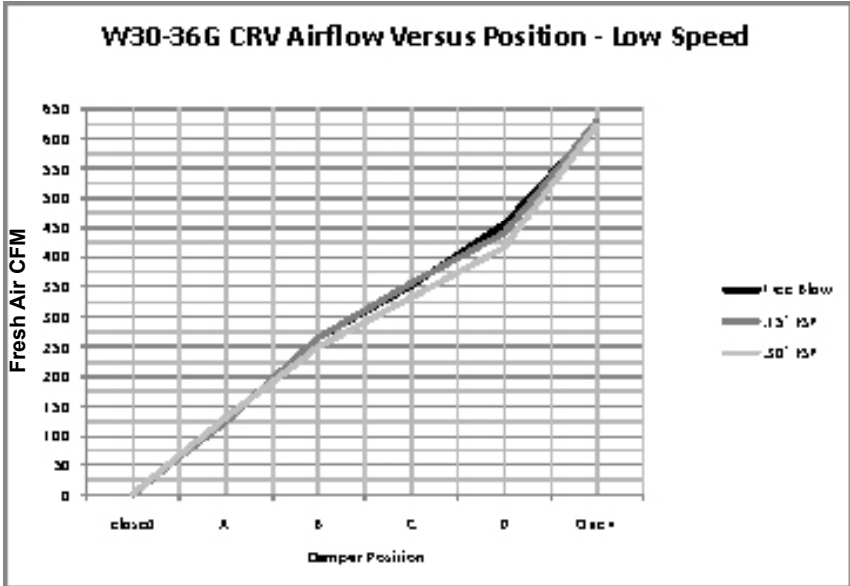

**W42-60G CRV Airflow Versus Position - Low Speed**

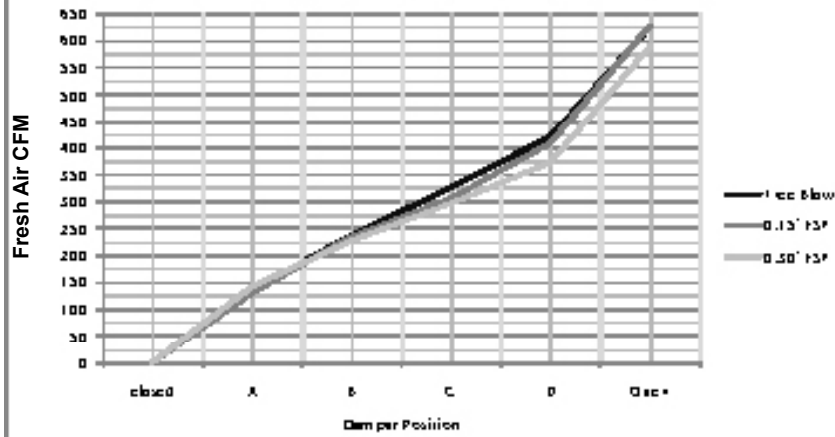

**W42-60G CRV Airflow Versus Position - Medium Speed**

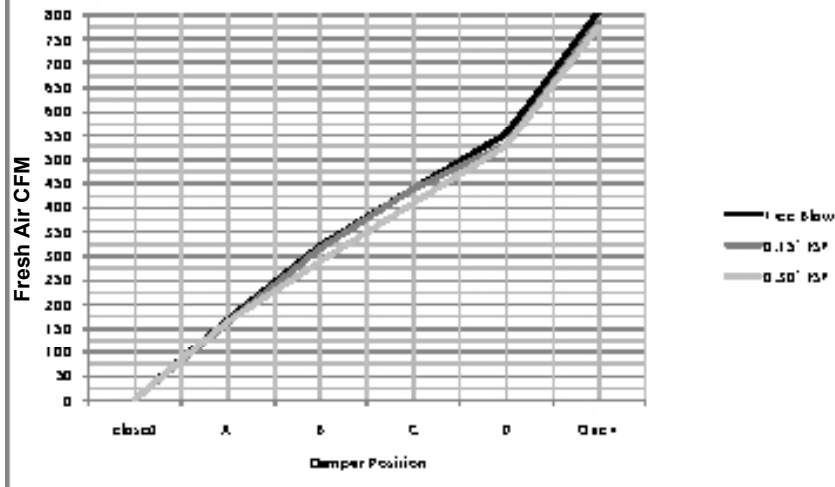

**W42-60G CRV Airflow Versus Position - High Speed**

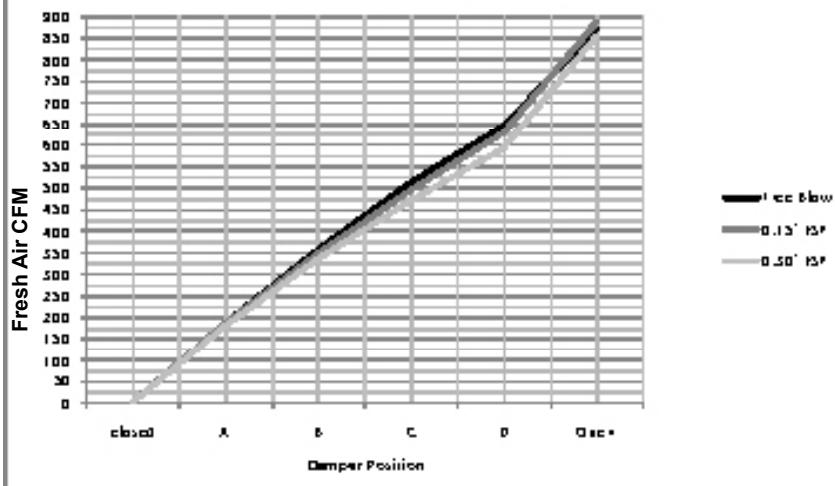

**FIGURE 7**  
**Thermostat Wiring Diagram**

Low Voltage Wiring - MOTORIZED FRESH AIR DAMPER,  
COMMERCIAL ROOM VENTILATOR-SPRING,  
COMMERCIAL ROOM VENTILATOR-POWER

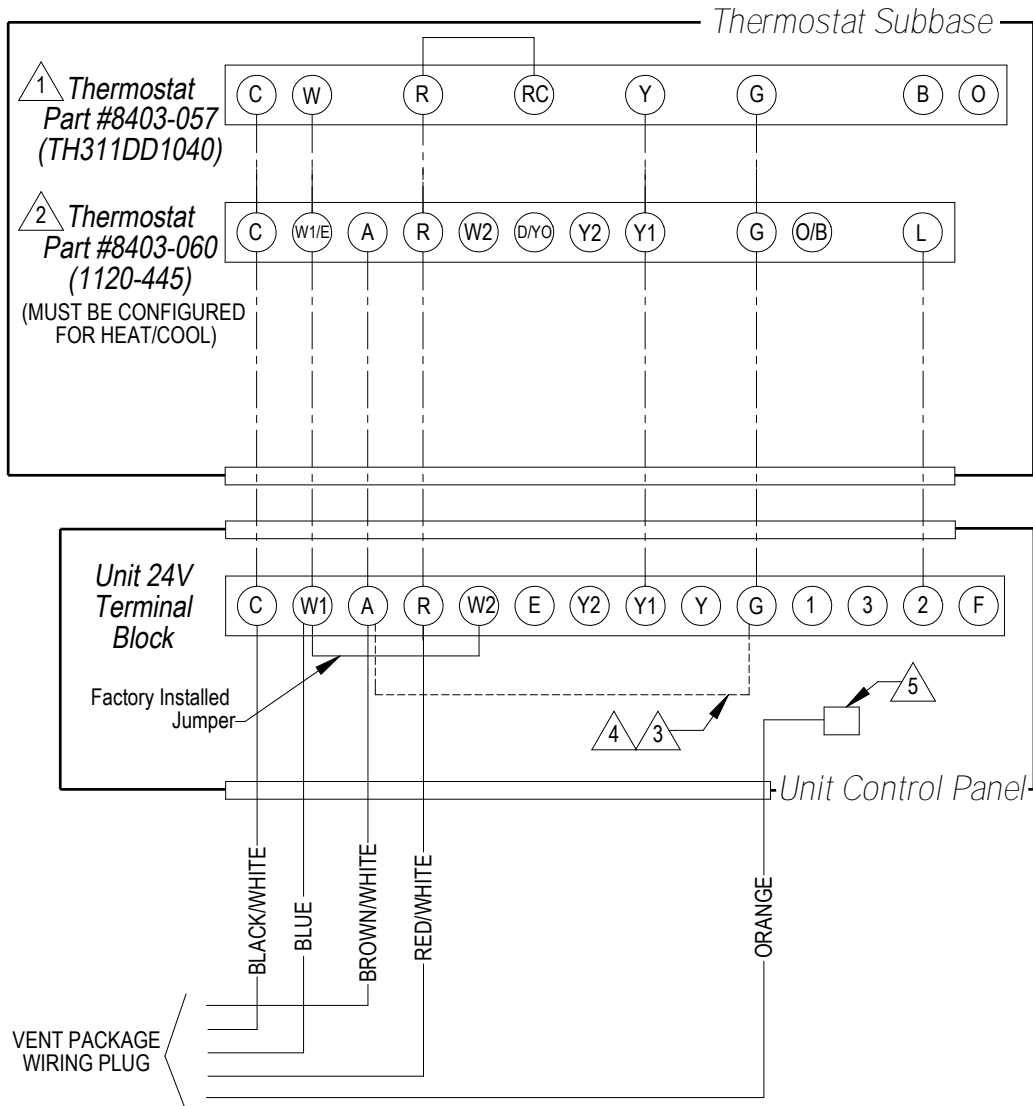

- 1 SET SWITCH ON THERMOSTAT TO "GAS-OIL"
- 2 CONFIGURE THERMOSTAT FOR HEAT/COOL
- 3 MUST INSTALL JUMPER FOR 8403-057 OR OTHER THERMOSTAT THAT DOES NOT HAVE OCCUPANCY OUTPUT.
- 4 INSTALL IF YOU REQUIRE VENTILATION ANYTIME BLOWER IS ON.
- 5 CONNECT ORANGE WIRE TO "G" TERMINAL IF OCCUPANCY-BASED THERMOSTAT OR CO2 CONTROLLER FOR DEMAND VENTILATION CONTROL IS APPLIED.

MIS-2775 A

**MIS-2775A**

**FIGURE 8  
Gas Electric Connection Diagram**

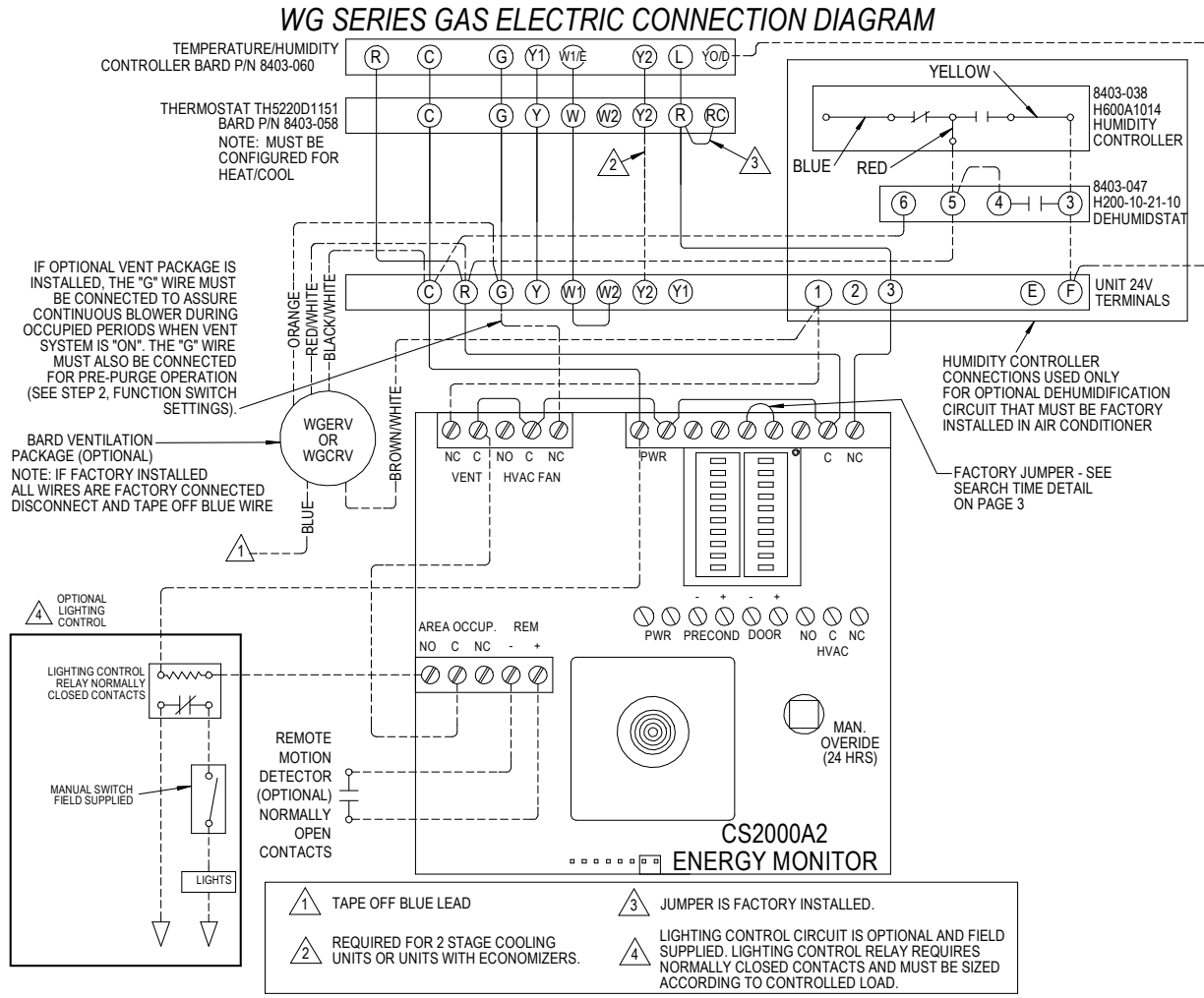

**RECOMMENDED SWITCH SETTINGS SHOWN BELOW**

FUNCTION SWITCHES		TEMPERATURE SWITCHES	
LEARN			90
PRE P			84
MODE			81
RATE			78
SEARCH-TIME			68
N/C			65
STAGE			62
AUX			58
DEMAND 2			54
DEMAND 1			48

4093-145F

**FIGURE 9**  
**CRVP Wiring Diagram**

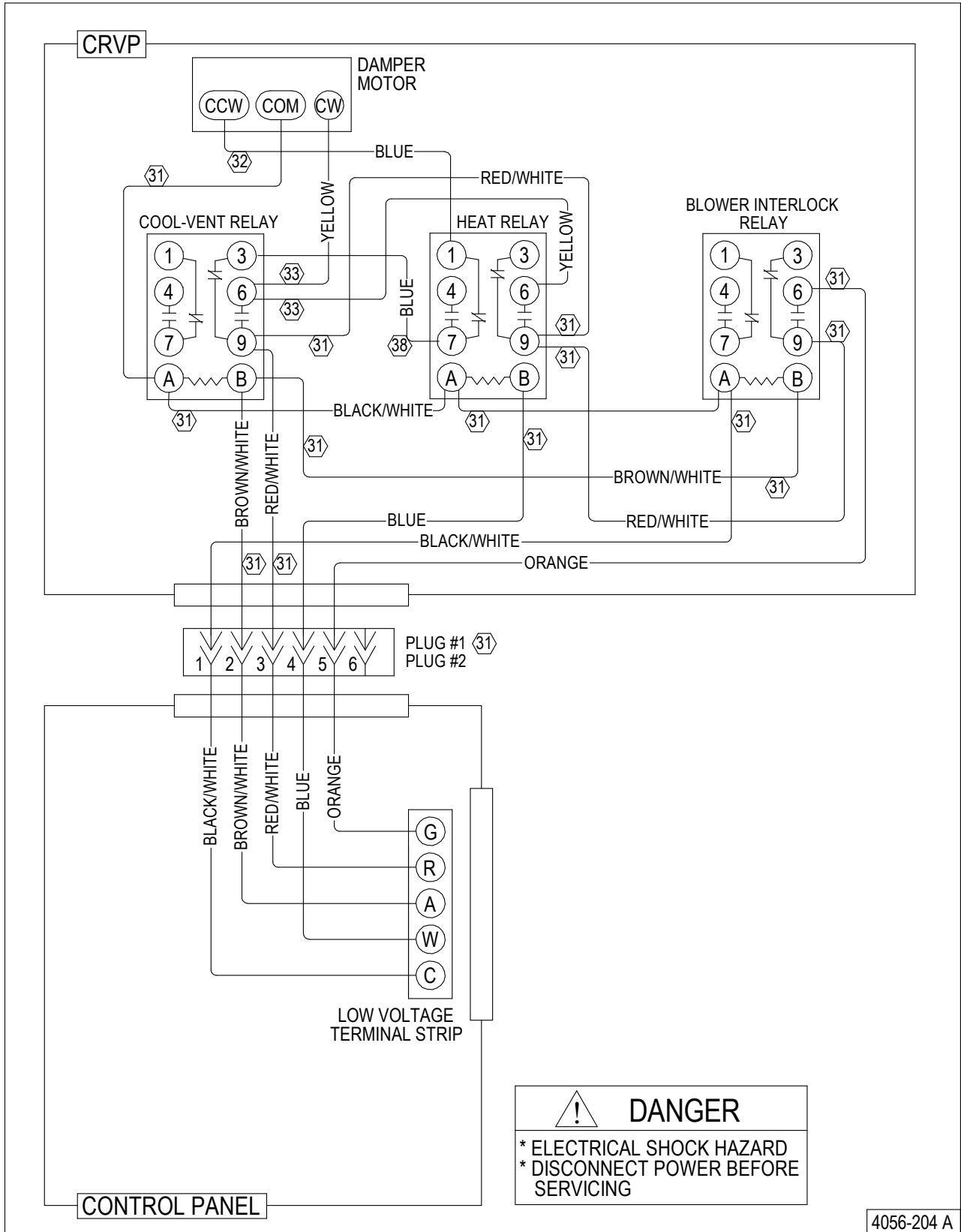

**⚠ DANGER**  
\* ELECTRICAL SHOCK HAZARD  
\* DISCONNECT POWER BEFORE SERVICING

4056-204 A

**FIGURE 10**  
**CRVS Wiring Diagram**

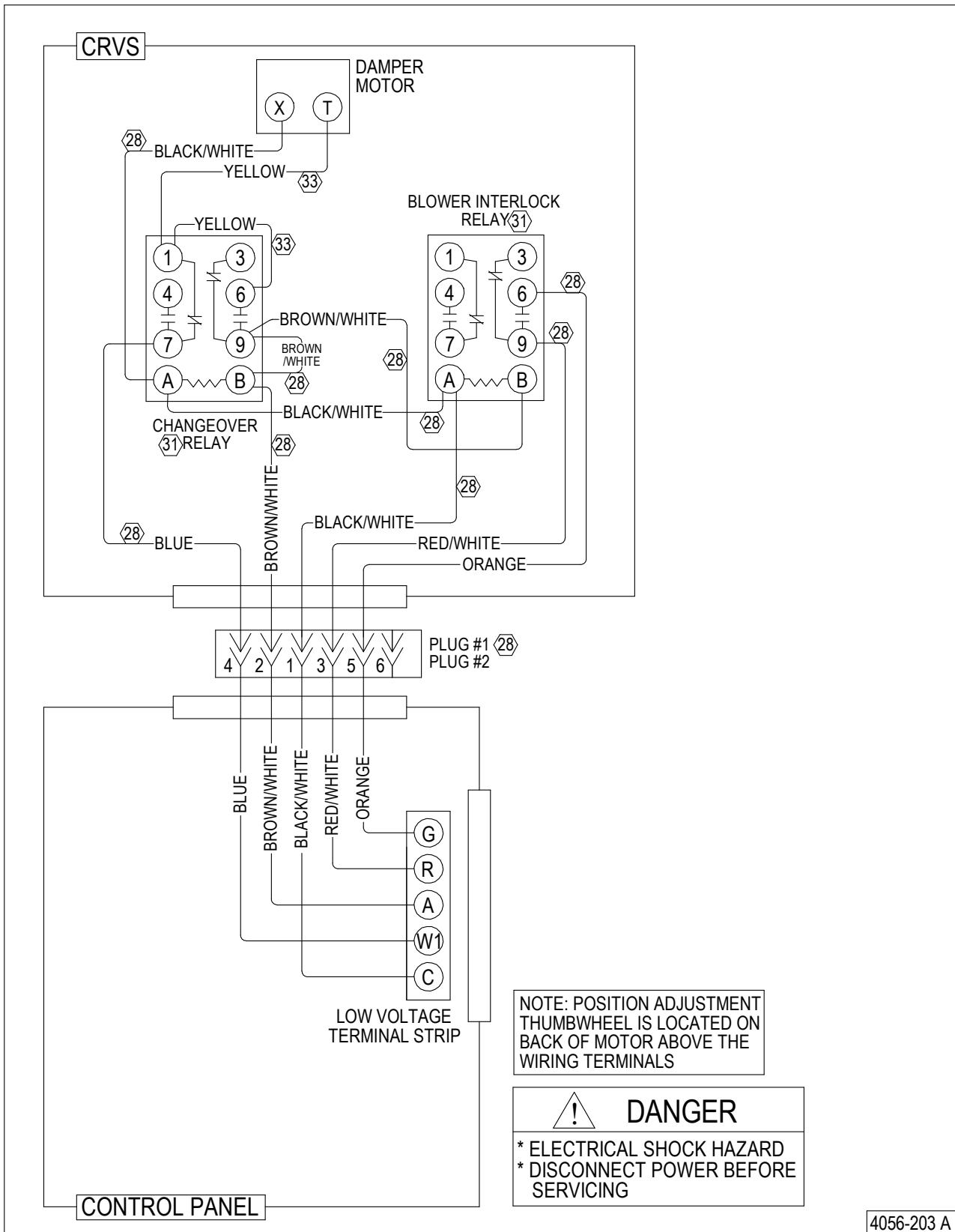

4056-203 A