INSTALLATION INSTRUCTIONS

COMMERCIAL ROOM VENTILATORS WITH EXHAUST

MODELS

WGCRVS-3A

WGCRVP-3A

WGCRVS-5A

WGCRVP-5A



Bard Manufacturing Company, Inc.
Bryan, Ohio 43506

Since 1914...Moving ahead just as planned

Manual : 2100-524
Supersedes: **NEW**
File: Volume III Tab 19
Date: 02-24-10

CONTENTS

WG General Information

General Information	3
Unpacking	3
Description	3
Features	3
Sequence of Operation	3

Installation Instructions

Basic Installation	6 & 9
Wiring Diagrams	15-16

Figures

Figure 1 Call for Blower Operation w/o Vent.	4
Figure 2 Call for Ventilation	5
Figure 3 Removal of Vent Option Panel	6
Figure 4 Install Loose Piece Wire Harness Plug...	7
Figure 5 Installation of CRV Plate	7
Figure 6 Installation of Ventilator	8
Figure 7 Thermostat Diagram	13
Figure 8 Gas Electric Connection	14

Charts

W24G - W60G CRV Airflow (Low, Medium, High)	10-12
--	-------

Manufactured under U.S. patent number
5,485,878

GENERAL

GENERAL INFORMATION

The ventilator should only be installed by a trained heating and air conditioning technician. These instructions serve as a guide to the technician installing the ventilator package. They are not intended as a step by step procedure with which the mechanically incline owner can install the package.

The ventilator housing is shipped in one carton which contains the electrical harness, miscellaneous hardware and installation instructions.

UNPACKING

Upon receipt of the equipment, be sure to compare the model number found on the shipping label with the accessory identification information on the ordering and shipping document to verify that the correct accessory has been shipped.

Inspect the carton housing of each ventilator as it is received, and before signing the freight bill verify that all items have been received and that there is no visible damage. Note any shortages or damage on all copies of the freight bill. The receiving party must contact the last carrier immediately, preferably in writing, requesting inspection by the carrier's agent. Concealed damage not discovered until after loading must be reported to the carrier within 15 days of its receipt.

DESCRIPTION

The ventilators are designed to be used with Bard 2 ton through 5 ton wall mount gas electric units. They are electromechanical vent systems designed to provide fresh air to meet indoor air quality standards with built in exhaust provisions.

COMMERCIAL ROOM VENTILATOR

FEATURES:

- One piece construction – easy to install with no mechanical linkage adjustment required.
- Exhaust air damper – built in with positive closed position. Provides exhaust air capability to prevent pressurization of tight buildings.
- **CRVS Model** Actuator motor – 24 volt, power open, spring return with built in torque limiting switch.
- **CRVP Model** Actuator motor – 24 volt, power open, power close with built in torque limiting switch.
- Provides up to 75 percent of outside air.

COMMERCIAL ROOM VENTILATOR SEQUENCE OF OPERATION

When no ventilation call is present, ventilation damper remains closed, and conditioned air is 100% return air. See Figure 1.

On a call for ventilation, CRV opens to full open position as set by minimum position potentiometer and energizes comfort air blower. See Figure 2.

**FIGURE 1
CALL FOR BLOWER OPERATION
WITHOUT VENTILATION**

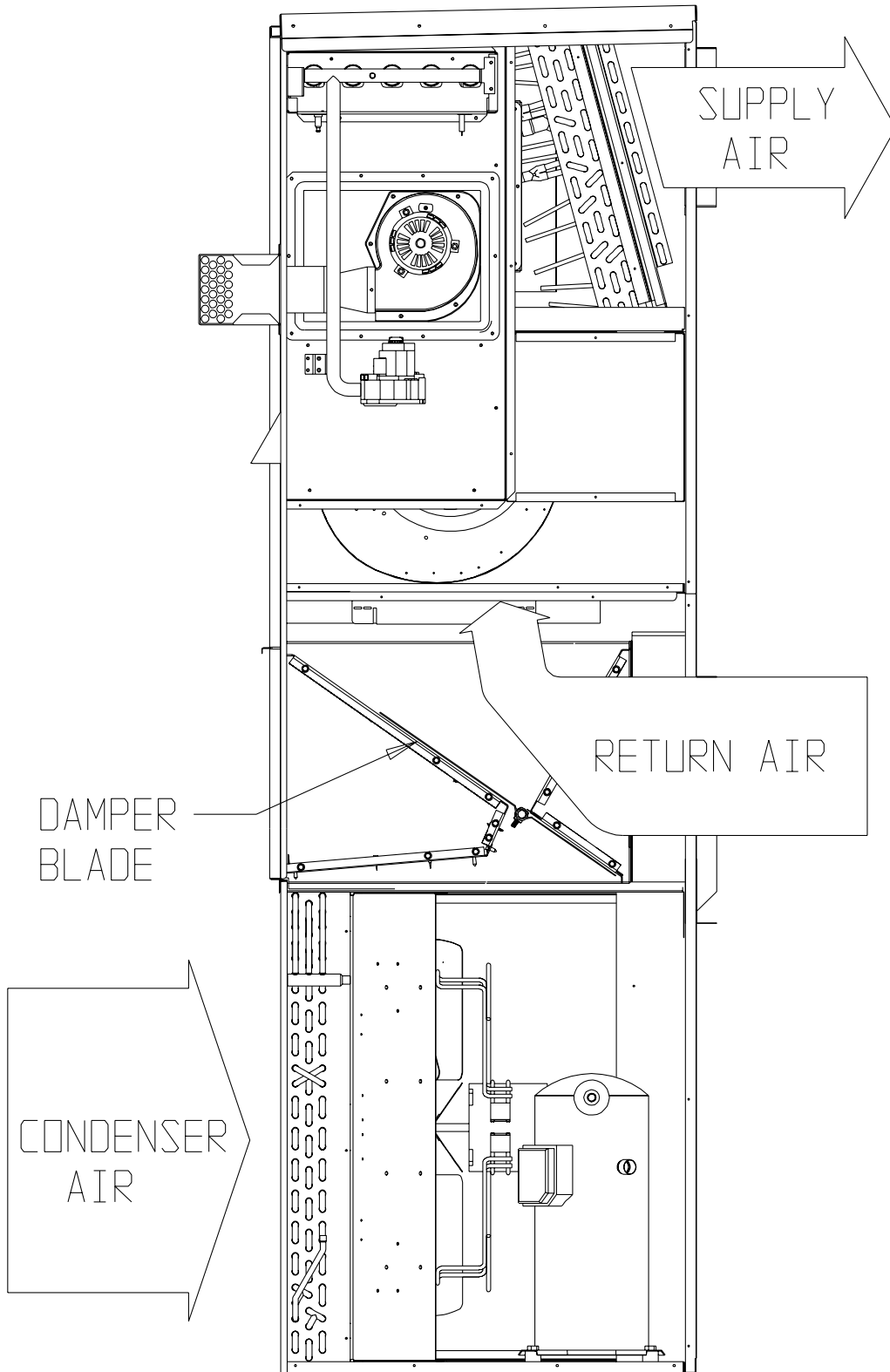

MIS-2412

FIGURE 2
APPEL POUR LA VENTILATION

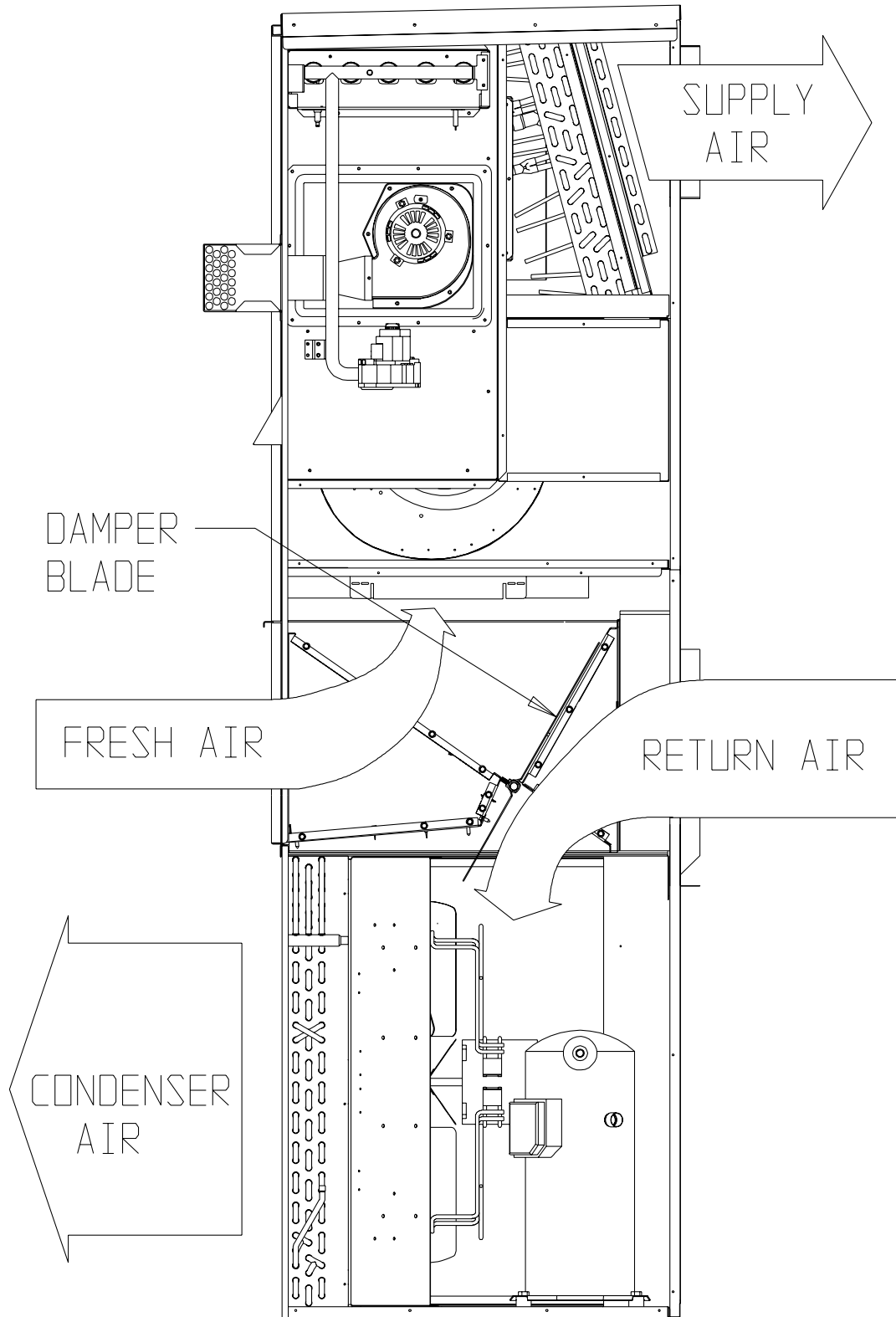

MIS-2413

INSTALLATION INSTRUCTIONS

BASIC INSTALLATION

1. Unpack the ventilator assembly which includes the integral ventilator with attached electrical harness and miscellaneous hardware.



WARNING

Open and lock unit disconnect switch before installing this accessory to prevent injury or death due to electrical shock or contact with moving parts. Turn thermostat to off.

2. Open the front door, and remove and save vent option panel on the Bard Wall mount units. (See Figure 3.)

3. Remove and save existing unit air filter and screw from front center grille. (See Figure 3.)
4. Remove and discard the exhaust cover plate. (See Figure 3.)
5. Locate loose piece wire harness shipped with CRV and install. (See Figure 4.)
6. Install ventilator by inserting the ventilator into the unit. (See Figure 6.)

IMPORTANT: Position front lip of ventilator on top of front grille and condenser partition. (See Figure 6 Inset.) This is important to ensure proper drainage of any water entering damper assembly.

7. Open control panel to gain access to unit low voltage terminal block.

FIGURE 3

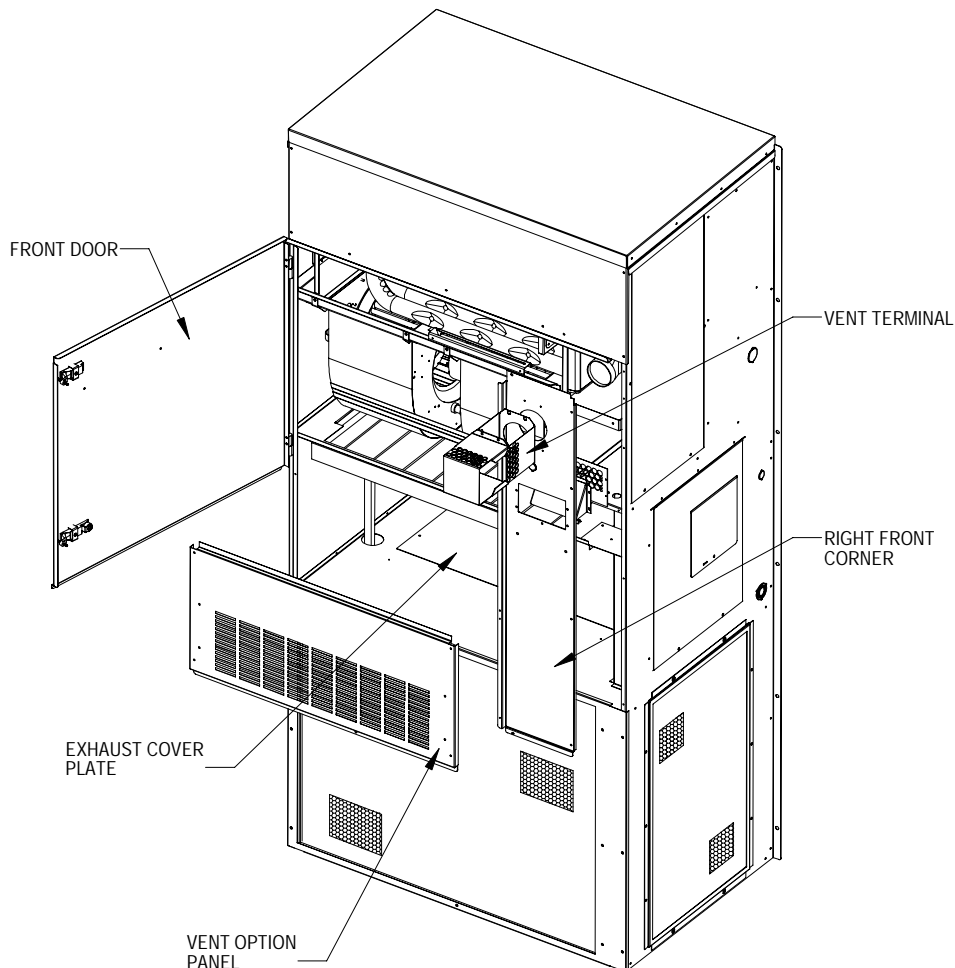

MIS-2416

**FIGURE 4
INSTALL LOOSE PIECE
WIRE HARNESS PLUG**

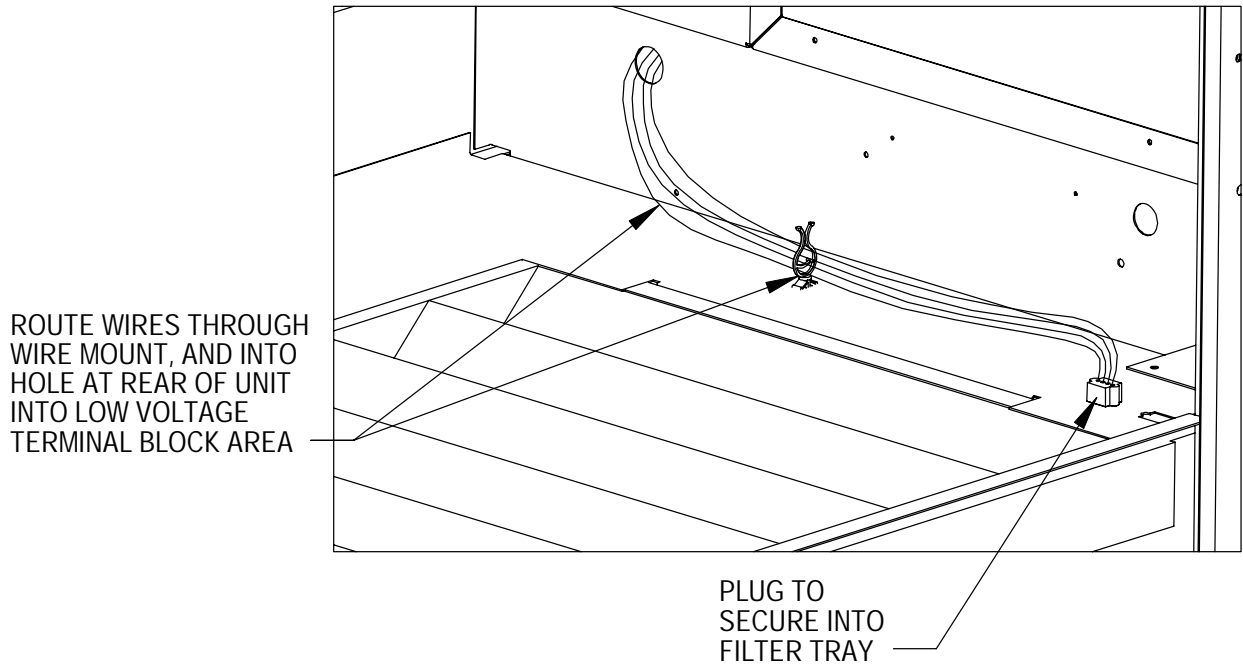

MIS-2415

FIGURE 5

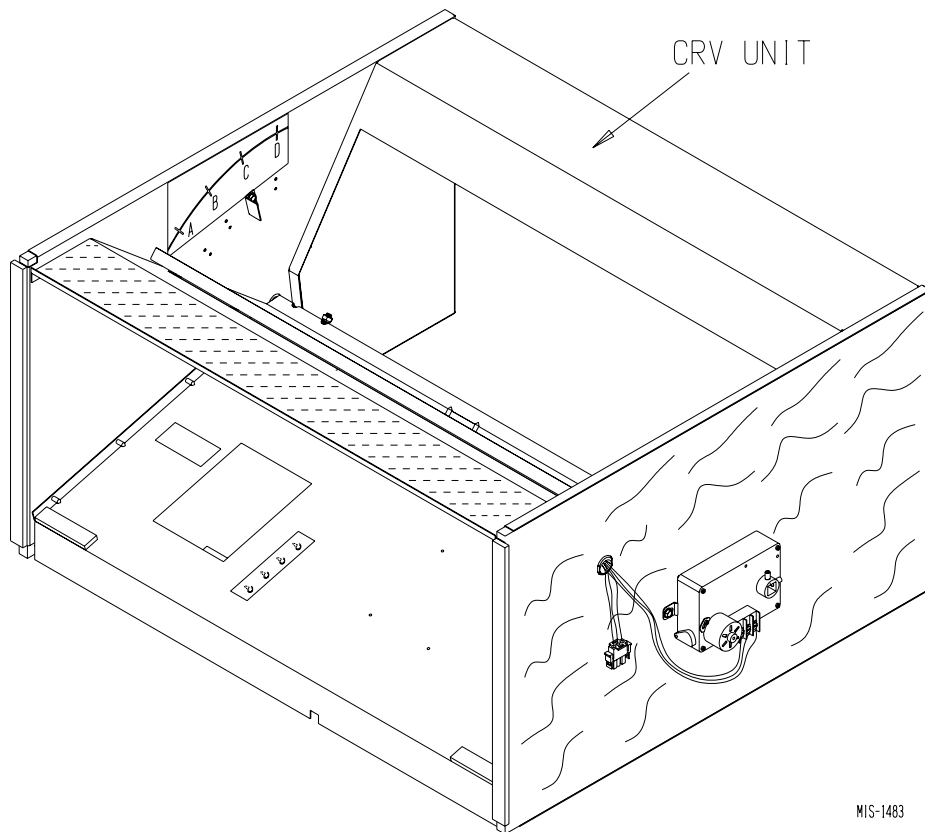

MIS-1483

FIGURE 6

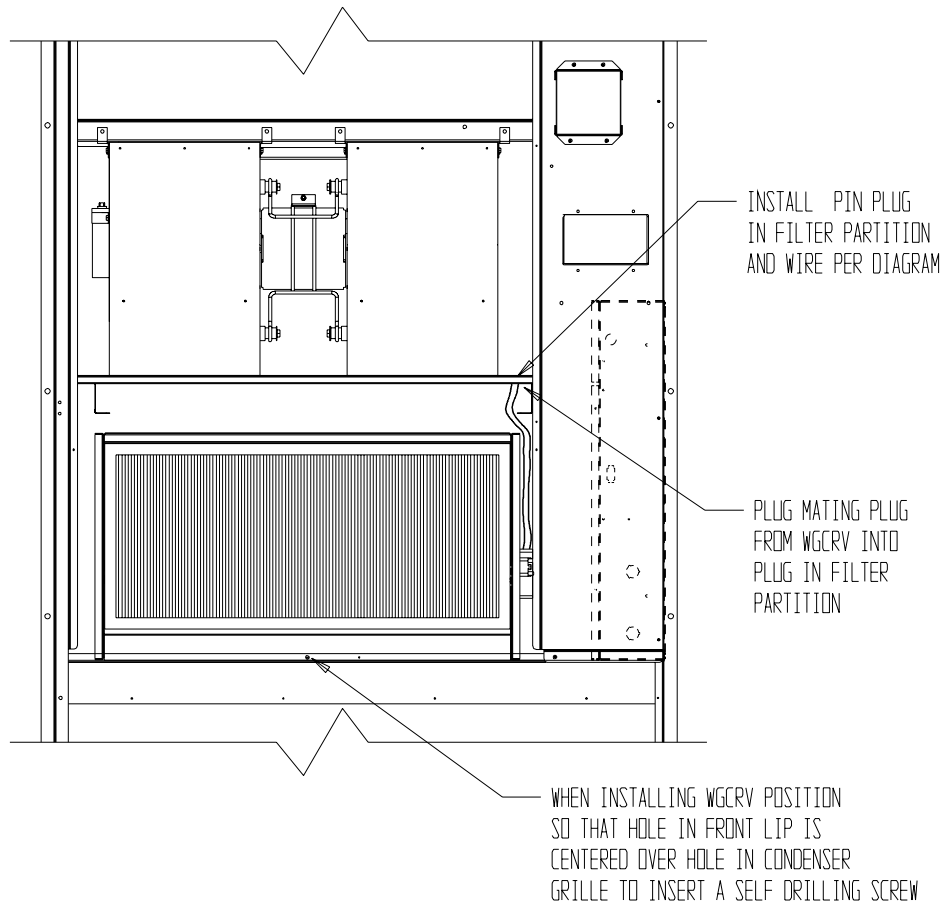
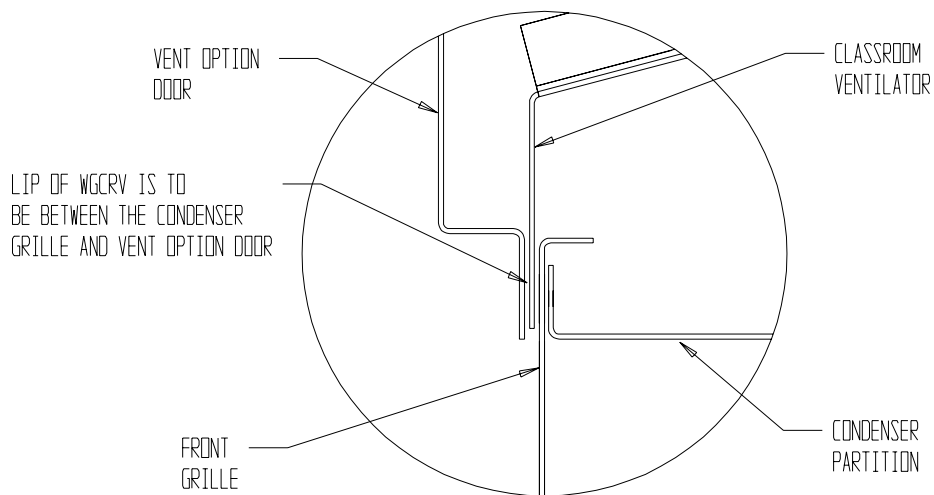

FIGURE 6 INSET



MIS-1464 A

8. Route electrical harness leads through the 7/8" bushing in control panel (Figure 4) into low voltage control box.
9. Connect leads with fork terminal to corresponding points on terminal strip. (See wiring diagrams later in this manual or on ventilator.) Plug connector into corresponding hole in filter rack. (See Figure 4.)
10. Close control panel cover.
11. Plug mating connector from CRV into connector in filter rack. (See Figure 4.)
12. Blade adjustment for desired ventilator air. The amount of ventilation air supplied by the commercial room ventilator is dependent on four (4) factors.
 - a. Return air duct static pressure drop.
 - b. Supply air duct static pressure drop.
 - c. Indoor blower motor speed.
 - d. Damper blade open position setting.

To determine the amount of fresh air that will be supplied to the structure, first determine the pressure drops of the supply and return air ducts. For free blow application with return air filter grille and supply grille, assume .05 supply static, .10 return static.

Determine on what speed the evaporator motor is running.

Refer to the tables on the following pages to determine the blade setting necessary to achieve the ventilation air required at the supply and return static duct pressure drops that are applicable.

NOTE: The ventilation air shown in the tables on the following pages is without the condenser fan running. When the condenser fan is running, the ventilation air will increase slightly.

13. Ventilator Checkout

CRVS Models (only)

- a. Remove mist eliminator to allow access to minimum position thumbwheel. (See Figure 6.)
- b. Resupply power to unit.
- c. Energize the evaporator blower by switching thermostat to the manual fan position with heat/cool in OFF position.
- d. Ventilator should open to the position set by position adjustment thumbwheel. Cycle position adjustment thumbwheel to full open through full close. Observe damper blade operation throughout travel to assure free, unobstructed movement.
- e. Adjust position adjustment thumbwheel until desired blade setting is reached with power applied to unit. See Tables for the unit installed for required blade setting versus ventilator air.
- f. De-energize the evaporator blower. Damper blade should close.
- g. This completes ventilator checkout for CRVS models.

CRVP Models (only)

- a. Locate blade stop and reposition to location that will allow the desired airflow from Table for the unit installed.
- b. Resupply power to unit.
- c. Energize the evaporation blower by switching thermostat to the manual fan position with heat/cool in OFF position.
- d. Ventilation blade should open until it contacts the blade stop.
- e. De-energize evaporator blower. Damper blade should close.
- f. This completes the ventilation checkout for CRVP models.

W24G CRV Airflow Versus Position - Low Speed

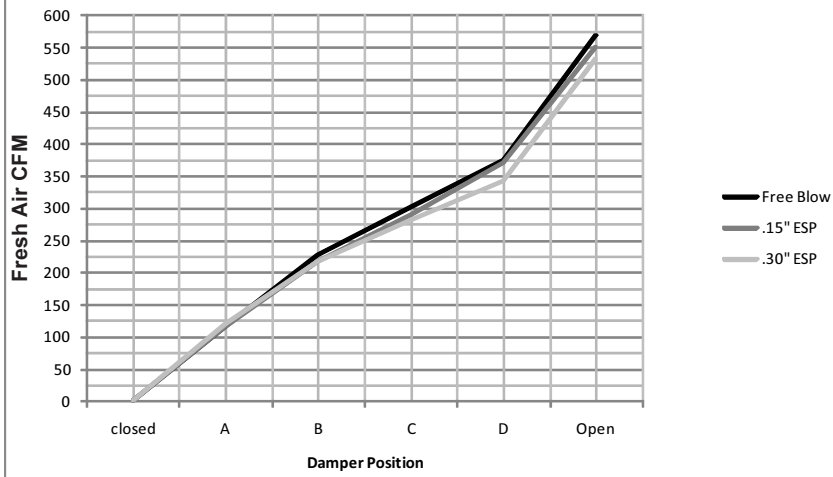

W24G CRV Airflow Versus Position - Medium Speed

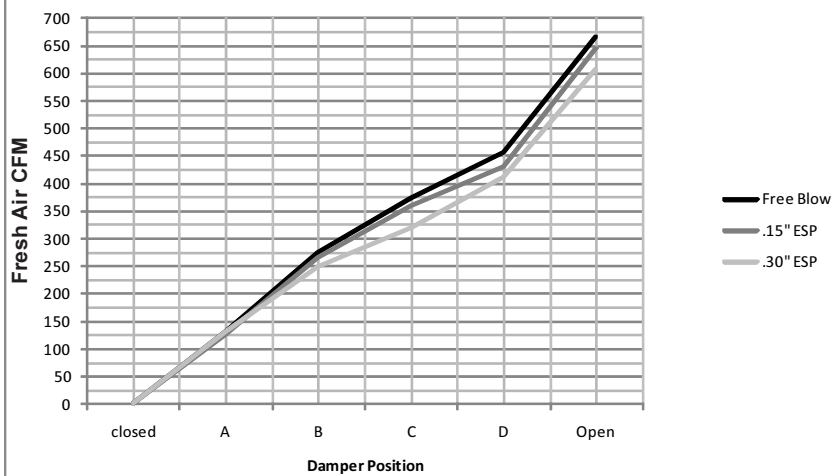

W24G CRV Airflow Versus Position - High Speed

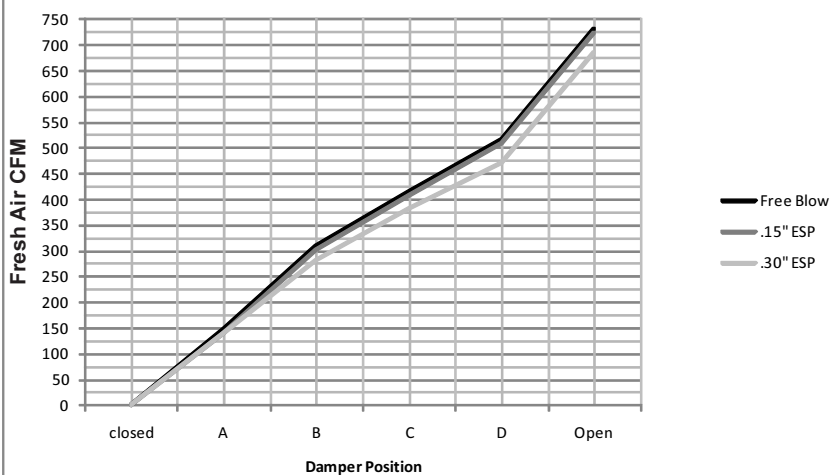

W30-36G CRV Airflow Versus Position - Low Speed

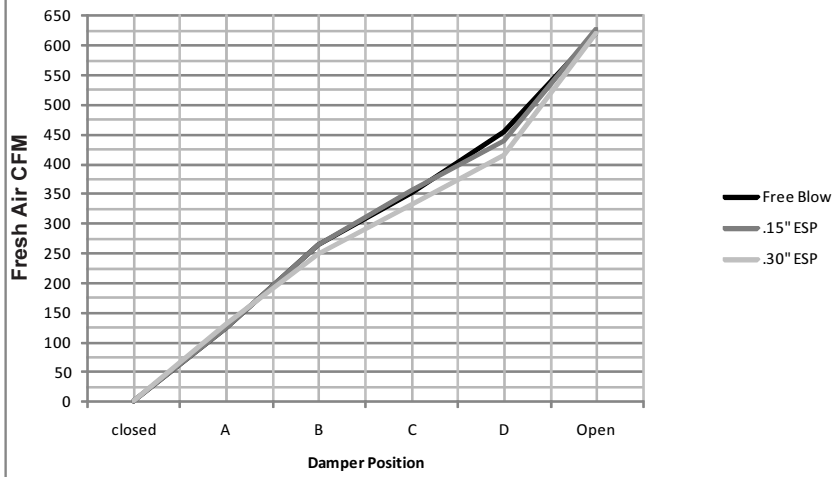

W30-36G CRV Airflow Versus Position - Medium Speed

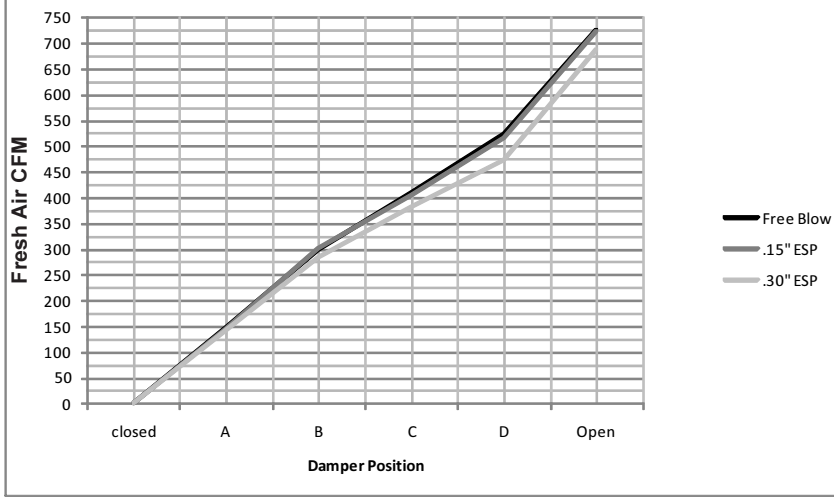

W30-36G CRV Airflow Versus Position - High Speed

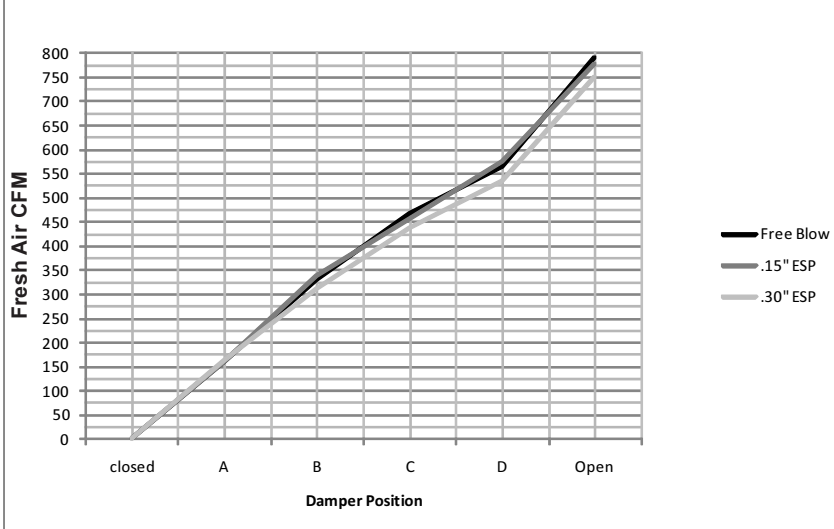

W42-60G CRV Airflow Versus Position - Low Speed

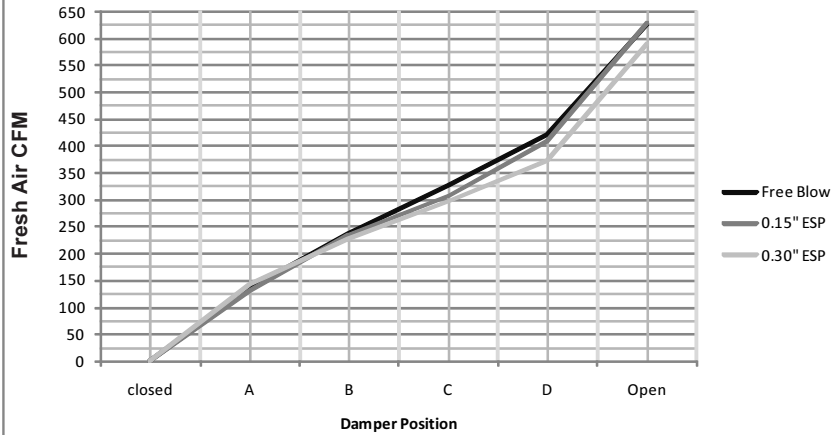

W42-60G CRV Airflow Versus Position - Medium Speed

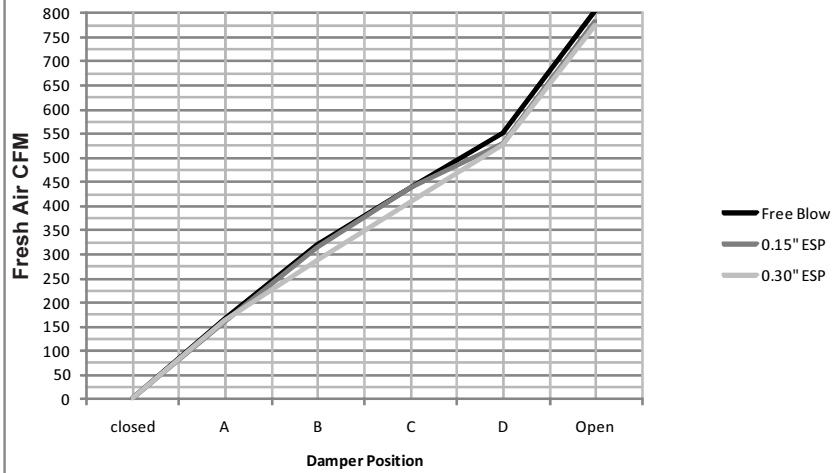

W42-60G CRV Airflow Versus Position - High Speed

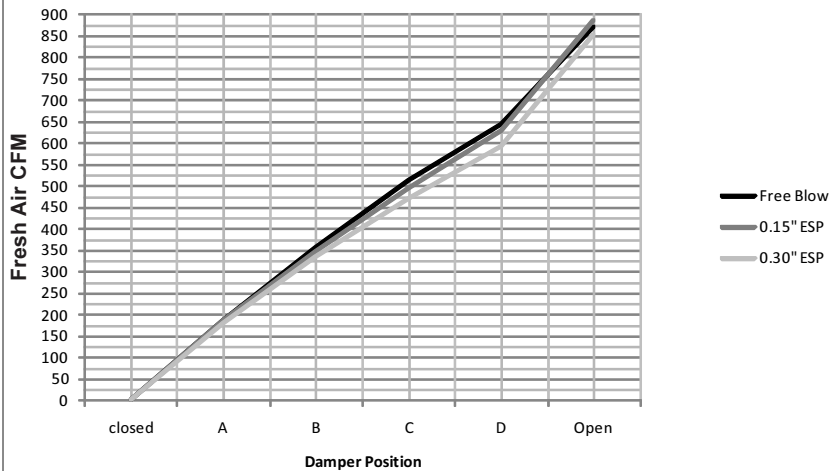

**FIGURE 7
THERMOSTAT WIRING DIAGRAM**

Low Voltage Wiring - MOTORIZED FRESH AIR DAMPER,
COMMERCIAL ROOM VENTILATOR-SPRING,
COMMERCIAL ROOM VENTILATOR-POWER

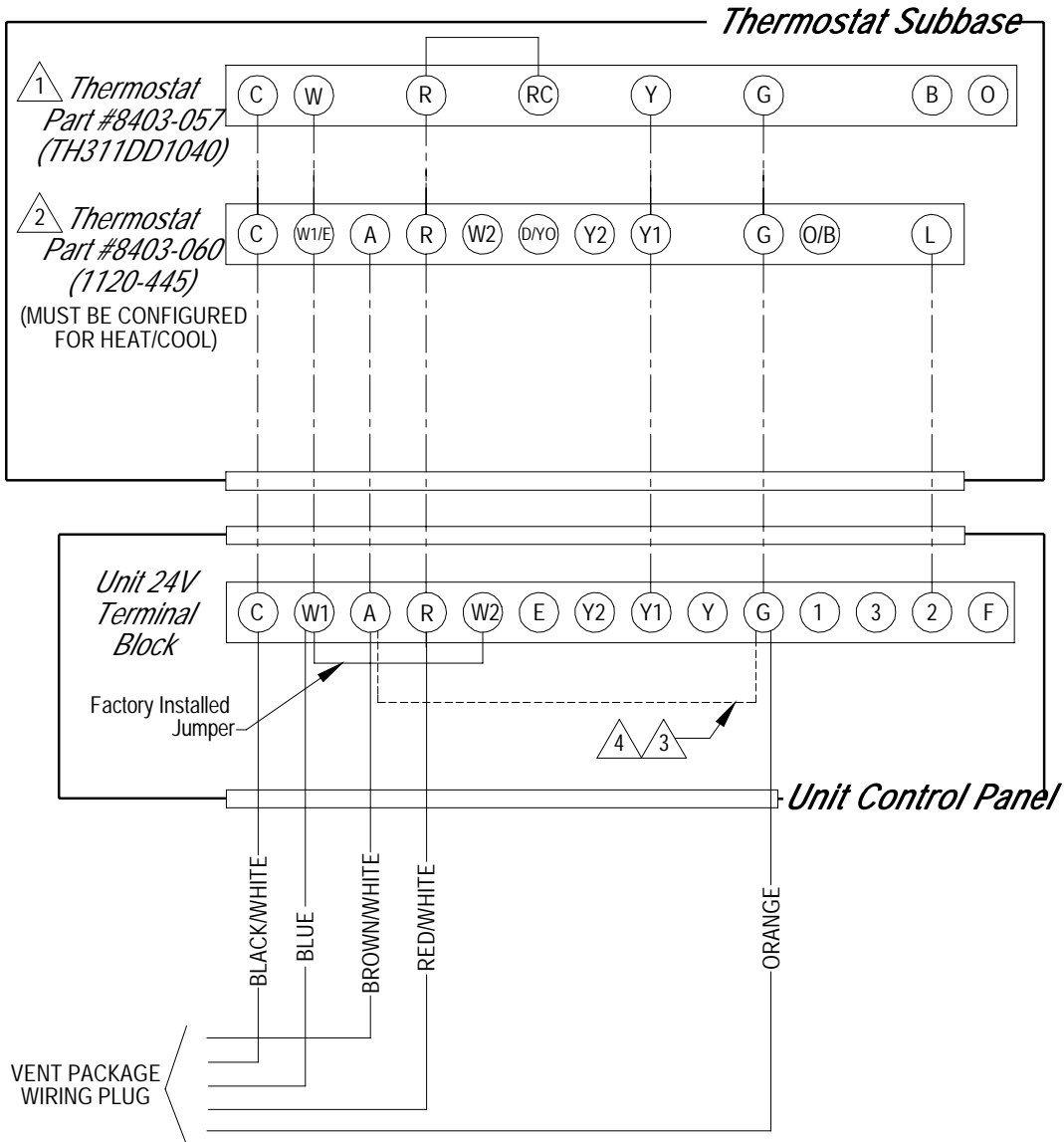

- 1 SET SWITCH ON THERMOSTAT TO "GAS-OIL"
- 2 CONFIGURE THERMOSTAT FOR HEAT/COOL
- 3 MUST INSTALL JUMPER FOR 8403-057 OR OTHER THERMOSTAT THAT DOES NOT HAVE OCCUPANCY OUTPUT.
- 4 INSTALL IF YOU REQUIRE VENTILATION ANYTIME BLOWER IS ON.

MIS-2775

**FIGURE 8
GAS ELECTRIC CONNECTION DIAGRAM**

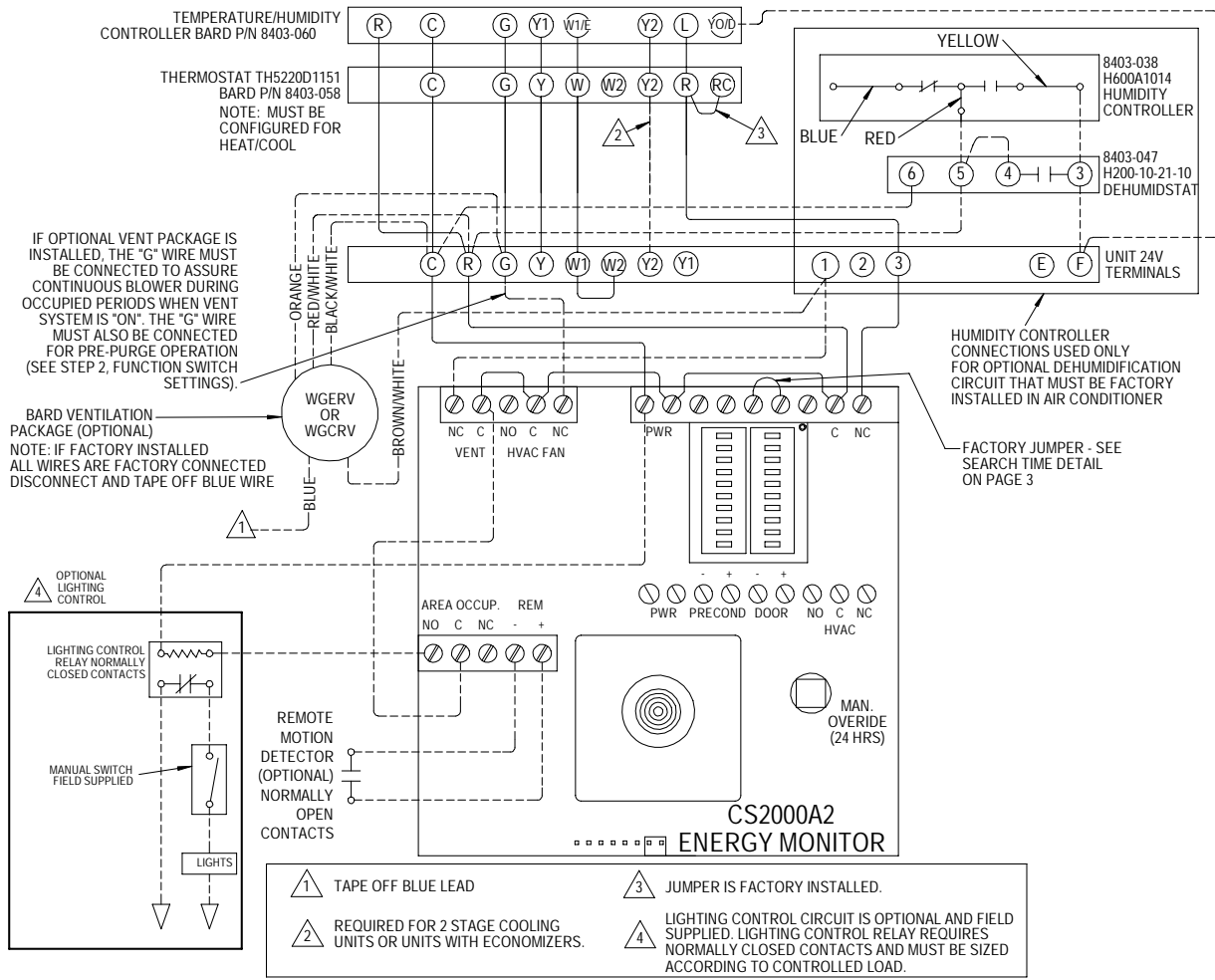

RECOMMENDED SWITCH SETTINGS SHOWN BELOW

FUNCTION SWITCHES		TEMPERATURE SWITCHES	
LEARN			90
PRE P			84
MODE			81
RATE			78
SEARCH-TIME			68
N/C			65
STAGE			62
AUX			58
DEMAND 2			54
DEMAND 1			48

