OPERATION INSTRUCTIONS

ENERGY RECOVERY VENTILATOR WITH EXHAUST

**Models: 920-0074 QWSERV
920-0138 QWSERV
with Intelligent Defrost**

**For Use With Bard
2 Through 5 Ton
QW*S Series**



Bard Manufacturing Company, Inc.
Bryan, Ohio 43506
Since 1914...Moving ahead, just as planned.

Manual: 2100-533C
Supersedes: 2100-533B
File: Volume II, Tab 14
Date: 08-29-12

CONTENTS

Electrical Specifications.....	3
General Description.....	3
920-0138 with Intelligent Defrost.....	3
Control Requirements.....	3
Recommended Control Sequences.....	4
Control Wiring.....	4
Ventilation Airflow	4
Performance & Application Data.....	5
Energy Recovery Ventilator Maintenance	6 & 7
Maintenance Procedures	7

Figures

Figure 1 Blower Speed Adjustment	4
Figure 2 Belt Replacement	8
Figure 3 Hub Assembly with Ball Bearings.....	9
Figure 4 Disconnect & Tape Off Wiring.....	12
Figure 5 Field Set CO ₂ Sensor Jumpers.....	12

Wiring Diagram

Wiring Diagram for 920-0074 QWSERV	10
Wiring Diagram for 920-0138 QWSERV w/l.D.	11

Tables

Table 1 Ventilation Air (CFM).....	4
Table 2 Summer Cooling Performance	5
Table 3 Winter Heating Performance	6

COPYRIGHT DECEMBER 2009
BARD MANUFACTURING COMPANY, INC.
BRYAN, OHIO USA 43506

ELECTRICAL SPECIFICATIONS

Model	Voltage	Amps	Control Voltage
920-0074	230 / 208	2.2	24V

Model	For Use with the Following Units
920-0074	QW2S-A, -B, -C QW3S-A, -B, -C QW4S-A, -B, -C QW5S-A, -B, -C

GENERAL DESCRIPTION

The Energy Recovery Ventilator was designed to provide energy efficient, cost effective ventilation to meet I. A. Q. (Indoor Air Quality) requirements while still maintaining good indoor comfort and humidity control for a variety of applications such as schools, classrooms, lounges, conference rooms, beauty salons and others. It provides a constant supply of fresh air for control of airborne pollutants including CO₂, smoke, radon, formaldehyde, excess moisture, virus and bacteria.

The ventilator incorporates patented rotary heat exchange state-of-the-art technology to remove both heat & moisture and provides required ventilation to meet the requirements of ASHRAE 62.1 standard.

It is designed as a single package which is factory installed. The package consists of a unique rotary Energy Recovery Cassette that can be easily removed for cleaning or maintenance. It has two 15-inch diameter heat transfer wheels for efficient heat transfer. The heat transfer wheels use a permanently bonded dry desiccant coating for total heat recovery.

Ventilation is accomplished with 2 blower/motor assemblies each consisting of a drive motor and dual blowers for maximum ventilation at low sound levels. Motor speeds can be adjusted so that air is exhausted at the same rate that fresh air is brought into the structure thus not pressuring the building. The rotating energy wheels provide the heat transfer effectively during both summer and winter conditions.

NOTE: Operation is not recommended below 5°F outdoor temperature because freezing of moisture in the heat transfer wheel can occur.

920-0138 WITH INTELLIGENT DEFROST

This model is equipped with a thermostat which is sensing the intake ventilation air. It is factory set to initiate a defrost sequence when operations are below 10°F. This defrost time is set for a 4-minute defrost for every 32 minutes of ERV operation. This control circuit controls the intake damper assembly allowing the ERV to operate with zero intake air to allow conditioned room air to defrost the cassette wheels.

CONTROL REQUIREMENTS

1. Indoor blower motor must be run whenever the ERV is run.
2. Select the correct motor speed on the ERV. Using Table 1 of the ERV Installation Instructions determine the motor speed needed to get the desired amount of ventilation air needed. For instance, do not use the high speed tap on a ERV if only 200 CFM of ventilation air is needed. Use the low speed tap. Using the high speed tap would serve no useful purpose and would effect the overall efficiency of the air conditioning system. System operation costs would also increase.
3. Run the ERV only during periods when the conditioned space is occupied. Running the ERV during unoccupied periods wastes energy, decreases the expected life of the ERV, and can result in a large moisture buildup in the structure. The ERV can remove up to 60 to 70% of the moisture in the incoming air, not 100% of it. Running the ERV when the structure is unoccupied allows moisture to build up in the structure because there is little or no cooling load. Thus, the air conditioner is not running enough to remove the excess moisture being brought in. Use a control system that in some way can control the system based on occupancy.

NOTE: The Energy Recovery Ventilator is NOT a dehumidifier.



IMPORTANT

Operating the ERV during unoccupied periods can result in a build up of moisture in the classroom.

RECOMMENDED CONTROL SEQUENCES

Several possible control scenarios are listed below:

1. Use a programmable electronic thermostat with auxiliary terminal to control the ERV based on daily programmed occupancy periods. Bard markets and recommends Bard Part No. 8403-060 programmable electronic thermostat for heat pump applications.
2. Use a motion sensor in conjunction with a mechanical thermostat to determine occupancy in the classroom. Bard markets the CS2000A for this use.
3. Use a DDC control system to control the ERV based on a room occupancy schedule.
4. Tie the operation of the ERV into the light switch. The lights in a room are usually on only when occupied.
5. Use a manual timer that the occupants turn to energize the ERV for a specific number of hours.
6. Use a programmable mechanical timer to energize the ERV and indoor blower during occupied periods of the day.
7. Use Bard Part No. 8403-056 CO₂ controller for “on-demand” ventilation.

CONTROL WIRING

The QWSERV comes wired in the low voltage control circuit from the factory.

With the “X” Remote Thermostat Option, it is default wired into the “A” terminal, which drives the vent to operate only during occupied periods when using a Bard 8403-060 thermostat or Bard CS2000 controller. If you prefer for the QWSERV to operate anytime the blower is operational, you will need to install a jumper wire from “G” to “A”. If you prefer to use Bard 8403-056 CO₂ controller to make the ventilation “on-demand”, there is a connection adjacent to the thermostat connections in the unit upper right-hand corner, and is marked to match CO₂ controller connections. Furthermore, disconnect and tape off the wire as shown in Figure 4 and you will need to field set the CO₂ sensor jumpers per Figure 5.

With the “D” Door Mounted Thermostat Option, the thermostat is already connected and programmed to operate the QWSERV only during occupied periods.

With the “H” Door Mounted Thermostat and CO₂ controller, the unit is ready to go with “on-demand” ventilation as controlled by the CO₂ controller.

VENTILATION AIRFLOW

The ERV is equipped with a 3-speed motor to provide the capability of adjusting the ventilation rates to the requirements of the specific application by simply changing motor speeds.

**TABLE 1
VENTILATION AIR (CFM)**

CFM	High Speed (Black)	Medium Speed (Blue)	Low Speed (Red)
	450	375	300

The ERV units are wired from the factory on medium intake and low exhaust speeds. The ERV is equipped with independently controlled 3-speed motor to provide the capability of adjusting the ventilation rates to the requirements of the specific application and to be able to provide positive pressure in the structure. This is accomplished by setting the intake blower on a higher speed than the exhaust blower.

WARNING

Open disconnect to shut all power OFF before doing this. Failure to do so could result in injury or death due to electrical shock.

Moving the speed taps located in the control panel can change the blower speed of the intake and exhaust. See Figure 1.

**FIGURE 1
BLOWER SPEED ADJUSTMENT**

- TO ADJUST INTAKE AND EXHAUST BLOWER SPEEDS
1. DISCONNECT POWER TO UNIT
 2. REMOVE ERV CONTROL PANEL COVER
 3. MOVE BLACK INSULATOR TO DESIRED SPEED ON TERMINAL CONNECTOR

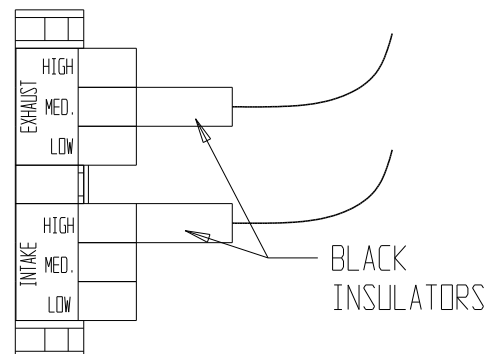

7961-651

MIS-2120

PERFORMANCE AND APPLICATION DATA

**TABLE 2
SUMMER COOLING PERFORMANCE
(INDOOR DESIGN CONDITIONS 75°DB/62°WB)**

Ambient O.D.		VENTILATION RATE 450 CFM 65% EFFICIENCY						VENTILATION RATE 375 CFM 66% EFFICIENCY						VENTILATION RATE 300 CFM 67% EFFICIENCY					
DB/WB	F	VLT	VLS	VLL	HRT	HRS	HRL	VLT	VLS	VLL	HRT	HRS	HRL	VLT	VLS	VLL	HRT	HRS	HRL
105	75	21465	14580	6884	13952	9477	4475	17887	12150	5737	11805	8018	3786	14310	9720	4590	9587	6512	3075
	70	14580	14580	0	9477	9477	0	12150	12150	0	8018	8018	0	9720	9720	0	6512	6512	0
	65	14580	14580	0	9477	9477	0	12150	12150	0	8018	8018	0	9720	9720	0	6512	6512	0
100	80	31590	12150	19440	20533	7897	12635	26325	10125	16200	17374	6682	10692	21060	8100	12960	14110	5427	8683
	75	21465	12150	9314	13952	7897	6054	17887	10125	7762	11805	6682	5123	14310	8100	6210	9587	5427	4160
	70	12352	12150	202	8029	7897	131	10293	10125	168	6793	6682	111	8235	8100	135	5517	5427	90
	65	12150	12150	0	7897	7897	0	10125	10125	0	6682	6682	0	8100	8100	0	5427	5427	0
	60	12150	12150	0	7897	7897	0	10125	10125	0	6682	6682	0	8100	8100	0	5427	5427	0
95	80	31590	9720	21870	20533	6318	14215	26325	8100	18225	17374	5345	12028	21060	6480	14580	14110	4341	9768
	75	21465	9720	11744	13952	6318	7634	17887	8100	9787	11805	5345	6459	14310	6480	7830	9587	4341	5246
	70	12352	9720	2632	8029	6318	1711	10293	8100	2193	6793	5345	1447	8235	6480	1755	5517	4341	1175
	65	9720	9720	0	6318	6318	0	8100	8100	0	5345	5345	0	6480	6480	0	4341	4341	0
	60	9720	9720	0	6318	6318	0	8100	8100	0	5345	5345	0	6480	6480	0	4341	4341	0
90	80	31590	7290	24300	20533	4738	15794	26325	6075	20250	17374	4009	13365	21060	4860	16200	14110	3256	10854
	75	21465	7290	14175	13952	4738	9213	17887	6075	11812	11805	4009	7796	14310	4860	9450	9587	3256	6331
	70	12352	7290	5062	8029	4738	3290	10293	6075	4218	6793	4009	2784	8235	4860	3375	5517	3256	2261
	65	7290	7290	0	4738	4738	0	6075	6075	0	4009	4009	0	4860	4860	0	3256	3256	0
	60	7290	7290	0	4738	4738	0	6075	6075	0	4009	4009	0	4860	4860	0	3256	3256	0
85	80	31590	4860	26730	20533	3159	17374	26325	4050	22275	17374	2672	14701	21060	3240	17820	14110	2170	11939
	75	21465	4860	16605	13952	3159	10793	17887	4050	13837	11805	2672	9132	14310	3240	11070	9587	2170	7416
	70	12352	4860	7492	8029	3159	4870	10293	4050	6243	6793	2672	4120	8235	3240	4995	5517	2170	3346
	65	4860	4860	0	3159	3159	0	4050	4050	0	2672	2672	0	3240	3240	0	2170	2170	0
	60	4860	4860	0	3159	3159	0	4050	4050	0	2672	2672	0	3240	3240	0	2170	2170	0
80	75	21465	2430	19035	13952	1579	12372	17887	2025	15862	11805	1336	10469	14310	1620	12690	9587	1085	8502
	70	12352	2430	9922	8029	1579	6449	10293	2025	8268	6793	1336	5457	8235	1620	6615	5517	1085	4432
	65	4252	2430	1822	2764	1579	1184	3543	2025	1518	2338	1336	1002	2835	1620	1215	1899	1085	814
	60	2430	2430	0	1579	1579	0	2025	2025	0	1336	1336	0	1620	1620	0	1085	1085	0
75	70	12352	0	12352	8029	0	8029	10293	0	10293	6793	0	6793	8235	0	8235	5517	0	5517
	65	4252	0	4252	2764	0	2764	3543	0	3543	2338	0	2338	2835	0	2835	1899	0	1899
	60	0	0	0	0	0	0	0	0	0	0	0	0	0	0	0	0	0	0

LEGEND

VLT = Ventilation Load – Total	HRT = Heat Recovery – Total
VLS = Ventilation Load – Sensible	HRS = Heat Recovery – Sensible
VLL = Ventilation Load – Latent	HRL = Heat Recovery – Latent

TABLE 3
WINTER HEATING PERFORMANCE — (INDOOR DESIGN CONDITIONS 70°F DB)

Ambient O.D.	VENTILATION RATE								
	450 CFM 80% EFFICIENCY			375 CFM 81% EFFICIENCY			300 CFM 82% EFFICIENCY		
DB/°F	VLT	HRS	VLS	VLT	HRS	VLS	VLT	HRS	VLS
65	2430	1944	486	2025	1640	385	1620	1328	292
60	4860	3888	972	4050	3280	770	3240	2656	583
55	7290	5832	1458	6075	4920	1154	4860	3985	875
50	9720	7776	1944	8100	6561	1539	6480	5313	1166
45	12150	9720	2430	10125	8201	1924	8100	6642	1458
40	14580	11664	2916	12150	9841	2309	9720	7970	1750
35	17010	13608	3402	14175	11481	2693	11340	9298	2041
30	19440	15552	3888	16200	13122	3078	12960	10627	2333
25	21870	17496	4374	18225	14762	3463	14580	11955	2624
20	24300	19440	4860	20250	16402	3848	16200	13284	2916
15	26730	21384	5346	22275	18042	4232	17820	14612	3208
10	29160	23328	5832	24300	19683	4617	19440	15941	3499
5	31590	25272	6318	26325	21323	5002	21060	17269	3791
0	34020	27216	6804	28350	22964	5387	22680	18598	4082
-5	36450	29160	7290	30375	24604	5771	24300	19926	4374
-10	38880	31104	7776	32400	26244	6156	25920	21254	4666

NOTE: Sensible performance only is shown for winter application.

LEGEND

VLT = Ventilation Load – Total

HRS = Heat Recovery – Sensible

VLS = Ventilation Load – Sensible

ENERGY RECOVERY VENTILATOR MAINTENANCE

GENERAL INFORMATION

The ability to clean exposed surfaces within air moving systems is an important design consideration for the maintenance of system performance and air quality. The need for periodic cleaning will be a function of operating schedule, climate, and contaminants in the indoor air being exhausted and in the outdoor air being supplied to the building. All components exposed to the airstream, including energy recovery wheels, may require cleaning in most applications.

Rotary counterflow heat exchangers (heat wheels) with laminar airflow are “self-cleaning” with respect to dry particles. Smaller particles pass through; larger particles land on the surface and are blow clear as the flow direction is reversed. For this reason the primary need for cleaning is to remove films of oil based aerosols that have condensed on energy transfer surfaces. Buildup of material over time may eventually reduce airflow. Most importantly, in the case of desiccant coated (enthalpy) wheels, such films can close off micron sized pores at the surface of the desiccant material, reducing the efficiency with which the desiccant can absorb and exude moisture.

FREQUENCY

In a reasonably clean indoor environment such as a school, office building, or home, experience shows that reductions of airflow or loss of sensible (temperature) effectiveness may not occur for ten or more years. However, experience also shows that measurable changes in latent energy (water vapor) transfer can occur in shorter periods of time in commercial, institutional and residential applications experiencing moderate occupant smoking or with cooking facilities. In applications experiencing unusually high levels of occupant smoking, such as smoking lounges, nightclubs, bars and restaurants, washing of energy transfer surfaces, as frequently as every six months, may be necessary to maintain latent transfer efficiency. Similar washing cycles may also be appropriate for industrial applications involving the ventilation of high levels of smoke or oil based aerosols such as those found in welding or machining operations, for example. In these applications, latent efficiency losses of as much as 40% or more may develop over a period of one to three years.

CLEANABILITY AND PERFORMANCE

In order to maintain energy recovery ventilation systems, energy transfer surfaces must be accessible for washing to remove oils, grease, tars and dirt that can impede performance or generate odors. Washing of the desiccant surfaces is required to remove contaminate buildups that can reduce adsorption of water molecules. The continued ability of an enthalpy wheel to transfer latent energy depends upon the permanence of the bond between the desiccant and the energy transfer surfaces.

Bard wheels feature silica gel desiccant permanently bonded to the heat exchange surface without adhesives; the desiccant will not be lost in the washing process. Proper cleaning of the Bard energy recovery wheel will restore latent effectiveness to near original performance.

MAINTENANCE PROCEDURES

NOTE: Local conditions can vary and affect the required time between routine maintenance procedures, therefore all sites (or specific units at a site) may not have the same schedule to maintain acceptable performance. The following timetables are recommended and can be altered based on local experience.

QUARTERLY MAINTENANCE

1. Inspect mist eliminator/prefilter and clean if necessary. This filter is located in the wall sleeve and can be accessed by either removing the exterior louver grille, the vent package from inside the unit, or by disconnecting the unit from the wall brackets, and rolling the unit away from the sleeve on its integral wheel system. The filter is an aluminum mesh filter and can be cleaned with water and any detergent not harmful to aluminum.
2. Inspect the comfort air filter and clean or replace as necessary. This filter is located behind the front-hinged service door.
3. Inspect energy recovery ventilator for proper wheel rotation and dirt buildup. This can be done in conjunction with Item 2 above. Energize the energy recovery ventilator after inspecting the filter and observe for proper rotation and/or dirt buildup.
4. Recommended energy recovery wheel cleaning procedures follow: Disconnect all power to the unit. Open the front-hinged service door to the unit.
5. Remove the front cassette retaining panel from the front of the ERV. Unplug the amp connectors to the cassette drive motor. Slide energy recovery cassette out of the ventilator.
6. Use a shop vacuum with brush attachment to clean both sides of the energy recovery wheels.
7. Reverse shop vacuum to use as a blower and blow out any residual dry debris from the wheel.

NOTE: Discoloration and staining of the wheel does not affect its performance. Only excessive buildup of foreign material needs to be removed.

8. If any belt chirping or squealing noise is present, apply a small amount of LPS-1 or equivalent dry film lubricant to the belt.

ANNUAL MAINTENANCE

1. Inspect and conduct the same procedures as outlined under Quarterly Maintenance.
2. To maintain peak latent (moisture) removal capacity, it is recommended that the energy recovery wheels be sprayed with a diluted nonacid based evaporator coil cleaner or alkaline detergent solution such as 409.

NOTE: Do not use acid based cleaners, aromatic solvents, temperatures in excess of 170°F or steam. Damage to the wheel may result.

Do not disassemble and immerse the entire heat wheel in a soaking solution, as bearing and other damage may result.

3. Rinse wheel thoroughly after application of the cleaning solution, and allow to drain before reinstalling.
4. No re-lubrication is required to heat wheel bearings of the drive motor, or to the intake and exhaust blower motors.
5. If any belt chirping or squealing noise is present, apply a small amount of LPS-1 or equivalent dry film lubricant to the belt.

FIGURE 2 BELT REPLACEMENT INSTRUCTIONS

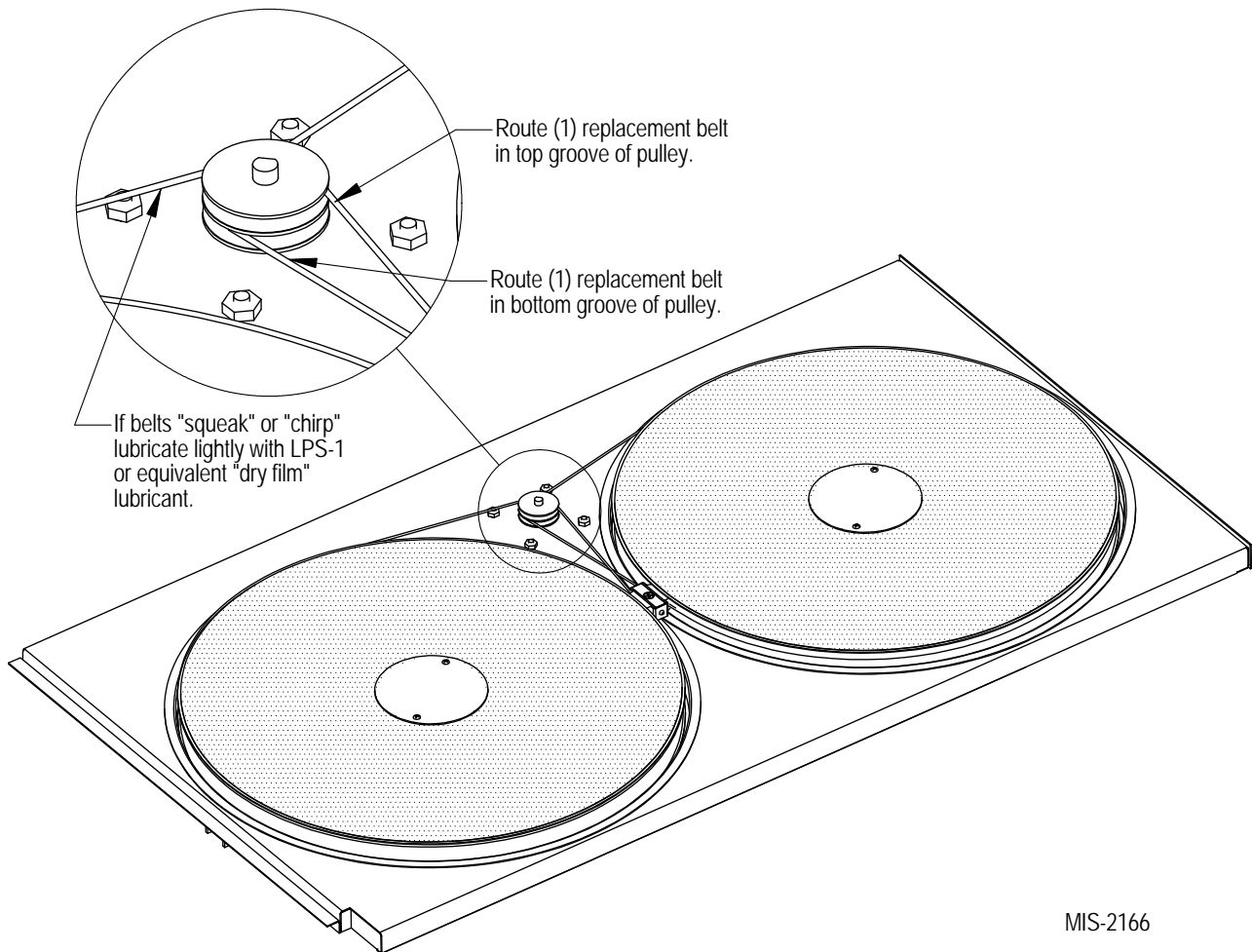
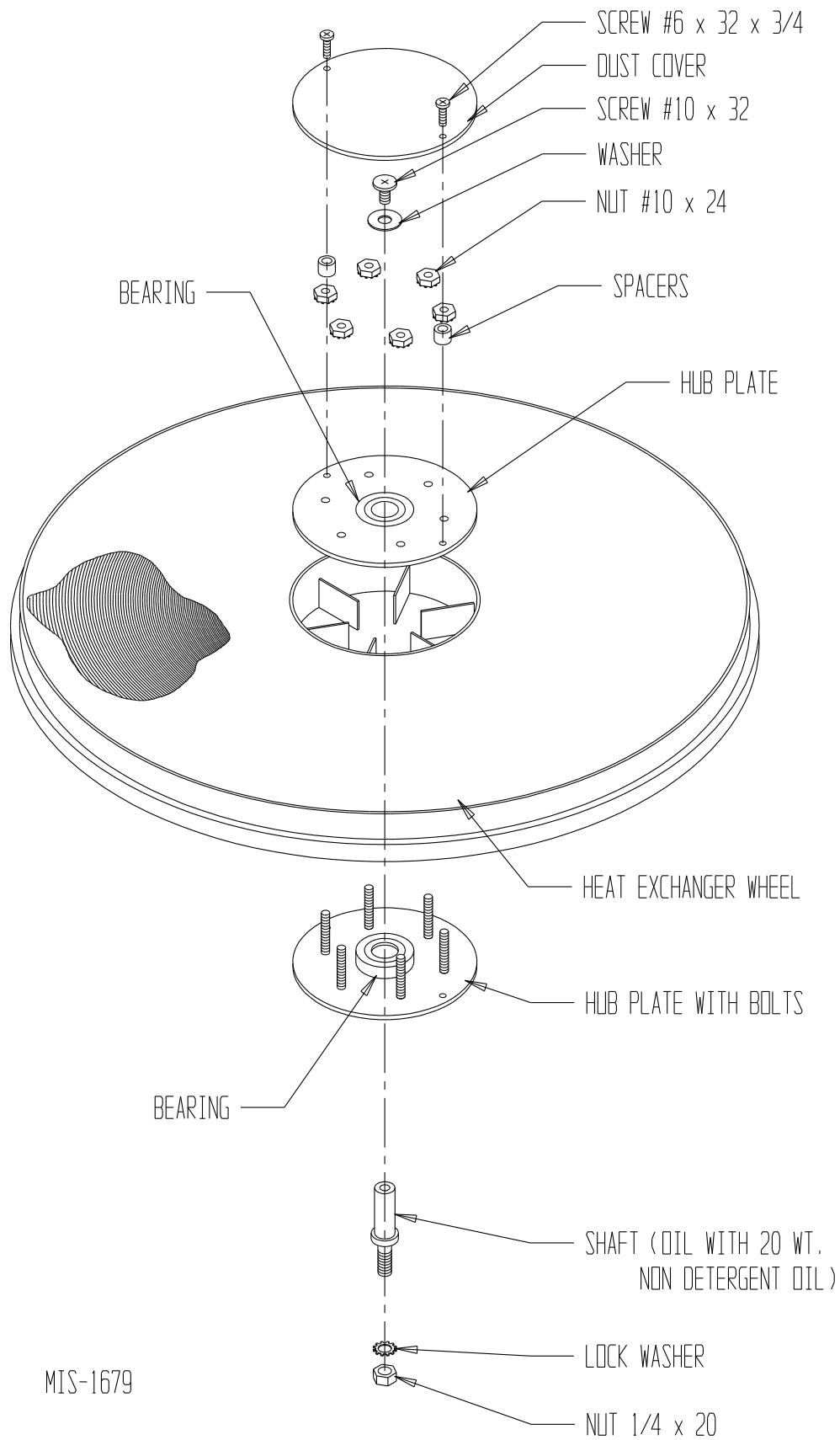
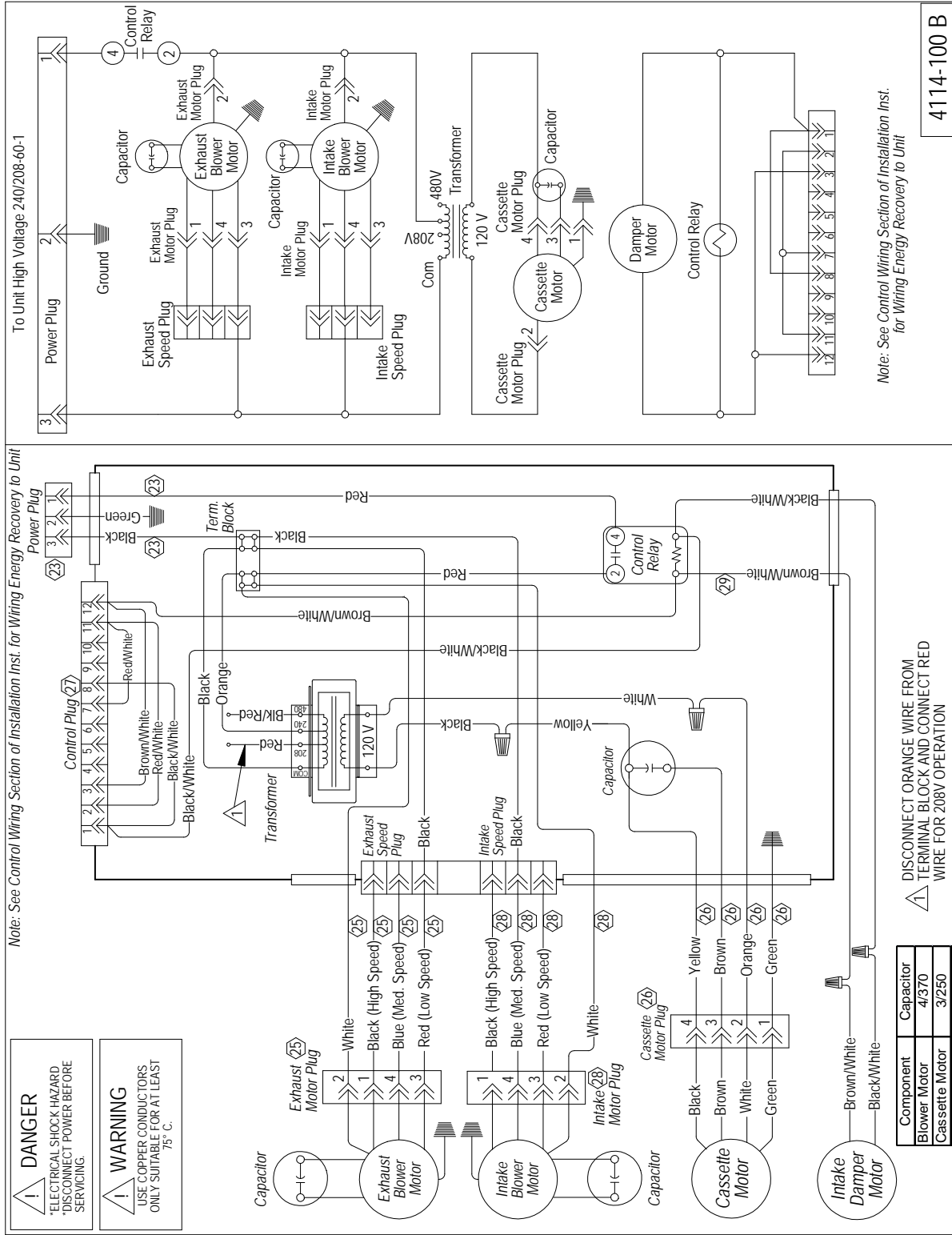

FIGURE 3
HUB ASSEMBLY WITH BALL BEARINGS



MIS-1679

WIRING DIAGRAM FOR 920-0074 QWSERV



Note: See Control Wiring Section of Installation Inst. for Wiring Energy Recovery to Unit

To Unit High Voltage 240/208-60-1

⚠ DANGER
*ELECTRICAL SHOCK HAZARD
*DISCONNECT POWER BEFORE SERVICING.

⚠ WARNING
USE COPPER CONDUCTORS
ONLY SUITABLE FOR AT LEAST
75° C.

Note: See Control Wiring Section of Installation Inst. for Wiring Energy Recovery to Unit

4114-100 B

DISCONNECT ORANGE WIRE FROM TERMINAL BLOCK AND CONNECT RED WIRE FOR 208V OPERATION

WIRING DIAGRAM FOR 920-0138 QWSERV WITH INTELLIGENT DEFROST

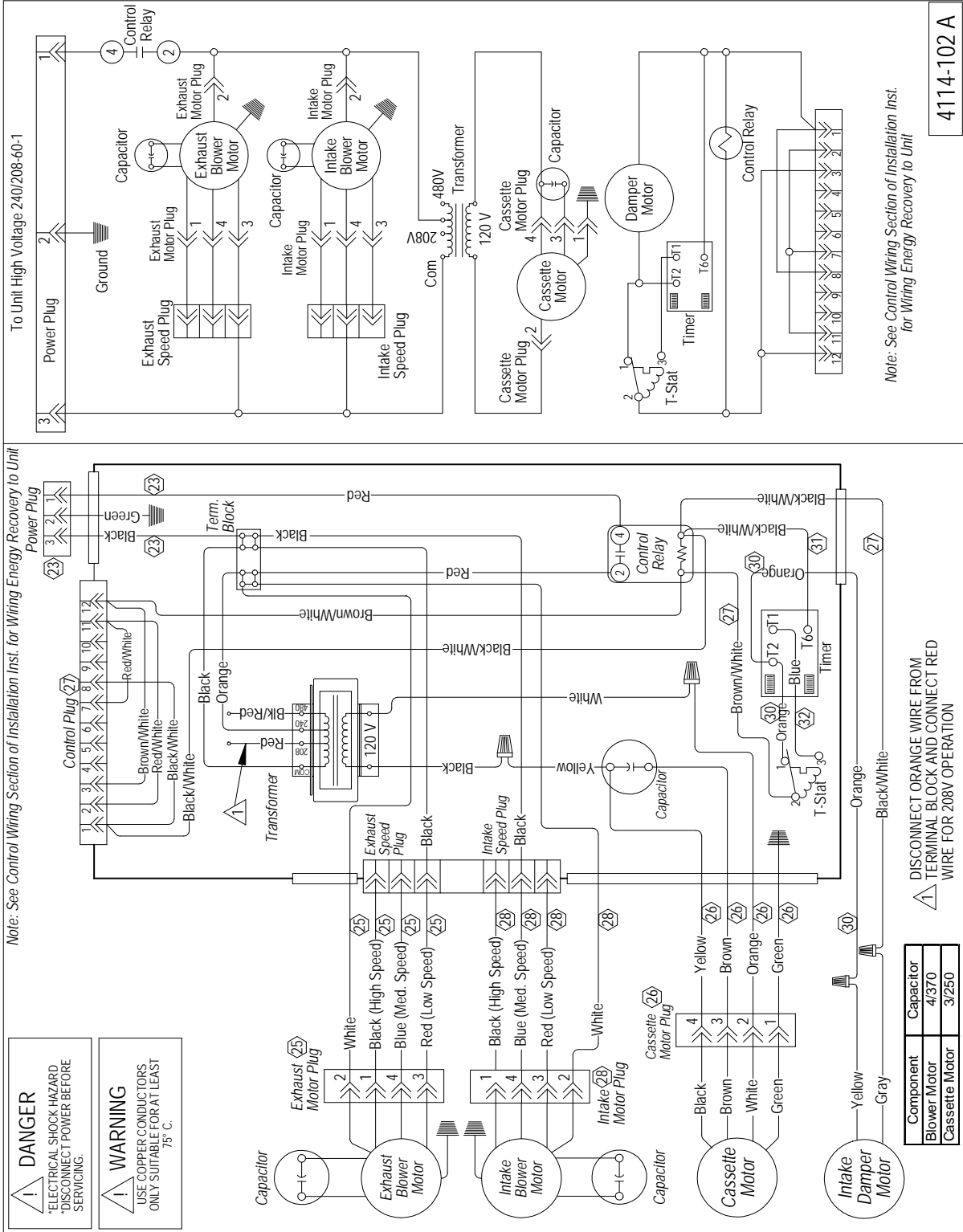

Note: See Control Wiring Section of Installation Inst. for Wiring Energy Recovery to Unit

4114-102 A

FIGURE 4
DISCONNECT & TAPE OFF WIRE

