

WATER SOURCE HEAT PUMPS

MODELS:

INSTALLATION INSTRUCTIONS

GTB1-A	Blower Section
GTA3600UD1-A	Coil Section
GTA3600UD1AA	Coil Section
GTA4860UD1-A	Coil Section
GTA4860UD1AA	Coil Section
GTC36S1-ADCX	Compressor Section
GTC48S1-ADCX	Compressor Section
GTC60S1-ADCX	Compressor Section
GTC36S1-ADNX	Compressor Section
GTC48S1-ADNX	Compressor Section
GTC60S1-ADNX	Compressor Section

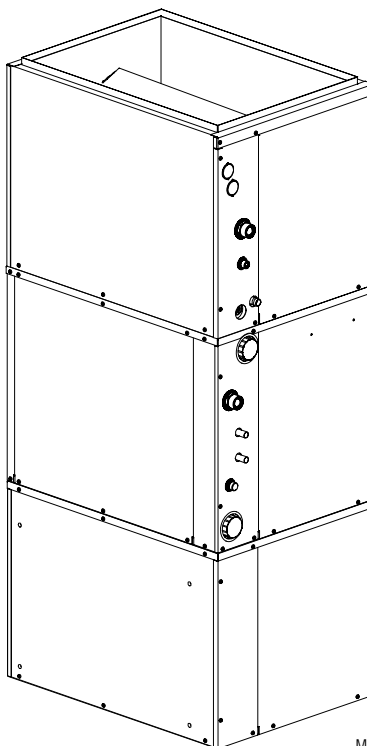

MIS-2830

**Earth Loop Fluid
Temperatures 25° - 110°
Ground Water Temperatures 45° - 75°**

BMC, Inc.
Bryan, Ohio 43506

Manufactured under the following
U.S. patent number:
8,127,566

Manual: 2100-537G
Supersedes: 2100-537F
File: Volume I, Tab 8
Date: 06-21-12

CONTENTS

Getting Other Informations and Publications	3	Installation Procedure - General	31
General Information Geo-Trio (GT Series)		Oper. of Heat Recovery Unit	32
Water Source Nomenclature	4	Start Up & Checkout	32
"A" Coil, Blower & Compressor Sections	4	Maintenance	32
Blower Conversion & Line Power Connect	14	Sequence of Operation	
Application and Location		Blower	37
General	17	Part / Full Load Cooling	37
Shipping Damage	17	Part / Full Load Heating	37
Application	17	Supplementary Electric Heat	37
Location	17	Geothermal Logic Controls	37
Ductwork	17	High / Low Pressure Switch	38
Filters	18	Freeze Stat	38
Condensate Drain	18	Condensate Overflow	38
Piping Access to Unit	18	Under/Over Voltage Protection	38
Wiring Instructions		Intelligent Reset	38
General	21	Alarm Output	38
Control Circuit Wiring	21	Pressure Service Ports	38
Wall Thermostats & Low Voltage Connections	21	System Start Up	38
Ground Loop (Earth Coupled Water Loop Applications)		Refrigerant Charge	
Note	23	Line Set Installation	41
Circulation System Design	23	Charge Adjustment	41
Start Up Procedure for Ground Loop System	24	Refrigerant Fitting Attachment	41
Ground Water (Well System Applications)		Checking Charge Quantity	41
Note	26	General / Topping Off System / Safety Practices ...	42
Water Connections	26	Service	
Well Pump Sizing	26 & 27	Service Hints	45
Start Up Procedure for Ground Water System	28	Unbrazing System Components	45
Water Corrosion	28 & 29	Compressor Solenoid	45
Remedies of Water Problems	29	Troubleshooting GE ECM 2.3 Motors	46 & 47
Lake and/or Pond Installations	29 & 30	Troubleshooting Table	48
Desuperheater		Power Connector Table	48
Description	31	Ground Source Heat Pump	
Location	31	Performance Report	49-50
Electrical Connection	31	Wiring Diagrams	51-52

Figures

Figure 1A GTA****UD1-A Dimensions	7
Figure 1B GTB1-A Dimensions	8
Figure 1C GTC**S1-D Dimensions	9
Figure 1D Assembled Upflow/Counterflow App.	10
Figure 1E Horizontal App. Dimensions	11
Figure 2A Upflow & Counterflow Ducting Config. ...	12
Figure 2B Horiz. & Counterflow Ducting Config.	13
Figure 3 Blower Configuration	15
Figure 4 Blower Power Connections	16
Figure 5A Upflow Air Filter Applications	20
Figure 5B Counterflow Air Filter Applications	20
Figure 5C Horiz. Left Discharge Air Filter App.	20
Figure 5D Horiz. Front Discharge App.	20
Figure 6 Thermostat Wiring	22
Figure 7 Circulation System Design	23
Figure 8 Temperature & Pressure Measurement .	25
Figure 9 Perf. Model DORFC-1 Flow Ctr.	25
Figure 10 Perf. Model DORFC-2 Flow Ctr.	25
Figure 11 Water Connection Components	27
Figure 12 Cleaning Water Coil	29
Figure 13 Lake or Pond Installation	30
Figure 14 Wiring Diagram	33

Figure 15A Desuperheater Single Tank System	34
Figure 15B Desuperheater Dual Tank System	35
Figure 16 Thermistor	36
Figure 17 Component Location	39
Figure 18 Control Panel	39
Figure 19 Refrigerant Flow Diagrams	40
Figure 20 Pre-Charged Line Set Qty.	41
Figure 21 Pressure Tables	43
Figure 22 Control Disassembly	47
Figure 23 Winding Test	47
Figure 24 Drip Loop	47
Figure 25 Control Connector Motor Half	48

Tables

Table 1 Indoor Blower Performance	4
Table 2 Flow Rates for Various Fluids	5
Table 3 Specifications	5
Table 4 Water Coil Pressure Drop	6
Table 5 Electrical Heat Specifications	18
Table 6 Filter Sizing Chart	19
Table 7 Control Circuit Wiring	21
Table 8 Constant Flow Valves	26
Quick Reference Troubleshooting Chart	44

GETTING OTHER INFORMATION AND PUBLICATIONS

These publications can help you install the air conditioner or heat pump. You can usually find these at your local library or purchase them directly from the publisher. Be sure to consult current edition of each standard.

National Electrical Code ANSI/NFPA 70

Standard for the Installation ANSI/NFPA 90A
of Air Conditioning and Ventilating Systems

Standard for Warm Air ANSI/NFPA 90B
Heating and Air Conditioning Systems

Load Calculation for Residential ACCA Manual J
Winter and Summer Air Conditioning

Duct Design for Residential ACCA Manual D
Winter and Summer Air Conditioning and Equipment
Selection

Closed-Loop/Ground Source Heat Pump IGSHPA
Systems Installation Guide

Grouting Procedures for Ground-Source IGSHPA
Heat Pump Systems

Soil and Rock Classification for IGSHPA
the Design of Ground-Coupled Heat Pump Systems

Ground Source Installation Standards IGSHPA

Closed-Loop Geothermal Systems IGSHPA
– Slinky Installation Guide

FOR MORE INFORMATION, CONTACT THESE PUBLISHERS:

ACCA Air Conditioning Contractors of America
1712 New Hampshire Avenue
Washington, DC 20009
Telephone: (202) 483-9370
Fax: (202) 234-4721

ANSI American National Standards Institute
11 West Street, 13th Floor
New York, NY 10036
Telephone: (212) 642-4900
Fax: (212) 302-1286

**ASHRAE American Society of Heating Refrigerating,
and Air Conditioning Engineers, Inc.**
1791 Tullie Circle, N.E.
Atlanta, GA 30329-2305
Telephone: (404) 636-8400
Fax: (404) 321-5478

NFPA National Fire Protection Association
Batterymarch Park
P.O. Box 9101
Quincy, MA 02269-9901
Telephone: (800) 344-3555
Fax: (617) 984-7057

**IGSHPA International Ground Source
Heat Pump Association**
490 Cordell South
Stillwater, OK 74078-8018

Geo-Trio™ GT Series Geothermal / Water Source Heat Pump Nomenclature

"A" Coil Section

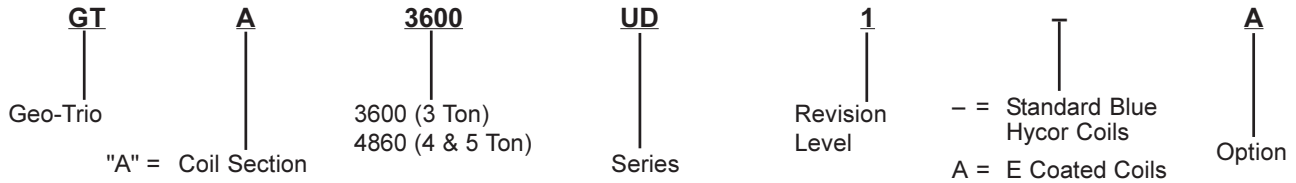

Blower Section

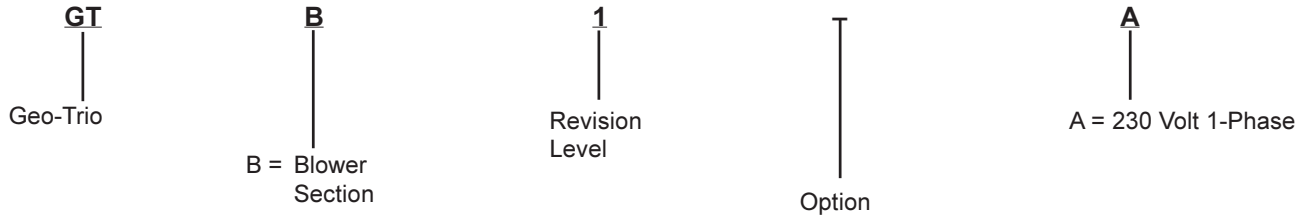

Compressor Section

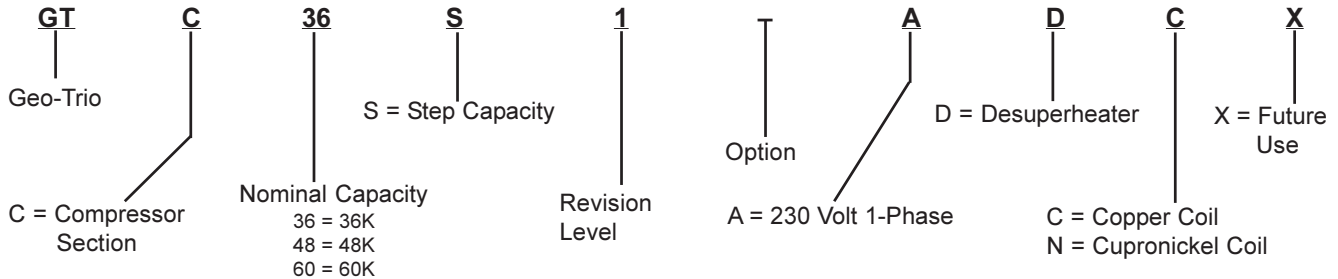

TABLE 1
INDOOR BLOWER PERFORMANCE (RATED CFM) ①

MODEL	② Rated ESP	③ MAX ESP	④ Continuous Airflow	⑤ Mild Climate Operation in Part Load Cooling	⑥ Part Load Airflow	Full Load Airflow	⑦ Electric Heat Airflow	⑧ Minimum Air Filter Face Area Ft. ²
GTC36S1	0.15	0.60	600	700	850	1200	1300	2.6
GTC48S1	0.20	0.60	750	875	1075	1500	1600	3.2
GTC60S1	0.20	0.60	900	1050	1300	1800	1800	3.6

- ① Motor will automatically step through the various airflows with thermostatic control
- ② ESP = External Static Pressure (inches of water)
- ③ Maximum allowable duct static
- ④ Continuous airflow is the CFM being circulated with manual fan operation without any additional function occurring.
- ⑤ Will occur automatically for first 5 minutes of Part Load Cooling Operation.
- ⑥ Will occur automatically after five minutes of Part Load Cooling Operation.
- ⑦ Will occur automatically with control signal input.
- ⑧ As per ASHRAE Guidelines of 500 FPM Velocities.

NOTE: All values can be changed ± 10% via the ± adjustment dip switches on the tap select control inclusive in the GTB1-A Blower Section (see instructions later in this manual, or on wiring diagram in blower section).

**TABLE 2
FLOW RATES FOR VARIOUS FLUIDS**

APPLICATION	MODELS		
	GTC36S1	GTC48S1	GTC60S1
Ground Loop (15% Methanol, Propylene Glycol, etc.)	8	12	15
Ground Water	6	7	9
Water Loop (Cooling Tower)	9.2	12.1	14.3

**TABLE 3
SPECIFICATIONS**

MODEL	GTC36S1	GTC48S1	GTC60S1
Electrical Rating (60HZ/1PH)	230/208-60-1		
Operating Voltage Range	253-197 VAC		
Minimum Circuit Ampacity	26.0	34.0	38.0
+Field Wire Size	#8	#6	#4
Ground Wire Size	#10	#8	#6
++Delay Fuse or Circuit Breaker Max.	40	50	60
COMPRESSOR			
Volts	230/208-60-1		
Rated Load Amps (230/208)	11.2 / 13.0	16.4 / 19.6	19.2 / 23.6
Branch Circuit Selection Current	16.7	21.2	25.6
Locked Rotor Amps (230/208)	82 / 82	96 / 96	118 / 118
BLOWER MOTOR			
Horsepower (ECM Motor)	3/4 Variable Speed		
Volts	230/208-60-1		
Motor Amps (Stage #2 @ Rated CFM)	3.4	4.3	4.4
FLOW CENTER (Based on DORFC-2)			
Volts	230/208-60-1		
Amps	2.14	2.14	2.14
DESUPERHEATER PUMP MOTOR			
Volts	230/208-60-1		
Amps	0.15	0.15	0.15

+75°C copper wire ++ HACR type circuit breaker

**TABLE 4
WATER COIL PRESSURE DROP**

Model	GTC36S1		GTC48S1		GTC60S1		
	GPM	PSID	Ft. Hd.	PSID	Ft. Hd.	PSID	Ft. Hd.
3	0.1	0.23					
4	0.5	1.15	0.9	2.08			
5	1.2	2.77	1.4	3.23			
6	1.7	3.92	2.3	5.31			
7	2.3	5.31	3.2	7.38	2	4.61	
8	3.1	7.15	4.1	9.46	2.5	5.77	
9	4.1	9.46	5.1	11.77	3.2	7.38	
10			6.1	14.07	3.9	9.00	
11			7.1	16.38	4.7	10.84	
12			8.2	18.92	5.5	12.69	
13			9.4	21.69	6.4	14.76	
14			10.6	24.45	7.3	16.84	
15					8.1	18.69	
16					9	20.76	
17					9.9	22.84	
18							

FIGURE 1A – GTA**UD1-A
A-COIL SECTION DIMENSIONS**

GTA Coil Dimensions If Used Without Cabinet

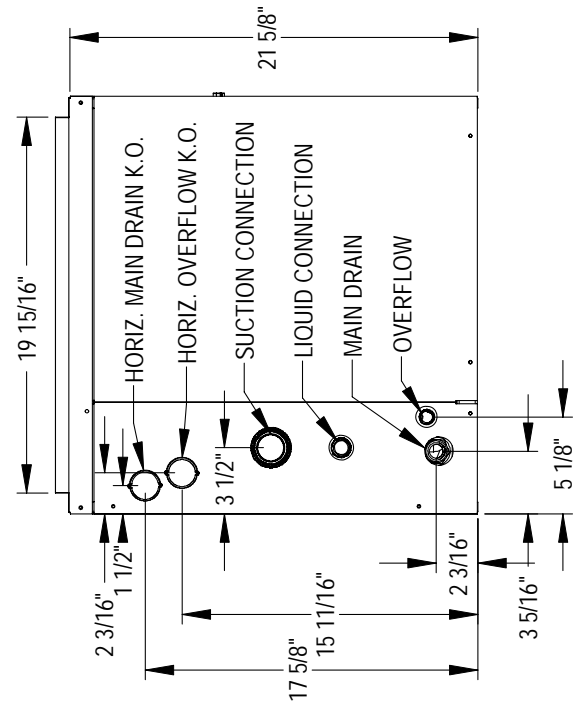
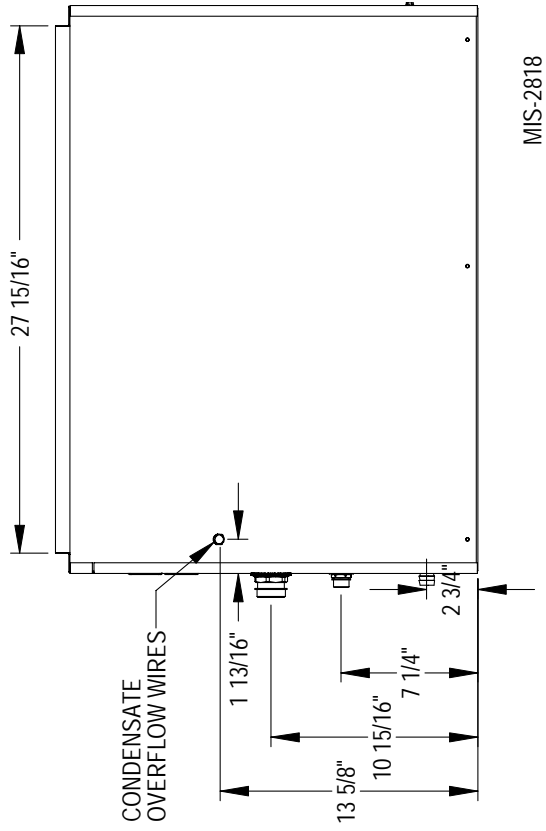
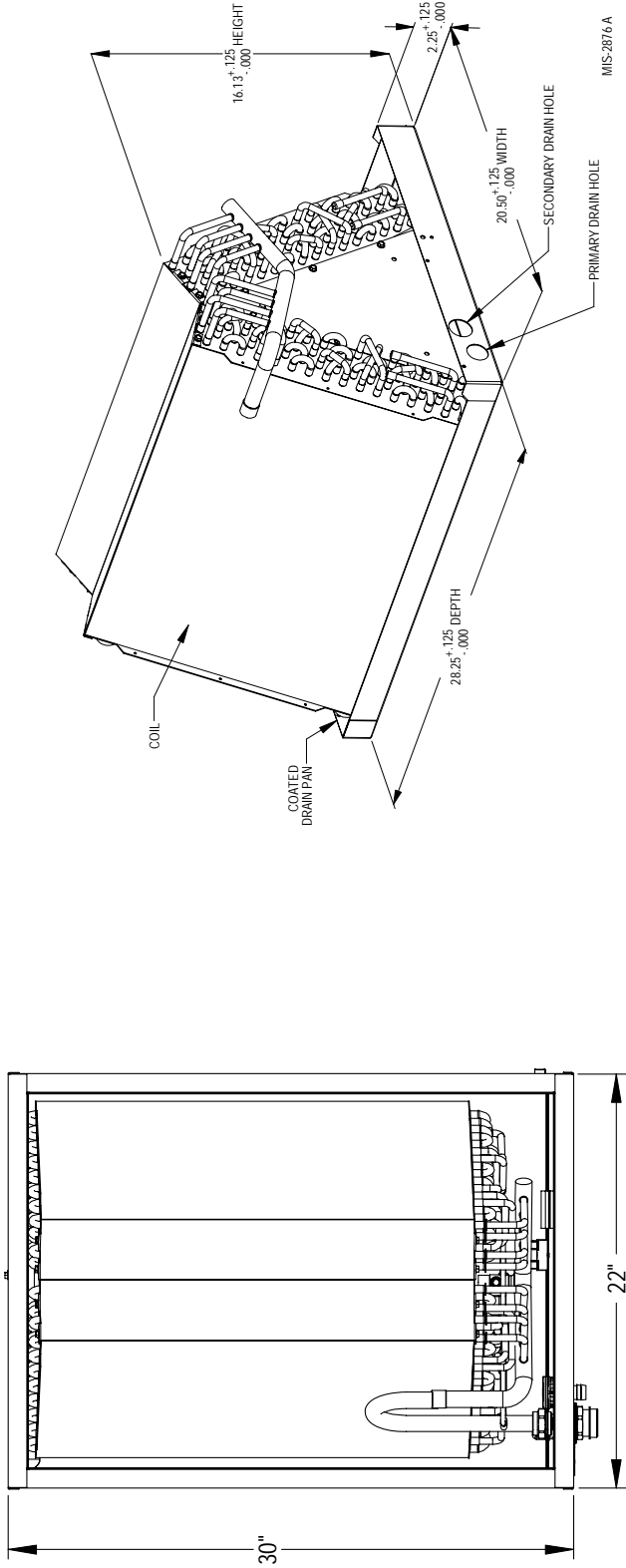

**FIGURE 1B – GTB1-A
BLOWER SECTION DIMENSIONS**

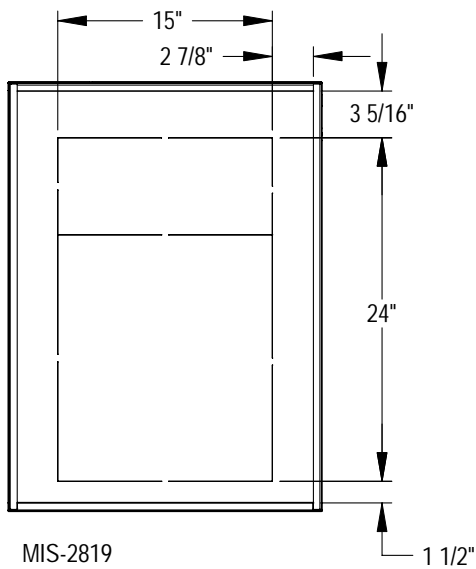
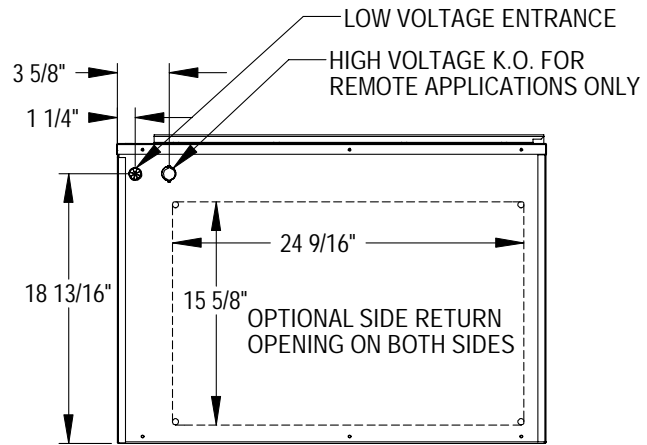
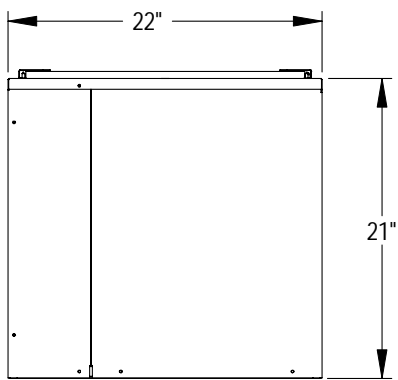
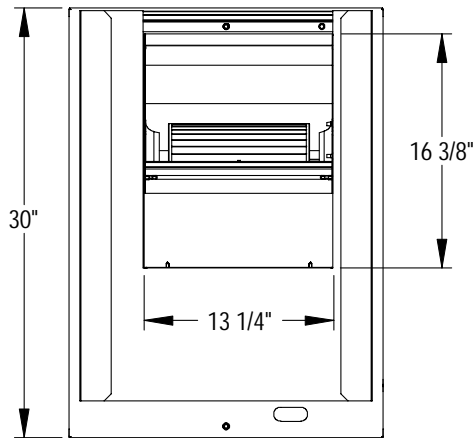
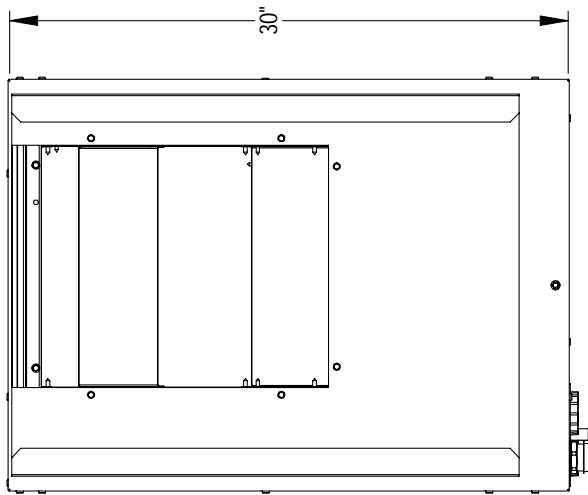
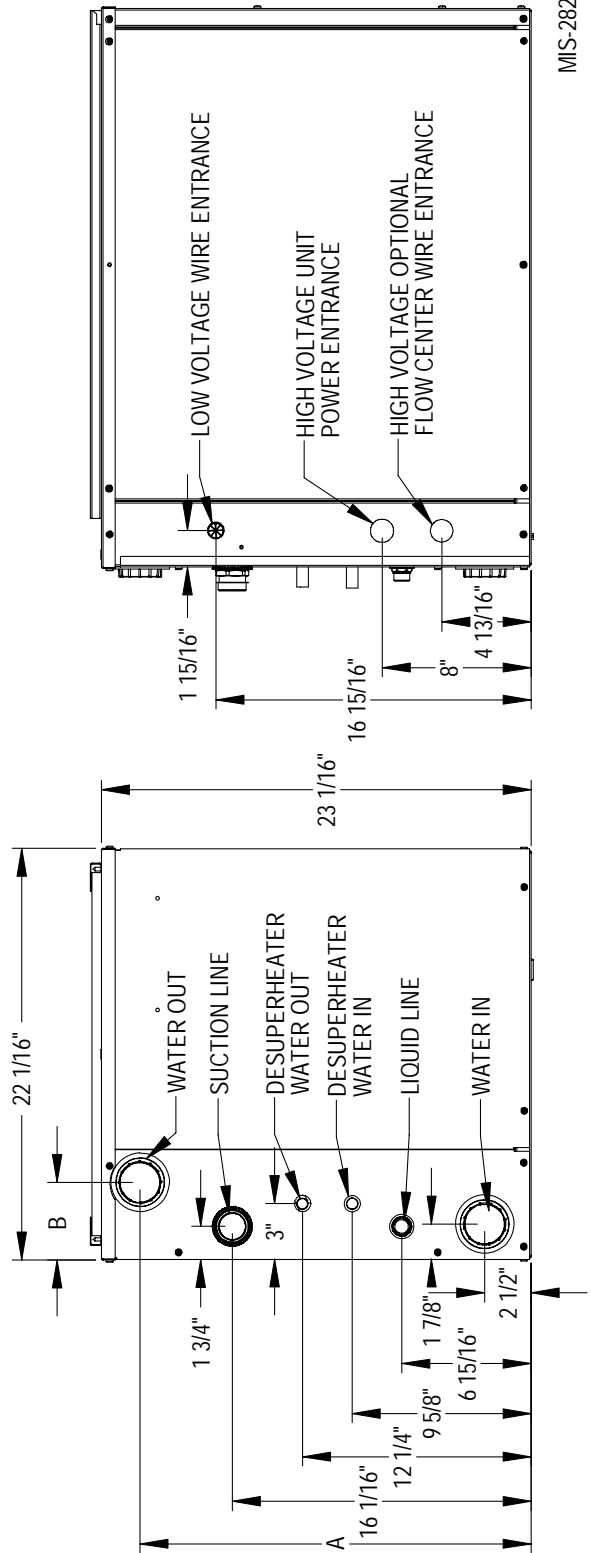

FIGURE 1C – GTCS1-D
COMPRESSOR SECTION DIMENSIONS**



MODEL	DIM. A	DIM. B
GTC36S1	21"	4 1/8"
GTC48S1	20"	3 7/8"
GTC60S1	18 1/2"	3 3/4"



MIS-2820

FIGURE 1D – ASSEMBLED UPFLOW / COUNTERFLOW APPLICATION DIMENSIONS

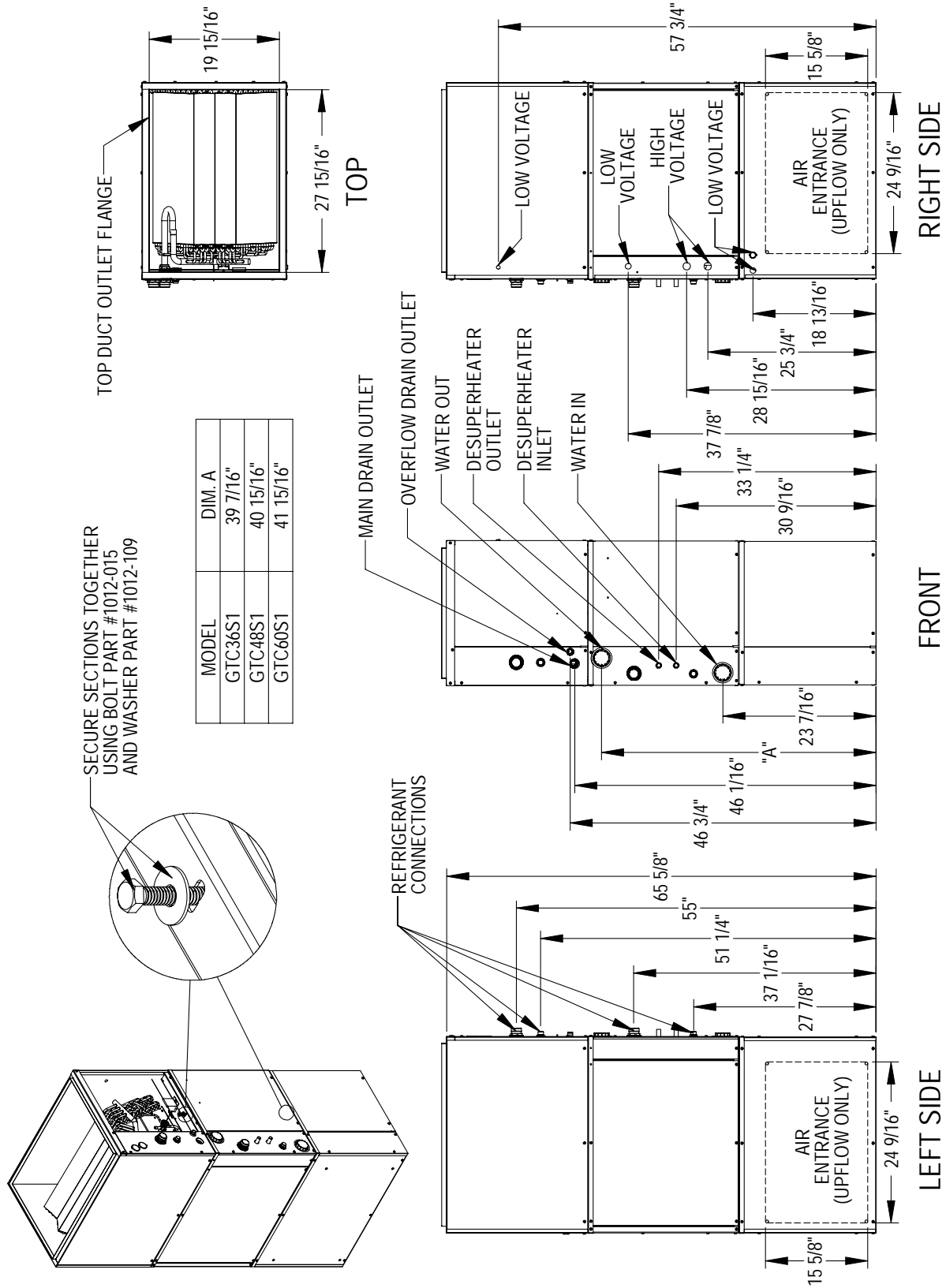

MIS-2821

FIGURE 1E – HORIZONTAL APPLICATION DIMENSIONS

*Evaporator and Blower in Horizontal Position
(Remote Compressor Section)*

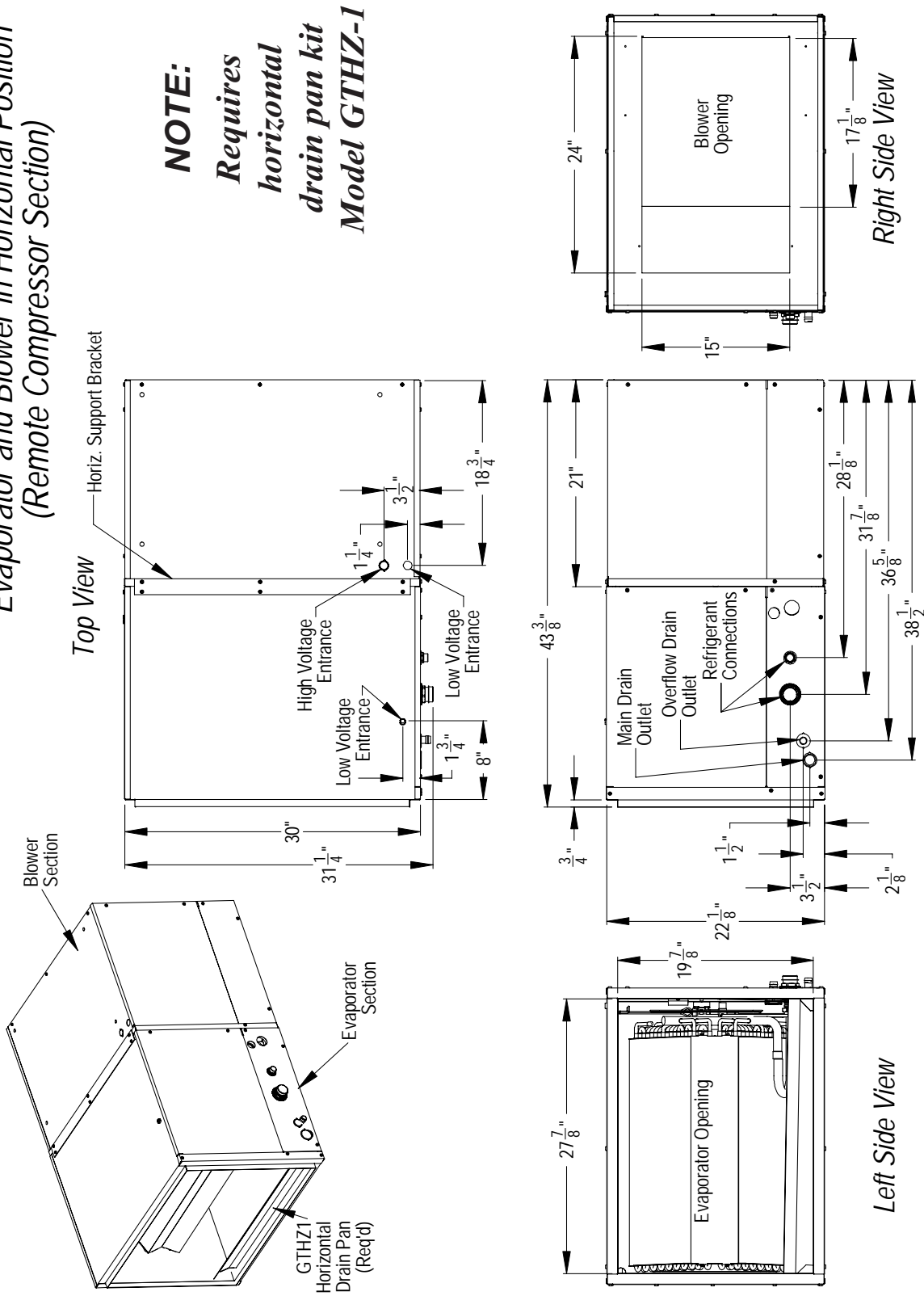

MIS-2824

FIGURE 2A – UPFLOW & COUNTERFLOW DUCTING CONFIGURATIONS

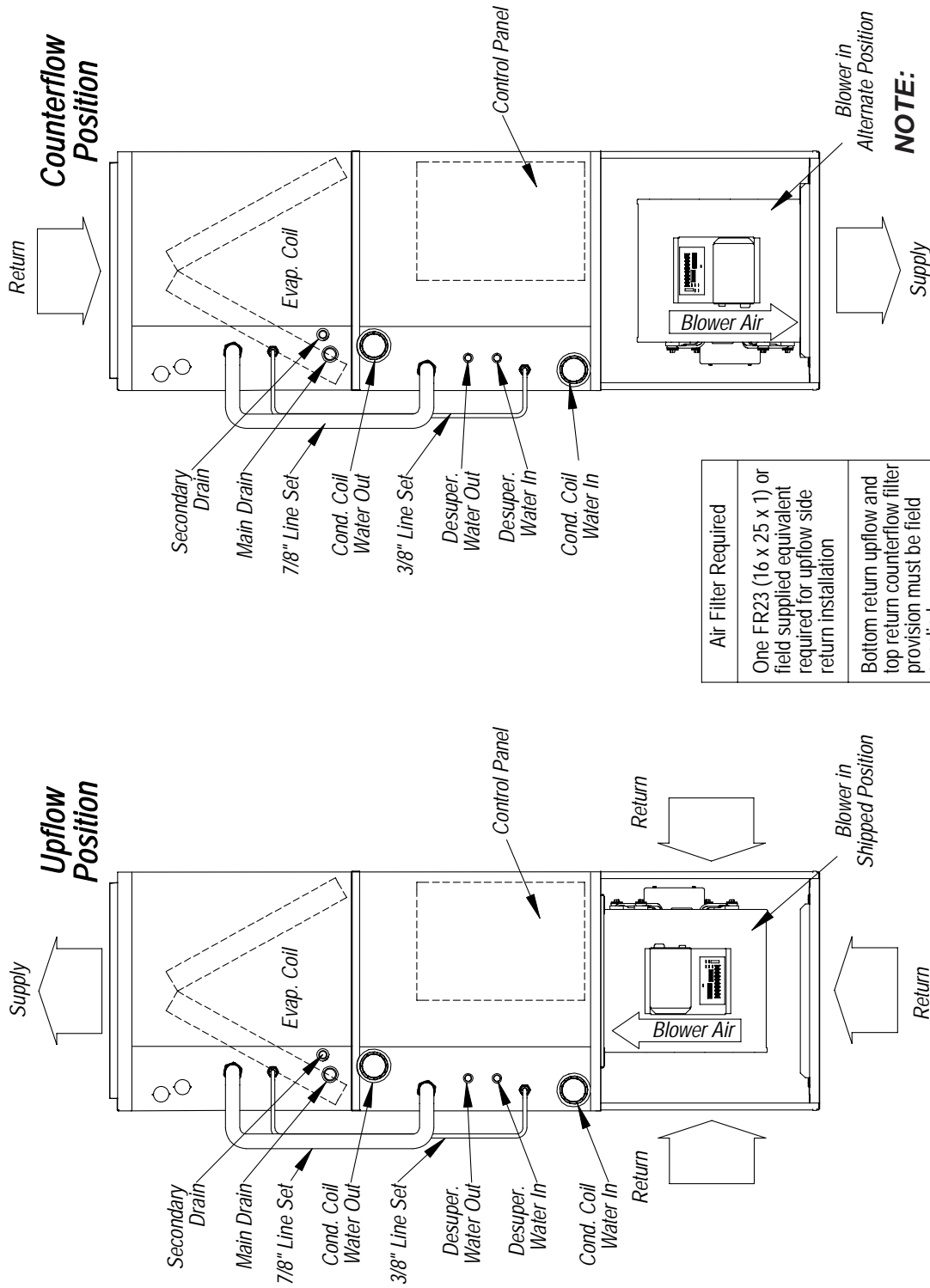

Air Filter Required
One FR23 (16 x 25 x 1) or field supplied equivalent required for upflow side return installation
Bottom return upflow and top return counterflow filter provision must be field supplied

NOTE:
Requires Switch #4 on Tap Select Control to be Turned On.

MIS-2828

FIGURE 2B – HORIZONTAL & COUNTERFLOW DUCTING CONFIGURATIONS

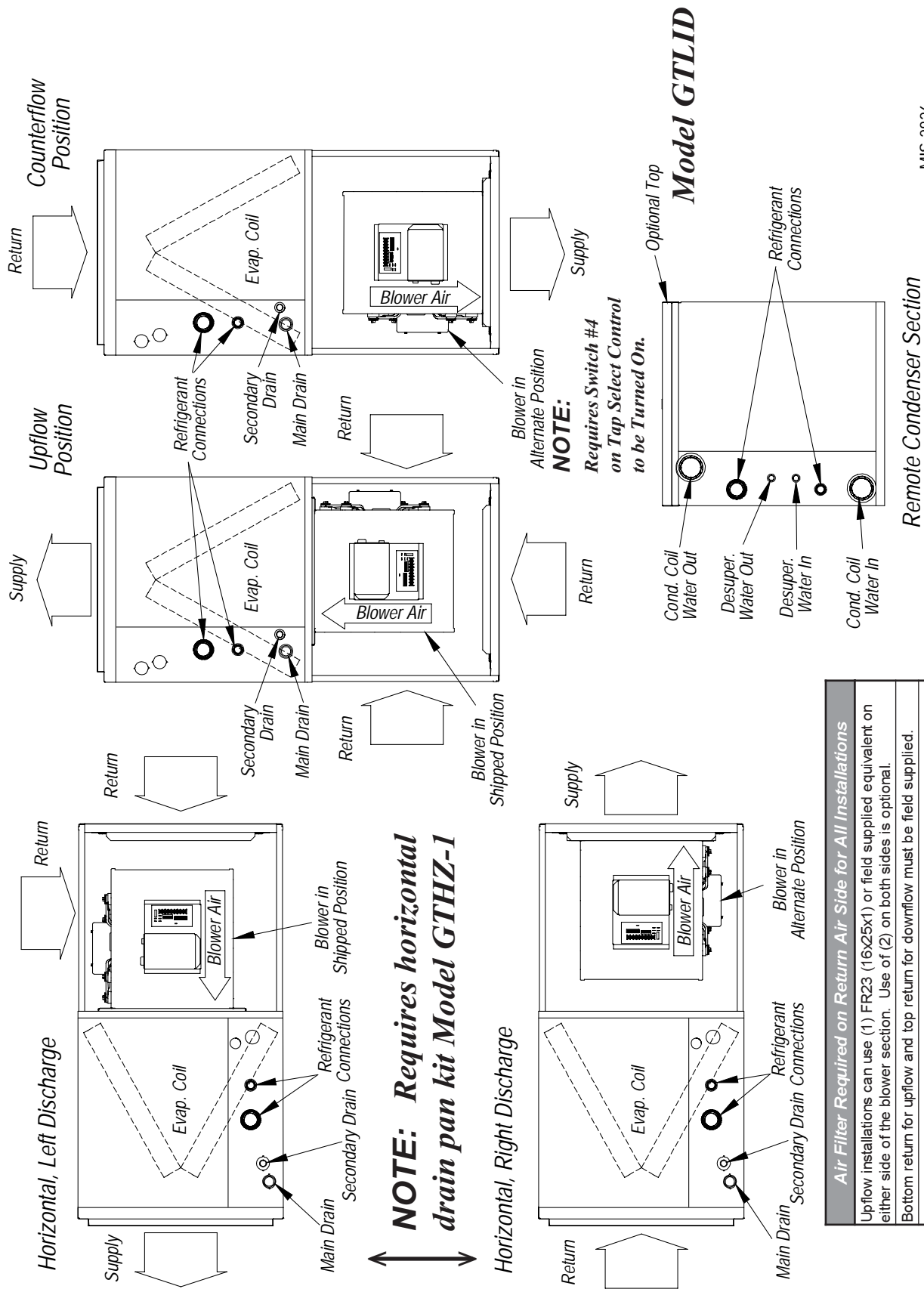

Air Filter Required on Return Air Side for All Installations

Upflow installations can use (1) FR23 (16x25x1) or field supplied equivalent on either side of the blower section. Use of (2) on both sides is optional.

Bottom return for upflow and top return for downflow must be field supplied.

For horizontal attic or crawl space installations filter arrangement must be field supplied & should be located in readily accessible location for the user.

See additional information on Pages 19 & 20.

MIS-2826

BLOWER CONVERSION FROM UPFLOW TO COUNTERFLOW OR HORIZONTAL RIGHT DISCHARGE

Following the directions on Figure 3 for counterflow and horizontal right discharge, the indoor blower must be removed and turned over in its mounting configuration.

- **Step 1** Remove both front service panels from the GTB1-A.
- **Step 2** Remove two screws securing blower at top of GTB1-A (See Figure 3), and slide the blower forward and out of the chassis.
- **Step 3** Remove two screws from front fill plate on bottom of GTB1-A, and slide both pieces of metal forward and out of chassis.
- **Step 4** Dip switch #4 on blower tap select control must be turned “on”. (Refer to Wiring Diagram 4117-100.)
- **Step 5** While turning on tap #4 above, adjust the other taps accordingly for the tonnage of unit being applied. (Refer to Wiring Diagram 4117-100.)
- **Step 6** Turn blower over and slide into rails of bottom rear of the GTB1-A front fill plate that was removed in Step 3 above.
- **Step 7** Remove bottom rear fill plate from bottom front fill plate (discard rear), and resecure front fill plate into unit base and front of blower.
- **Step 8** Replace GTB1-A front service doors after making line and control voltage wiring connections.

BLOWER LINE POWER CONNECTION

Power connections for the GTB1-A can be made two different ways.

The first is in “stacked” configurations, the blower can be plugged into an electrical connection from the bottom of the compressor (GTC**S1 Model Unit). This will work for either upflow or counterflow applications. All electrical sizing has been sized to accommodate this.

The second is with “remote” blower (meaning separate from the compressor section). Supplied in the GTB1-A is an adaptor wire harness. On the right-hand side of the GTB1-A chassis is a ½" electrical knockout. This harness can be installed through this knockout with the supplied strain relief into a standard electrical junction box (field supplied). Electrical load sizing is included on the serial plate of the GTB1-A for the required separate branch circuit (See Figure 4).

FIGURE 3 – BLOWER CONFIGURATIONS

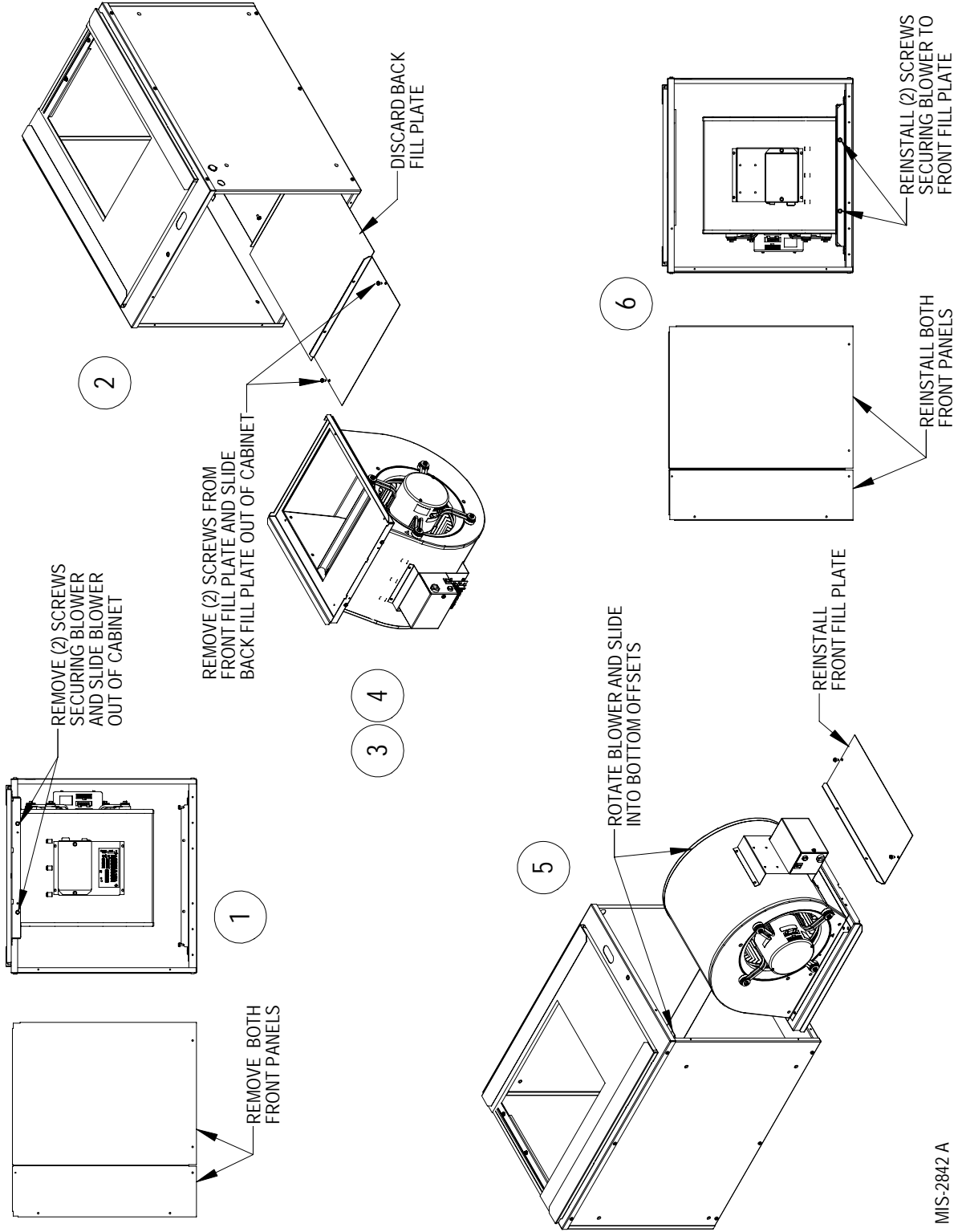

MIS-2842 A

FIGURE 4 – BLOWER POWER CONNECTIONS

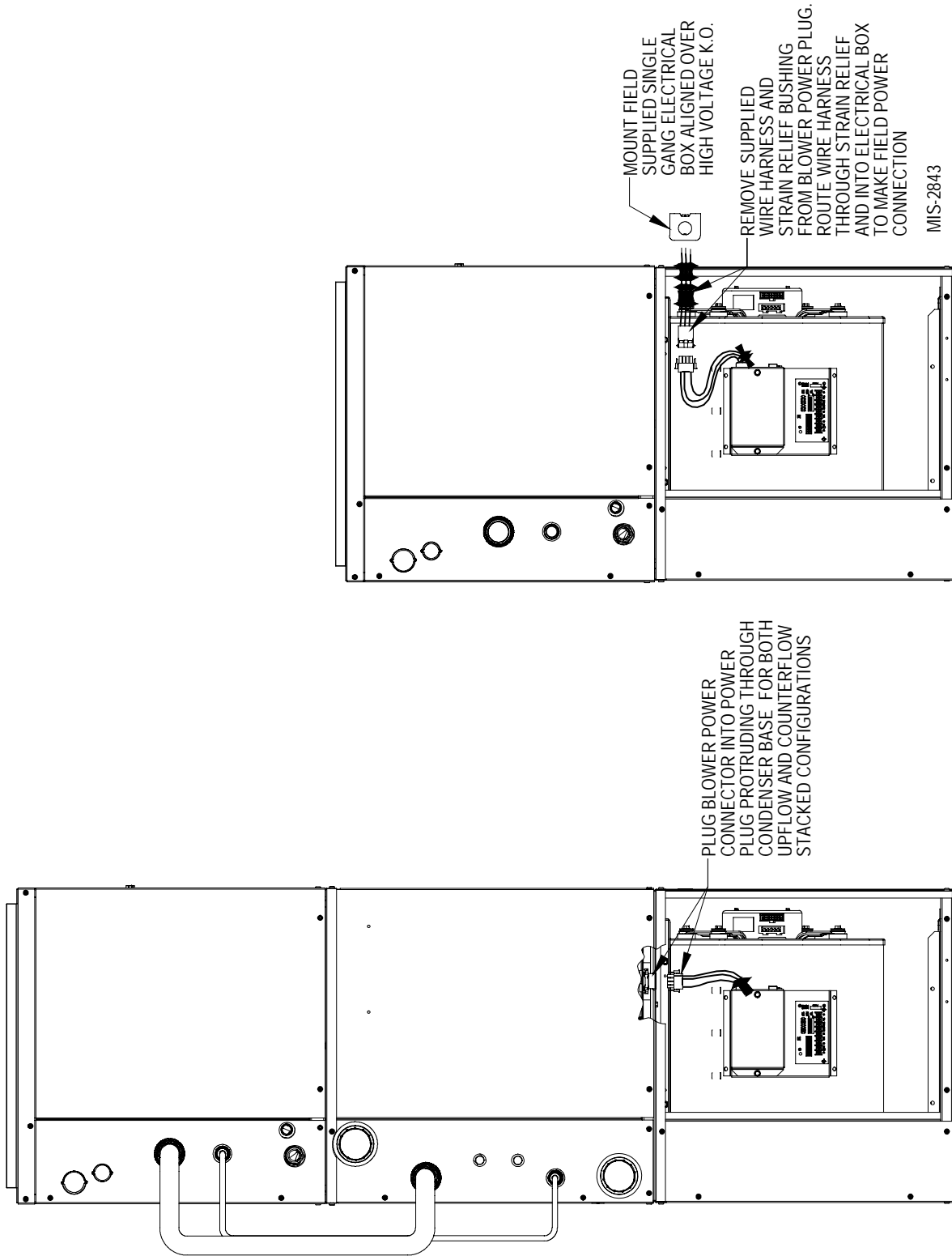

MIS-2843

APPLICATION AND LOCATION

GENERAL

The GT Series Geothermal Heat Pumps feature three sections (GTA - Air Coil Section, GTB - Blower Section and GTC - Compressor Section) which cover upflow (bottom, right/left-side return), counterflow and horizontal (left and right-hand discharge) applications.

The individual sections are shipped internally wired, requiring duct connections, thermostat wiring, 230/208 volt AC power wiring, refrigerant line connections and water piping. The equipment covered in this manual is to be installed by trained, experienced service and installation technicians.

These instructions and any instructions packaged with any separate equipment required to make up the entire heat pump system should be carefully read before beginning the installation. Note particularly any tags and/or labels attached to the equipment.

While these instructions are intended as a general recommended guide, they do not in any way supersede any national and/or local codes. Authorities having jurisdiction should be consulted before the installation is made.

SHIPPING DAMAGE

Upon receipt of the equipment, the carton should be checked for external signs of shipping damage. If damage is found, the receiving party must contact the last carrier immediately, preferably in writing, requesting inspection by the carrier's agent.

APPLICATION

Capacity of the unit for a proposed installation should be based on heat loss calculations made in accordance with methods of the Air Conditioning Contractors of America. The air duct system should be sized and installed in accordance with Standards of the National Fire Protection Association for the Installation of Air Conditioning and Venting systems of Other than Residence Type NFPA No. 90A, and residence Type Warm Air Heating and Air Conditioning Systems, NFPA No. 90B.

LOCATION

The unit may be installed in a basement, closet, or utility room provided adequate service access is ensured.

These units are not approved for outdoor installation and therefore must be installed inside the structure being conditioned. ***Do not locate in areas subject to freezing in the winter or subject to sweating in the summer.***

Before setting the unit, consider ease of piping, drain and electrical connections for the unit. Also, for units which will be used with a desuperheater unit, consider the proximity of the unit to the water heater or storage tank. Place the unit on a solid base, preferably concrete, to minimize undesirable noise and vibration. ***DO NOT*** elevate the base pan on rubber or cork vibration eliminator pads as this will permit the unit base to act like a drum, transmitting objectionable noise.

DUCTWORK

If the unit is to be installed in a closet or utility room which does not have a floor drain, a secondary drain pan under the entire unit is highly recommended.

DO NOT install the unit in such a way that a direct path exists between any return grille and the unit. Rather, insure that the air entering the return grille will make at least one turn before entering the unit or coil. This will reduce possible objectionable compressor and air noise from entering the occupied space.

Design the ductwork according to methods given by the Air Conditioning Contractors of America. When duct runs through unconditioned spaces, it should be insulated with vapor barrier. It is recommended that flexible connections be used to connect the ductwork to the unit in order to keep the noise transmission to a minimum.



WARNING

In applying a duct heater, refer to duct heater installation instructions for minimum clearance to combustible materials, maximum allowed inlet air temperatures, and minimum air volume requirements for KW usage.



CAUTION

NEVER OPERATE MORE THAN 10KW STRIP HEAT WITH GEOTHERMAL HEAT PUMP OPERATIONAL. USE ADDITIONAL KW STRIP HEAT BEYOND 10KW ONLY IN EMERGENCY HEAT MODE.

**TABLE 5
ELECTRICAL HEAT SPECIFICATIONS**

For Use With	Heater Package	Heater Package	240 Volts			208 Volts			Minimum Circuit Ampacity	Maximum HACR Circuit Breaker	Field Wire Size +
			KW	Amps	BTUH	KW	Amps	BTUH			
All GTC*S1 Models	8604-080	240/208-60-1	5.0	20.8	17,065	3.75	18.0	12,799	26.0	30	#10
	8604-081	240/208-60-1	9.8	40.8	33,447	7.35	35.3	25,086	52.0	60	#6
	8604-082	240/208-60-1	14.7	61.2	50,171	11.0	52.9	37,543	76.6	80	#4
	8604-083	240/208-60-1	19.2	81.7	65,530	14.4	69.2	49,147	102.0	125	#1

+ Based upon 75°C copper wire. All wiring must conform to National Electric Code (Latest Edition) and all local codes.

FILTER

This unit must NOT be operated without a filter installed on return air side of the system. Insufficient airflow due to undersized duct systems, inadequate filter size, or dirty filters can result in nuisance tripping of the high or low pressure controls. The ductwork and filter sizing must be designed per ASHRAE/ACCA Guidelines.

- Step #1** Refer to Table 1 (Page 4) for specific unit airflow and static application information.
- Step #2** Refer to Figures 5A, 5B, 5C and 5D (Page 20) for typical installation filter configurations for your specific application.
- Step #3** Refer to Table 6 Filter Sizing Chart (Page 19) matching your airflow and filter configuration to determine proper filter sizing.

CONDENSATE DRAIN

Drain lines must be installed according to local plumbing codes. It is not recommended that any condensate drain line be connected to a sewer main.

NOTE: *This drain line will contain cold water and must be insulated to avoid droplets of water from compressor on the pipe and dripping on finished floors or the ceiling below the unit.*

PIPING ACCESS TO UNIT

Water piping to and from the unit enters the unit cabinet on the left side of the unit. The connection directly at the unit is a special double o-ring fitting with a retainer nut that secures it in place. (It is the same style fitting used for the flow center connection on ground loop applications.)

NOTE: *All double o-ring fittings require "hand tightening only". Do not use wrench or pliers as retainer nut can be damaged with excessive force.*

NOTE: *Apply petroleum jelly to o-rings to prevent damage and to aid in insertion.*

Various fittings are available so you may then connect to the unit with various materials and methods. These methods include 1" barbed fittings (straight and 90°), 1" MPT (straight and 90°), and 1-1/4" hot fusion fitting (straight only) (see Figure 7).

**TABLE 6
FILTER SIZING CHART**

Filter Nominal Size	Surface Area FT ²	Filter Type	Airflow CFM Capability @ 300 FPM Velocity	Airflow CFM Capability @ 500 FPM Velocity	Airflow CFM Capability @ 625 FPM Velocity
10" X 20" X 1"	1.39	1" Fiberglass Disposable	415	Not Recommended	Not Recommended
12" X 20" X 1"	1.67		500		
14" X 20" X 1"	1.94		580		
14" X 25" X 1"	2.43		730		
16" X 20" X 1"	2.22		670		
16" X 25" X 1"	2.78		840		
20" X 20" X 1"	2.78		840		
20" X 25" X 1"	3.47		1050		
24" X 24" X 1"	4.00		1200		
10" X 20" X 2"	1.39	2" Std. Fiberglass Disposable	415	700	Not Recommended
12" X 24" X 2"	2.00		600	1000	
14" X 20" X 2"	1.94		580	975	
14" X 25" X 2"	2.43		730	1215	
16" X 20" X 2"	2.22		670	1120	
16" X 25" X 2"	2.78		840	1400	
20" X 20" X 2"	2.78		840	1400	
20" X 25" X 2"	3.47		1050	1750	
24" X 24" X 2"	4.0		1200	2000	
10" X 20" X 1"	1.39	1" Pleated Filter	425	700	Not Recommended
12" X 24" X 1"	2.00		600	1000	
14" X 20" X 1"	1.94		590	980	
14" X 25" X 1"	2.43		730	1215	
16" X 20" X 1"	2.22		670	1115	
16" X 25" X 1"	2.78		840	1400	
20" X 20" X 1"	2.78		840	1400	
20" X 25" X 1"	3.47		1050	1740	
24" X 24" X 1"	4.00		1200	2000	
10" X 20" X 2"	1.39	2" Pleated Filter	425	700	870
12" X 24" X 2"	2.00		600	1000	1250
14" X 20" X 2"	1.94		590	980	1215
14" X 25" X 2"	2.43		730	1215	1520
16" X 20" X 2"	2.22		670	1115	1400
16" X 25" X 2"	2.78		840	1400	1740
20" X 20" X 2"	2.78		840	1400	1740
20" X 25" X 2"	3.47		1050	1740	2170
24" X 24" X 2"	4.00		1200	2000	2500
12" X 24" X 4"	2	4" Pleated Filter	600	1000	1250
16" X 20" X 4"	2.22		670	1115	1400
20" X 20" X 4"	2.78		840	1400	1740
20" X 25" X 4"	3.47		1050	1740	2170
24" X 24" X 4"	4		1200	2000	2500

To self-calculate for additional filter sizes:

$\text{Airflow} / \text{Nominal Filter Size (FT}^2\text{)} = \text{Velocity}$

$1600 \text{ CFM} / 3.47 \text{ (20" x 25" filter)} = 461 \text{ FPM (feet per minute velocity)}$

AIR FILTER APPLICATIONS

FIGURE 5A

UPFLOW

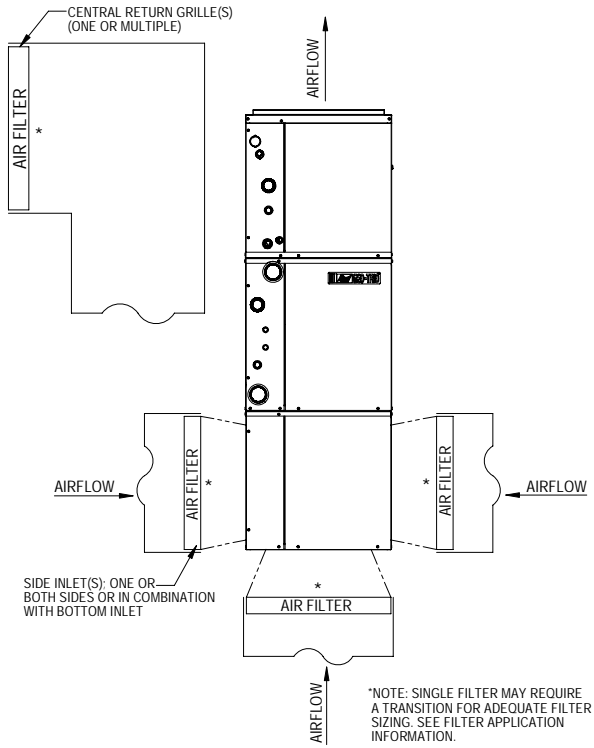

MIS-2881

FIGURE 5B

COUNTERFLOW

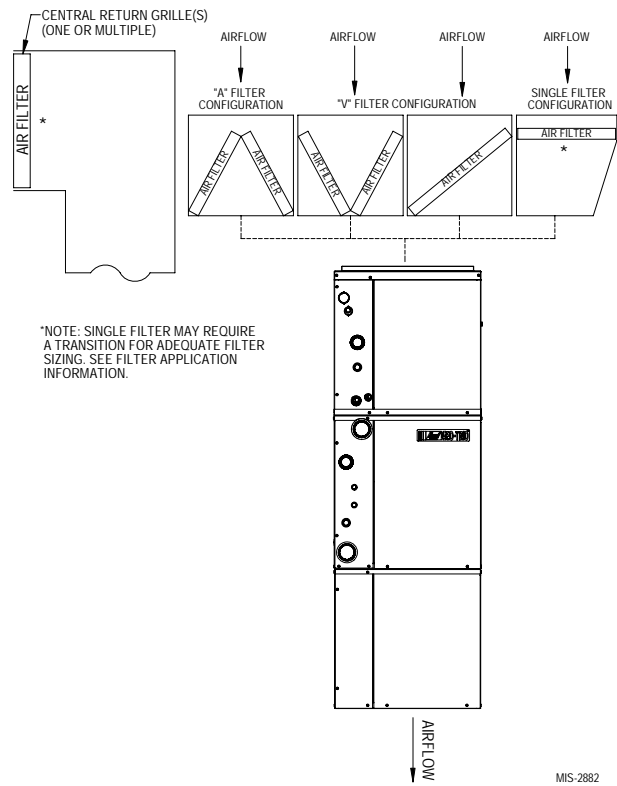

MIS-2882

FIGURE 5C

HORIZONTAL LEFT DISCHARGE

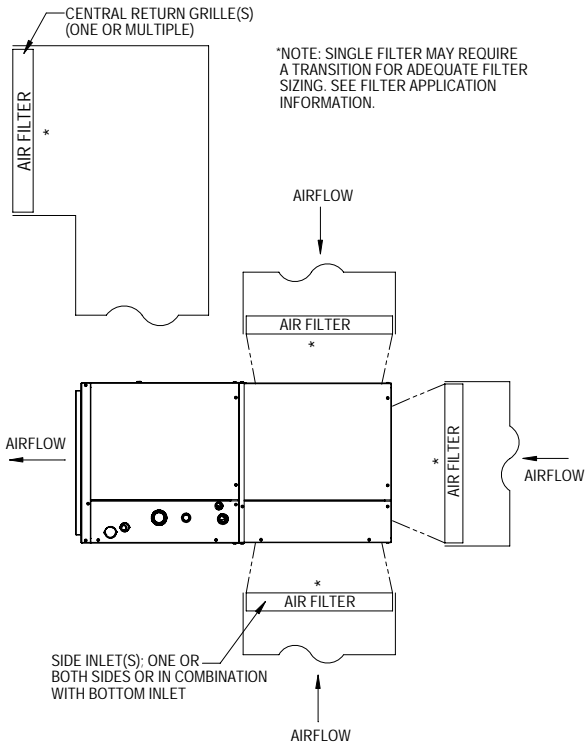

MIS-2883

FIGURE 5D

HORIZONTAL FRONT DISCHARGE

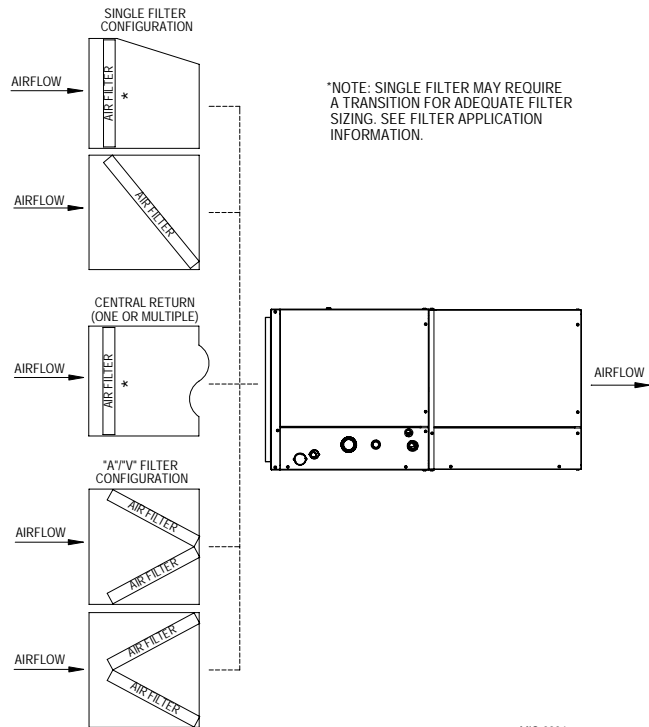

MIS-2884

FILTERS SHOULD ALWAYS BE APPLIED IN A MANNER THAT MAKES THEM EASY TO ACCESS & CHANGE.

WIRING INSTRUCTIONS

GENERAL

All wiring must be installed in accordance with the National Electrical Code and local codes. In Canada, all wiring must be installed in accordance with the Canadian Electrical Code and in accordance with the regulations of the authorities having jurisdiction. Power supply voltage must conform to the voltage shown on the unit serial plate. A wiring diagram of the unit is attached to the inside of the electrical cover. The power supply shall be sized and fused according to the specifications supplied. A ground lug is supplied in the control compartment for equipment ground.

The unit rating plate lists a “Maximum Time Delay Fuse” or “HACR” type circuit breaker that is to be used with the equipment. The correct size must be used for proper circuit protection and also to assure that there will be no nuisance tripping due to the momentary high starting current of the compressor motor.

CONTROL CIRCUIT WIRING

The minimum control circuit wiring gauge needed to insure proper operation of all controls in the unit will depend on two factors.

1. The rated VA of the control circuit transformer.
2. The maximum total distance of the control circuit wiring.

Table 6 should be used to determine proper gauge of control circuit wiring required.

For low voltage connections, see Figure #6. There are multiple options based upon the type of installation in regards to low voltage electrical connections and what options are selected. These options include a motorized valve or motorized valve with end switch for ground water applications, and optional electric duct heater connections.

NOTE: Review the “lettered triangles” and the corresponding notes on the lower right-hand corner of Figure #6. When options are not used, the wires will need attached to the reference points accordingly.

Example: 1. Control Circuit transformer rated at 50 VA
2. Maximum total distance of control circuit wiring 85 feet.

From Table 7 minimum of 16 gauge wire should be used in the control circuit wiring.

**TABLE 7
CONTROL CIRCUIT WIRING**

Rated VA of Control Circuit Transformer	Transformer Secondary FLA @ 24V	Maximum Total Distance of Control Circuit Wiring in Feet
50	2.1	20 gauge - 45 18 gauge - 60 16 gauge - 100 14 gauge - 160 12 gauge - 250

WALL THERMOSTAT SELECTION

The wall thermostat selection is important in that it needs to be minimally 2-stage heat and 2-stage cool for applications without electric heat.

For applications with electric heat, the thermostat will need to minimally be 3-stage heat and 2-stage cool. The second bank of electric heat (when equipped) should be wired through a secondary relay for operation only in Emergency Heat Mode, at which point compressor operation should be disabled.

Refer to Figure 6 on the following page for typical thermostat connections.

Low Voltage Connection

These units use a grounded 24-volt AC low voltage circuit and require at least a 2-stage heating and a 2-stage cooling thermostat.

“R” terminal is 24 VAC hot.

“C” terminal is 24 VAC grounded.

“G” terminal is the fan input.

“Y1” terminal is the compressor part load input.

“Y2” terminal is the compressor full load input.

“O” terminal is the reversing valve input. The reversing valve must be energized for cooling mode.

“L” terminal is the check light output/compressor lockout.

This terminal is activated on high pressure switch, low pressure switch, condensate overflow, or freeze stat trip. This is a 24 VAC output.

“W1” terminal is first stage electric heat input. (If equipped.)

“E” terminal is the emergency heat input. This energizes the emergency heat relay, and should be utilized to limit the amount of electric heat with the geothermal heat pump operational to limit outlet air temperature.

“W2” terminal is the second stage electric heat input. (If equipped.)

**FIGURE 6
THERMOSTAT WIRING**

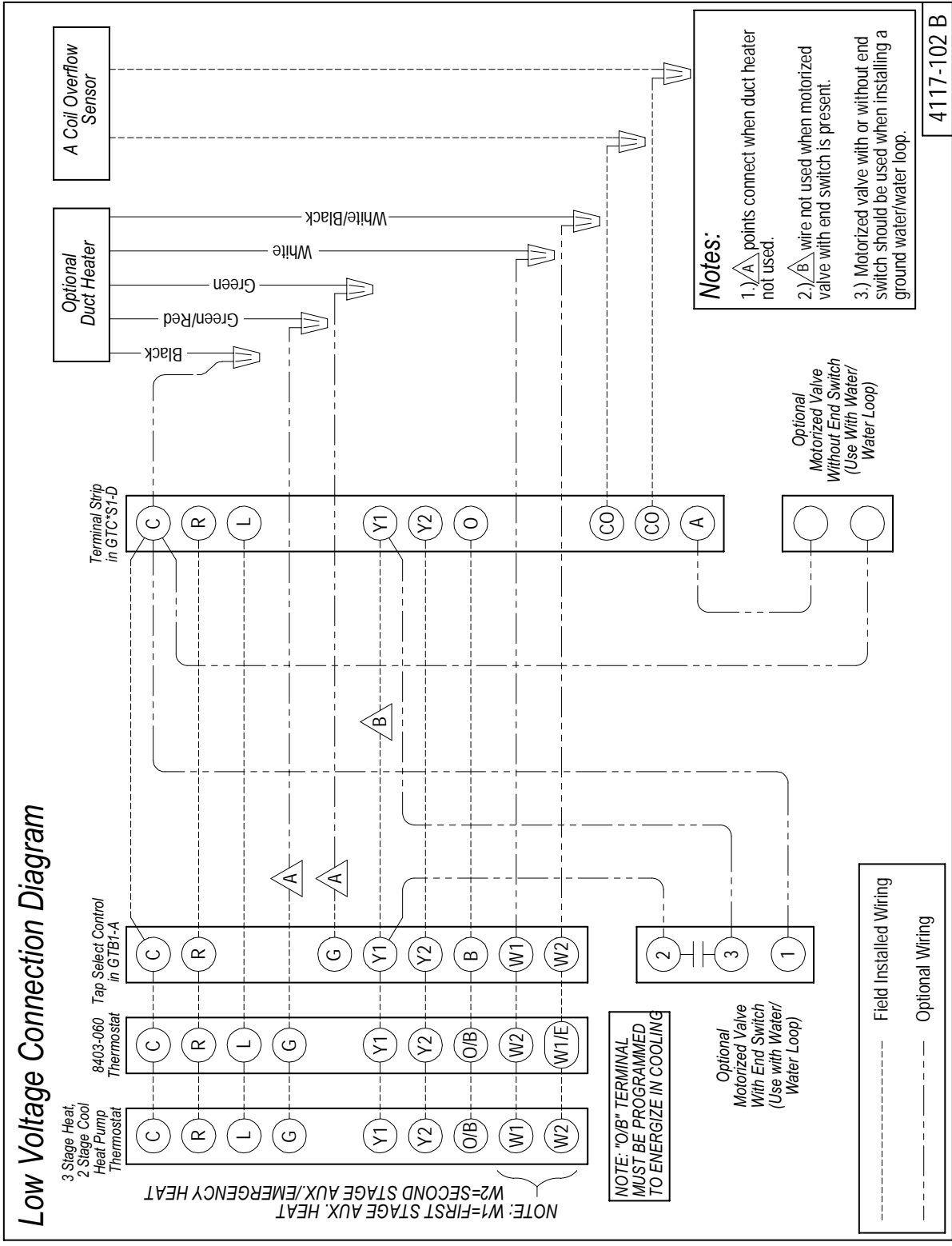

GROUND LOOP (EARTH COUPLED WATER LOOP APPLICATIONS)

NOTE:

Unit shipped from factory with 75 PSIG low pressure switch wired into control circuit and must be rewired to 55 PSIG low pressure switch for ground loop applications. This unit is designed to work on earth coupled water loop systems, however, these systems operate at entering water (without antifreeze) temperature with pressures well below the pressures normally experienced in water well systems.

THE CIRCULATION SYSTEM DESIGN

Equipment room piping design is based on years of experience with earth coupled heat pump systems. The design eliminates most causes of system failure.

The heat pump itself is rarely the cause. Most problems occur because designers and installers forget that a ground loop “earth coupled” heat pump system is NOT like a household plumbing system.

Most household water systems have more than enough water pressure either from the well pump of the municipal water system to overcome the pressure of head loss in 1/2 inch or 3/4 inch household plumbing. A closed loop earth coupled heat pump system, however, is separated from the pressure of the household supply and relies on a small, low wattage pump to circulate the water and antifreeze solution through the earth coupling, heat pump and equipment room components.

The small circulator keeps the operating costs of the system to a minimum. However, the performance of the circulator **MUST** be closely matched with the pressure of head loss of the entire system in order to provide the required flow through the heat pump. Insufficient flow through the heat exchanger is one of the most common causes of system failure. Proper system piping design and circulator selection will eliminate this problem.

**FIGURE 7
CIRCULATION SYSTEM DESIGN**

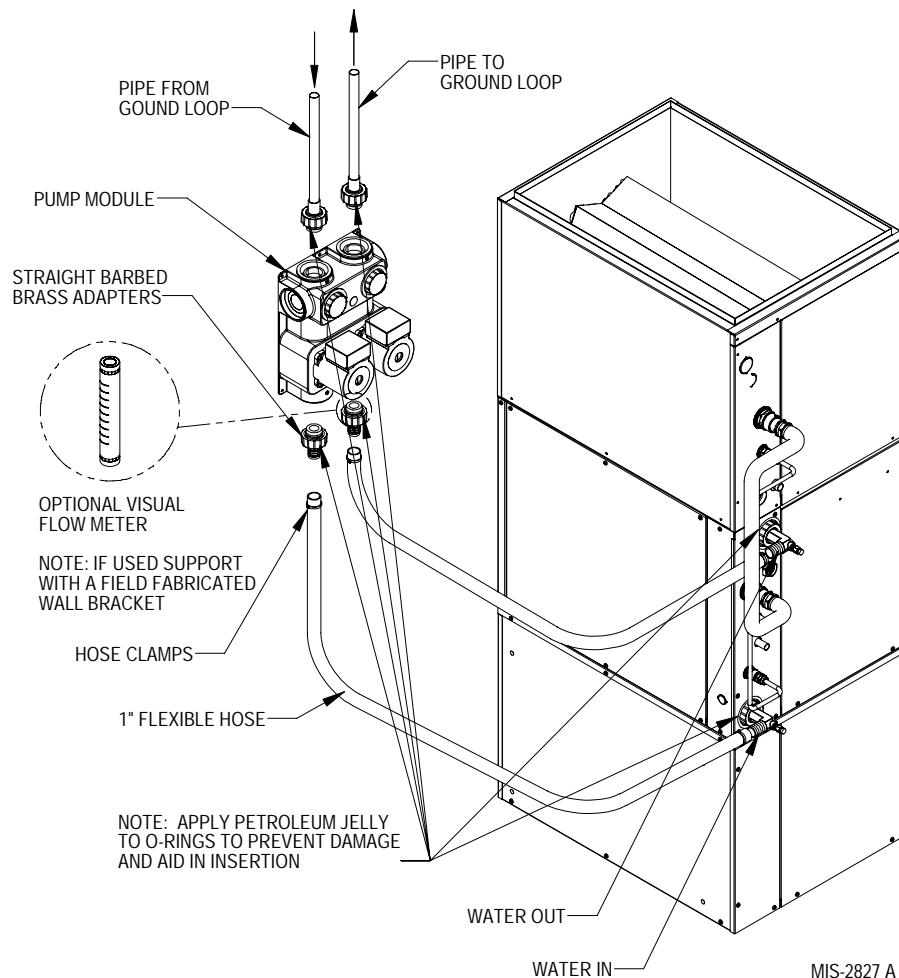

START UP PROCEDURE FOR GROUND LOOP SYSTEM

1. Be sure main power to the unit is OFF at disconnect.
2. Set thermostat system switch to OFF, fan switch to AUTO.
3. Move main power disconnect to ON. Except as required for safety while servicing, *DO NOT OPEN THE UNIT DISCONNECT SWITCH.*
4. Check system airflow for obstructions.
 - A. Move thermostat fan switch to ON. Blower runs.
 - B. Be sure all registers and grilles are open.
 - C. Move thermostat fan switch to AUTO. Blowing should stop.
5. Flush, fill and pressurize the closed loop system per IGSHPA guidelines.
6. Fully open the manual inlet and outlet valves. Start the loop pump module circulator(s) and check for proper operation. If circulator(s) are not operating, turn off power and diagnose the problem.
7. Check fluid flow using a direct reading flow meter or a single water pressure gauge, measure the pressure drop at the pressure/temperature plugs across the water coil. Compare the measurement with flow versus pressure drop table to determine the actual flow rate. If the flow rate is too low, recheck the selection of the loop pump module model for sufficient capacity. If the module selection is correct, there is probably trapped air or a restriction in the piping circuit.
8. Start the unit in cooling mode by moving the thermostat switch to cool. Fan should be set for AUTO.
9. Check the system refrigerant pressures against the cooling refrigerant pressure table in the installation manual for rated water flow and entering water temperatures. If the refrigerant pressures do not match, check for airflow problem then refrigeration system problem.
10. Switch the unit to the heating mode by moving the thermostat switch to heat. Fan should be set for AUTO.
11. Check the refrigerant system pressures against the heating refrigerant pressure table in installation manual. Once again, if they do not match, check for airflow problems and then refrigeration system problems.

NOTE: If a charge problem is determined (high or low):

- A. Check for possible refrigerant leaks.
- B. Recover all remaining refrigerant from unit and repair leak.
- C. Evacuate unit down to 29 inches of vacuum.
- D. Recharge the unit with refrigerant by weight. This is the only way to insure a proper charge.

FIGURE 8

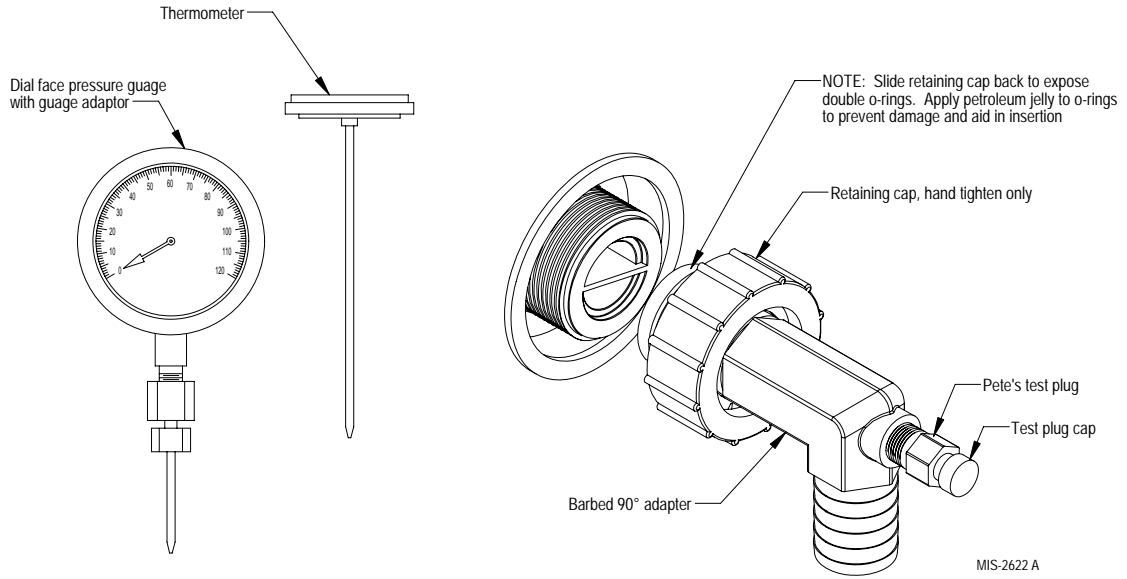

**FIGURE 9
PERFORMANCE MODEL DORFC-1 FLOW CENTER**

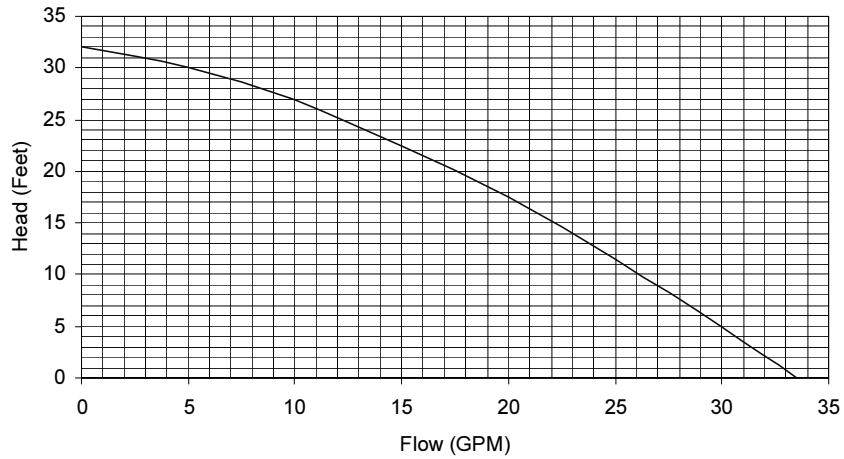

**FIGURE 10
PERFORMANCE MODEL DORFC-2 FLOW CENTER**

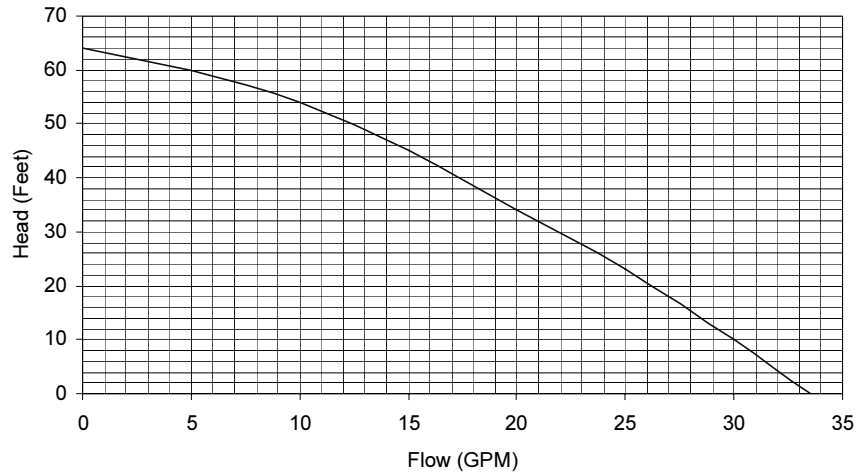

GROUND WATER (WELL SYSTEM APPLICATIONS)

NOTE:

Unit shipped from factory with 60 PSIG low pressure switch wired into control circuit for ground water applications.

WATER CONNECTIONS

It is very important that an adequate supply of clean, non-corrosive water at the proper pressure be provided before the installation is made. Insufficient water, in the heating mode for example, will cause the low pressure switch to trip, shutting down the heat pump. In assessing the capacity of the water system, it is advisable that the complete water system be evaluated to prevent possible lack of water or water pressure at various household fixtures whenever the heat pump turns on. All plumbing to and from the unit is to be installed in accordance with local plumbing codes. The use of plastic pipe, where permissible, is recommended to prevent electrolytic corrosion of the water pipe. Because of the relatively cold temperatures encountered with well water, it is strongly recommended that the water lines connecting the unit be insulated to prevent water droplets from condensing on the pipe surface.

Refer to piping, Figure 11. Slow open/close with **End Switch (2)**, 24V, provides on/off control of the water flow to the unit. Refer to the wiring diagram for correct hookup of the valve solenoid coil.

Constant Flow Valve (3) provides correct flow of water to the unit regardless of variations in water pressure. Observe the water flow direction indicated by the arrow on the side of the valve body. Following is a table showing which valve is to be installed with which heat pump.

**TABLE 8
CONSTANT FLOW VALVES**

Part No.	Min. Available Pressure PSIG	Flow Rate GPM
CFV-5	15 (1)	5
CFV-6	15 (1)	6
CFV-7	15 (1)	7
CFV-9	15 (1)	9
CFV-10	15 (1)	10

(1) The pressure drop through the constant flow valve will vary depending on the available pressure ahead of the valve. Unless minimum of 15 psig is available **immediately** ahead of the valve, no water will flow.

Strainer (8) installed upstream of **water coil inlet** to collect foreign material which would clog the flow valve orifice.

The figure shows the use of **shutoff valves (4)** and **(5)**, on the in and out water lines to permit isolation of the unit from the plumbing system should future service work require this. Globe valves should not be used as shutoff valves because of the excessive pressure drop inherent in the valve design. Instead use gate or ball valves as shutoffs, so as to minimize pressure drop.

Hose bib (6) and **(7)**, and tees should be included to permit acid cleaning the refrigerant-to-water coil should such cleaning be required. See WATER CORROSION.

Hose bib (1) provides access to the system to check water flow through the constant flow valve to insure adequate water flow through the unit. A water meter is used to check the water flow rate.

WELL PUMP SIZING

Strictly speaking, sizing the well pump is the responsibility of the well drilling contractor. It is important, however, that the HVAC contractor be familiar with the factors that determine what size pump will be required. Rule of thumb estimates will invariably lead to under or oversized well pumps. Undersizing the pump will result in inadequate water to the whole plumbing system, but with especially bad results to the heat pump – NO HEAT / NO COOL calls will result. Oversized pumps will short cycle and could cause premature pump motor or switch failures.

The well pump must be capable of supplying enough water and at an adequate pressure to meet competing demands of water fixtures. The well pump must be sized in such a way that three requirements are met:

1. Adequate flow rate in GPM.
2. Adequate pressure at the fixture.
3. Able to meet the above from the depth of the well-feet of lift.

The pressure requirements put on the pump are directly affected by the diameter of pipe being used, as well as, by the water flow rate through the pipe. The worksheet included in Manual 2100-078 should guarantee that the well pump has enough capacity. It should also ensure that

the piping is not undersized, which would create too much pressure due to friction loss. High pressure losses due to undersized pipe will reduce efficiency and require larger pumps and could also create water noise problems.

FIGURE 11
WATER CONNECTION COMPONENTS

NOTE:

Shown with Optional Top Kit for Remote Condenser Applications

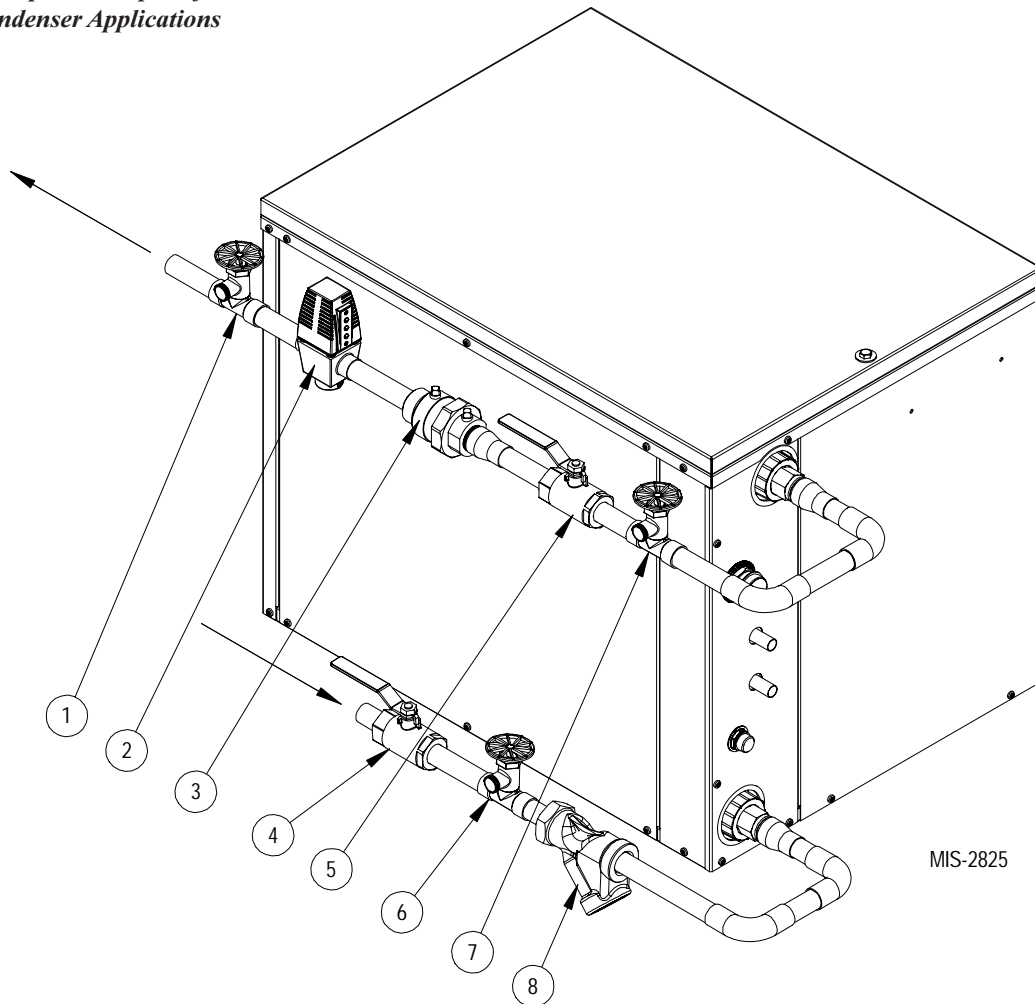

See descriptions for these reference numbers on Page 26.

SYSTEM START UP PROCEDURE FOR GROUND WATER APPLICATIONS

1. Be sure main power to the unit is OFF at disconnect.
2. Set thermostat system switch to OFF, fan switch to AUTO.
3. Move main power disconnect to ON. Except as required for safety while servicing – *DO NOT OPEN THE UNIT DISCONNECT SWITCH.*
4. Check system airflow for obstructions.
 - A. Move thermostat fan switch to ON. Blower runs.
 - B. Be sure all registers and grilles are open.
 - C. Move thermostat fan switch to AUTO. Blower should stop.
5. Fully open the manual inlet and outlet valves.
6. Check water flow.
 - A. Connect a water flow meter to the drain cock between the constant flow valve and the solenoid valve. Run a hose from the flow meter to a drain or sink. Open the drain cock.
 - B. Check the water flow rate through constant flow valve to be sure it is the same as the unit is rated for. (Example: 6 GPM for a GTC36S1.)
 - C. When water flow is okay, close drain cock and remove the water flow meter. The unit is now ready to start.
7. Start the unit in cooling mode by moving the thermostat switch to cool. Fan should be set for AUTO.
 - A. Check to see the solenoid valve opened.
8. Check the system refrigerant pressures against the cooling refrigerant pressure table in the installation manual for rated water flow and entering water temperatures. If the refrigerant pressures do not match, check for airflow problem and then refrigeration system problem.
9. Switch the unit to the heat mode by moving the thermostat switch to heat. Fan should be set for AUTO.
 - A. Check to see the solenoid valve opened again.
10. Check the refrigerant system pressures against the heating refrigerant pressure table in installation manual. Once again, if they do not match, check for airflow problems and then refrigeration system problems.

NOTE: If a charge problem is determined (high or low):

- A. Check for possible refrigerant loss.
- B. Discharge all remaining refrigerant from unit.
- C. Evacuate unit down to 29 inches of vacuum.
- D. Recharge the unit with refrigerant by weight. This is the only way to insure proper charge.

WATER CORROSION

Two concerns will immediately come to light when considering a water source heat pump, whether for ground water or for a ground loop application: Will there be enough water? And, how will the water quality affect the system?

Water quantity is an important consideration and one which is easily determined. The well driller must perform a pump down test on the well according to methods described by the National Well Water Association. This test, if performed correctly, will provide information on the rate of flow and on the capacity of the well. It is important to consider the overall capacity of the well when thinking about a water source heat pump because the heat pump may be required to run for extended periods of time.

The second concern, about water quality, is equally important. Generally speaking, if the water is not offensive for drinking purposes, it should pose no problem for the heat pump. The well driller or local water softening company can perform tests which will determine the chemical properties of the well water.

Water quality problems will show up in the heat pump in one or more of the following ways:

1. Decrease in water flow through the unit.
2. Decreased heat transfer of the water coil (entering to leaving water temperature difference is less).

There are four main water quality problems associated with ground water. These are:

1. **Biological Growth.** This is the growth of microscopic organisms in the water and will show up as a slimy deposit throughout the water system. Shock treatment of the well is usually required and this is best left up to the well driller. The treatment consists of injecting chlorine into the well casing and flushing the system until all growth is removed.
2. **Suspended Particles in the Water.** Filtering will usually remove most suspended particles (fine sand, small gravel) from the water. The problem with suspended particles in the water is that it will erode metal parts, pumps, heat transfer coils, etc. So long as the filter is cleaned and periodically maintained, suspended particles should pose no serious problem. Consult with your well driller.
3. **Corrosion of Metal.** Corrosion of metal parts results from either highly corrosive water (acid water, generally not the case with ground water) or galvanic reaction between dissimilar metals in the presence of water. By using plastic plumbing or dielectric unions, galvanic reaction is eliminated. The use of corrosion resistant materials such as the Cupronickel coil through the water system will reduce corrosion problems significantly.

4. **Scale Formation.** Of all the water problems, the formation of scale by ground water is by far the most common. Usually this scale is due to the formation of calcium carbonate but magnesium carbonate or calcium sulfate may also be present. Carbon dioxide gas (CO₂), the carbonate of calcium and magnesium carbonate, is very soluble in water. It will remain dissolved in the water until some outside factor upsets the balance. This outside influence may be a large change in water temperature or pressure. When this happens, enough carbon dioxide gas combines with dissolved calcium or magnesium in the water and falls out of solution until a new balance is reached. The change in temperature that this heat pump produces is usually not high enough to cause the dissolved gas to fall out of solution. Likewise, if pressure drops are kept to a reasonable level, no precipitation of carbon dioxide should occur.

REMEDIES OF WATER PROBLEMS

Water Treatment. Water treatment can usually be economically justified for water loop systems. However, because of the large amounts of water involved with a ground water system, water treatment is generally too expensive.

Acid Cleaning the Water Coil or Heat Pump Recovery Unit. If scaling of the coil is strongly suspected, the coil can be cleaned up with a solution of Phosphoric Acid (food grade acid). Follow the manufacturer's directions for mixing, use, etc. Refer to the "Cleaning Water Coil", Figure 12. The acid solution can be introduced into the heat pump coil through the hose bib A. Be sure the isolation valves are closed to prevent contamination of the rest of the system by the coil. The acid should be pumped from a bucket into the hose bib and returned to the bucket through the other hose bib B. Follow the manufacturer's directions for the product used as to how long the solution is to be circulated, but it is usually circulated for a period of several hours.

LAKE AND POND INSTALLATIONS

Lakes and ponds can provide a low cost source of water for heating and cooling with a ground water heat pump. Direct usage of the water without some filtration is not recommended as algae and turbid water can foul the water to refrigerant heat exchanger. Instead, there have been very good results using a dry well dug next to the water line or edge. Normal procedure in installing a dry well is to backhoe a 15 to 20 foot hole adjacent to the body of water (set backhoe as close to the water's edge as possible). Once excavated, a perforated plastic casing should be installed with gravel backfill placed around the casing. The gravel bed should provide adequate filtration of the water to allow good performance of the ground water heat pump.

The following is a list of recommendations to follow when installing this type of system:

- A. A lake or pond should be at least 1 acre (40,000 square feet) in surface area for each 50,000 BTUs of ground water heat pump capacity or have 2 times the cubic feet size of the dwelling that you are trying to heat (includes basement if heated).
- B. The average water depth should be at least 4 feet and there should be an area where the water depth is at least 12 to 15 feet deep.

**FIGURE 12
CLEANING WATER COIL**

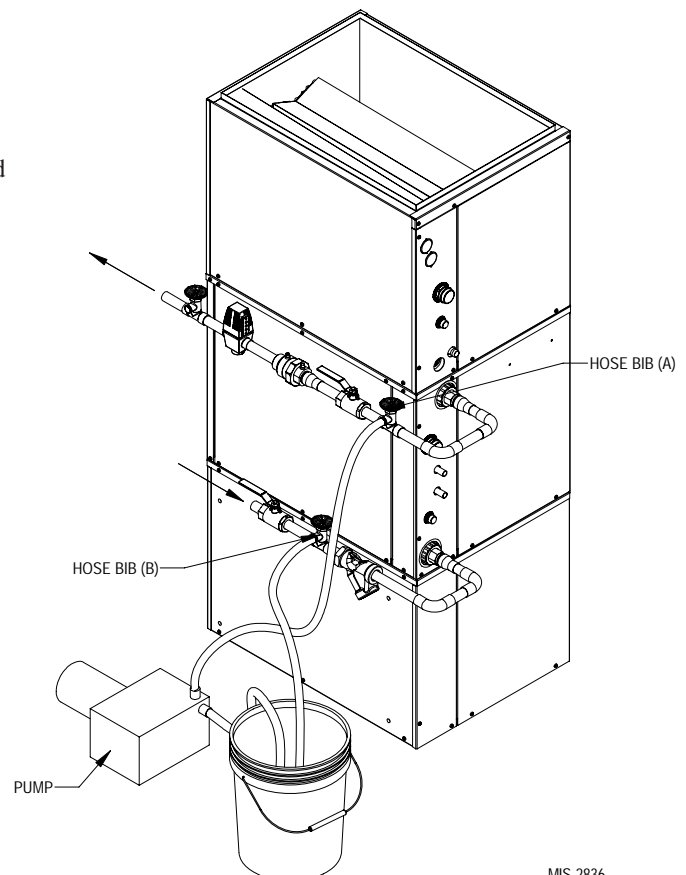

MS-2836

- C. If possible, use a submersible pump suspended in the dry well casing. Jet pumps and other types of suction pumps normally consume more electrical energy than similarly sized submersible pumps. Pipe the unit the same as a water well system.
- D. Size the pump to provide necessary GPM for the ground water heat pump. A 12 GPM or greater water flow rate is required on all models when used on this type system.
- E. A pressure tank should be installed in dwelling to be heated adjacent to the ground water heat pump. A pressure switch should be installed at the tank for pump control.
- F. All plumbing should be carefully sized to compensate for friction losses, etc., particularly if the pond or lake is over 200 feet from the dwelling to be heated or cooled.
- G. Keep all water lines below low water level and below the frost line.
- H. Most installers use 4-inch field tile (rigid plastic or corrugated) for water return to the lake or pond.
- I. The drain line discharge should be located at least 100 feet from the dry well location.

- J. The drain line should be installed with a slope of 2 inches per 10 feet of run to provide complete drainage of the line when the ground water heat pump is not operating. This gradient should also help prevent freezing of the discharge where the pipe terminates above the frost line.
- K. Locate the discharge high enough above high water level so the water will not back up and freeze inside the drain pipe.
- L. Where the local conditions prevent the use of a gravity drainage system to a lake or pond, you can instead run standard plastic piping out into the pond below the frost and low water level.

	WARNING
Thin ice may result in the vicinity of the discharge line.	

For complete information on water well systems and lake and pond applications, refer to Manual 2100-078 available from your distributor.

**FIGURE 13
LAKE OR POND INSTALLATION**

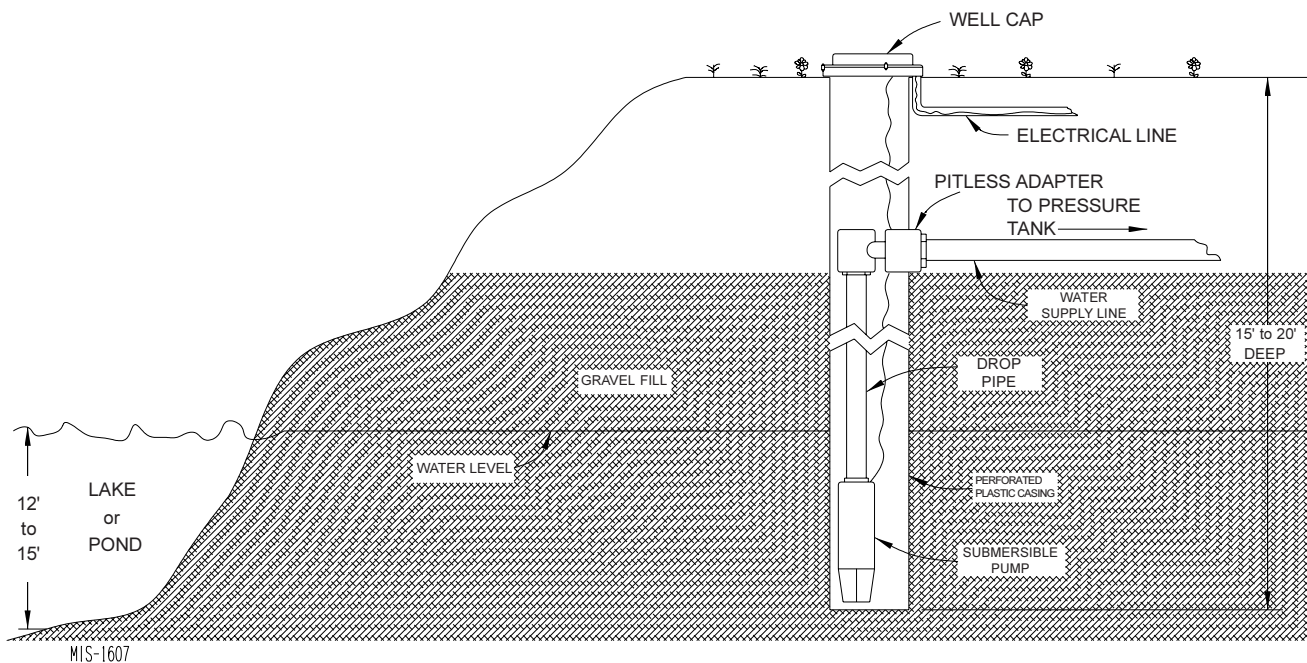

DESUPERHEATER

DESCRIPTION

The system is designed to heat domestic water using heat recovered from a water source unit's hot discharge gas.

LOCATION

Because of potential damage from freezing or condensation, the unit must be located in a conditioned space, therefore the unit must be installed indoors.

Locate the storage tank as close to the geothermal heat pump and pump module as the installation permits. Keep in mind that water lines should be a maximum of 25 feet long measured one way. Also, the vertical lift should not exceed 20 feet. This is to keep pressure and heat losses to a minimum.

ELECTRICAL CONNECTION

The Desuperheater:

The desuperheater logic control with the remote thermal sensors are built already hard-wired into the unit control panel. 208/230-60-1 power for the desuperheater pump is supplied with the same power as the compressor. The 24 volt signals needed are also tied in with the compressor call signals.



INSTALLATION PROCEDURE – GENERAL

Before beginning the installation, turn off all power supplies to the water heater and unit, and shut off the main water supply line.

TWO TANK – In order to realize the maximum energy savings from the heat recovery system, it is recommended that a second water storage tank be installed in addition to the main hot water heater. Fossil fuel fired water heaters must be a two-tank installation.

Tanks specifically intended for hot water storage are available from water heater manufacturers (solar hot water storage tanks). A well insulated electric water heater without the electric heating elements will also make a suitable storage tank.

The size of storage tank should be as large as space and economy permit but in no event should it be less than one-half of the daily water requirements for the occupants. As a guide in estimating the daily family water requirements, The Department of Energy recommends a figure of 16.07 gallons of hot water per day per individual. For example, a family of four would require 64.3 gallons per day (4 x 16.07).

ONE TANK – The single hot water tank may be a new hot water heater (sized to 100% of daily water requirements) or the existing water heater in the case of a retrofit installation. The existing water heater should be drained and flushed to remove *all* loose sediment. This sediment could damage the circulating pump. The bottom heating element should be disconnected.

NOTE: Make sure water heater thermostats are set below 125° on One Tank Unit.

WATER PIPING – All water piping must adhere to all state and local codes. Refer to piping diagrams for recommended one and two tank installations. Piping connections are 1/2 inch nominal copper plumbing.

A cleanable “Y” type strainer should also be included to collect any sediment.

OPERATION OF THE HEAT RECOVERY UNIT

The pump module is a very simple device containing basic controls and a circulating pump. Heat is transferred from the hot refrigerant (discharge gas) to the cool water.

The operation of the Desuperheater Pump Module is controlled first by the operation of the Geothermal Heat Pump and secondly by internal controls within the Pump Module. A low voltage signal from Thermostat “Y” is connected to the desuperheater control board and acts as the primary on/off switch for the circulating pump.

Also connected to this board is a temperature overlimit device which shuts down the desuperheater once inlet water has exceeded 125° so the water cannot create a scald condition.

There are also two (2) thermistor sensors connected to the control board. These thermistors are measuring and controlling to ensure there is a positive heat differential across the water being circulated. When operating in Part Load Condition, there are certain conditions (Ground Loop Temperatures versus Hot Water Temperatures) that potential exists where heat could transfer from the hot water into the refrigeration system instead of the refrigeration system into the hot water. Through the control board logic, these thermistors ensure there is at least 2° positive differential between entering/leaving water temperatures and will shut down the pump accordingly.

START UP AND CHECK OUT

Be sure all *shut off* valves are open and all power supplies are on. Open a hot water faucet to permit any air to bleed from the plumbing.

NOTE: The inherent design of this pump for maximum efficiency means this pump is not self-priming. It is imperative to check that the air has been adequately bled from the system. There is a bleed-port built into the pump module that can be utilized after the system water has been fully restored. The bleed port is located directly above the pump in the GTC compressor unit.

Turn ON the air conditioning system and verify the circulating pump will operate. Feel the “Water to Unit” and “Water from Water Heater” tubes for noticeable difference in temperature. Turn OFF the system and verify that the circulating pump stops.

*NOTE: When checking the refrigerant operating pressures of the ground source heat pump. The desuperheater **must be** turned off. With the desuperheater operating a wide variance in pressures can result, giving the service technician the indication there is a charge problem when the unit is operating correctly.*

MAINTENANCE

CLEANING THE HEAT EXCHANGER – If scaling of the coil is strongly suspected, the coil can be cleaned with a solution of phosphoric acid (food grade acid). Follow the manufacturer’s directions for the proper mixing and use of cleaning agent.

**FIGURE 14
WIRING DIAGRAM**

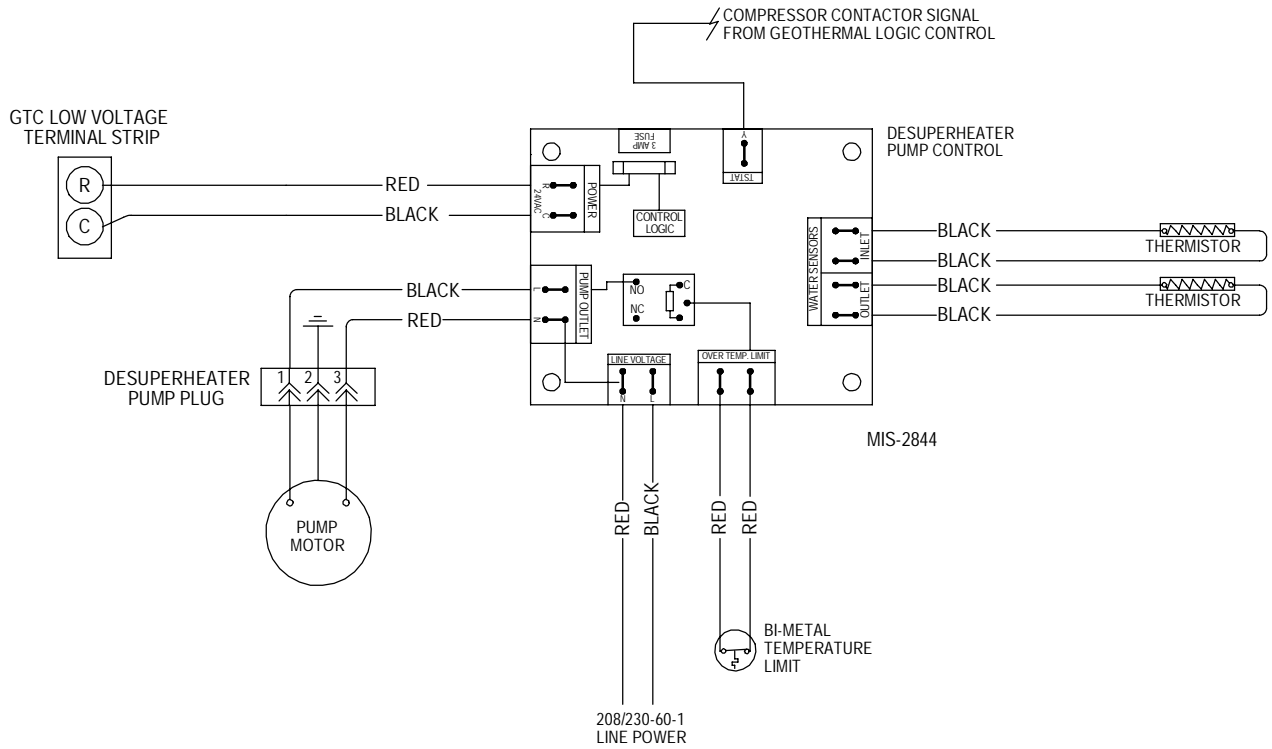
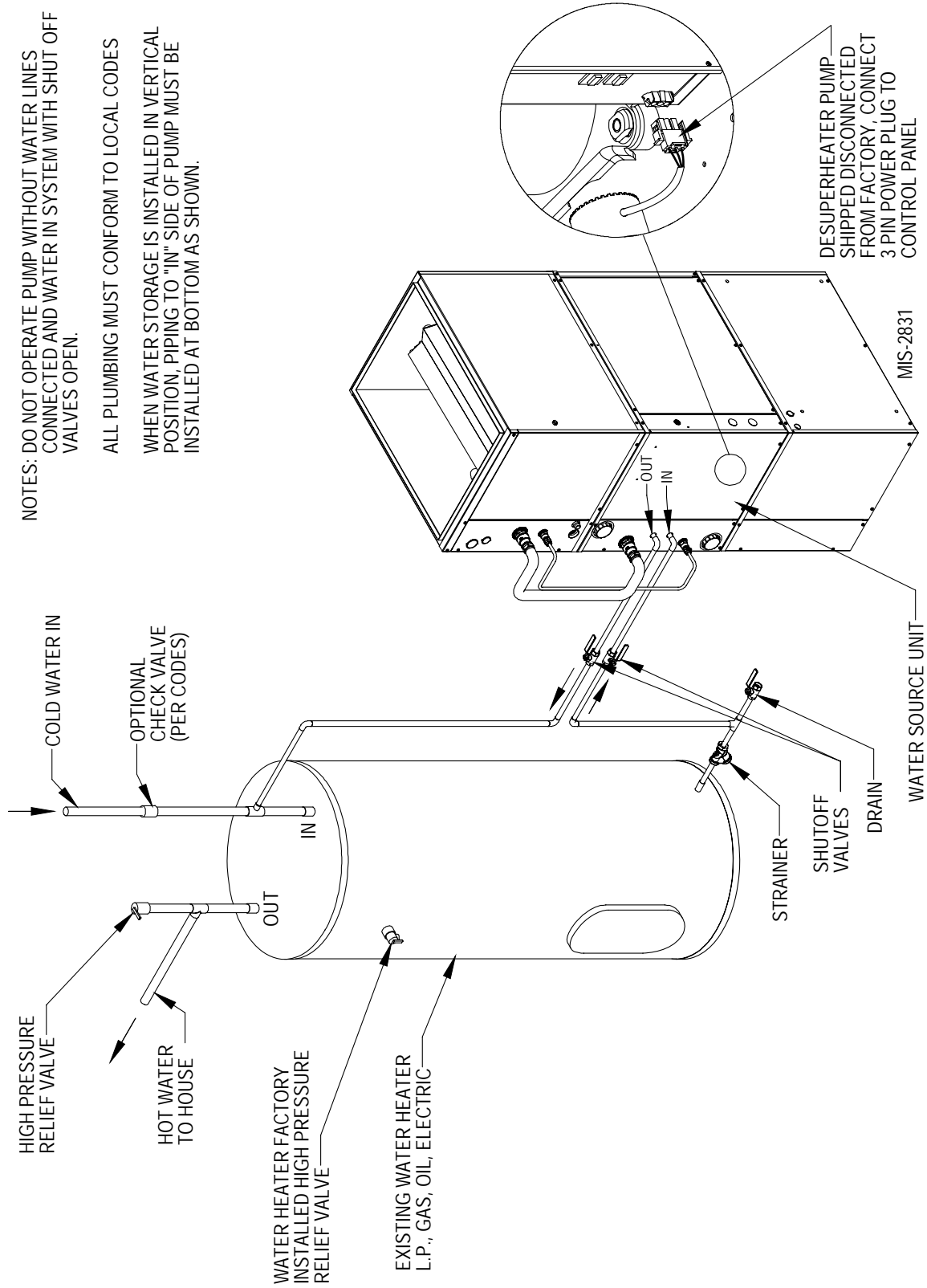

FIGURE 15A – DESUPERHEATER SINGLE TANK SYSTEM



NOTES: DO NOT OPERATE PUMP WITHOUT WATER LINES CONNECTED AND WATER IN SYSTEM WITH SHUT OFF VALVES OPEN.

ALL PLUMBING MUST CONFORM TO LOCAL CODES

WHEN WATER STORAGE IS INSTALLED IN VERTICAL POSITION, PIPING TO "IN" SIDE OF PUMP MUST BE INSTALLED AT BOTTOM AS SHOWN.

FIGURE 15B – DESUPERHEATER DUAL TANK SYSTEM

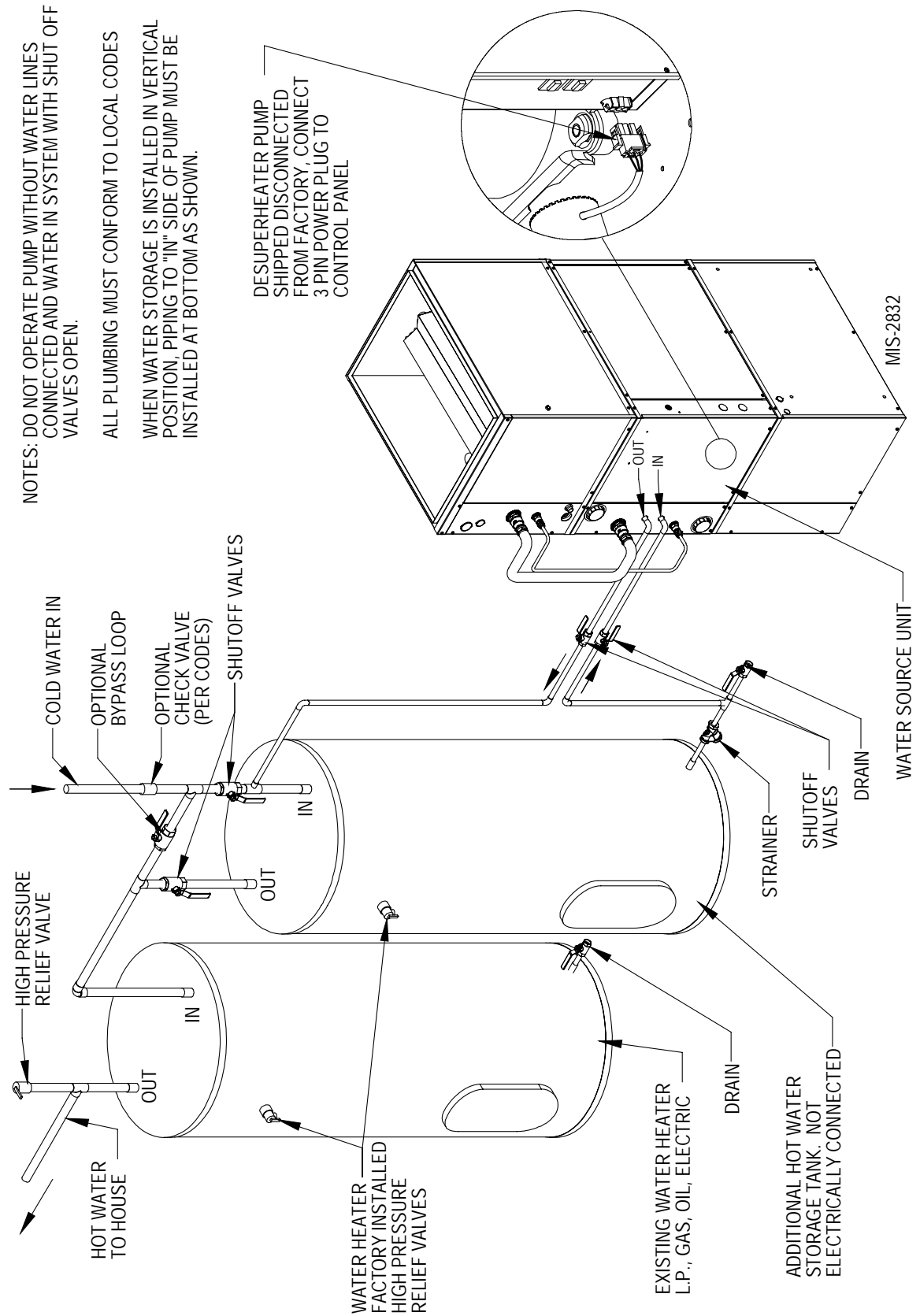

NOTES: DO NOT OPERATE PUMP WITHOUT WATER LINES CONNECTED AND WATER IN SYSTEM WITH SHUT OFF VALVES OPEN.

ALL PLUMBING MUST CONFORM TO LOCAL CODES

WHEN WATER STORAGE IS INSTALLED IN VERTICAL POSITION, PIPING TO "IN" SIDE OF PUMP MUST BE INSTALLED AT BOTTOM AS SHOWN.

DESUPERHEATER PUMP SHIPPED DISCONNECTED FROM FACTORY, CONNECT 3 PIN POWER PLUG TO CONTROL PANEL

DESUPERHEATER CONTROL BOARD SEQUENCE OF OPERATION

The desuperheating control board will make a determination whether or not to energize the pump relay inclusive on the control board.

- A. It will constantly monitor inputs from two temperature sensors, Inlet & Outlet water sensors.
- B. It will constantly monitor the Y signal.
- C. Upon acknowledgment of Y signal, and following two minutes, the control board will energize the pump relay.
- D. After 1½ minutes, based on temperature difference between Outlet & Inlet sensors, and the presence of Y signal, the following will take place:

- 1.) If temperature difference is greater than 3°F, then the control will continue to energize pump relay.
- 2.) If temperature difference is less than 3°F, then the control will de-energize the pump relay.
- 3.) The control will next wait for 10 minutes before repeating Step #1 (above).
- E. The Over Temperature Limit Switch is placed in series with the line voltage. Therefore, continuity between L of line voltage and L of pump output is forced broken when the Over Temperature Limit Switch opens (see Wiring Diagram).
- F. The 3-amp fuse is put in series with the R connection to the board. Whenever the fuse is blown, the control will lose power and consequently, the relay will disengage.

**Figure 16
THERMISTOR**

TEMPERATURE F VS RESISTANCE R OF TEMPERATURE SENSOR

F	R	F	R
53.0	19374	89.0	7507
52.0	18867	90.0	7334
53.0	18375	91.0	7165
54.0	17989	92.0	7000
55.0	17434	93.0	6840
56.0	16984	94.0	6683
57.0	16547	95.0	6531
58.0	16122	96.0	6383
59.0	15710	97.0	6239
60.0	15310	98.0	6098
61.0	14921	99.0	5961
62.0	14544	100.0	5827
63.0	14177	101.0	5697
64.0	13820	102.0	5570
65.0	13474	103.0	5446
66.0	13137	104.0	5326
67.0	12810	105.0	5208
68.0	12492	106.0	5094
69.0	12183	107.0	4982
70.0	11883	108.0	4873
71.0	11591	109.0	4767
72.0	11307	110.0	4663
73.0	11031	111.0	4562
74.0	10762	112.0	4464
75.0	10501	113.0	4367
76.0	10247	114.0	4274
77.0	10000	115.0	4182
78.0	9760	116.0	4093
79.0	9526	117.0	4006
80.0	9299	118.0	3921
81.0	9077	119.0	3838
82.0	8862	120.0	3757
83.0	8653	121.0	3678
84.0	8449	122.0	3601
85.0	8250	123.0	3526
86.0	8057	124.0	3452
87.0	7869		
88.0	7686		

SEQUENCE OF OPERATION

BLOWER

Blower functions are all controlled through 24 VAC input signals from the control thermostat and 208/230 VAC being supplied to the motor continuously.

The installer must be sure to configure the tap select control board (located in blower compartment) based upon the specific model application. By default, the tap select control (located in the blower compartment), is shipped from the factory to operate at the airflow ranges for the GTC60S1 model. Please see Wiring Diagram (Page 49) which details the required dip switch changes required between models.

NOTE 1: On a call from only “G” from the thermostat (call for manual fan), the blower will operate at a significantly reduced airflow rate to allow for air circulation and filtration, but at reduced power consumption and sound levels.

NOTE 2: There are $\pm 10\%$ adjustments that are enabled on the tap select control that will allow you to increase or decrease the air volume plus or minus 10%. Increasing the air volume may help with some slightly increased capacity and increased duct velocity if there is an air distribution issue. Decreasing the air volume will help improve latent capacity in a humid application, and will help to lower air distribution sound levels. Please see Wiring Diagram (Page 49) which details the required dip switch changes for this adjustment.

PART LOAD COOLING

When thermostat system switch is placed in COOL, it completes a circuit from “R” to “O”, energizing the reversing valve solenoid. On a call for cooling, the thermostat completes a circuit from “R” to “Y1” sending the signal to both the Tap Select Control located in the blower section and to the Geothermal Logic Control located in the compressor section. The tap select control uses the input signal versus the motor program, and the dip switch settings to determine the proper air volume rate to operate. The Geothermal Logic Control verifies that the High Pressure Switch, the Low Pressure Switch, and the Freeze Stat controls are all in the “closed” position. It then energizes the “A” terminal output to start the flow center (Ground Loop Applications) or energizes the water solenoid (Ground Water/Water Loop Applications). Following 10 seconds of the “A” terminal energization, the compressor contactor is energized.

FULL LOAD COOLING

The system should already be in Part Load Cooling operation prior to Full Load Cooling being energized. Additionally what happens, the thermostat completes a circuit from “R” to “Y2”. This sends a signal to both the staging solenoid on the side of the compressor, and sends a signal to the Blower Tap Select Control in the blower compartment to drive the blower to the proper CFM.

PART LOAD HEATING (No Electric Heat)

When thermostat system is placed in HEAT, the reversing valve solenoid is no longer energized. On a call for part load heating, the thermostat completes a call from “R” to “Y1” sending the signal to both the Tap Select Control located in the blower compartment, and to the Geothermal Logic Control located in the compressor section. The tap select control uses the input signal versus the motor program, and the dip switch settings to determine the proper air volume rate to operate. The Geothermal Logic Control verifies that the High Pressure Switch, the Low Pressure Switch, and the Freeze Stat controls are all in the “closed” position. It then energizes the “A” terminal output to start the flow center (Ground Loop Applications) or energizes the water solenoid (Ground Water/Water Loop Applications.) Following 10 seconds of the “A” terminal energization, the compressor contactor is energized.

FULL LOAD HEATING

The system should already be in Part Load Heating operation prior to Full Load Heating being energized. Additionally what happens, the thermostat completes a circuit from “R” to “Y2”. This sends a signal to both the staging solenoid on the side of the compressor, and sends a signal to the Blower Tap Select Control in the blower compartment to drive the blower to the proper CFM.

SUPPLEMENTARY ELECTRIC HEAT

The system should already be in FULL LOAD HEATING operation (above). The thermostat completes a circuit from “R” to “W2”, which energizes the first bank of electric heat.

GEOHERMAL LOGIC CONTROL

If the controller operates in normal mode, the green Status LED blinks. This indicates that 24 volt power is applied to the board and the controller is running in normal operation.

On initial power up and call for compressor operation, a 5-minute delay + a random start delay of 0 to 60-second is applied. After the random delay, the compressor relay is energized (Terminals CC & CCG). When the “Y” input opens the compressor de-energizes.

Water Solenoid – When “Y” signal is sent to Geothermal Logic Control, the water solenoid output “A” terminal will energize 10 seconds prior to “CC” output that starts compressor.

Anti-Short Cycle Timer – After compressor shutdown, or power disruption, a 5-minute timer is applied and prevents the compressor from operating.

SEQUENCE OF OPERATION

HIGH PRESSURE SWITCH

(TERMINALS HP1 & HP2) Circuit will be proved as “closed” prior to energizing “A” or “CC” terminals. If pressure switch opens, compressor will go into soft lockout mode and compressor operation will be terminated; green fault light illuminated. Logic control will then go through 5-minute delay on break + random start sequence. If no fault found on next run cycle, compressor will continue operation. If fault reoccurs, hard lockout occurs, and fault signal is sent to “L” terminal.

LOW PRESSURE SWITCH

(TERMINALS LP1 & LP2) Circuit will be proved as “closed” prior to energizing “A” or “CC” terminals. The conditions of the LP terminals will then be ignored for the first 90 seconds after a demand for compressor operation. Following this 90 second period, if pressure switch opens, compressor will go into soft lockout mode and compressor operation will be terminated; orange fault light illuminated. The control board will then go through a 5-minute delay on break + random start sequence. If no fault found on next run cycle, compressor will continue operation. If fault reoccurs, hard lockout occurs, and fault signal is sent to “L” terminal.

FREEZE STAT (Optional Field Add-On Option)

(TERMINALS FS & FS2) Circuit will be proved as “closed” prior to energizing “A” or “CC” terminals. If freezestat switch opens, compressor will go into soft lockout mode and compressor operation will be terminated; red fault light illuminated. Logic control will then go through 5-minute delay on break + random start sequence. If no fault found on next run cycle, compressor will continue operation. If fault reoccurs, hard lockout occurs, and fault signal is sent to “L” terminal.

NOTE: Jumper wire is factory installed.

CONDENSATE OVERFLOW

(Terminals CO & CO₂) This input operates when the water level in the condensation pan rises and completes a signal across the terminals of the terminal block located in the indoor coil drain pan; yellow fault light illuminates. If fault clears, the logic control will go through 5-minute delay + random start. If fault reoccurs, or didn't clear the first time after 30 seconds, the control will go into hard lockout, and will energize the “L” output signal.

UNDER & OVER VOLTAGE PROTECTION

When an under or over voltage condition exists, the controller locks out the unit. When condition clears, the controller automatically releases the unit to normal operation and the compressor restarts after the random start and anti-short cycle timings are met. The under & over voltage protection starts at plus or minus 20% from nominal voltage and returns to operation at plus or minus 10% from nominal voltage. All four (4) LED fault lights will flash when an under or over voltage condition occurs. The over voltage protection can be disabled by removing the O/V jumper.

INTELLIGENT RESET

The Geothermal Logic Control has an intelligent reset feature after a safety control is activated. The controller locks out the unit for 5 minutes, at the end of this period, the controller checks to verify that all faults have been cleared. If faults have been cleared, the controller restarts the unit. If a second fault occurs, the controller will lock out the unit until the unit is manually reset by breaking “Y” signal from thermostat. The last fault will be kept in memory after a full lockout; this is only cleared by cycling the power.

ALARM OUTPUT

The “L” terminal has 24 volts applied when a hard lockout occurs. This can be used to drive a fault light or a low voltage relay.

PRESSURE SERVICE PORTS

High and low pressure service ports are installed on all units so that the system operating pressures can be observed. Pressure tables can be found later in the manual covering all models. It is imperative to match the correct pressure table to the unit by model number.

SYSTEM START-UP

- Step 1 – Close disconnect switch(es) and set the thermostat to cool and the temperature to the highest setting.
- Step 2 – Check for proper airflow across the indoor coil.
- Step 3 – Connect the service gauges and allow the unit to run for at least 10 minutes or until pressures are stable. Check pressures to the system pressure table attached to the unit service panel.
- Step 4 – Fill out Ground Source Heat Pump Performance Report.

FIGURE 17 — COMPONENT LOCATION

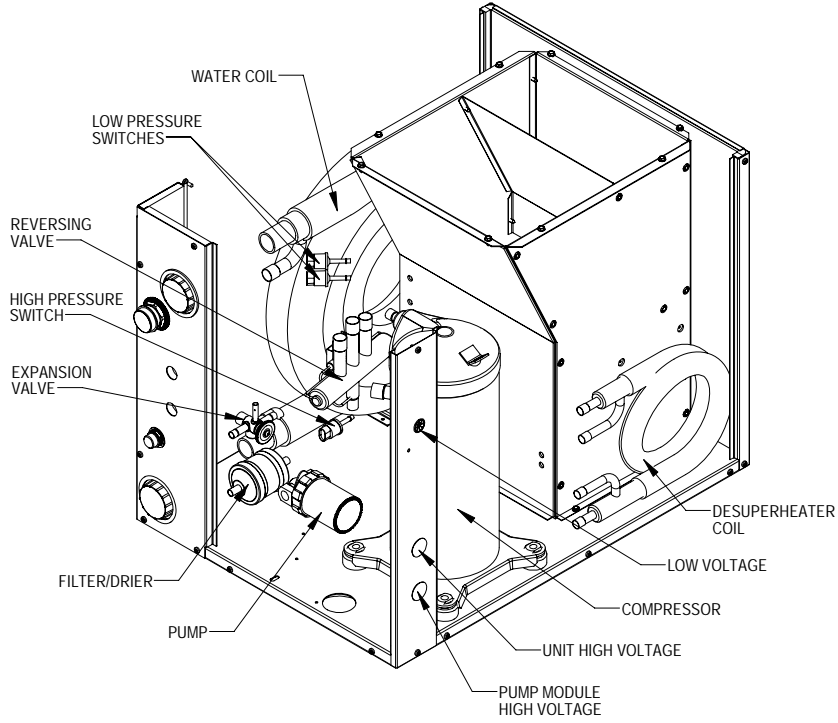

MIS-2838

FIGURE 18 — CONTROL PANEL

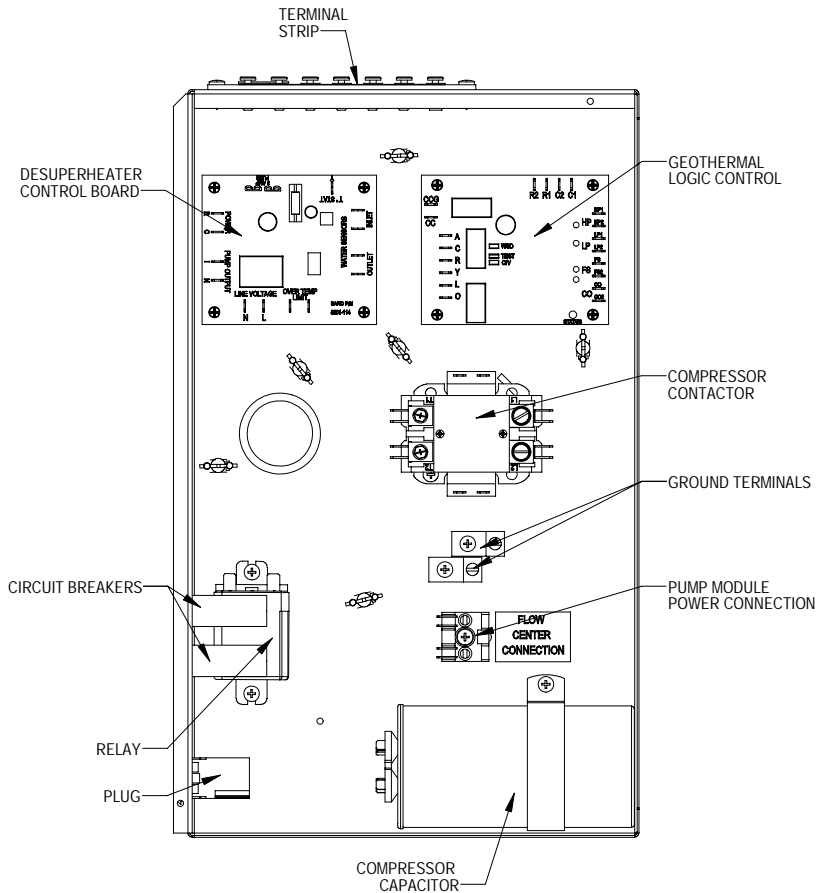

MIS-2837

FIGURE 19

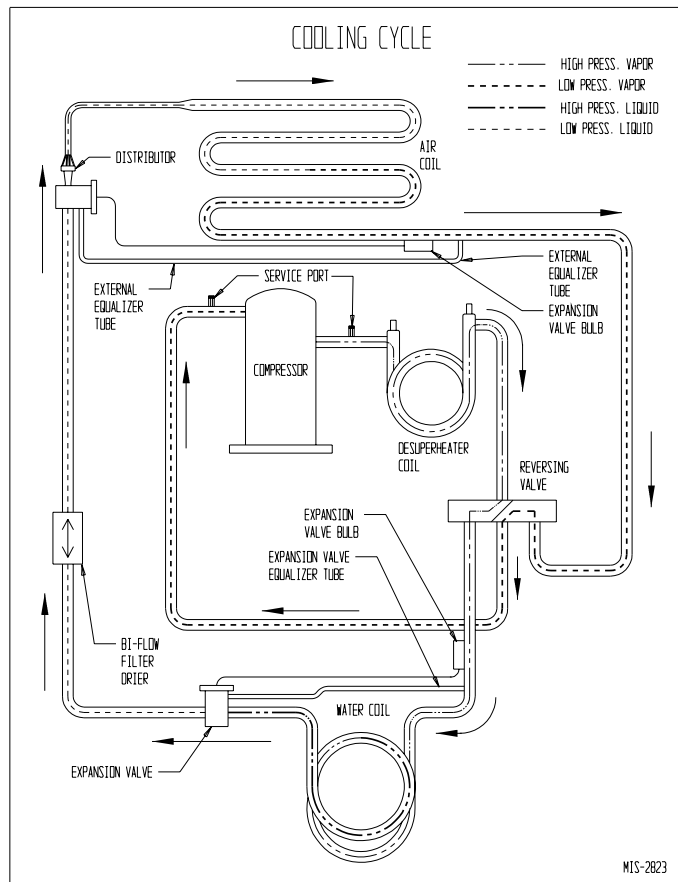
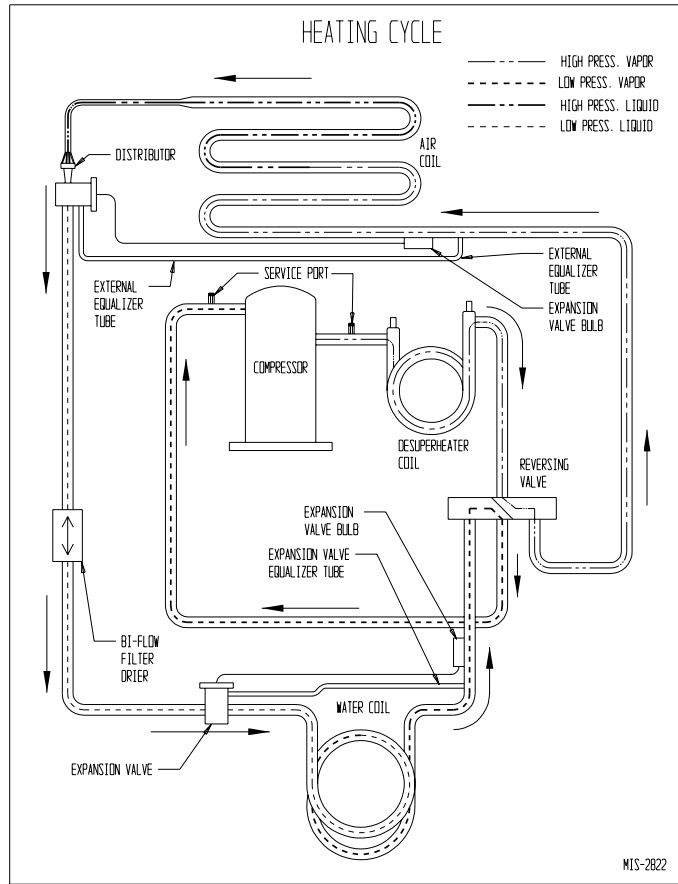

REFRIGERANT CHARGE

LINE SET INSTALLATION

CHARGE ADJUSTMENT

All supplied line sets with threaded refrigerant connections are factory evacuated and charged with R-410A refrigerant at the quantity required to optimize system performance. Refer to Figure 20 to see this charge quantity if you need to reprocess the charge due to repairing damage or replacement of a defective component.

For those using Stub Kits GTLS-SK2-1 or GTLS-SK4-1, you will first need to braze up both ends of your line set (to the point that it is sealed). Ports are provided on the GTLS-SK*-1 kits so that you can pull a vacuum on the line set and pre-charge with refrigerant before screwing on the refrigerant fittings onto the pre-charged condenser and evaporator (if using one with threaded connectors).

For charge quantity, use Figure 20 as a good general reference to the required R-410A refrigerant required based upon your line set length. Or, you can specifically measure your line set length, and add 1.4 ounces of R-410A refrigerant per 1' of line set length.

REFRIGERANT FITTING ATTACHMENT

1. Coat all mating surface, including o-rings, with R-410A refrigerant oil (Polyol Ester).
2. Attach female fittings to coil/condensing unit portion by hand-threading initially. **Be careful not to cross-thread assembly.** For the pre-manufactured 3' line set used with a vertical (stacked) configuration, the fittings should be threaded simultaneously. Again, **be careful not to cross-thread either assembly.**

3. Final torque should be achieved. Use the appropriate size wrench in conjunction with a second (backing) wrench to ensure that fittings do not spin or twist on the copper refrigerant lines. Use the following torque rates:

3/8" Lineset – 22-25 ft. lbs. (30-35 Nm)

7/8" Lineset – 44-47 ft. lbs. (60-65 Nm)

CHECKING REFRIGERANT CHARGE QUANTITY

The correct R-410A charge is shown on the unit rating plate (including adders for the various line set lengths). Reference Figure 21 to validate proper system operation. However, it is recommended that if incorrect charge is suspected, the system refrigerant be reclaimed, evacuated, and charged to nameplate charge quantity and type (including necessary charge adjustment for the installed line set length).

The nameplate charge quantity is optimized for thermal performance and efficiency throughout all modes of operation.

**FIGURE 20
PRE-CHARGED LINE SET REFRIGERANT QUANTITY**

MODEL	DESCRIPTION	R-410A CHARGE QUANTITY (Ounces)		
		3/8" Line	7/8" Line	Total
GTLS-03-1	3' Line Set	0.6	1.2	1.8
GTLS-15-1	15' Line Set	6	15	21
GTLS-25-1	25' Line Set	10	25	35
GTLS-35-1	35' Line Set	14	35	49
GTLS-50-1	50' Line Set	20	50	70

REFRIGERANT CHARGE

These units require R-410A refrigerant and Polyol Ester.

GENERAL:

1. Use separate service equipment to avoid cross contamination of oil and refrigerants.
2. Use recovery equipment rated for R-410A refrigerant.
3. Use manifold gauges rated for R-410A (800 psi/250 psi low).
4. R-410A is a binary blend of HFC-32 and HFC-125.
5. R-410A is nearly azeotropic - similar to R-22 and R-12. Although nearly azeotropic, charge with liquid refrigerant.
6. R-410A operates at 40-70% higher pressure than R-22, and systems designed for R-22 cannot withstand this higher pressure.
7. R-410A has an ozone depletion potential of zero, but must be reclaimed due to its global warming potential.
8. R-410A compressors use Polyol Ester.
9. Polyol Ester oil is hygroscopic; it will rapidly absorb moisture and strongly hold this moisture in the oil.
10. A liquid line dryer must be used - even a deep vacuum will not separate moisture from the oil.
11. Limit atmospheric exposure to 15 minutes.
12. If compressor removal is necessary, always plug compressor immediately after removal. Purge with small amount of nitrogen when inserting plugs.

TOPPING OFF SYSTEM CHARGE

If a leak has occurred in the system, reclaiming, evacuating (see criteria above), and charging to the nameplate charge is recommended.

Topping off the system charge can be done without problems. With R-410A, there are no significant changes in the refrigerant composition during multiple leaks and recharges. R-410A refrigerant is close to being an azeotropic blend (it behaves like a pure compound or single component refrigerant). The remaining refrigerant charge, in the system, may be used after leaks have occurred and then “top-off” the charge by utilizing the charging charts on the inner control panel cover as a guideline.

REMEMBER: When adding R-410A refrigerant, it must come out of the charging cylinder/tank as a liquid to avoid any fractionation, and to insure optimal system performance. Refer to instructions for the cylinder that is being utilized for proper method of liquid extraction.

SAFETY PRACTICES:

1. Never mix R-410A with other refrigerants.
2. Use gloves and safety glasses, Polyol Ester oils can be irritating to the skin, and liquid refrigerant will freeze the skin.
3. Never use air and R-410A to leak check; the mixture may become flammable.
4. Do not inhale R-410A – the vapor attacks the nervous system, creating dizziness, loss of coordination and slurred speech. Cardiac irregularities, unconsciousness and ultimate death can result from breathing this concentration.
5. Do not burn R-410A. This decomposition produces hazardous vapors. Evacuate the area if exposed.
6. Use only cylinders rated DOT4BA/4BW 400.
7. Never fill cylinders over 80% of total capacity.
8. Store cylinders in a cool area, out of direct sunlight.
9. Never heat cylinders above 125°F.
10. Never trap liquid R-410A in manifold sets, gauge lines or cylinders. R-410A expands significantly at warmer temperatures. Once a cylinder or line is full of liquid, any further rise in temperature will cause it to burst.

**FIGURE 21
PRESSURE TABLES**

Model	Return Air Temperature	Pressure	FULL LOAD COOLING — Fluid Temperature Entering Water Coil °F																
			30°F	35°F	40°F	45°F	50°F	55°F	60°F	65°F	70°F	75°F	80°F	85°F	90°F	95°F	100°F	105°F	110°F
GTC36S1	75° DB	Low Side	108	111	113	116	118	121	123	126	128	129	129	130	131	131	132	132	133
	62° WB	High Side	148	163	177	192	206	221	235	250	264	286	309	331	353	376	398	420	442
	80° DB	Low Side	116	118	121	124	126	129	132	134	137	138	138	139	140	140	141	142	142
	67° WB	High Side	152	167	182	196	211	226	241	256	271	294	317	340	362	385	408	431	454
GTC48S1	85° DB	Low Side	124	127	130	133	136	139	142	144	147	148	149	149	150	151	152	152	153
	72° WB	High Side	157	173	188	203	219	234	250	265	280	304	328	351	375	399	422	446	470
	75° DB	Low Side	109	111	113	115	117	119	121	122	124	125	127	128	129	130	131	132	133
	62° WB	High Side	148	162	176	191	205	220	234	249	263	285	306	328	349	371	392	413	435
GTC60S1	80° DB	Low Side	117	119	121	123	125	127	129	131	133	134	135	137	138	139	140	141	142
	67° WB	High Side	151	166	181	196	211	226	240	255	270	292	314	336	358	380	402	424	446
	85° DB	Low Side	126	128	130	132	134	137	139	141	143	144	145	147	148	149	151	152	153
	72° WB	High Side	157	172	187	203	218	233	249	264	279	302	325	348	371	393	416	439	462
GTC60S1	75° DB	Low Side	116	117	117	117	117	118	118	118	119	120	122	123	125	127	128	130	131
	62° WB	High Side	139	154	169	183	198	213	228	243	257	278	298	318	338	358	378	398	419
	80° DB	Low Side	124	125	125	125	126	126	126	127	127	129	130	132	134	135	137	139	140
	67° WB	High Side	143	158	173	188	203	219	234	249	264	285	305	326	347	367	388	409	429
GTC60S1	85° DB	Low Side	134	134	134	135	135	135	135	136	137	138	140	142	144	145	147	149	151
	72° WB	High Side	148	163	179	195	210	226	242	258	273	295	316	337	359	380	402	423	444

Model	Return Air Temperature	Pressure	FULL LOAD HEATING — Fluid Temperature Entering Water Coil °F																
			5°F	10°F	15°F	20°F	25°F	30°F	35°F	40°F	45°F	50°F	55°F	60°F	65°F	70°F	75°F	80°F	85°F
GTC36S1	70° DB	Low Side	45	52	59	66	72	79	86	93	99	106	117	129	140	151	162	174	185
		High Side	242	252	262	272	282	292	302	312	322	332	342	353	363	373	383	394	404
GTC48S1	70° DB	Low Side	36	44	52	60	68	76	84	92	100	108	119	129	140	150	161	171	182
		High Side	247	258	270	281	293	304	316	327	339	350	361	372	383	394	405	416	427
GTC60S1	70° DB	Low Side	38	46	54	62	70	78	86	94	102	110	118	126	134	142	150	158	166
		High Side	264	273	282	292	301	310	319	329	338	347	357	366	376	385	395	404	414

Model	Return Air Temperature	Pressure	PART LOAD COOLING — Fluid Temperature Entering Water Coil °F																
			30°F	35°F	40°F	45°F	50°F	55°F	60°F	65°F	70°F	75°F	80°F	85°F	90°F	95°F	100°F	105°F	110°F
GTC36S1	75° DB	Low Side	116	119	121	123	126	128	130	133	135	135	135	135	135	135	136	136	136
	62° WB	High Side	130	144	159	173	188	202	216	231	245	265	284	303	322	341	360	379	398
	80° DB	Low Side	124	127	129	132	134	137	139	142	144	144	145	145	145	145	145	145	145
	67° WB	High Side	133	148	163	177	192	207	222	237	252	271	291	310	330	349	369	389	408
GTC48S1	85° DB	Low Side	134	136	139	142	144	147	150	153	155	155	155	156	156	156	156	156	156
	72° WB	High Side	138	153	168	184	199	214	230	245	261	281	301	321	341	362	382	402	422
	75° DB	Low Side	119	121	123	125	127	129	132	134	136	137	137	138	139	140	141	142	143
	62° WB	High Side	131	146	160	174	189	203	217	231	246	266	287	308	328	349	370	390	411
GTC60S1	80° DB	Low Side	128	130	132	134	136	139	141	143	145	146	147	148	149	150	151	152	153
	67° WB	High Side	135	149	164	179	193	208	223	237	252	273	294	316	337	358	379	400	421
	85° DB	Low Side	137	140	142	144	147	149	151	154	156	157	158	159	160	161	162	163	164
	72° WB	High Side	139	155	170	185	200	215	230	246	261	283	305	327	348	370	392	414	436
GTC60S1	75° DB	Low Side	127	127	127	127	128	128	128	129	129	130	131	131	132	133	134	134	135
	62° WB	High Side	122	137	152	167	182	197	212	227	242	262	282	302	322	342	362	382	402
	80° DB	Low Side	135	136	136	136	137	137	137	138	138	139	140	141	141	142	143	144	145
	67° WB	High Side	125	141	156	171	187	202	217	233	248	269	289	310	330	351	371	392	412
GTC60S1	70° DB	Low Side	145	146	146	147	147	147	148	148	148	149	150	151	152	153	154	155	156
		High Side	130	146	161	177	193	209	225	241	257	278	299	320	342	363	384	405	426

Model	Return Air Temperature	Pressure	PART LOAD HEATING — Fluid Temperature Entering Water Coil °F																
			5°F	10°F	15°F	20°F	25°F	30°F	35°F	40°F	45°F	50°F	55°F	60°F	65°F	70°F	75°F	80°F	85°F
GTC36S1	70° DB	Low Side	23	35	46	57	68	80	91	102	111	120	131	143	154	165	176	188	199
		High Side	238	247	256	264	273	288	296	305	317	328	337	346	354	363	372	381	389
GTC48S1	70° DB	Low Side	20	31	43	54	66	77	89	100	109	117	129	140	152	163	175	186	198
		High Side	228	238	247	257	266	281	291	300	311	322	332	341	351	360	370	379	389
GTC60S1	70° DB	Low Side	27	38	48	58	68	79	89	99	109	119	129	140	150	160	170	181	191
		High Side	236	247	257	268	278	294	305	315	326	336	347	357	368	378	389	399	410

LOW SIDE PRESSURE +/- 2 PSIG
HIGH SIDE PRESSURE +/- 5 PSIG
Tables based upon rated CFM (airflow) across the evaporator coil.
If incorrect charge suspected (more than ±2 psig suction, ±5 psig liquid), it is recommended refrigerant charge be reclaimed, system evacuated and charged to serial plate quantity.

SERVICE HINTS

1. Caution owner to maintain clean air filters at all times. Also, not to needlessly close off supply and return air registers. This reduces airflow through the system, which shortens equipment service life as well as increasing operating costs.
2. Check all power fuses or circuit breakers to be sure that they are the correct rating.

UNBRAZING SYSTEM COMPONENTS

If the refrigerant charge is removed from a scroll equipped unit by bleeding the high side only, it is sometimes possible for the scrolls to seal, preventing pressure equalization through the compressor. This may leave low side shell and suction line tubing pressurized. If the brazing torch is then applied to the low side while the low side shell and suction line contains pressure, the pressurized refrigerant and oil mixture could ignite when it escapes and contacts the brazing flame. To prevent this occurrence, it is important to check both the high and low side with manifold gauges before unbrazing.

ECM MOTOR

This unit is equipped with an ECM motor. It is important that the blower motor plugs are not plugged in or unplugged while the power is on. Failure to remove power prior to unplugging or plugging in the motor could result in motor failure.



WARNING

Both the high and low side of the scroll compressor must be checked with manifold gauges before unbrazing system components. Failure to do so could cause pressurized refrigerant and oil mixture to ignite if it escapes and contacts the brazing flame causing property damage, bodily harm or death.



CAUTION

Do not plug in or unplug blower motor connectors while the power is on. Failure to do so may result in motor failure.

COMPRESSOR SOLENOID

(See Sequence of Operation on Pages 37 & 38 for function.)

A nominal 24-volt direct current coil activates the internal compressor solenoid. The input control circuit voltage must be 18 to 28 volts ac. The coil power requirement is 20 VA. The external electrical connection is made with a molded plug assembly. This plug contains a full wave rectifier to supply direct current to the unloader coil.

Compressor Solenoid Test Procedure – If it is suspected that the unloader is not working, the following methods may be used to verify operation.

1. Operate the system and measure compressor amperage. Cycle the compressor solenoid on and off at 10-second intervals. The compressor amperage should go up or down at least 25 percent.
2. If step one does not give the expected results, shut unit off. Apply 18 to 28 volts ac to the solenoid molded plug leads and listen for a click as the solenoid pulls in. Remove power and listen for another click as the solenoid returns to its original position.
3. If clicks can't be heard, shut off power and remove the control circuit molded plug from the compressor and measure the solenoid coil resistance. The resistance should be 32 to 60 ohms depending on compressor temperature.
4. Next, check the molded plug.

Voltage check: Apply control voltage to the plug wires (18 to 28 volts ac). The measured **dc** voltage at the female connectors in the plug should be around 15 to 27 vdc.

Resistance check: Measure the resistance from the end of one molded plug lead to either of the two female connectors in the plug. One of the connectors should read close to zero ohms, while the other should read infinity. Repeat with other wire. The same female connector as before should read zero, while the other connector again reads infinity. Reverse polarity on the ohmmeter leads and repeat. The female connector that read infinity previously should now read close to zero ohms.

Replace plug if either of these test methods does not show the desired results.

TROUBLESHOOTING GE ECM 2.3™ MOTORS

CAUTION:

Disconnect power from unit before removing or replacing connectors, or servicing motor. To avoid electric shock from the motor's capacitors, disconnect power and wait at least 5 minutes before opening motor.

Symptom

Motor rocks slightly when starting

Cause/Procedure

- This is normal start-up for ECM

Motor won't start

- No movement

- Check blower turns by hand
- Check power at motor
- Check low voltage (24 Vac R to C) at motor
- Check low voltage connections (G, Y, W, R, C) at motor
- Check for unseated pins in connectors on motor harness
- Test with a temporary jumper between R - G
- Check motor for tight shaft
- Perform motor/control replacement check
- **Perform Moisture Check**

- Motor rocks, but won't start

- Check for loose or compliant motor mount
- Make sure blower wheel is tight on shaft
- Perform motor/control replacement check

Motor oscillates up load & down while being tested off of blower

- It is normal for motor to oscillate with no on shaft

Motor starts, but runs erratically

- Varies up and down or intermittent

- Check line voltage for variation or "sag"
- Check low voltage connections (G, Y, W, R, C) at motor, unseated pins in motor harness connectors
- Check "Bk" for erratic CFM command (in variable-speed applications)
- Check out system controls, Thermostat
- **Perform Moisture Check**

- "Hunts" or "puffs" at high CFM (speed)

- Does removing panel or filter reduce "puffing"?
 - Reduce restriction
 - Reduce max airflow

- Stays at low CFM despite system call for cool or heat CFM

- Check low voltage (Thermostat) wires and connections
- Verify fan is not in delay mode; wait until delay complete
- "R" missing/not connected at motor
- Perform motor/control replacement check

- Stays at high CFM

- "R" missing/not connected at motor
- Is fan in delay mode? - wait until delay time complete
- Perform motor/control replacement check

- Blower won't shut off

- Current leakage from controls into G, Y or W? Check for Triac switched thermostat or solid-state relay

Excessive noise

- Air noise

- Determine if it's air noise, cabinet, duct or motor noise; interview customer, if necessary
- High static creating high blower speed?
 - Is airflow set properly?
 - Does removing filter cause blower to slow down? Check filter
 - Use low-pressure drop filter
 - Check/correct duct restrictions

Symptom

- Noisy blower or cabinet

Cause/Procedure

- Check for loose blower housing, panels, etc.
- High static creating high blower speed?
 - Check for air whistling through seams in ducts, cabinets or panels
 - Check for cabinet/duct deformation

- "Hunts" or "puffs" at high CFM (speed)

- Does removing panel or filter reduce "puffing"?
 - Reduce restriction
 - Reduce max. airflow

Evidence of Moisture

- Motor failure or malfunction has occurred and moisture is present
- Evidence of moisture present inside air mover

- Replace motor and **Perform Moisture Check**

- **Perform Moisture Check**

Do

- Check out motor, controls, wiring and connections thoroughly before replacing motor
- Orient connectors down so water can't get in
 - Install "drip loops"
- Use authorized motor and model #'s for replacement
- Keep static pressure to a minimum:
 - Recommend high efficiency, low static filters
 - Recommend keeping filters clean.
 - Design ductwork for min. static, max. comfort
 - Look for and recommend ductwork improvement, where necessary

Don't

- Automatically assume the motor is bad.
- Locate connectors above 7 and 4 o'clock positions
- Replace one motor or control model # with another (unless an authorized replacement)
- Use high pressure drop filters some have ½" H2O drop!
- Use restricted returns

- Size the equipment wisely

- Oversize system, then compensate with low airflow

- Check orientation before inserting motor connectors

- Plug in power connector backwards
- Force plugs

Moisture Check

- Connectors are oriented "down" (or as recommended by equipment manufacturer)
- Arrange harness with "drip loop" under motor
- Is condensate drain plugged?
- Check for low airflow (too much latent capacity)
- Check for undercharged condition
- Check and plug leaks in return ducts, cabinet

Comfort Check

- Check proper airflow settings
- Low static pressure for lowest noise
- Set low continuous-fan CFM
- Use humidistat and 2-speed cooling units
- Use zoning controls designed for ECM that regulate CFM
- Thermostat in bad location?

TROUBLESHOOTING GE ECM™ MOTORS CONT'D.

Replacing ECM Control Module

To replace the control module for the GE variable-speed indoor blower motor you need to take the following steps:

1. You **MUST** have the correct replacement module. The controls are factory programmed for specific operating modes. Even though they look alike, different modules may have completely different functionality.

USING THE WRONG CONTROL MODULE VOIDS ALL PRODUCT WARRANTIES AND MAY PRODUCE UNEXPECTED RESULTS.

2. Begin by removing AC power from the unit being serviced. **DO NOT WORK ON THE MOTOR WITH AC POWER APPLIED.** To avoid electric shock from the motor's capacitors, disconnect power and wait at least 5 minutes before opening motor.

3. It is not necessary to remove the motor from the blower assembly, nor the blower assembly from the unit. Unplug the two cable connectors to the motor control assembly. There are latches on each connector. **DO NOT PULL ON THE WIRES.** The plugs remove easily when properly released.

4. Locate the screws that retain to the motor control bracket to the sheet metal of the unit and remove them. Remove two (2) nuts that retain the control to the bracket and then remove two (2) nuts that retain sheet metal motor control end plate. Refer to Figure 22.

5. Disconnect the three (3) wires interior of the motor control by using your thumb and forefinger squeezing the latch tab and the opposite side of the connector plug, gently pulling the connector. **DO NOT PULL ON THE WIRES, GRIP THE PLUG ONLY.** Refer to Figure 22.

6. The control module is now completely detached from the motor. Verify with a standard ohmmeter that the resistance from each motor lead (in the motor plug just removed) to the motor shell is >100K ohms. Refer to Figure 23. (Measure to unpainted motor end plate.) If any motor lead fails this test, do not proceed to install the control module. **THE MOTOR IS DEFECTIVE AND MUST BE REPLACED.** Installing the new control module will cause it to fail also.

7. Verify that the replacement control is correct for your application. Refer to the manufacturer's authorized replacement list. **USING THE WRONG CONTROL WILL RESULT IN IMPROPER OR NO BLOWER OPERATION.** Orient the control module so that the 3-wire motor plug can be inserted into the socket in the control. Carefully insert the plug and press it into the socket until it latches. **A SLIGHT CLICK WILL BE HEARD WHEN PROPERLY INSERTED.**

8. Reverse the steps #5, 4, 3 to reconnect the motor control to the motor wires, securing the motor control cover plate, mounting the control to the bracket, and mounting the motor control bracket back into the unit. **MAKE SURE THE ORIENTATION YOU SELECT FOR REPLACING THE CONTROL ASSURES THE CONTROL'S CABLE CONNECTORS WILL BE LOCATED DOWNWARD IN THE APPLICATION SO THAT WATER CANNOT RUN DOWN THE CABLES AND INTO THE CONTROL. DO NOT OVERTIGHTEN THE BOLTS.**

9. Plug the 16-pin control plug into the motor. The plug is keyed. Make sure the connector is properly seated and latched.

10. Plug the 5-pin power connector into the motor. Even though the plug is keyed, **OBSERVE THE PROPER ORIENTATION. DO NOT FORCE THE CONNECTOR.** It plugs in very easily when properly oriented. **REVERSING THIS PLUG WILL CAUSE IMMEDIATE FAILURE OF THE CONTROL MODULE.**

11. Final installation check. Make sure the motor is installed as follows:

- Motor connectors should be oriented between the 4 o'clock and 8 o'clock positions when the control is positioned in its final location and orientation.
- Add a drip loop to the cables so that water cannot enter the motor by draining down the cables. Refer to Figure 24.

The installation is now complete. Reapply the AC power to the HVAC equipment and verify that the new motor control module is working properly. Follow the manufacturer's procedures for disposition of the old control module.

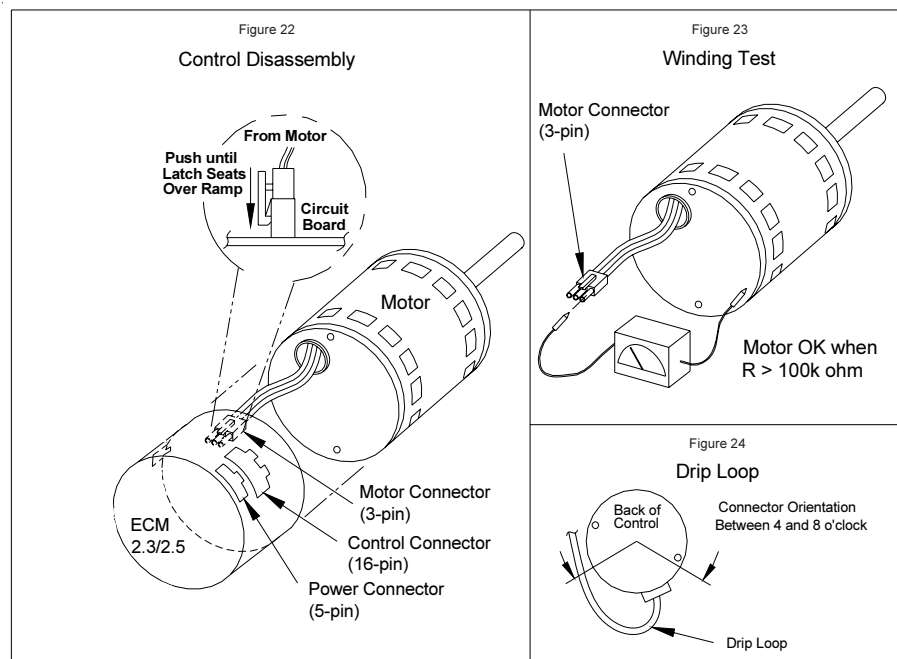

TROUBLESHOOTING GE ECM™ MOTORS CONT'D.

MODE of OPERATION	OFF	Continuous Blower	Part Load Cooling	Full Load Cooling	Part Load Heating	Full Load Heating	Full Load Heating + Electric Heat Stage #1	Emergency Heat Mode
Thermostat 24 VAC Inuput Signals	—	"G"	"G", "Y1", "O"	"G", "Y1", "Y2", "O"	"G", "Y1"	"G", "Y1", "Y2"	"G", "Y1", "Y2", "W1"	"G", "E", "W1", "W2"
Pin #1	24 VAC "C" (Common) Signal, Always Energized							
Pin #2							X	X
Pin #3	24 VAC "C" (Common) Signal, Always Energized							
Pin #4	Delay Tap Profiles, Varied Half-Wave Signals Based Upon Settings							
Pin #5	Cool Tap Select Tables, Varied Half-Wave Signals Based Upon Settings (Tonnage)							
Pin #6			X	X	X	X	X	
Pin #7	Adjustment Tap Profiles, Varied Half-Wave Signals Based Upon Settings							
Pin #8	DC Volts "-" Output in Direct Correlation to CFM							
Pin #9			X	X				
Pin #10	Future Use; Not Currently Programmed for Function							
Pin #11	Heat Tap Select Tables, Varied Half-Wave Signals Based Upon Tonnage							
Pin #12	24 VAC Hot "R" Signal, Always Energized							
Pin #13								X
Pin #14				X		X		
Pin #15		X	X	X	X	X	X	X
Pin #16	DC Volts "+" Output in Direct Correlation to CFM							

**FIGURE 25
CONTROL CONNECTOR MOTOR HALF**

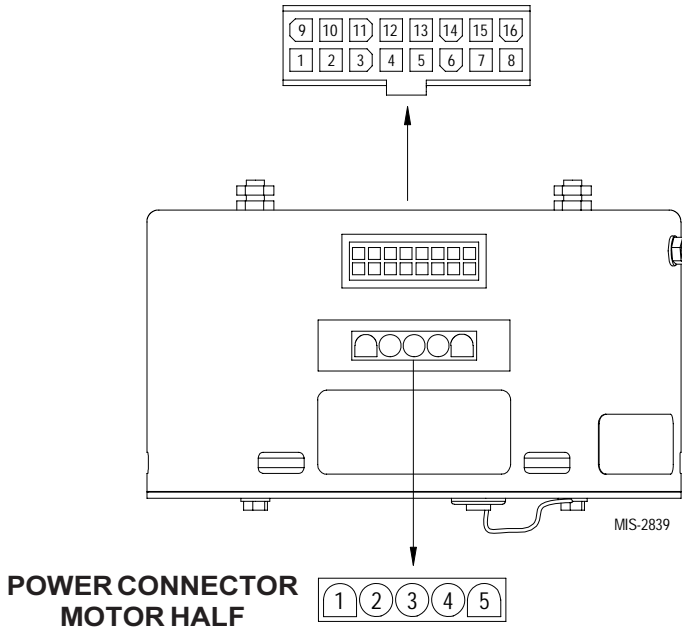

POWER CONNECTOR *	
PWB HEADER	AMP 1-350945-0
PIN	Description
1	Jumper Pin 1 to Pin 2 for 120VAC Line Input <i>Only</i> **
2	
3	Chassis Ground
4	AC Line
5	AC Line

* Suggested mating connector
Housing — AMP 350809-1
Contact — AMP 350537-1

** **WARNING** — Applying 240VAC line input with PIN 1 to PIN 2 jumper in place **will permanently damage unit!**

GROUND SOURCE HEAT PUMP PERFORMANCE REPORT

This performance check report should be filled out by installer and retained with unit.

DATE _____ TAKEN BY: _____

1. UNIT:
Mfgr _____ Model No. _____ S/N _____

THERMOSTAT:
Mfgr _____ Model No. _____ P/N _____

2. Person Reporting _____

3. Company Reporting _____

4. Installed By _____ Date Installed _____

5. User's (Owner's) Name _____
Address _____

6. Unit Location _____

WATER SYSTEM INFORMATION

7. Open Loop System (Water Well) _____ Closed Loop System _____

A. If Open Loop where is water discharged? _____

8. The following questions are for **Closed Loop systems only**

A. Closed loop system designed by _____

B. Type of antifreeze used _____ % Solution _____

C. System type: Series _____ Parallel _____

D. Pipe material _____ Nominal Size _____

E. Pipe Installed:

1. Horizontal _____ Total length of pipe _____ ft

No. pipes in trench _____ Depth bottom pipe _____ ft

2. Vertical _____ Total length of bore hole _____ ft

THE FOLLOWING INFORMATION IS NEEDED TO CHECK PERFORMANCE OF UNIT.

FLUID SIDE DATA

	Cooling	** Heating	
9. Entering fluid temperature	_____	_____	F
10. Leaving fluid temperature	_____	_____	F
11. Entering fluid pressure	_____	_____	PSIG
12. Leaving fluid pressure	_____	_____	PSIG
13. Pressure drop through coil	_____	_____	PSIG
14. Gallons per minute through the water coil	_____	_____	GPM
15. Liquid or discharge line pressure	_____	_____	PSIG
16. Suction line pressure	_____	_____	PSIG
17. Voltage at compressor (unit running)	_____	_____	V
18. Amperage draw at line side of contactor	_____	_____	A
19. Amperage at compressor common terminal	_____	_____	A
20. * Suction line temperature 6" from compressor	_____	_____	F
21. * Superheat at compressor	_____	_____	F
22. * Liquid line temperature at metering device	_____	_____	F
23. * Coil subcooling	_____	_____	F

INDOOR SIDE DATA

	Cooling	** Heating	
24. Dry bulb temperature at air entering indoor coil	_____	_____	F
25. Wet bulb temperature of air entering indoor coil	_____	_____	F
26. Dry bulb temperature of air leaving indoor coil	_____	_____	F
27. Wet bulb temperature of air leaving indoor coil	_____	_____	F
28. * Supply air static pressure (packaged unit)	_____	_____	WC
29. * Return air static pressure (packaged unit)	_____	_____	WC
30. Other information about installation	_____		

** When performing a heating test insure that 2nd stage heat is not activated

* Items that are optional

