

WATER SOURCE HEAT PUMP MODELS:

INSTALLATION INSTRUCTIONS

GTB1-A	Blower Section
GTA3600UD1AA	Coil Section
GTA4860UD1AA	Coil Section
GTADP-3642-B	Coil Section
GTADP-3642-C	Coil Section
GTADP-4860-C	Coil Section
GTC36S2-ADCX	Compressor Section
GTC48S2-ADCX	Compressor Section
GTC60S2-ADCX	Compressor Section
GTC36S2-ADNX	Compressor Section
GTC48S2-ADNX	Compressor Section
GTC60S2-ADNX	Compressor Section

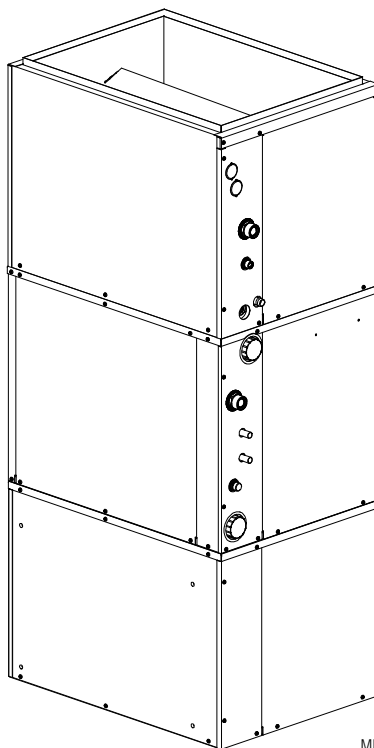

MIS-2830

**Earth Loop Fluid
Temperatures 25° - 110°
Ground Water Temperatures 45° - 75°**

BMC, Inc.
Bryan, Ohio 43506

Manufactured under the following
U.S. patent number:
8,127,566

Manual: 2100-537K
Supersedes: 2100-537J
File: Volume I, Tab 8
Date: 03-07-14

CONTENTS

Getting Other Informations and Publications.....	3
General Information Geo-Trio (GT Series)	
Water Source Nomenclature	4
Blower Conversion & Line Power Connect	15
Application and Location	
General	18
Shipping Damage.....	18
Application	18
Dual Fuel Heating / Cooling	18
Location	18
Ductwork	18
Filters	19
Condensate Drain	19
Piping Access to Unit.....	19
Wiring Instructions	
General	22
Control Circuit Wiring.....	22
Wall Thermostats & Low Voltage Connections.....	22
Ground Loop (Earth Coupled Water Loop Applications)	
Note	24
Circulation System Design	24
Start Up Procedure for Ground Loop System	25
Ground Water (Well System Applications)	
Note	27
Water Connections	27
Well Pump Sizing	27 & 28
Start Up Procedure for Ground Water System	29
Water Corrosion	29 & 30
Remedies of Water Problems.....	30
Lake and/or Pond Installations	30 & 31
Desuperheater	
Description	32
Location	32
Electrical Connection.....	32
Installation Procedure - General.....	32
Oper. of Heat Recovery Unit	33
Start Up & Checkout.....	33
Maintenance & Control Board Seq. of Operation	33 & 37

Sequence of Operation	
Blower	38
Part / Full Load Cooling.....	38
Part / Full Load Heating.....	38
Supplementary Electric Heat.....	38
Geothermal Logic Controls.....	39
High / Low Pressure Switch	39
Freeze Stat	39
Condensate Overflow	39
Under/Over Voltage Protection.....	39
Intelligent Reset.....	39
Alarm Output	39
Pressure Service Ports.....	39
System Start Up	39
Refrigerant Charge	
Line Set Installation (GTA Coil Sections).....	42
Charge Adjustment.....	42
Refrigerant Fitting Attachment.....	42
Checking Charge Quantity	42
General / GTADP Coi Sections	43
Line Set Installation (GTADP Coil Sections).....	43
General / Topping Off System / Safety Practices	44
Service	
Service Hints	47
Unbrazing System Components.....	47
Compressor Solenoid.....	47
Troubleshooting GE ECM 2.3 Motors.....	48 & 49
Troubleshooting Table	50
Power Connector Table	50
Ground Source Heat Pump	
Performance Report.....	51-52
Wiring Diagrams	53-54

Figures	
Figure 1A GTA****UD1AA Dimensions	7
Figure 1B GTADP Fossil Fuel ADP Coil Dimensions	8
Figure 1C GTB1-A Dimensions	9
Figure 1D GTC**S2-D Dimensions	10
Figure 1E Assembled Upflow/Counterflow App.	11
Figure 1F Horizontal App. Dimensions	12
Figure 2A Upflow & Counterflow Ducting Config.....	13
Figure 2B Horiz. & Counterflow Ducting Config.....	14
Figure 3 Blower Configuration	16
Figure 4 Blower Power Connections	17
Figure 5A Upflow Air Filter Applications	21
Figure 5B Counterflow Air Filter Applications	21
Figure 5C Horiz. Left Discharge Air Filter App.....	21
Figure 5D Horiz. Front Discharge App.	21
Figure 6 Thermostat Wiring	23
Figure 7 Circulation System Design	24
Figure 8 Temperature & Pressure Measurement	26
Figure 9 Perf. Model DORFC-1 Flow Ctr.	26
Figure 10 Perf. Model DORFC-2 Flow Ctr.	26
Figure 11 Water Connection Components.....	28
Figure 12 Cleaning Water Coil.....	30
Figure 13 Lake or Pond Installation	31
Figure 14 Wiring Diagram.....	34

Figure 15A Desuperheater Single Tank System	35
Figure 15B Desuperheater Dual Tank System	36
Figure 16 Thermistor	37
Figure 17 Component Location	40
Figure 18 Control Panel.....	40
Figure 19 Refrigerant Flow Diagrams.....	41
Figure 20 Coil Spacer	43
Figure 21 Pressure Tables.....	45
Figure 22 Control Disassembly.....	49
Figure 23 Winding Test.....	49
Figure 24 Drip Loop	49
Figure 25 Control Connector Motor Half.....	50
Tables	
Table 1 Indoor Blower Performance.....	5
Table 2 Flow Rates for Various Fluids.....	5
Table 3 Specifications	5
Table 4 Water Coil Pressure Drop.....	6
Table 5 Electrical Heat Specifications	19
Table 6 Filter Sizing Chart	20
Table 7 Control Circuit Wiring.....	22
Table 8 Constant Flow Valves	27
Table 9 Pre-Charged Line Set Qty	42
Quick Reference Troubleshooting Chart	46

GETTING OTHER INFORMATION AND PUBLICATIONS

These publications can help you install the air conditioner or heat pump. You can usually find these at your local library or purchase them directly from the publisher. Be sure to consult current edition of each standard.

National Electrical CodeANSI/NFPA 70

Standard for the Installation.....ANSI/NFPA 90A
of Air Conditioning and Ventilating Systems

Standard for Warm Air.....ANSI/NFPA 90B
Heating and Air Conditioning Systems

Load Calculation for ResidentialACCA Manual J
Winter and Summer Air Conditioning

Duct Design for Residential.....ACCA Manual D
Winter and Summer Air Conditioning and Equipment
Selection

Closed-Loop/Ground Source Heat PumpIGSHPA
Systems Installation Guide

Grouting Procedures for Ground-SourceIGSHPA
Heat Pump Systems

Soil and Rock Classification forIGSHPA
the Design of Ground-Coupled Heat Pump Systems

Ground Source Installation StandardsIGSHPA

Closed-Loop Geothermal SystemsIGSHPA
– Slinky Installation Guide

FOR MORE INFORMATION, CONTACT THESE PUBLISHERS:

ACCA **Air Conditioning Contractors of America**
1712 New Hampshire Avenue
Washington, DC 20009
Telephone: (202) 483-9370
Fax: (202) 234-4721

ANSI **American National Standards Institute**
11 West Street, 13th Floor
New York, NY 10036
Telephone: (212) 642-4900
Fax: (212) 302-1286

ASHRAE **American Society of Heating Refrigerating,
and Air Conditioning Engineers, Inc.**
1791 Tullie Circle, N.E.
Atlanta, GA 30329-2305
Telephone: (404) 636-8400
Fax: (404) 321-5478

NFPA **National Fire Protection Association**
Batterymarch Park
P.O. Box 9101
Quincy, MA 02269-9901
Telephone: (800) 344-3555
Fax: (617) 984-7057

IGSHPA **International Ground Source
Heat Pump Association**
490 Cordell South
Stillwater, OK 74078-8018

Geo-Trio™ GT Series Geothermal / Water Source Heat Pump Nomenclature

"A" Coil Section

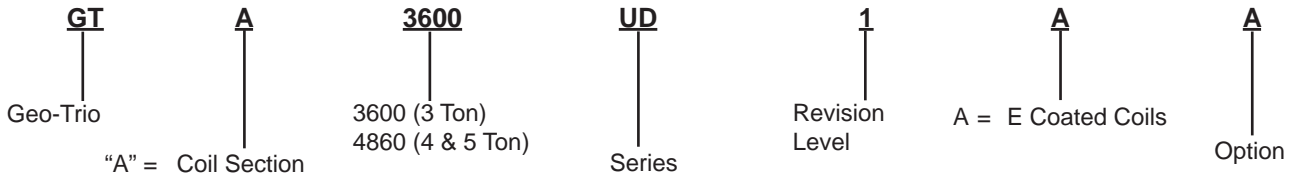

Fossil Fuel "A" Coil Section

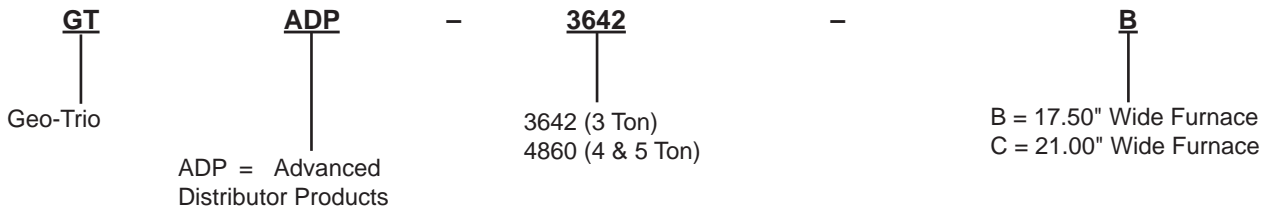

Blower Section

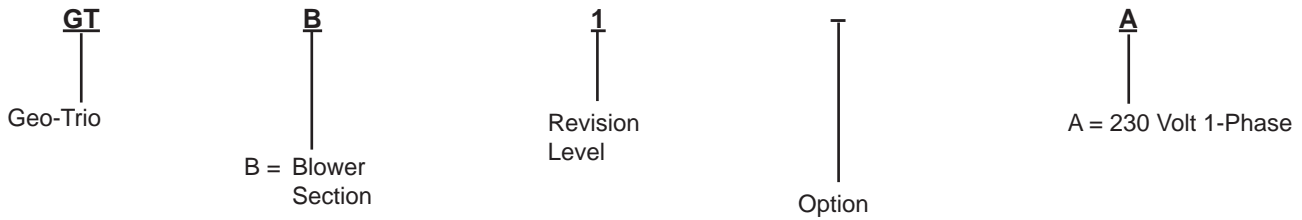

Compressor Section

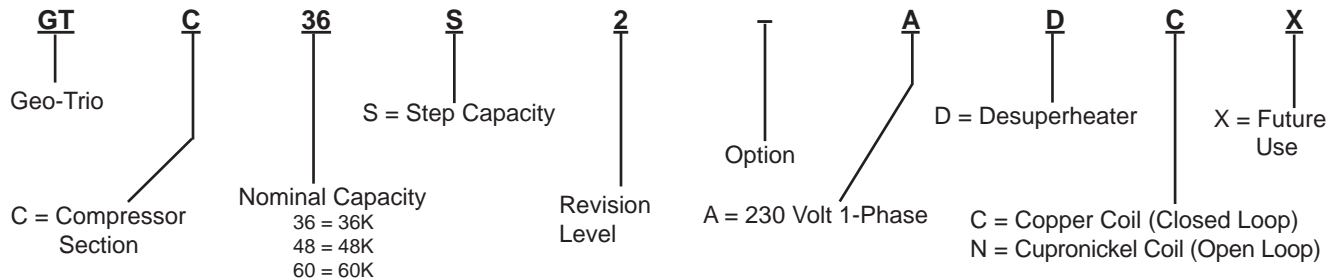

TABLE 1 — INDOOR BLOWER PERFORMANCE (RATED CFM) ①

MODEL	② Rated ESP	③ MAX ESP	④ Continuous Airflow	⑤ Mild Climate Operation in Part Load Cooling	⑥ Part Load Airflow	Full Load Airflow	⑦ Electric Heat Airflow	⑧ Minimum Air Filter Face Area Ft.2
GTC36S2	0.15	0.60	600	700	850	1200	1300	2.6
GTC48S2	0.20	0.60	750	875	1075	1500	1600	3.2
GTC60S2	0.20	0.60	900	1050	1300	1800	1800	3.6

- ① Motor will automatically step through the various airflows with thermostatic control
- ② ESP = External Static Pressure (inches of water)
- ③ Maximum allowable duct static
- ④ Continuous airflow is the CFM being circulated with manual fan operation without any additional function occurring.
- ⑤ Will occur automatically for first 5 minutes of Part Load Cooling Operation.
- ⑥ Will occur automatically after five minutes of Part Load Cooling Operation.
- ⑦ Will occur automatically with control signal input.
- ⑧ As per ASHRAE Guidelines of 500 FPM Velocities.

NOTE: All values can be changed $\pm 10\%$ via the \pm adjustment dip switches on the tap select control inclusive in the GTBI-A Blower Section (see instructions later in this manual, or on wiring diagram in blower section).

TABLE 2 — FLOW RATES FOR VARIOUS FLUIDS

APPLICATION	MODELS		
	GTC36S2	GTC48S2	GTC60S2
Ground Loop (15% Methanol, Propylene Glycol, etc.)	8	12	15
Ground Water	6	7	9
Water Loop (Cooling Tower)	9.2	12.1	14.3

TABLE 3 — SPECIFICATIONS

MODEL	GTC36S2	GTC48S2	GTC60S2
Electrical Rating (60HZ/1PH)	230/208-60-1		
Operating Voltage Range	253-197 VAC		
Minimum Circuit Ampacity	24.5	33.1	39.7
+Field Wire Size	#10	#6	#4
Ground Wire Size	#10	#10	#10
++Delay Fuse or Circuit Breaker Max.	35	50	60
COMPRESSOR			
Volts	230/208-60-1		
Rated Load Amps (230/208)	10.6 / 11.9	15.3 / 17.0	20.2 / 22.7
Branch Circuit Selection Current	15.3	21.2	25.6
Locked Rotor Amps (230/208)	82 / 82	104 / 104	153 / 153
BLOWER MOTOR			
Horsepower (ECM Motor)	3/4 Variable Speed		
Volts	230/208-60-1		
Motor Amps (Stage #2 @ Rated CFM)	3.4	4.3	4.4
FLOW CENTER (Based on DORFC-2)			
Volts	230/208-60-1		
Amps	2.14	2.14	2.14
DESUPERHEATER PUMP MOTOR			
Volts	230/208-60-1		
Amps	0.15	0.15	0.15

+75°C copper wire ++ HACR type circuit breaker

**TABLE 4
WATER COIL PRESSURE DROP**

Model GPM	GTC36S2		GTC48S2		GTC60S2	
	PSID	Ft. Hd.	PSID	Ft. Hd.	PSID	Ft. Hd.
3	0.1	0.23				
4	0.5	1.15	0.9	2.08		
5	1.2	2.77	1.4	3.23		
6	1.7	3.92	2.3	5.31		
7	2.3	5.31	3.2	7.38	2	4.61
8	3.1	7.15	4.1	9.46	2.5	5.77
9	4.1	9.46	5.1	11.77	3.2	7.38
10			6.1	14.07	3.9	9.00
11			7.1	16.38	4.7	10.84
12			8.2	18.92	5.5	12.69
13			9.4	21.69	6.4	14.76
14			10.6	24.45	7.3	16.84
15					8.1	18.69
16					9	20.76
17					9.9	22.84
18						

FIGURE 1A – GTA**UD1AA
A-COIL SECTION DIMENSIONS**

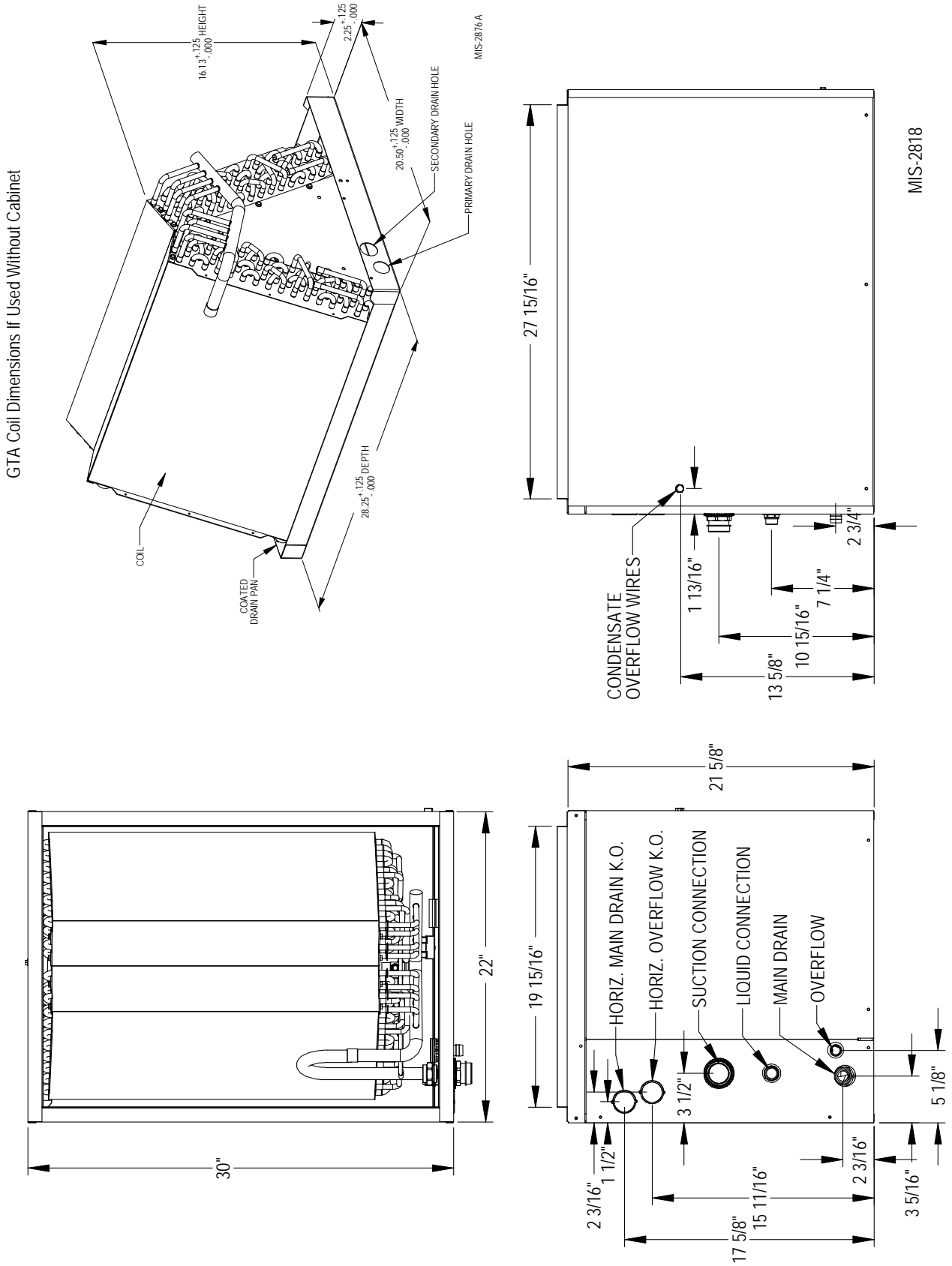
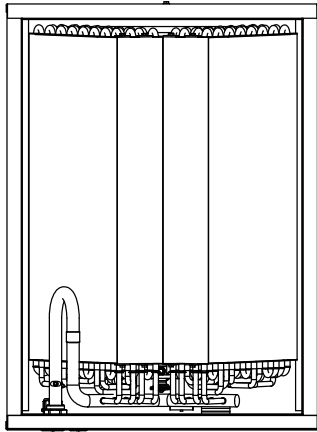
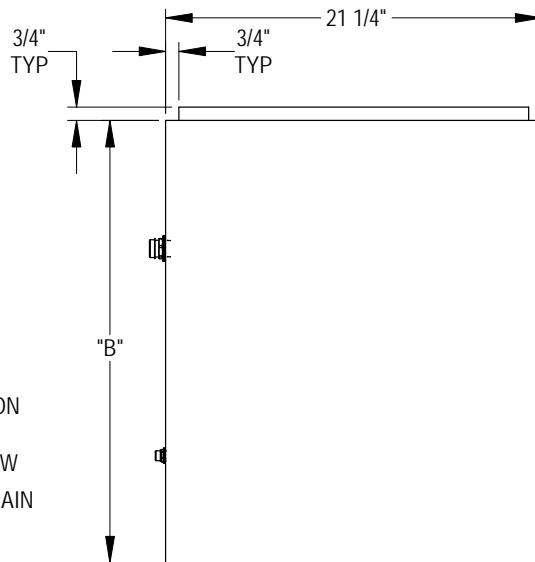
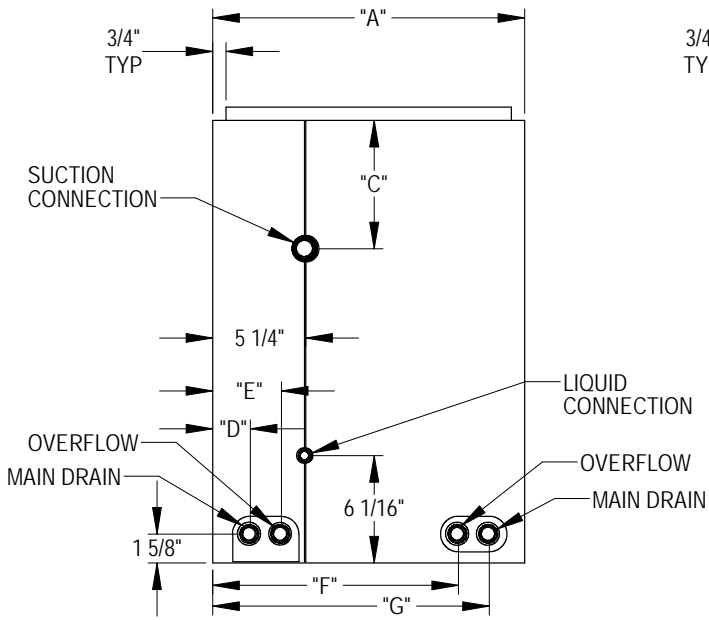

FIGURE 1B – GTADP**.*
FOSSIL FUEL ADP COIL SECTION DIMENSIONS**



DIMENSION	GTADP-3642-B	GTADP-3642-C GTADP-4860-C
"A"	17 5/8"	21 1/8"
"B"	25 1/2"	27 1/2"
"C"	7 1/4"	6 3/4"
"D"	2 1/8"	2 1/2"
"E"	3 7/8"	4 1/4"
"F"	13 7/8"	16 7/8"
"G"	15 5/8"	18 5/8"



MIS-3119

**FIGURE 1C – GTB1-A
BLOWER SECTION DIMENSIONS**

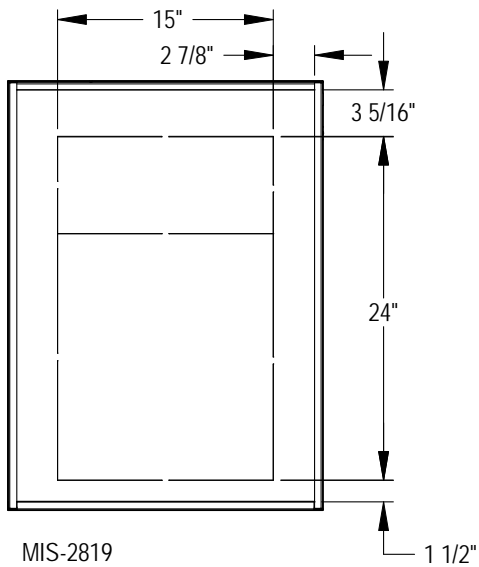
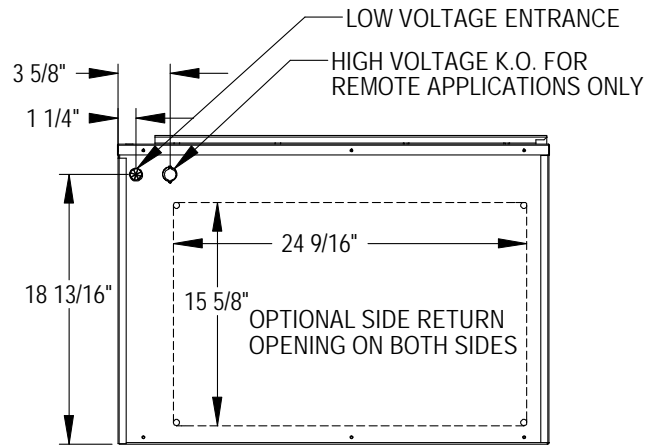
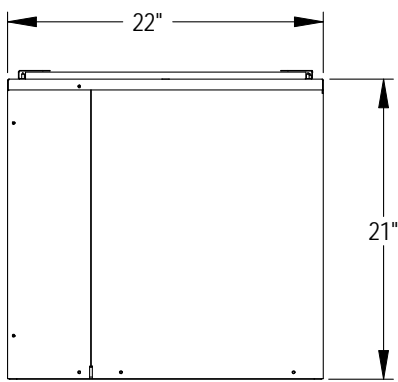
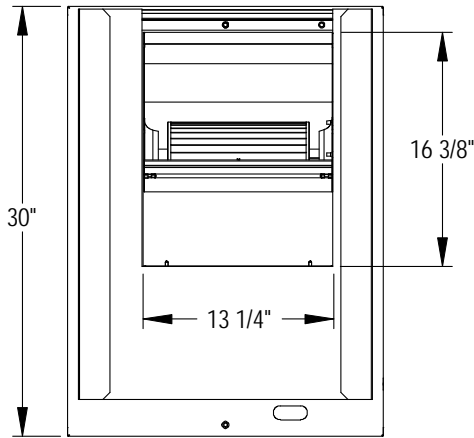

MIS-2819

FIGURE 1D – GTCS2-D
COMPRESSOR SECTION DIMENSIONS**

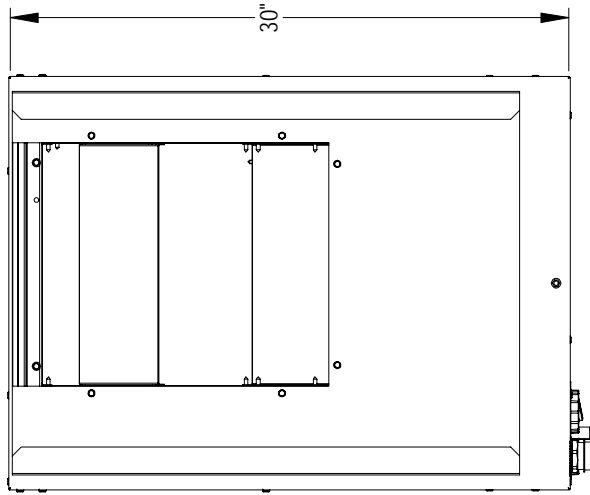

MODEL	DIM. A	DIM. B
GTC36S2	21"	4 1/8"
GTC48S2	20"	3 7/8"
GTC60S2	18 1/2"	3 3/4"

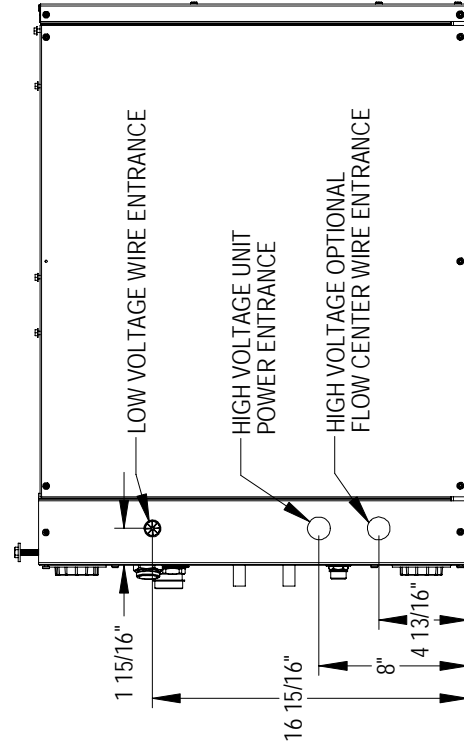
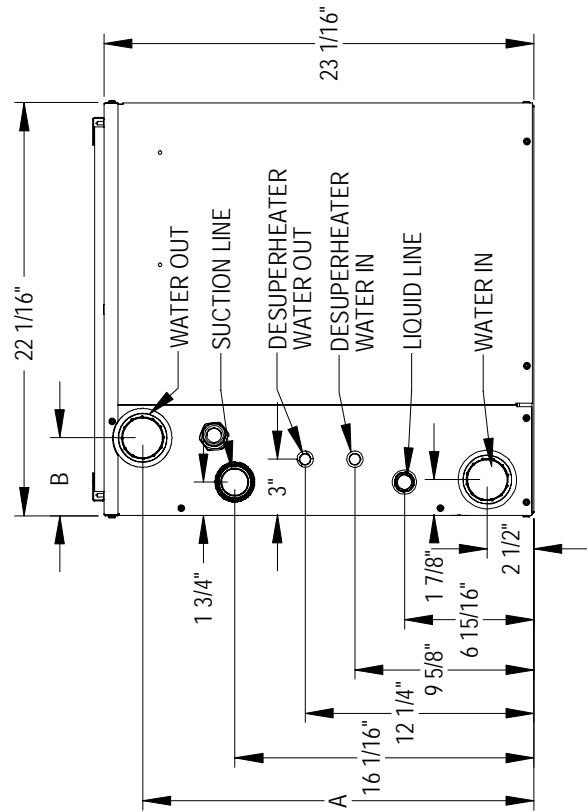

MIS-2820 A

FIGURE 1E – ASSEMBLED UPFLOW / COUNTERFLOW APPLICATION DIMENSIONS

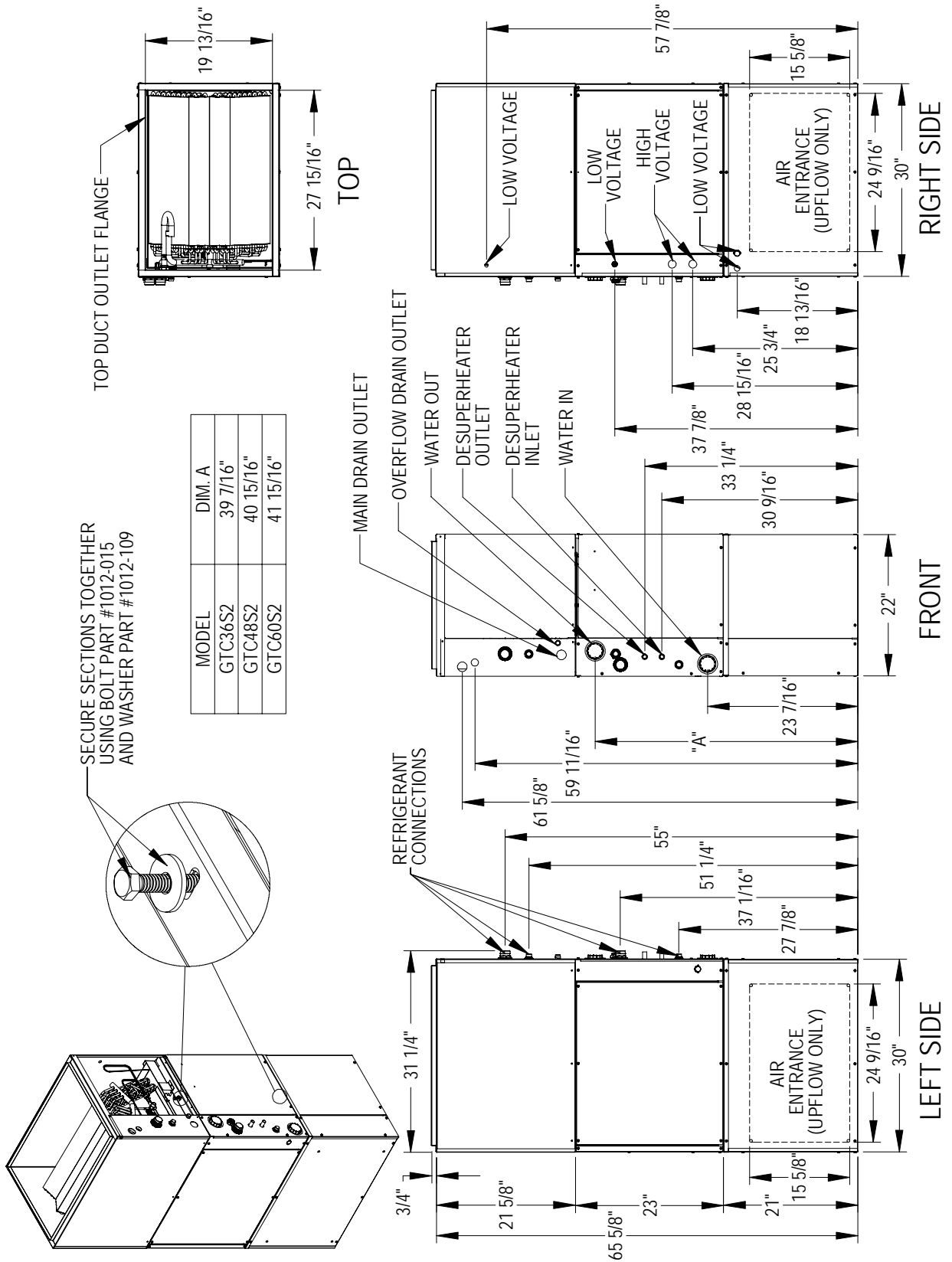

MIS-2821 B

FIGURE 1F – HORIZONTAL APPLICATION DIMENSIONS

*Evaporator and Blower in Horizontal Position
(Remote Compressor Section)*

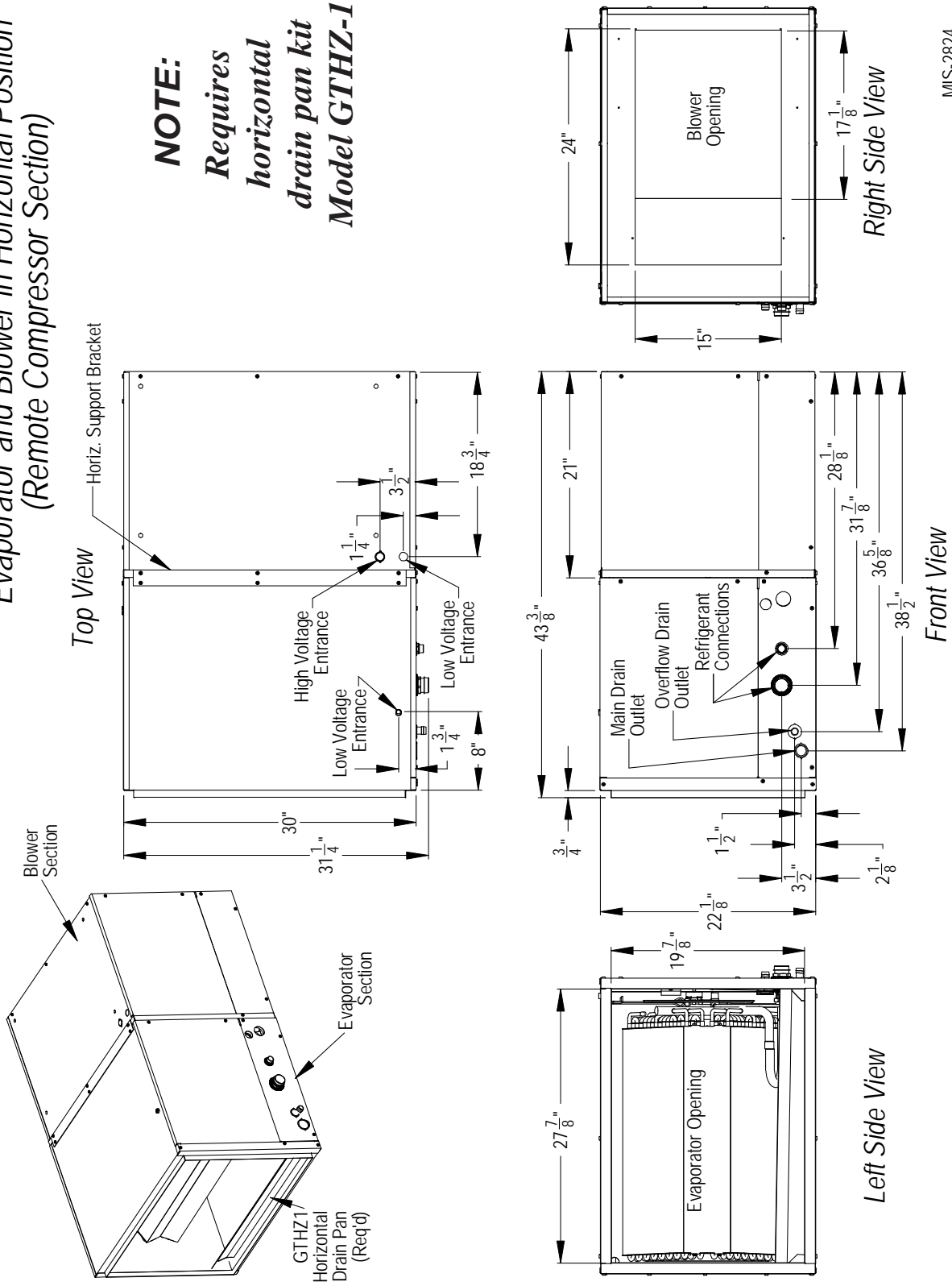

MIS-2824

FIGURE 2A – UPFLOW & COUNTERFLOW DUCTING CONFIGURATIONS

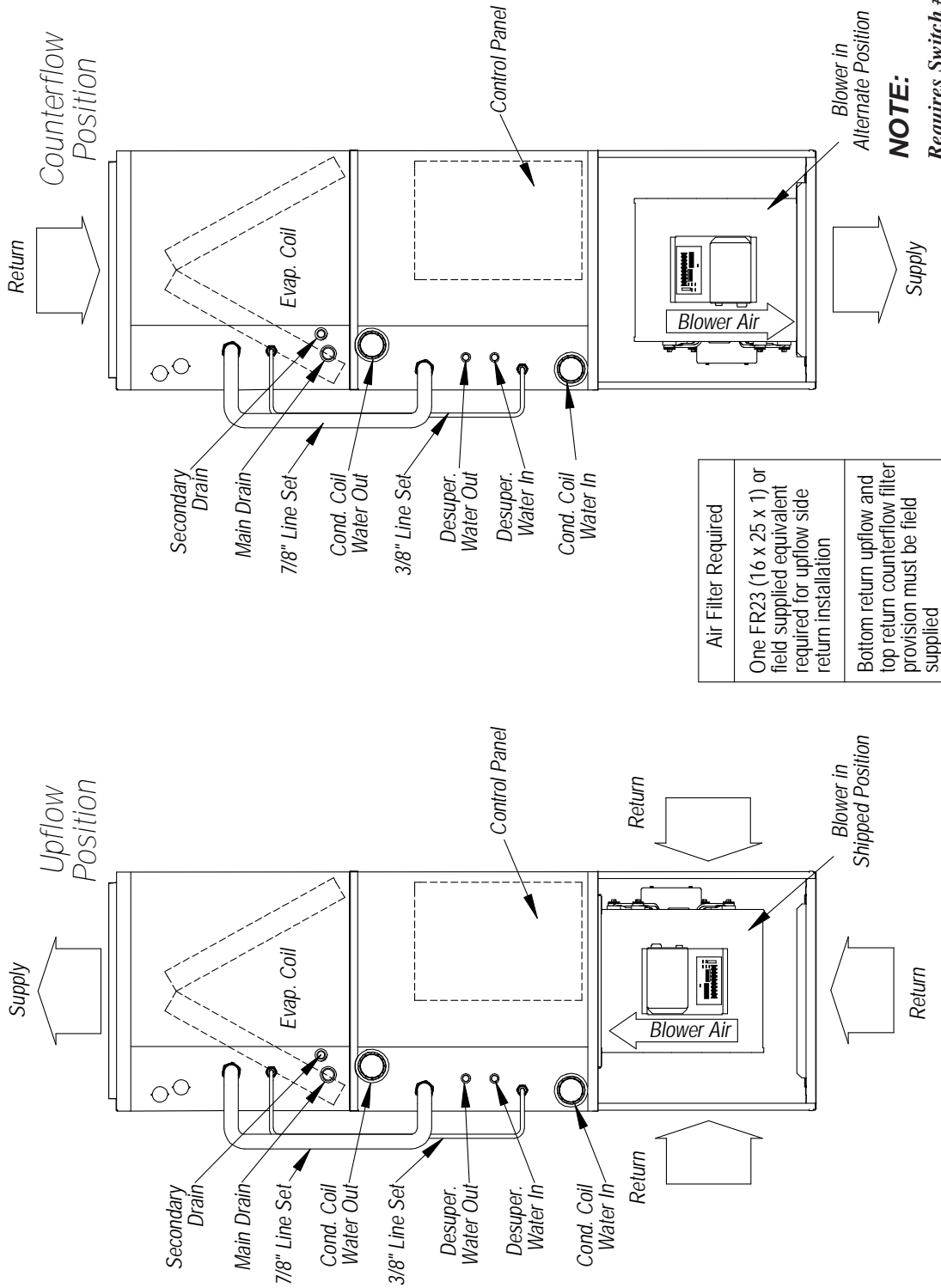

Air Filter Required
One FR23 (16 x 25 x 1) or field supplied equivalent required for upflow side return installation
Bottom return upflow and top return counterflow filter provision must be field supplied

NOTE:
Requires Switch #4 on Tap Select Control to be Turned On.

FIGURE 2B – HORIZONTAL & COUNTERFLOW DUCTING CONFIGURATIONS

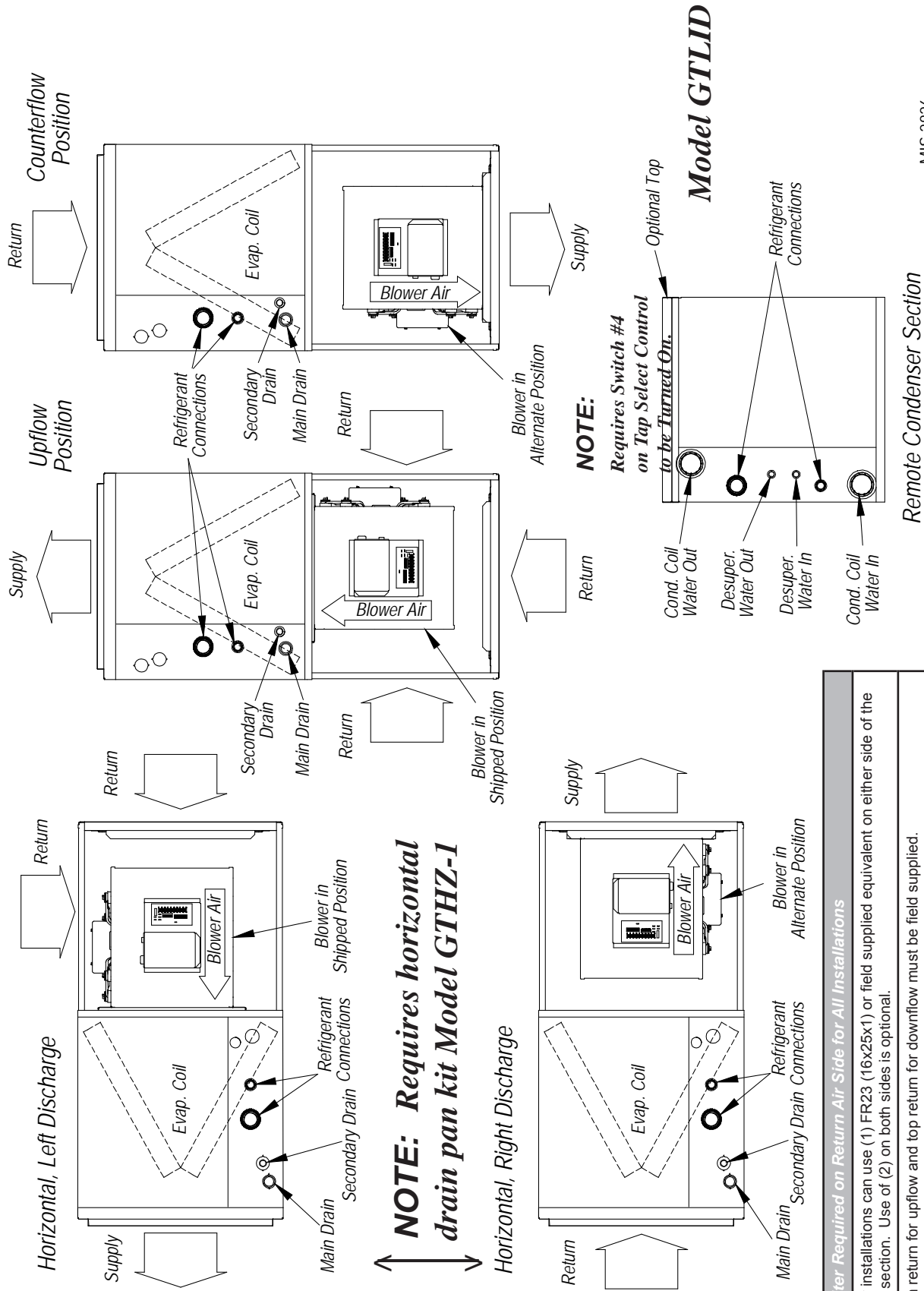

MIS-2826

NOTE: Requires horizontal drain pan kit Model GTHZ-1

Air Filter Required on Return Air Side for All Installations
Upflow installations can use (1) FR23 (16x25x1) or field supplied equivalent on either side of the blower section. Use of (2) on both sides is optional.
Bottom return for upflow and top return for downflow must be field supplied.
For horizontal attic or crawl space installations filter arrangement must be field supplied & should be located in readily accessible location for the user.
See additional information on Pages 19 & 20.

BLOWER CONVERSION FROM UPFLOW TO COUNTERFLOW OR HORIZONTAL RIGHT DISCHARGE

Following the directions on Figure 3 for counterflow and horizontal right discharge, the indoor blower must be removed and turned over in its mounting configuration.

- **Step 1** Remove both front service panels from the GTB1-A.
- **Step 2** Remove two screws securing blower at top of GTB1-A (See Figure 3), and slide the blower forward and out of the chassis.
- **Step 3** Remove two screws from front fill plate on bottom of GTB1-A, and slide both pieces of metal forward and out of chassis.
- **Step 4** Dip switch #4 on blower tap select control must be turned “on”. (Refer to Wiring Diagram 4117-100.)
- **Step 5** While turning on tap #4 above, adjust the other taps accordingly for the tonnage of unit being applied. (Refer to Wiring Diagram 4117-100.)
- **Step 6** Turn blower over and slide into rails of bottom rear of the GTB1-A front fill plate that was removed in Step 3 above.
- **Step 7** Remove bottom rear fill plate from bottom front fill plate (discard rear), and resecure front fill plate into unit base and front of blower.
- **Step 8** Replace GTB1-A front service doors after making line and control voltage wiring connections.

BLOWER LINE POWER CONNECTION

Power connections for the GTB1-A can be made two different ways.

The first is in “stacked” configurations, the blower can be plugged into an electrical connection from the bottom of the compressor (GTC**S2 Model Unit). This will work for either upflow or counterflow applications. All electrical sizing has been sized to accommodate this.

The second is with “remote” blower (meaning separate from the compressor section). Supplied in the GTB1-A is an adaptor wire harness. On the right-hand side of the GTB1-A chassis is a ½" electrical knockout. This harness can be installed through this knockout with the supplied strain relief into a standard electrical junction box (field supplied). Electrical load sizing is included on the serial plate of the GTB1-A for the required separate branch circuit (See Figure 4).

FIGURE 3 – BLOWER CONFIGURATIONS

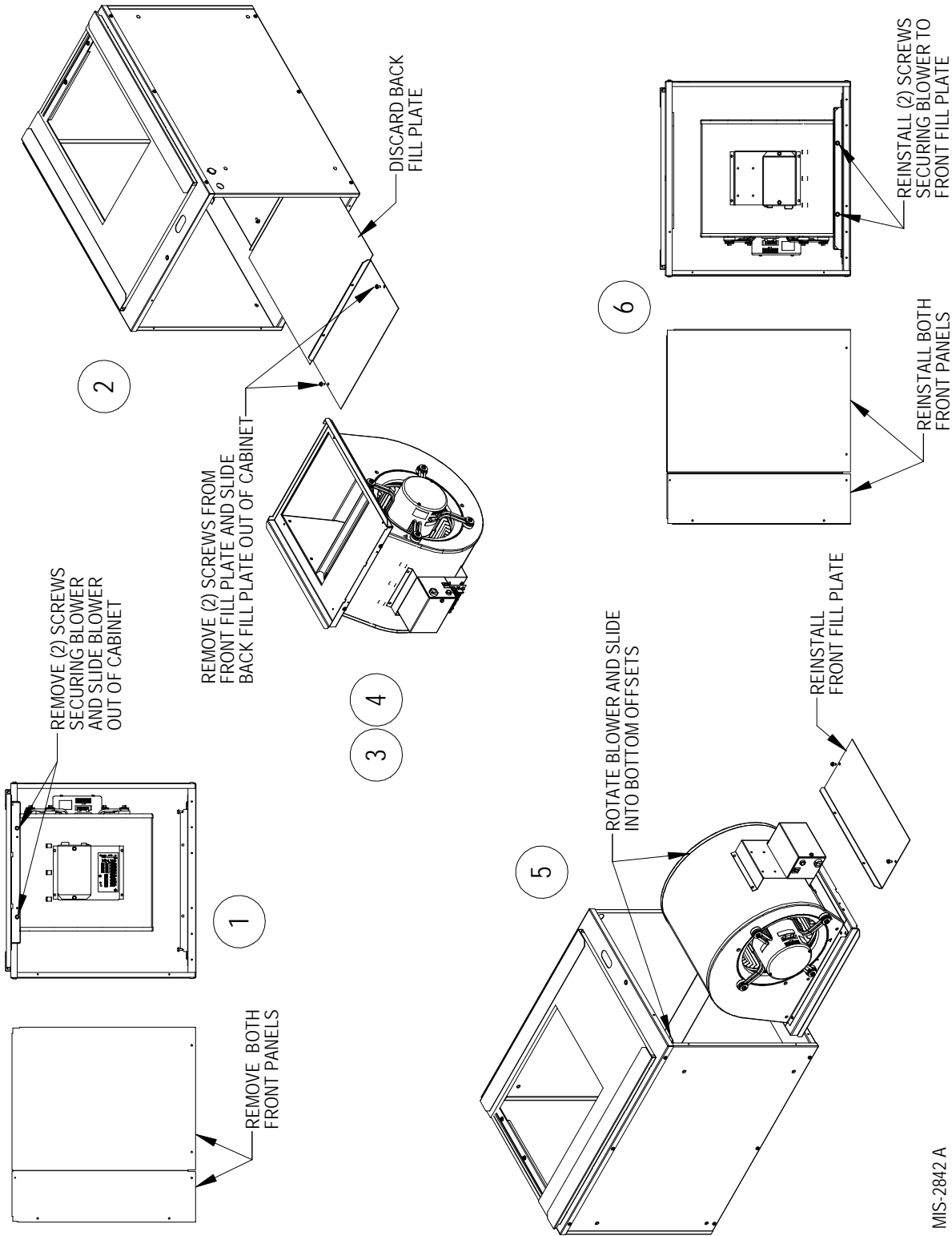

MIS-2842 A

FIGURE 4 – BLOWER POWER CONNECTIONS

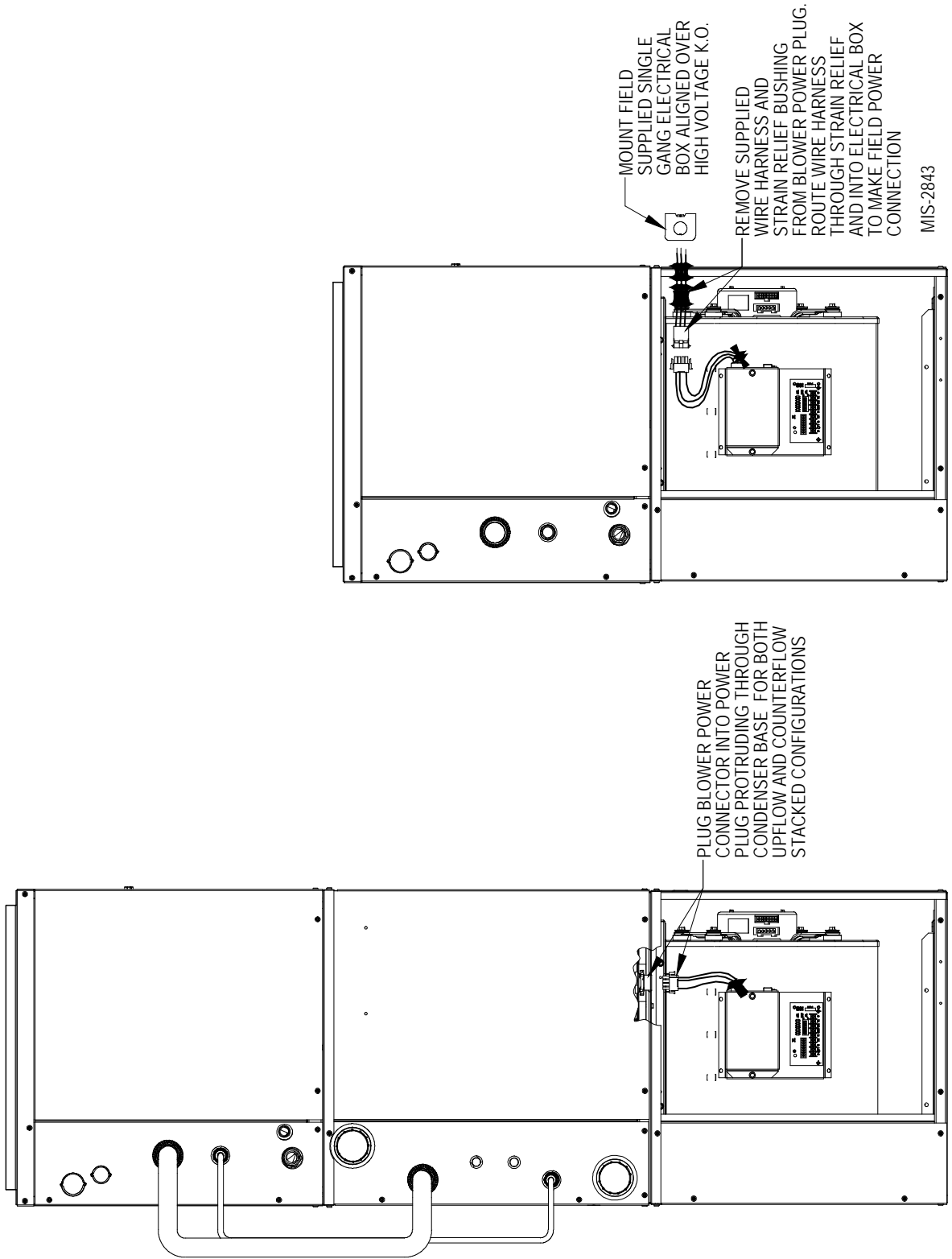

APPLICATION AND LOCATION

GENERAL

The GT Series Geothermal Heat Pumps feature three sections (GTA - Air Coil Section, GTB - Blower Section and GTC - Compressor Section) which cover upflow (bottom, right/left-side return), counterflow and horizontal (left and right-hand discharge) applications.

The individual sections are shipped internally wired, requiring duct connections, thermostat wiring, 230/208 volt AC power wiring, refrigerant line connections and water piping. The equipment covered in this manual is to be installed by trained, experienced service and installation technicians.

For installations requiring the continued use of an existing gas or oil fired furnace, add-on cased "A" coils are available. Two 3-ton coils designed to fit standard "B" and "C" width furnaces and one 4/5 ton coil designed for a "C" cabinet are available. Refer to Page 4 of this manual for the model nomenclature and the specification sheet for performance data.

For top discharge oil furnaces, the coil drain pan **MUST** be located a minimum of 6 inches above the top of the furnace cabinet. Two coil spacer accessories are available to fit Bard oil furnaces:

CSADP2220 22" x 20" x 6"
All models except 140,000 Btu Low-Boy
CASDP2520 25" x 20" x 6"
140,000 Btu Low-Boy only

For all other brands, a coil support system must be field fabricated to maintain the 6" spacing.

These instructions and any instructions packaged with any separate equipment required to make up the entire heat pump system should be carefully read before beginning the installation. Note particularly any tags and/or labels attached to the equipment.

While these instructions are intended as a general recommended guide, they do not in any way supersede any national and/or local codes. Authorities having jurisdiction should be consulted before the installation is made.

SHIPPING DAMAGE

Upon receipt of the equipment, the carton should be checked for external signs of shipping damage. If damage is found, the receiving party must contact the last carrier immediately, preferably in writing, requesting inspection by the carrier's agent.

APPLICATION

Capacity of the unit for a proposed installation should be based on heat loss calculations made in accordance with methods of the Air Conditioning Contractors of America. The air duct system should be sized and installed in accordance with Standards of the National Fire Protection Association for the Installation of Air Conditioning and Venting systems of Other than Residence Type NFPA No. 90A, and residence Type Warm Air Heating and Air Conditioning Systems, NFPA No. 90B.

DUAL FUEL HEATING / COOLING

Dual fuel is the combination of a fossil fuel furnace, normally gas or oil, with a heat pump. In milder weather the heat pump uses the available outdoor warmth and will transport that heat into your house cheaper than burning gas or oil. When it gets very cold, around 35 degrees F., the heat pump automatically shuts down and the furnace heats the home. This combination gives you the maximum savings on both heating and cooling while providing you with ideal indoor comfort.

Dual fuel systems are becoming increasingly popular in lieu of conventional high efficiency furnaces with air conditioning due to the energy savings and ease of installation. Today's new hi-tech thermostats eliminate the need for complicated wiring and dual fuel control boards. Bard recommends using the Honeywell THX9321R5030 Prestige® Thermostat (Does not include outdoor sensor). Honeywell also offers the Prestige® Kit 2.0 which includes the THX9321R5030 Prestige® Thermostat, REM5000R1001 Portable Comfort Control and C7089R1013 Wireless Outdoor Sensor.

LOCATION

The unit may be installed in a basement, closet, or utility room provided adequate service access is ensured.

These units are not approved for outdoor installation and therefore must be installed inside the structure being conditioned. ***Do not locate in areas subject to freezing in the winter or subject to sweating in the summer.***

Before setting the unit, consider ease of piping, drain and electrical connections for the unit. Also, for units which will be used with a desuperheater unit, consider the proximity of the unit to the water heater or storage tank. Place the unit on a solid base, preferably concrete, to minimize undesirable noise and vibration. ***DO NOT*** elevate the base pan on rubber or cork vibration eliminator pads as this will permit the unit base to act like a drum, transmitting objectionable noise.

DUCTWORK

If the unit is to be installed in a closet or utility room which does not have a floor drain, a secondary drain pan under the entire unit is highly recommended.

DO NOT install the unit in such a way that a direct path exists between any return grille and the unit. Rather, insure that the air entering the return grille will make at least one turn before entering the unit or coil. This will reduce possible objectionable compressor and air noise from entering the occupied space.

Design the ductwork according to methods given by the Air Conditioning Contractors of America. When duct runs through unconditioned spaces, it should be insulated with vapor barrier. It is recommended that flexible connections be used to connect the ductwork to the unit in order to keep the noise transmission to a minimum.



WARNING

In applying a duct heater, refer to duct heater installation instructions for minimum clearance to combustible materials, maximum allowed inlet air temperatures, and minimum air volume requirements for KW usage.



CAUTION

NEVER OPERATE MORE THAN 10KW STRIP HEAT WITH GEOTHERMAL HEAT PUMP OPERATIONAL. USE ADDITIONAL KW STRIP HEAT BEYOND 10KW ONLY IN EMERGENCY HEAT MODE.

**TABLE 5
ELECTRICAL HEAT SPECIFICATIONS**

For Use With	Heater Package	Heater Package	240 Volts			208 Volts			Minimum Circuit Ampacity	Maximum HACR Circuit Breaker	Field Wire Size +
			KW	Amps	BTUH	KW	Amps	BTUH			
All GTC*S2 Models	8604-080	240/208-60-1	5.0	20.8	17,065	3.75	18.0	12,799	26.0	30	#10
	8604-081	240/208-60-1	9.8	40.8	33,447	7.35	35.3	25,086	52.0	60	#6
	8604-082	240/208-60-1	14.7	61.2	50,171	11.0	52.9	37,543	76.6	80	#4
	8604-083	240/208-60-1	19.2	81.7	65,530	14.4	69.2	49,147	102.0	125	#1

+ Based upon 75°C copper wire. All wiring must conform to National Electric Code (Latest Edition) and all local codes.

FILTER

This unit must NOT be operated without a filter installed on return air side of the system. Insufficient airflow due to undersized duct systems, inadequate filter size, or dirty filters can result in nuisance tripping of the high or low pressure controls. The ductwork and filter sizing must be designed per ASHRAE/ACCA Guidelines.

Step #1 Refer to Table 1 (Page 4) for specific unit airflow and static application information.

Step #2 Refer to Figures 5A, 5B, 5C and 5D (Page 20) for typical installation filter configurations for your specific application.

Step #3 Refer to Table 6 Filter Sizing Chart (Page 19) matching your airflow and filter configuration to determine proper filter sizing.

CONDENSATE DRAIN

Drain lines must be installed according to local plumbing codes. It is not recommended that any condensate drain line be connected to a sewer main.

NOTE: *This drain line will contain cold water and must be insulated to avoid droplets of water from compressor on the pipe and dripping on finished floors or the ceiling below the unit.*

PIPING ACCESS TO UNIT

Water piping to and from the unit enters the unit cabinet on the left side of the unit. The connection directly at the unit is a special double o-ring fitting with a retainer nut that secures it in place. (It is the same style fitting used for the flow center connection on ground loop applications.)

NOTE: *All double o-ring fittings require "hand tightening only". Do not use wrench or pliers as retainer nut can be damaged with excessive force.*

NOTE: *Apply petroleum jelly to o-rings to prevent damage and to aid in insertion.*

Various fittings are available so you may then connect to the unit with various materials and methods. These methods include 1" barbed fittings (straight and 90°), 1" MPT (straight and 90°), and 1-1/4" hot fusion fitting (straight only) (see Figure 7).

**TABLE 6
FILTER SIZING CHART**

Filter Nominal Size	Surface Area FT ²	Filter Type	Airflow CFM Capability @ 300 FPM Velocity	Airflow CFM Capability @ 500 FPM Velocity	Airflow CFM Capability @ 625 FPM Velocity
10" X 20" X 1"	1.39	1" Fiberglass Disposable	415	Not Recommended	Not Recommended
12" X 20" X 1"	1.67		500		
14" X 20" X 1"	1.94		580		
14" X 25" X 1"	2.43		730		
16" X 20" X 1"	2.22		670		
16" X 25" X 1"	2.78		840		
20" X 20" X 1"	2.78		840		
20" X 25" X 1"	3.47		1050		
24" X 24" X 1"	4.00		1200		
10" X 20" X 2"	1.39		2" Std. Fiberglass Disposable		
12" X 24" X 2"	2.00	600		1000	
14" X 20" X 2"	1.94	580		975	
14" X 25" X 2"	2.43	730		1215	
16" X 20" X 2"	2.22	670		1120	
16" X 25" X 2"	2.78	840		1400	
20" X 20" X 2"	2.78	840		1400	
20" X 25" X 2"	3.47	1050		1750	
24" X 24" X 2"	4.0	1200		2000	
10" X 20" X 1"	1.39	1" Pleated Filter		425	700
12" X 24" X 1"	2.00		600	1000	
14" X 20" X 1"	1.94		590	980	
14" X 25" X 1"	2.43		730	1215	
16" X 20" X 1"	2.22		670	1115	
16" X 25" X 1"	2.78		840	1400	
20" X 20" X 1"	2.78		840	1400	
20" X 25" X 1"	3.47		1050	1740	
24" X 24" X 1"	4.00		1200	2000	
10" X 20" X 2"	1.39		2" Pleated Filter	425	700
12" X 24" X 2"	2.00	600		1000	1250
14" X 20" X 2"	1.94	590		980	1215
14" X 25" X 2"	2.43	730		1215	1520
16" X 20" X 2"	2.22	670		1115	1400
16" X 25" X 2"	2.78	840		1400	1740
20" X 20" X 2"	2.78	840		1400	1740
20" X 25" X 2"	3.47	1050		1740	2170
24" X 24" X 2"	4.00	1200		2000	2500
12" X 24" X 4"	2	4" Pleated Filter		600	1000
16" X 20" X 4"	2.22		670	1115	1400
20" X 20" X 4"	2.78		840	1400	1740
20" X 25" X 4"	3.47		1050	1740	2170
24" X 24" X 4"	4		1200	2000	2500

To self-calculate for additional filter sizes:

Airflow / Nominal Filter Size (FT²) = Velocity

1600 CFM / 3.47 (20" x 25" filter) = 461 FPM (feet per minute velocity)

AIR FILTER APPLICATIONS

FIGURE 5A

UPFLOW

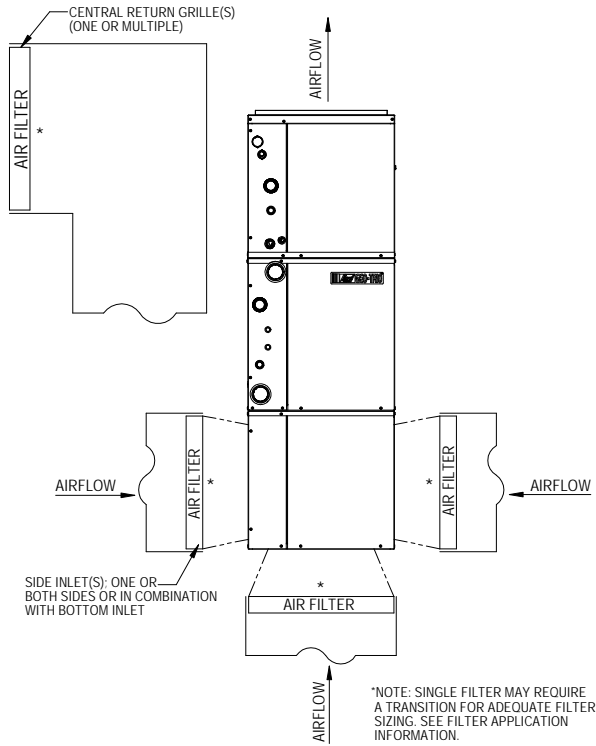

MIS-2881

FIGURE 5B

COUNTERFLOW

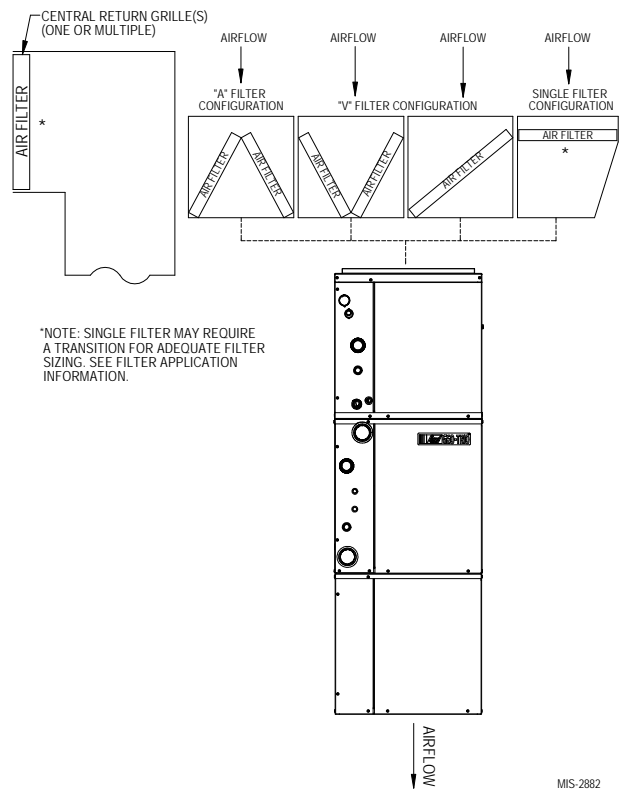

MIS-2882

FIGURE 5C

HORIZONTAL LEFT DISCHARGE

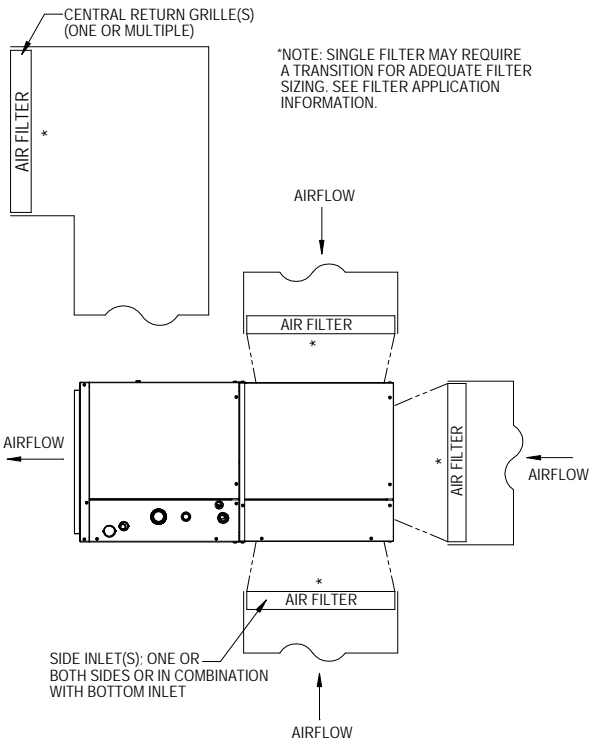

MIS-2883

FIGURE 5D

HORIZONTAL FRONT DISCHARGE

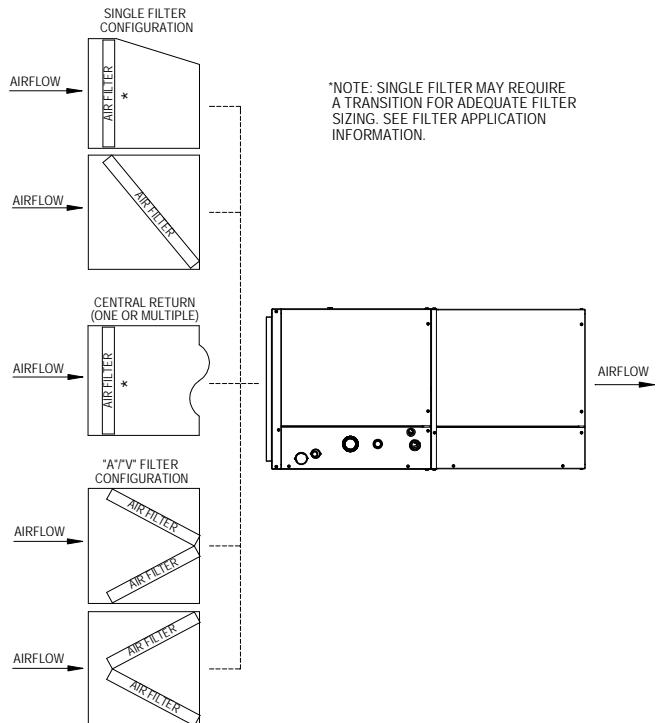

MIS-2884

FILTERS SHOULD ALWAYS BE APPLIED IN A MANNER THAT MAKES THEM EASY TO ACCESS & CHANGE.

WIRING INSTRUCTIONS

GENERAL

All wiring must be installed in accordance with the National Electrical Code and local codes. In Canada, all wiring must be installed in accordance with the Canadian Electrical Code and in accordance with the regulations of the authorities having jurisdiction. Power supply voltage must conform to the voltage shown on the unit serial plate. A wiring diagram of the unit is attached to the inside of the electrical cover. The power supply shall be sized and fused according to the specifications supplied. A ground lug is supplied in the control compartment for equipment ground.

The unit rating plate lists a “Maximum Time Delay Fuse” or “HACR” type circuit breaker that is to be used with the equipment. The correct size must be used for proper circuit protection and also to assure that there will be no nuisance tripping due to the momentary high starting current of the compressor motor.

CONTROL CIRCUIT WIRING

The minimum control circuit wiring gauge needed to insure proper operation of all controls in the unit will depend on two factors.

1. The rated VA of the control circuit transformer.
2. The maximum total distance of the control circuit wiring.

Table 6 should be used to determine proper gauge of control circuit wiring required.

For low voltage connections, see Figure #6. There are multiple options based upon the type of installation in regards to low voltage electrical connections and what options are selected. These options include a motorized valve or motorized valve with end switch for ground water applications, and optional electric duct heater connections.

NOTE: Review the “lettered triangles” and the corresponding notes on the lower right-hand corner of Figure #6. When options are not used, the wires will need attached to the reference points accordingly.

Example:

1. Control Circuit transformer rated at 50 VA
2. Maximum total distance of control circuit wiring 85 feet.

From Table 7 minimum of 16 gauge wire should be used in the control circuit wiring.

**TABLE 7
CONTROL CIRCUIT WIRING**

Rated VA of Control Circuit Transformer	Transformer Secondary FLA @ 24V	Maximum Total Distance of Control Circuit Wiring in Feet
50	2.1	20 gauge - 45 18 gauge - 60 16 gauge - 100 14 gauge - 160 12 gauge - 250

WALL THERMOSTAT SELECTION

The wall thermostat selection is important in that it needs to be minimally 2-stage heat and 2-stage cool for applications without electric heat.

For applications with electric heat, the thermostat will need to minimally be 3-stage heat and 2-stage cool. The second bank of electric heat (when equipped) should be wired through a secondary relay for operation only in Emergency Heat Mode, at which point compressor operation should be disabled.

Refer to Figure 6 on the following page for typical thermostat connections.

Low Voltage Connection

These units use a grounded 24-volt AC low voltage circuit and require at least a 2-stage heating and a 2-stage cooling thermostat.

“R” terminal is 24 VAC *hot*.

“C” terminal is 24 VAC *grounded*.

“G” terminal is the *fan input*.

“Y1” terminal is the *compressor part load input*.

“Y2” terminal is the *compressor full load input*.

“O” terminal is the *reversing valve input*. The reversing valve must be energized for cooling mode.

“L” terminal is the *check light output/compressor lockout*. This terminal is activated on high pressure switch, low pressure switch, condensate overflow, or freeze stat trip. This is a 24 VAC output.

“W1” terminal is *first stage electric heat input*. (If equipped.)

“E” terminal is the *emergency heat input*. This energizes the emergency heat relay, and should be utilized to limit the amount of electric heat with the geothermal heat pump operational to limit outlet air temperature.

“W2” terminal is the *second stage electric heat input*. (If equipped.)

**FIGURE 6
THERMOSTAT WIRING**

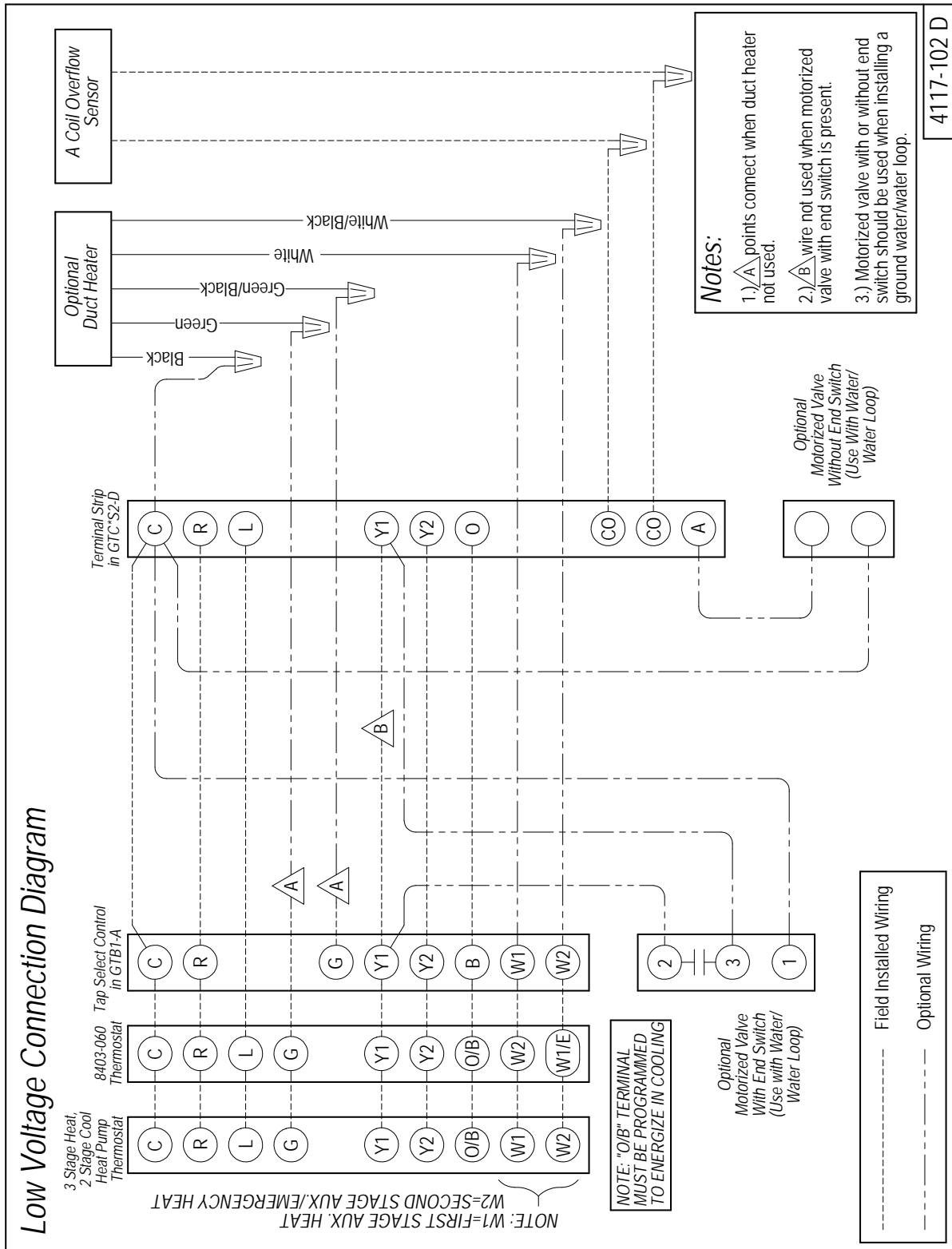

GROUND LOOP (EARTH COUPLED WATER LOOP APPLICATIONS)

NOTE:

Unit shipped from factory with 75 PSIG low pressure switch wired into control circuit and must be rewired to 55 PSIG low pressure switch for ground loop applications. This unit is designed to work on earth coupled water loop systems, however, these systems operate at entering water (without antifreeze) temperature with pressures well below the pressures normally experienced in water well systems.

THE CIRCULATION SYSTEM DESIGN

Equipment room piping design is based on years of experience with earth coupled heat pump systems. The design eliminates most causes of system failure.

The heat pump itself is rarely the cause. Most problems occur because designers and installers forget that a ground loop "earth coupled" heat pump system is NOT like a household plumbing system.

Most household water systems have more than enough water pressure either from the well pump or the municipal water system to overcome the pressure of head loss in 1/2 inch or 3/4 inch household plumbing. A closed loop earth coupled heat pump system, however, is separated from the pressure of the household supply and relies on a small, low wattage pump to circulate the water and antifreeze solution through the earth coupling, heat pump and equipment room components.

The small circulator keeps the operating costs of the system to a minimum. However, the performance of the circulator MUST be closely matched with the pressure of head loss of the entire system in order to provide the required flow through the heat pump. Insufficient flow through the heat exchanger is one of the most common causes of system failure. Proper system piping design and circulator selection will eliminate this problem.

FIGURE 7
CIRCULATION SYSTEM DESIGN

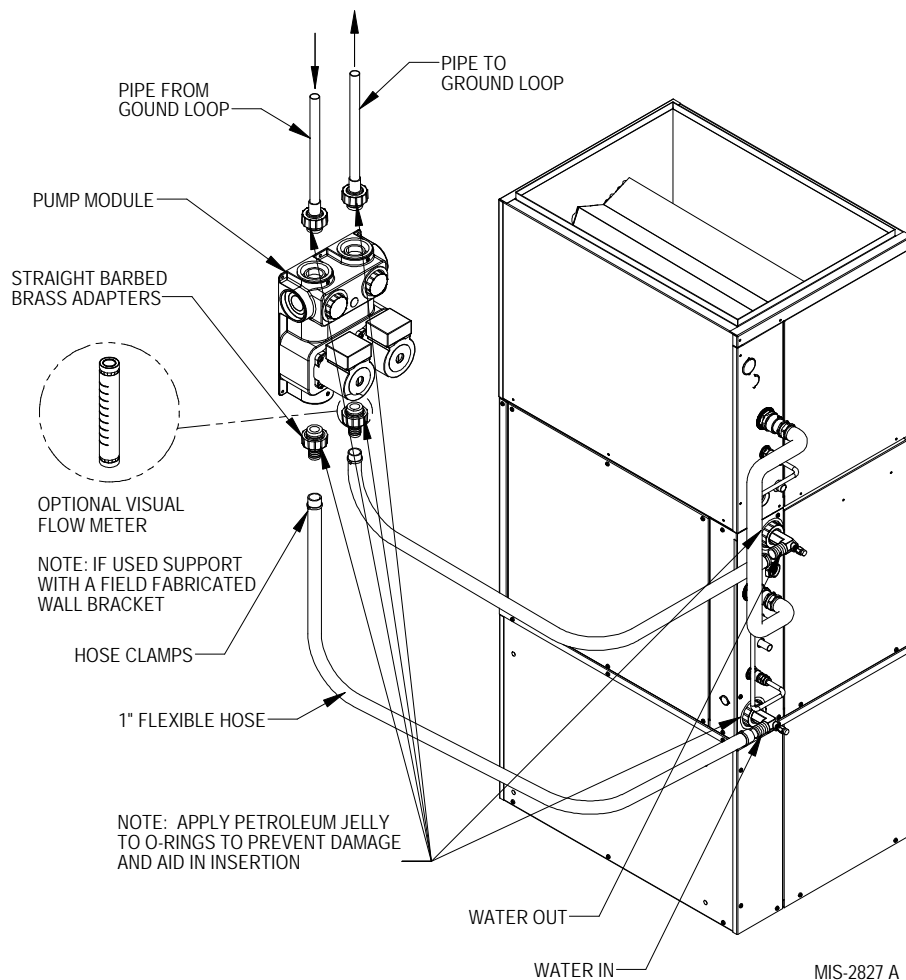

START UP PROCEDURE FOR GROUND LOOP SYSTEM

1. Be sure main power to the unit is OFF at disconnect.
 2. Set thermostat system switch to OFF, fan switch to AUTO.
 3. Move main power disconnect to ON. Except as required for safety while servicing, *DO NOT OPEN THE UNIT DISCONNECT SWITCH*.
 4. Check system airflow for obstructions.
 - A. Move thermostat fan switch to ON. Blower runs.
 - B. Be sure all registers and grilles are open.
 - C. Move thermostat fan switch to AUTO. Blowing should stop.
 5. Flush, fill and pressurize the closed loop system per IGSHPA guidelines.
 6. Fully open the manual inlet and outlet valves. Start the loop pump module circulator(s) and check for proper operation. If circulator(s) are not operating, turn off power and diagnose the problem.
 7. Check fluid flow using a direct reading flow meter or a single water pressure gauge, measure the pressure drop at the pressure/temperature plugs across the water coil. Compare the measurement with flow versus pressure drop table to determine the actual flow rate. If the flow rate is too low, recheck the selection of the loop pump module model for sufficient capacity. If the module selection is correct, there is probably trapped air or a restriction in the piping circuit.
 8. Start the unit in cooling mode by moving the thermostat switch to cool. Fan should be set for AUTO.
 9. Check the system refrigerant pressures against the cooling refrigerant pressure table in the installation manual for rated water flow and entering water temperatures. If the refrigerant pressures do not match, check for airflow problem then refrigeration system problem.
 10. Switch the unit to the heating mode by moving the thermostat switch to heat. Fan should be set for AUTO.
 11. Check the refrigerant system pressures against the heating refrigerant pressure table in installation manual. Once again, if they do not match, check for airflow problems and then refrigeration system problems.
- NOTE:* If a charge problem is determined (high or low):
- A. Check for possible refrigerant leaks.
 - B. Recover all remaining refrigerant from unit and repair leak.
 - C. Evacuate unit down to 29 inches of vacuum.
 - D. Recharge the unit with refrigerant by weight. This is the only way to insure a proper charge.

FIGURE 8

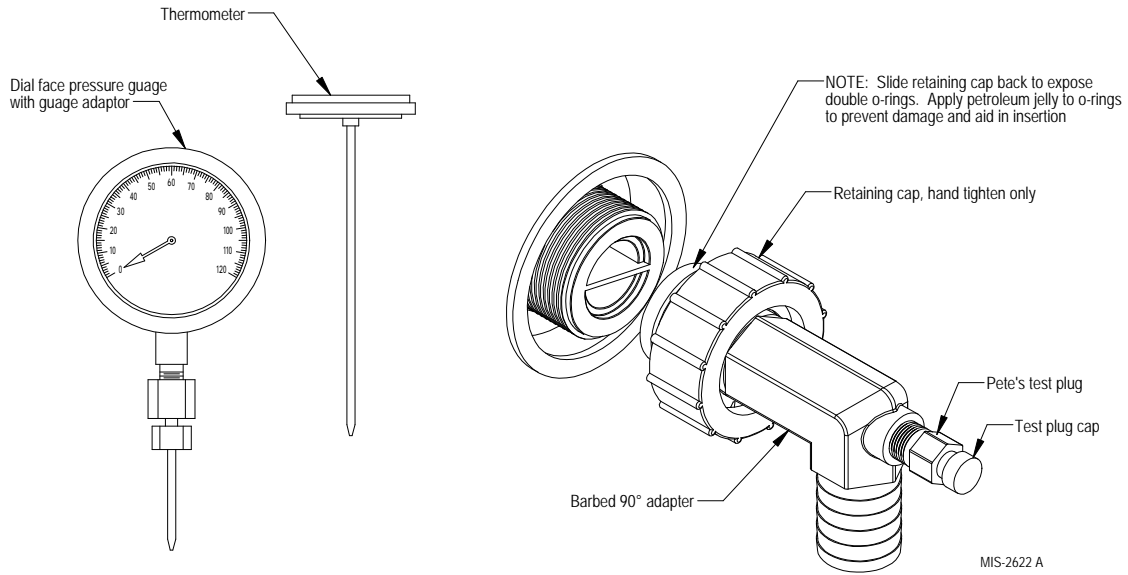

**FIGURE 9
PERFORMANCE MODEL DORFC-1 FLOW CENTER**

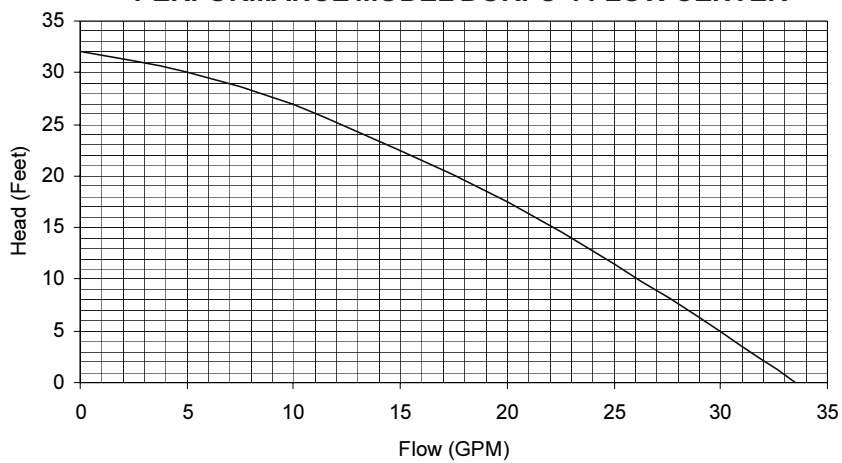

**FIGURE 10
PERFORMANCE MODEL DORFC-2 FLOW CENTER**

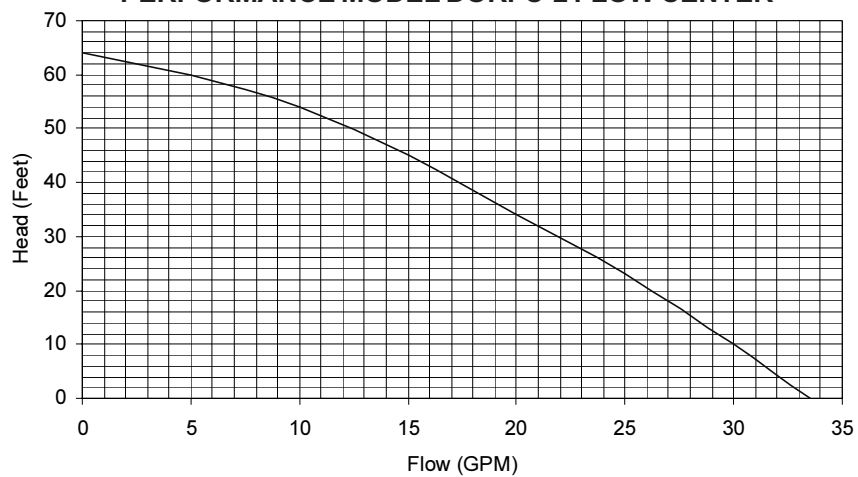

GROUND WATER (WELL SYSTEM APPLICATIONS)

NOTE:

It is highly recommended on ground water systems (pump & dump) that a cupronickel coaxial coil is utilized on the source side of the system. Not doing so may void the product warranty due to aggressive/corrosive/highly oxygenated water attacking a copper coaxial water coil.

NOTE:

Unit shipped from factory with 60 PSIG low pressure switch wired into control circuit for ground water applications.

WATER CONNECTIONS

It is very important that an adequate supply of clean, non-corrosive water at the proper pressure be provided before the installation is made. Insufficient water, in the heating mode for example, will cause the low pressure switch to trip, shutting down the heat pump. In assessing the capacity of the water system, it is advisable that the complete water system be evaluated to prevent possible lack of water or water pressure at various household fixtures whenever the heat pump turns on. All plumbing to and from the unit is to be installed in accordance with local plumbing codes. The use of plastic pipe, where permissible, is recommended to prevent electrolytic corrosion of the water pipe. Because of the relatively cold temperatures encountered with well water, it is strongly recommended that the water lines connecting the unit be insulated to prevent water droplets from condensing on the pipe surface.

Refer to piping, Figure 11. Slow open/close with **End Switch (2)**, 24V, provides on/off control of the water flow to the unit. Refer to the wiring diagram for correct hookup of the valve solenoid coil.

**TABLE 8
CONSTANT FLOW VALVES**

Part No.	Min. Available Pressure PSIG	Flow Rate GPM
CFV-5	15 (1)	5
CFV-6	15 (1)	6
CFV-7	15 (1)	7
CFV-9	15 (1)	9
CFV-10	15 (1)	10

(1) The pressure drop through the constant flow valve will vary depending on the available pressure ahead of the valve. Unless minimum of 15 psig is available **immediately** ahead of the valve, no water will flow.

Constant Flow Valve (3) provides correct flow of water to the unit regardless of variations in water pressure. Observe the water flow direction indicated by the arrow on the side of the valve body. Following is a table showing which valve is to be installed with which heat pump.

Strainer (8) installed upstream of **water coil inlet** to collect foreign material which would clog the flow valve orifice.

The figure shows the use of **shutoff valves (4) and (5)**, on the in and out water lines to permit isolation of the unit from the plumbing system should future service work require this. Globe valves should not be used as shutoff valves because of the excessive pressure drop inherent in the valve design. Instead use gate or ball valves as shutoffs, so as to minimize pressure drop.

Hose bib (6) and (7), and tees should be included to permit acid cleaning the refrigerant-to-water coil should such cleaning be required. See WATER CORROSION.

Hose bib (1) provides access to the system to check water flow through the constant flow valve to insure adequate water flow through the unit. A water meter is used to check the water flow rate.

WELL PUMP SIZING

Strictly speaking, sizing the well pump is the responsibility of the well drilling contractor. It is important, however, that the HVAC contractor be familiar with the factors that determine what size pump will be required. Rule of thumb estimates will invariably lead to under or oversized well pumps. Undersizing the pump will result in inadequate water to the whole plumbing system, but with especially bad results to the heat pump – NO HEAT / NO COOL calls will result. Oversized pumps will short cycle and could cause premature pump motor or switch failures.

The well pump must be capable of supplying enough water and at an adequate pressure to meet competing demands of water fixtures. The well pump must be sized in such a way that three requirements are met:

1. Adequate flow rate in GPM.
2. Adequate pressure at the fixture.
3. Able to meet the above from the depth of the well-feet of lift.

The pressure requirements put on the pump are directly affected by the diameter of pipe being used, as well as, by the water flow rate through the pipe. The worksheet included in Manual 2100-078 should guarantee that the well pump has enough capacity. It should also ensure that

the piping is not undersized, which would create too much pressure due to friction loss. High pressure losses due to undersized pipe will reduce efficiency and require larger pumps and could also create water noise problems.

FIGURE 11
WATER CONNECTION COMPONENTS

NOTE:

Shown with Optional Top Kit for Remote Condenser Applications

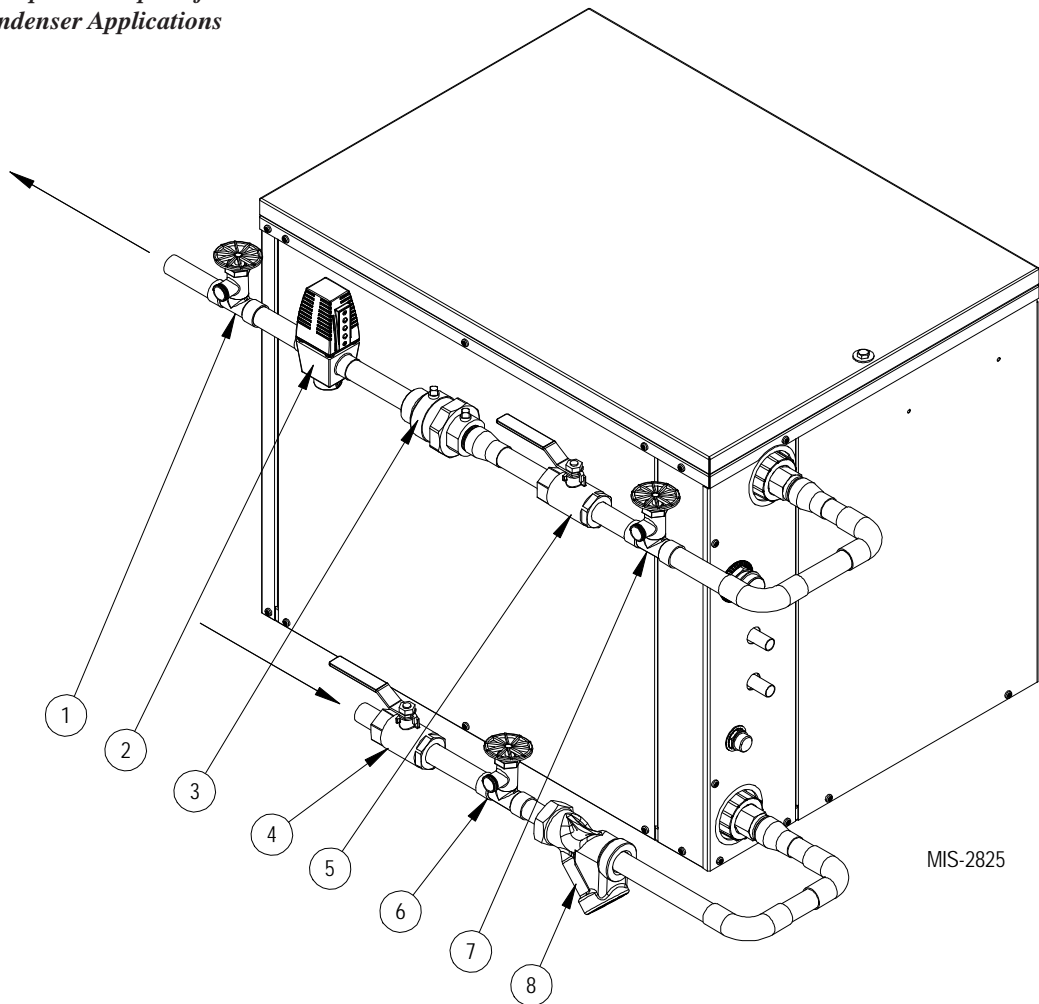

See descriptions for these reference numbers on Page 27.

SYSTEM START UP PROCEDURE FOR GROUND WATER APPLICATIONS

1. Be sure main power to the unit is OFF at disconnect.
2. Set thermostat system switch to OFF, fan switch to AUTO.
3. Move main power disconnect to ON. Except as required for safety while servicing – *DO NOT OPEN THE UNIT DISCONNECT SWITCH.*
4. Check system airflow for obstructions.
 - A. Move thermostat fan switch to ON. Blower runs.
 - B. Be sure all registers and grilles are open.
 - C. Move thermostat fan switch to AUTO. Blower should stop.
5. Fully open the manual inlet and outlet valves.
6. Check water flow.
 - A. Connect a water flow meter to the drain cock between the constant flow valve and the solenoid valve. Run a hose from the flow meter to a drain or sink. Open the drain cock.
 - B. Check the water flow rate through constant flow valve to be sure it is the same as the unit is rated for. (Example: 6 GPM for a GTC36S2.)
 - C. When water flow is okay, close drain cock and remove the water flow meter. The unit is now ready to start.
7. Start the unit in cooling mode by moving the thermostat switch to cool. Fan should be set for AUTO.
 - A. Check to see the solenoid valve opened.
8. Check the system refrigerant pressures against the cooling refrigerant pressure table in the installation manual for rated water flow and entering water temperatures. If the refrigerant pressures do not match, check for airflow problem and then refrigeration system problem.
9. Switch the unit to the heat mode by moving the thermostat switch to heat. Fan should be set for AUTO.
 - A. Check to see the solenoid valve opened again.
10. Check the refrigerant system pressures against the heating refrigerant pressure table in installation manual. Once again, if they do not match, check for airflow problems and then refrigeration system problems.

NOTE: If a charge problem is determined (high or low):

- A. Check for possible refrigerant loss.
- B. Discharge all remaining refrigerant from unit.
- C. Evacuate unit down to 29 inches of vacuum.
- D. Recharge the unit with refrigerant by weight. This is the only way to insure proper charge.

WATER CORROSION

Two concerns will immediately come to light when considering a water source heat pump, whether for ground water or for a ground loop application: Will there be enough water? And, how will the water quality affect the system?

Water quantity is an important consideration and one which is easily determined. The well driller must perform a pump down test on the well according to methods described by the National Well Water Association. This test, if performed correctly, will provide information on the rate of flow and on the capacity of the well. It is important to consider the overall capacity of the well when thinking about a water source heat pump because the heat pump may be required to run for extended periods of time.

The second concern, about water quality, is equally important. Generally speaking, if the water is not offensive for drinking purposes, it should pose no problem for the heat pump. The well driller or local water softening company can perform tests which will determine the chemical properties of the well water.

Water quality problems will show up in the heat pump in one or more of the following ways:

1. Decrease in water flow through the unit.
2. Decreased heat transfer of the water coil (entering to leaving water temperature difference is less).

There are four main water quality problems associated with ground water. These are:

1. **Biological Growth.** This is the growth of microscopic organisms in the water and will show up as a slimy deposit throughout the water system. Shock treatment of the well is usually required and this is best left up to the well driller. The treatment consists of injecting chlorine into the well casing and flushing the system until all growth is removed.
2. **Suspended Particles in the Water.** Filtering will usually remove most suspended particles (fine sand, small gravel) from the water. The problem with suspended particles in the water is that it will erode metal parts, pumps, heat transfer coils, etc. So long as the filter is cleaned and periodically maintained, suspended particles should pose no serious problem. Consult with your well driller.
3. **Corrosion of Metal.** Corrosion of metal parts results from either highly corrosive water (acid water, generally not the case with ground water) or galvanic reaction between dissimilar metals in the presence of water. By using plastic plumbing or dielectric unions, galvanic reaction is eliminated. The use of corrosion resistant materials such as the Cupronickel coil through the water system will reduce corrosion problems significantly.

4. **Scale Formation.** Of all the water problems, the formation of scale by ground water is by far the most common. Usually this scale is due to the formation of calcium carbonate but magnesium carbonate or calcium sulfate may also be present. Carbon dioxide gas (CO₂), the carbonate of calcium and magnesium carbonate, is very soluble in water. It will remain dissolved in the water until some outside factor upsets the balance. This outside influence may be a large change in water temperature or pressure. When this happens, enough carbon dioxide gas combines with dissolved calcium or magnesium in the water and falls out of solution until a new balance is reached. The change in temperature that this heat pump produces is usually not high enough to cause the dissolved gas to fall out of solution. Likewise, if pressure drops are kept to a reasonable level, no precipitation of carbon dioxide should occur.

REMEDIES OF WATER PROBLEMS

Water Treatment. Water treatment can usually be economically justified for water loop systems. However, because of the large amounts of water involved with a ground water system, water treatment is generally too expensive.

Acid Cleaning the Water Coil or Heat Pump Recovery Unit.

If scaling of the coil is strongly suspected, the coil can be cleaned up with a solution of Phosphoric Acid (food grade acid). Follow the manufacturer's directions for mixing, use, etc. Refer to the "Cleaning Water Coil", Figure 12. The acid solution can be introduced into the heat pump coil through the hose bib A. Be sure the isolation valves are closed to prevent contamination of the rest of the system by the coil. The acid should be pumped from a bucket into the hose bib and returned to the bucket through the other hose bib B. Follow the manufacturer's directions for the product used as to how long the solution is to be circulated, but it is usually circulated for a period of several hours.

LAKE AND POND INSTALLATIONS

Lakes and ponds can provide a low cost source of water for heating and cooling with a ground water heat pump. Direct usage of the water without some filtration is not recommended as algae and turbid water can foul the water to refrigerant heat exchanger. Instead, there have been very good results using a dry well dug next to the water line or edge. Normal procedure in installing a dry well is to backhoe a 15 to 20 foot hole adjacent to the body of water (set backhoe as close to the water's edge as possible). Once excavated, a perforated plastic casing should be installed with gravel backfill placed around the casing. The gravel bed should provide adequate filtration of the water to allow good performance of the ground water heat pump.

The following is a list of recommendations to follow when installing this type of system:

- A. A lake or pond should be at least 1 acre (40,000 square feet) in surface area for each 50,000 BTUs of ground water heat pump capacity or have 2 times the cubic feet size of the dwelling that you are trying to heat (includes basement if heated).
- B. The average water depth should be at least 4 feet and there should be an area where the water depth is at least 12 to 15 feet deep.

**FIGURE 12
CLEANING WATER COIL**

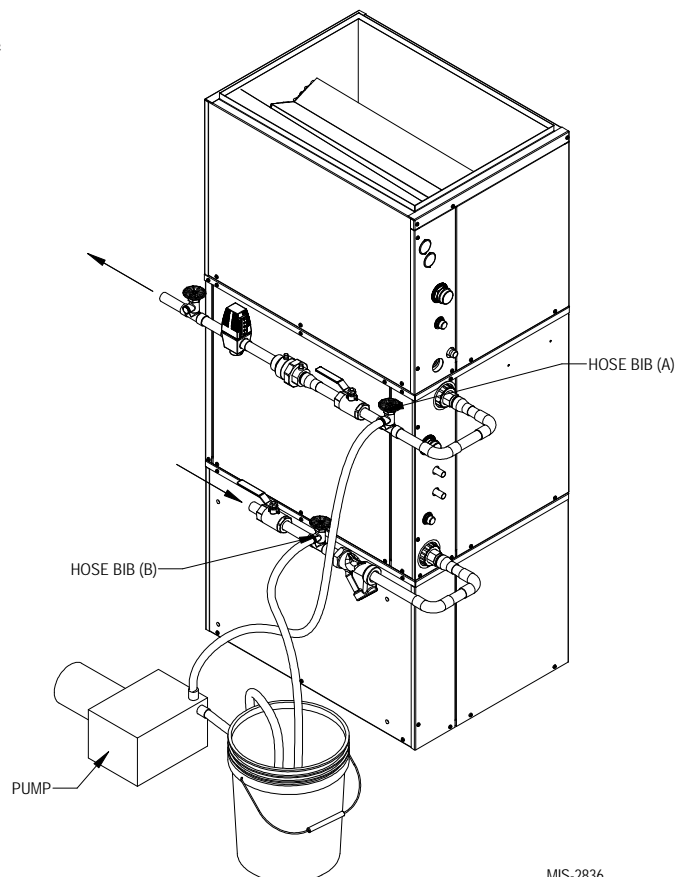

MIS-2836

- C. If possible, use a submersible pump suspended in the dry well casing. Jet pumps and other types of suction pumps normally consume more electrical energy than similarly sized submersible pumps. Pipe the unit the same as a water well system.
- D. Size the pump to provide necessary GPM for the ground water heat pump. A 12 GPM or greater water flow rate is required on all models when used on this type system.
- E. A pressure tank should be installed in dwelling to be heated adjacent to the ground water heat pump. A pressure switch should be installed at the tank for pump control.
- F. All plumbing should be carefully sized to compensate for friction losses, etc., particularly if the pond or lake is over 200 feet from the dwelling to be heated or cooled.
- G. Keep all water lines below low water level and below the frost line.
- H. Most installers use 4-inch field tile (rigid plastic or corrugated) for water return to the lake or pond.
- I. The drain line discharge should be located at least 100 feet from the dry well location.
- J. The drain line should be installed with a slope of 2 inches per 10 feet of run to provide complete drainage of the line when the ground water heat pump is not operating. This gradient should also help prevent freezing of the discharge where the pipe terminates above the frost line.
- K. Locate the discharge high enough above high water level so the water will not back up and freeze inside the drain pipe.
- L. Where the local conditions prevent the use of a gravity drainage system to a lake or pond, you can instead run standard plastic piping out into the pond below the frost and low water level.

	<h1 style="margin: 0;">WARNING</h1>
<p>Thin ice may result in the vicinity of the discharge line.</p>	

For complete information on water well systems and lake and pond applications, refer to Manual 2100-078 available from your distributor.

**FIGURE 13
LAKE OR POND INSTALLATION**

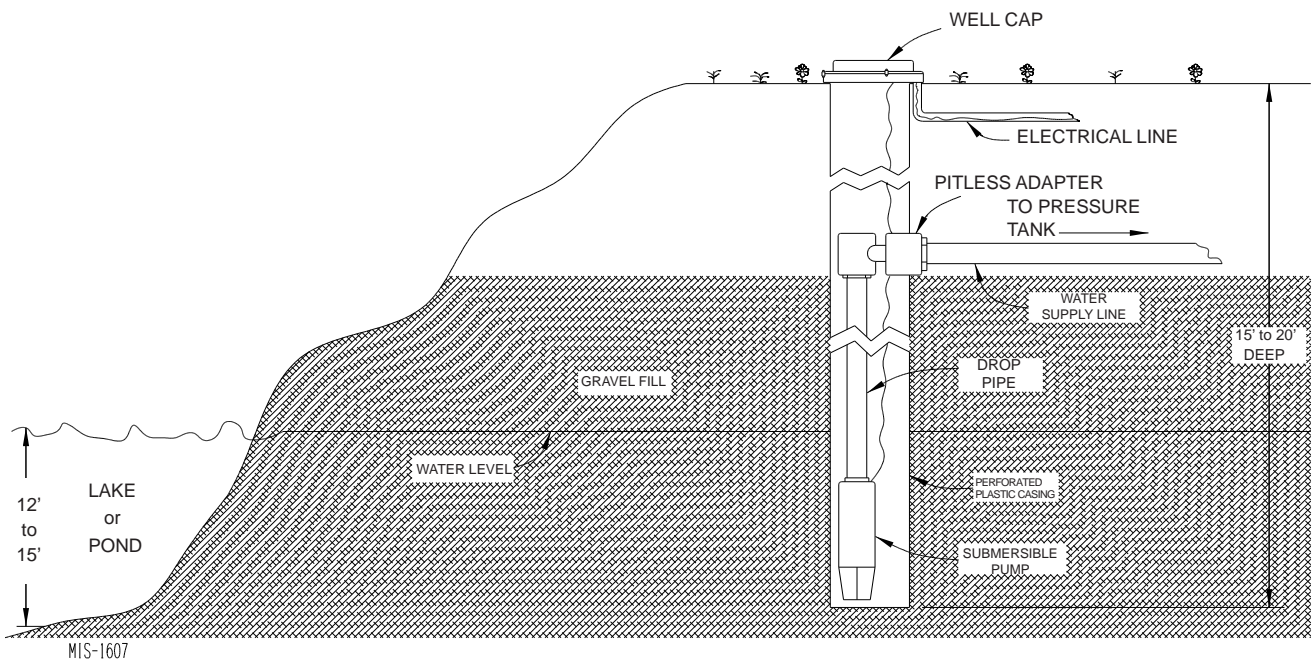

DESUPERHEATER

DESCRIPTION

The system is designed to heat domestic water using heat recovered from a water source unit's hot discharge gas.

LOCATION

Because of potential damage from freezing or condensation, the unit must be located in a conditioned space, therefore the unit must be installed indoors.

Locate the storage tank as close to the geothermal heat pump and pump module as the installation permits. Keep in mind that water lines should be a maximum of 25 feet long measured one way. Also, the vertical lift should not exceed 20 feet. This is to keep pressure and heat losses to a minimum.

ELECTRICAL CONNECTION

The Desuperheater:

The desuperheater logic control with the remote thermal sensors are built already hard-wired into the unit control panel. 208/230-60-1 power for the desuperheater pump is supplied with the same power as the compressor. The 24 volt signals needed are also tied in with the compressor call signals.



WARNING

Never alter or plug factory installed pressure relief valve on water heater or auxiliary tank.

INSTALLATION PROCEDURE – GENERAL

Before beginning the installation, turn off all power supplies to the water heater and unit, and shut off the main water supply line.

TWO TANK – In order to realize the maximum energy savings from the heat recovery system, it is recommended that a second water storage tank be installed in addition to the main hot water heater. Fossil fuel fired water heaters must be a two-tank installation.

Tanks specifically intended for hot water storage are available from water heater manufacturers (solar hot water storage tanks). A well insulated electric water heater without the electric heating elements will also make a suitable storage tank.

The size of storage tank should be as large as space and economy permit but in no event should it be less than one-half of the daily water requirements for the occupants. As a guide in estimating the daily family water requirements, The Department of Energy recommends a figure of 16.07 gallons of hot water per day per individual. For example, a family of four would require 64.3 gallons per day (4 x 16.07).

ONE TANK – The single hot water tank may be a new hot water heater (sized to 100% of daily water requirements) or the existing water heater in the case of a retrofit installation. The existing water heater should be drained and flushed to remove *all* loose sediment. This sediment could damage the circulating pump. The bottom heating element should be disconnected.

NOTE: Make sure water heater thermostats are set below 125° on One Tank Unit.

WATER PIPING – All water piping must adhere to all state and local codes. Refer to piping diagrams for recommended one and two tank installations. Piping connections are 1/2 inch nominal copper plumbing.

A cleanable “Y” type strainer should also be included to collect any sediment.

OPERATION OF THE HEAT RECOVERY UNIT

The pump module is a very simple device containing basic controls and a circulating pump. Heat is transferred from the hot refrigerant (discharge gas) to the cool water.

The operation of the Desuperheater Pump Module is controlled first by the operation of the Geothermal Heat Pump and secondly by internal controls within the Pump Module. A low voltage signal from Thermostat “Y” is connected to the desuperheater control board and acts as the primary on/off switch for the circulating pump.

Also connected to this board is a temperature overlimit device which shuts down the desuperheater once inlet water has exceeded 125° so the water cannot create a scald condition.

There are also two (2) thermistor sensors connected to the control board. These thermistors are measuring and controlling to ensure there is a positive heat differential across the water being circulated. When operating in Part Load Condition, there are certain conditions (Ground Loop Temperatures versus Hot Water Temperatures) that potential exists where heat could transfer from the hot water into the refrigeration system instead of the refrigeration system into the hot water. Through the control board logic, these thermistors ensure there is at least 2° positive differential between entering/leaving water temperatures and will shut down the pump accordingly.

START UP AND CHECK OUT

Be sure all *shut off* valves are open and all power supplies are on. Open a hot water faucet to permit any air to bleed from the plumbing.

NOTE: The inherent design of this pump for maximum efficiency means this pump is not self-priming. It is imperative to check that the air has been adequately bled from the system. There is a bleed-port built into the pump module that can be utilized after the system water has been fully restored. The bleed port is located directly above the pump in the GTC compressor unit.

Turn ON the air conditioning system and verify the circulating pump will operate. Feel the “Water to Unit” and “Water from Water Heater” tubes for noticeable difference in temperature. Turn OFF the system and verify that the circulating pump stops.

*NOTE: When checking the refrigerant operating pressures of the ground source heat pump. The desuperheater **must be** turned off. With the desuperheater operating a wide variance in pressures can result, giving the service technician the indication there is a charge problem when the unit is operating correctly.*

MAINTENANCE

CLEANING THE HEAT EXCHANGER – If scaling of the coil is strongly suspected, the coil can be cleaned with a solution of phosphoric acid (food grade acid). Follow the manufacturer’s directions for the proper mixing and use of cleaning agent.

**FIGURE 14
WIRING DIAGRAM**

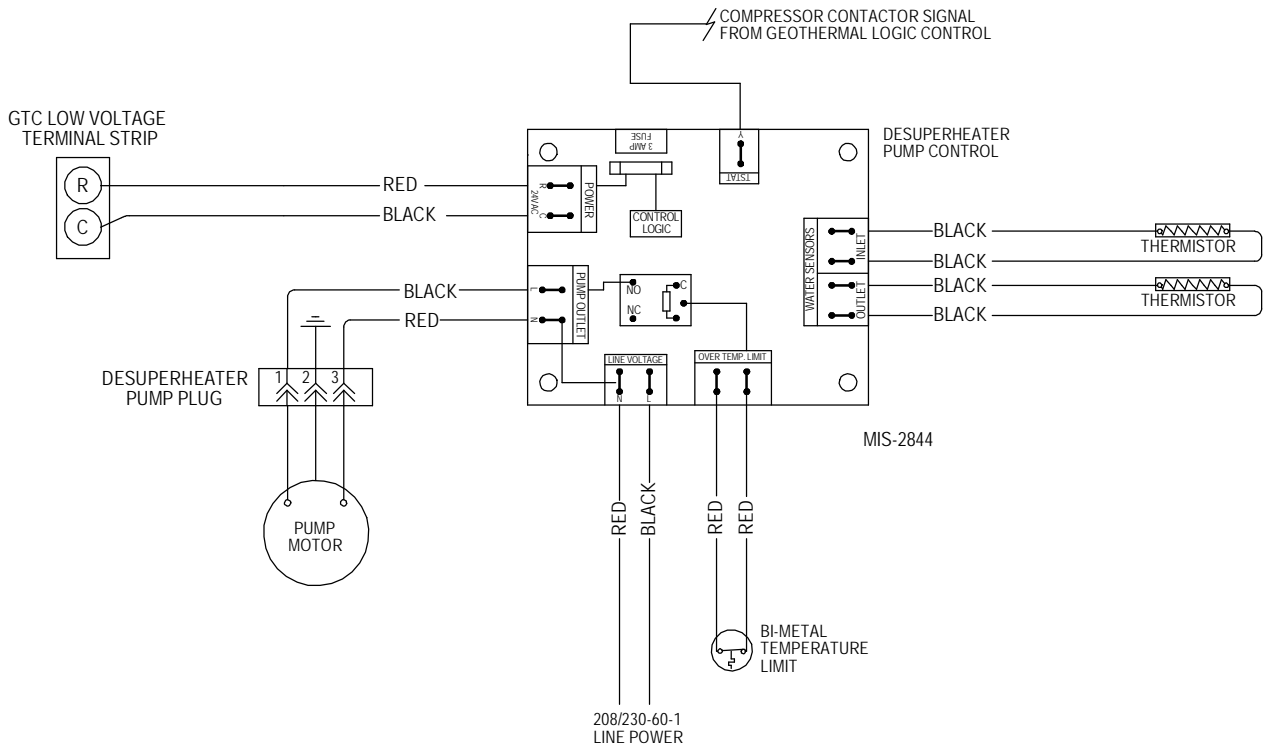
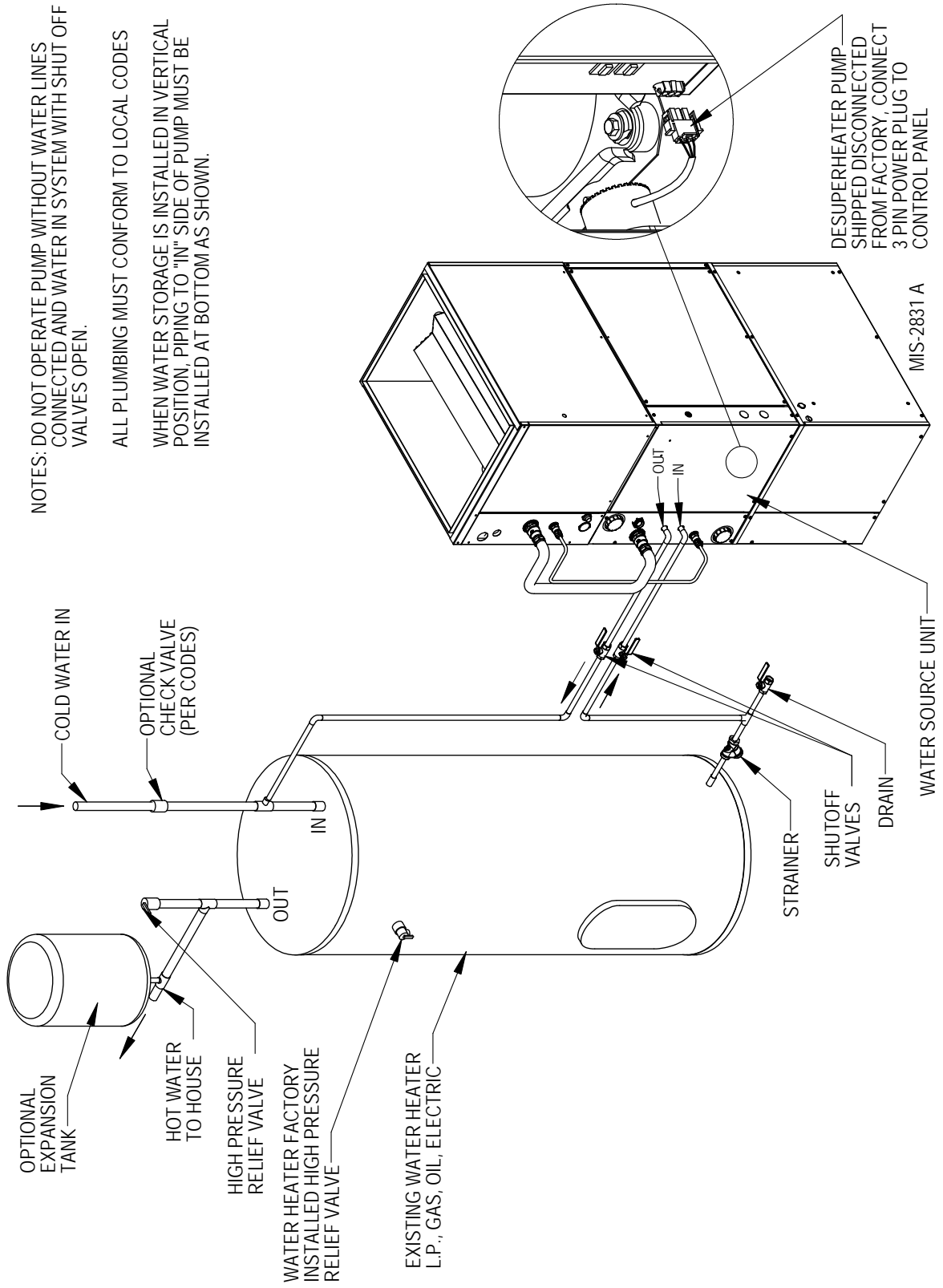

FIGURE 15A – DESUPERHEATER SINGLE TANK SYSTEM



NOTES: DO NOT OPERATE PUMP WITHOUT WATER LINES CONNECTED AND WATER IN SYSTEM WITH SHUT OFF VALVES OPEN.

ALL PLUMBING MUST CONFORM TO LOCAL CODES

WHEN WATER STORAGE IS INSTALLED IN VERTICAL POSITION, PIPING TO "IN" SIDE OF PUMP MUST BE INSTALLED AT BOTTOM AS SHOWN.

FIGURE 15B – DESUPERHEATER DUAL TANK SYSTEM

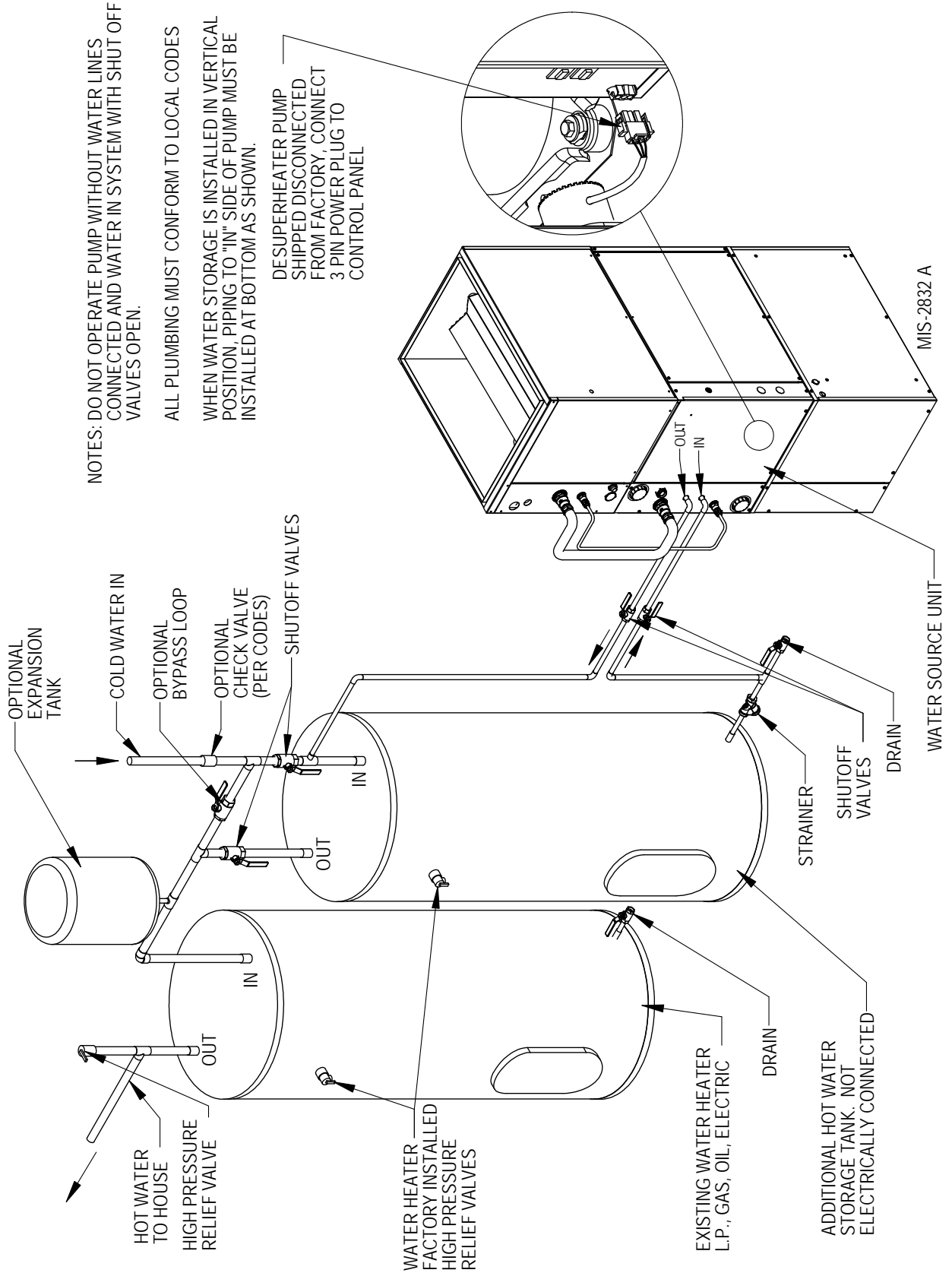

NOTES: DO NOT OPERATE PUMP WITHOUT WATER LINES CONNECTED AND WATER IN SYSTEM WITH SHUT OFF VALVES OPEN.

ALL PLUMBING MUST CONFORM TO LOCAL CODES

WHEN WATER STORAGE IS INSTALLED IN VERTICAL POSITION, PIPING TO "IN" SIDE OF PUMP MUST BE INSTALLED AT BOTTOM AS SHOWN.

DESUPERHEATER PUMP SHIPPED DISCONNECTED FROM FACTORY, CONNECT 3 PIN POWER PLUG TO CONTROL PANEL

MIS-2832 A

DESUPERHEATER CONTROL BOARD SEQUENCE OF OPERATION

The desuperheating control board will make a determination whether or not to energize the pump relay inclusive on the control board.

- A. It will constantly monitor inputs from two temperature sensors, Inlet & Outlet water sensors.
- B. It will constantly monitor the Y signal.
- C. Upon acknowledgment of Y signal, and following two minutes, the control board will energize the pump relay.
- D. After 1½ minutes, based on temperature difference between Outlet & Inlet sensors, and the presence of Y signal, the following will take place:

- 1.) If temperature difference is greater than 3°F, then the control will continue to energize pump relay.
- 2.) If temperature difference is less than 3°F, then the control will de-energize the pump relay.
- 3.) The control will next wait for 10 minutes before repeating Step #1 (above).

E. The Over Temperature Limit Switch is placed in series with the line voltage. Therefore, continuity between L of line voltage and L of pump output is forced broken when the Over Temperature Limit Switch opens (see Wiring Diagram).

F. The 3-amp fuse is put in series with the R connection to the board. Whenever the fuse is blown, the control will lose power and consequently, the relay will disengage.

Figure 16 — THERMISTOR

TEMPERATURE F VS RESISTANCE R OF TEMPERATURE SENSOR

F	R		F	R
53.0	19374		89.0	7507
52.0	18867		90.0	7334
53.0	18375		91.0	7165
54.0	17989		92.0	7000
55.0	17434		93.0	6840
56.0	16984		94.0	6683
57.0	16547		95.0	6531
58.0	16122		96.0	6383
59.0	15710		97.0	6239
60.0	15310		98.0	6098
61.0	14921		99.0	5961
62.0	14544		100.0	5827
63.0	14177		101.0	5697
64.0	13820		102.0	5570
65.0	13474		103.0	5446
66.0	13137		104.0	5326
67.0	12810		105.0	5208
68.0	12492		106.0	5094
69.0	12183		107.0	4982
70.0	11883		108.0	4873
71.0	11591		109.0	4767
72.0	11307		110.0	4663
73.0	11031		111.0	4562
74.0	10762		112.0	4464
75.0	10501		113.0	4367
76.0	10247		114.0	4274
77.0	10000		115.0	4182
78.0	9760		116.0	4093
79.0	9526		117.0	4006
80.0	9299		118.0	3921
81.0	9077		119.0	3838
82.0	8862		120.0	3757
83.0	8653		121.0	3678
84.0	8449		122.0	3601
85.0	8250		123.0	3526
86.0	8057		124.0	3452
87.0	7869			
88.0	7686			

SEQUENCE OF OPERATION

BLOWER

Blower functions are all controlled through 24 VAC input signals from the control thermostat and 208/230 VAC being supplied to the motor continuously.

The installer must be sure to configure the tap select control board (located in blower compartment) based upon the specific model application. By default, the tap select control (located in the blower compartment), is shipped from the factory to operate at the airflow ranges for the GTC60S2 model. Please see Wiring Diagram (Page 53) which details the required dip switch changes required between models.

NOTE 1: On a call from only “G” from the thermostat (call for manual fan), the blower will operate at a significantly reduced airflow rate to allow for air circulation and filtration, but at reduced power consumption and sound levels.

NOTE 2: There are $\pm 10\%$ adjustments that are enabled on the tap select control that will allow you to increase or decrease the air volume plus or minus 10%. Increasing the air volume may help with some slightly increased capacity and increased duct velocity if there is an air distribution issue. Decreasing the air volume will help improve latent capacity in a humid application, and will help to lower air distribution sound levels. Please see Wiring Diagram (Page 53) which details the required dip switch changes for this adjustment.

PART LOAD COOLING

When thermostat system switch is placed in COOL, it completes a circuit from “R” to “O”, energizing the reversing valve solenoid. On a call for cooling, the thermostat completes a circuit from “R” to “Y1” sending the signal to both the Tap Select Control located in the blower section and to the Geothermal Logic Control located in the compressor section. The tap select control uses the input signal versus the motor program, and the dip switch settings to determine the proper air volume rate to operate. The Geothermal Logic Control verifies that the High Pressure Switch, the Low Pressure Switch, and the Freeze Stat controls are all in the “closed” position. It then energizes the “A” terminal output to start the flow center (Ground Loop Applications) or energizes the water solenoid (Ground Water/Water Loop Applications). Following 10 seconds of the “A” terminal energization, the compressor contactor is energized.

FULL LOAD COOLING

The system should already be in Part Load Cooling operation prior to Full Load Cooling being energized. Additionally what happens, the thermostat completes a circuit from “R” to “Y2”. This sends a signal to both the staging solenoid on the side of the compressor, and sends a signal to the Blower Tap Select Control in the blower compartment to drive the blower to the proper CFM.

PART LOAD HEATING (No Electric Heat)

When thermostat system is placed in HEAT, the reversing valve solenoid is no longer energized. On a call for part load heating, the thermostat completes a call from “R” to “Y1” sending the signal to both the Tap Select Control located in the blower compartment, and to the Geothermal Logic Control located in the compressor section. The tap select control uses the input signal versus the motor program, and the dip switch settings to determine the proper air volume rate to operate. The Geothermal Logic Control verifies that the High Pressure Switch, the Low Pressure Switch, and the Freeze Stat controls are all in the “closed” position. It then energizes the “A” terminal output to start the flow center (Ground Loop Applications) or energizes the water solenoid (Ground Water/Water Loop Applications.) Following 30 seconds of the “A” terminal energization, the compressor contactor is energized (ensuring “WSD” jumper is installed on the geothermal logic controller).

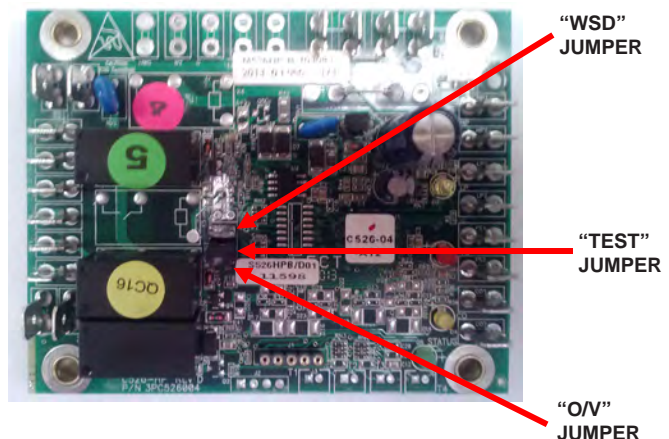

FULL LOAD HEATING

The system should already be in Part Load Heating operation prior to Full Load Heating being energized. Additionally what happens, the thermostat completes a circuit from “R” to “Y2”. This sends a signal to both the staging solenoid on the side of the compressor, and sends a signal to the Blower Tap Select Control in the blower compartment to drive the blower to the proper CFM.

SUPPLEMENTARY ELECTRIC HEAT

The system should already be in FULL LOAD HEATING operation (above). The thermostat completes a circuit from “R” to “W2”, which energizes the first bank of electric heat.

GEOTHERMAL LOGIC CONTROL

If the controller operates in normal mode, the green Status LED blinks. This indicates that 24 volt power is applied to the board and the controller is running in normal operation.

On initial power up and call for compressor operation, a 5-minute delay + a random start delay of 0 to 60-second is applied. After the random delay, the compressor relay is energized (Terminals CC & CCG). When the “Y” input opens the compressor de-energizes.

Water Solenoid – When “Y” signal is sent to Geothermal Logic Control, the water solenoid output “A” terminal will energize 10 seconds prior to “CC” output that starts compressor.

Anti-Short Cycle Timer – After compressor shutdown, or power disruption, a 5-minute timer is applied and prevents the compressor from operating.

HIGH PRESSURE SWITCH

(TERMINALS HP1 & HP2) Circuit will be proved as “closed” prior to energizing “A” or “CC” terminals. If pressure switch opens, compressor will go into soft lockout mode and compressor operation will be terminated; green fault light illuminated. Logic control will then go through 5-minute delay on break + random start sequence. If no fault found on next run cycle, compressor will continue operation. If fault reoccurs, hard lockout occurs, and fault signal is sent to “L” terminal.

LOW PRESSURE SWITCH

(TERMINALS LP1 & LP2) Circuit will be proved as “closed” prior to energizing “A” or “CC” terminals. The conditions of the LP terminals will then be ignored for the first 90 seconds after a demand for compressor operation. Following this 90 second period, if pressure switch opens, compressor will go into soft lockout mode and compressor operation will be terminated; orange fault light illuminated. The control board will then go through a 5-minute delay on break + random start sequence. If no fault found on next run cycle, compressor will continue operation. If fault reoccurs, hard lockout occurs, and fault signal is sent to “L” terminal.

FREEZE STAT (Optional Field Add-On Option)

(TERMINALS FS & FS2) Circuit will be proved as “closed” prior to energizing “A” or “CC” terminals. If freezestat switch opens, compressor will go into soft lockout mode and compressor operation will be terminated; red fault light illuminated. Logic control will then go through 5-minute delay on break + random start sequence. If no fault found on next run cycle, compressor will continue operation. If fault reoccurs, hard lockout occurs, and fault signal is sent to “L” terminal.

NOTE: Jumper wire is factory installed.

CONDENSATE OVERFLOW

(Terminals CO & CO₂) This input operates when the water level in the condensation pan rises and completes a signal across the terminals of the terminal block located in the indoor coil drain pan; yellow fault light illuminates. If fault clears, the logic control will go through 5-minute delay + random start. If fault reoccurs, or didn't clear the first time after 30 seconds, the control will go into hard lockout, and will energize the “L” output signal.

UNDER & OVER VOLTAGE PROTECTION

When an under or over voltage condition exists, the controller locks out the unit. When condition clears, the controller automatically releases the unit to normal operation and the compressor restarts after the random start and anti-short cycle timings are met. The under & over voltage protection starts at plus or minus 20% from nominal voltage and returns to operation at plus or minus 10% from nominal voltage. All four (4) LED fault lights will flash when an under or over voltage condition occurs. The over voltage protection can be disabled by removing the O/V jumper.

INTELLIGENT RESET

The Geothermal Logic Control has an intelligent reset feature after a safety control is activated. The controller locks out the unit for 5 minutes, at the end of this period, the controller checks to verify that all faults have been cleared. If faults have been cleared, the controller restarts the unit. If a second fault occurs, the controller will lock out the unit until the unit is manually reset by breaking “Y” signal from thermostat. The last fault will be kept in memory after a full lockout; this is only cleared by cycling the power.

ALARM OUTPUT

The “L” terminal has 24 volts applied when a hard lockout occurs. This can be used to drive a fault light or a low voltage relay.

PRESSURE SERVICE PORTS

High and low pressure service ports are installed on all units so that the system operating pressures can be observed. Pressure tables can be found later in the manual covering all models. It is imperative to match the correct pressure table to the unit by model number.

SYSTEM START-UP

- Step 1 – Close disconnect switch(es) and set the thermostat to cool and the temperature to the highest setting.
- Step 2 – Check for proper airflow across the indoor coil.
- Step 3 – Connect the service gauges and allow the unit to run for at least 10 minutes or until pressures are stable. Check pressures to the system pressure table attached to the unit service panel.
- Step 4 – Fill out Ground Source Heat Pump Performance Report.

FIGURE 17 — COMPONENT LOCATION

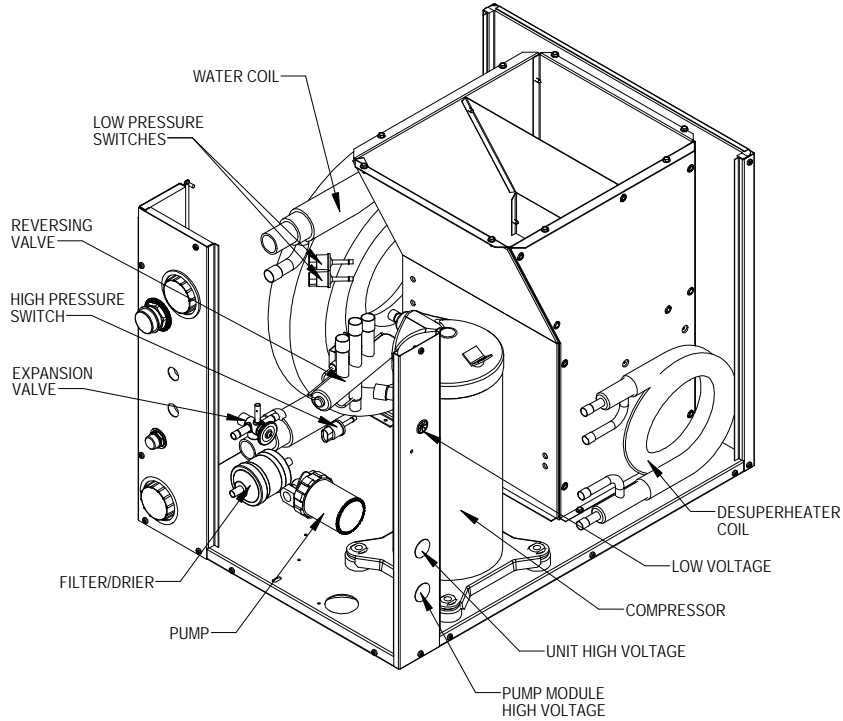

MIS-2838

FIGURE 18 — CONTROL PANEL

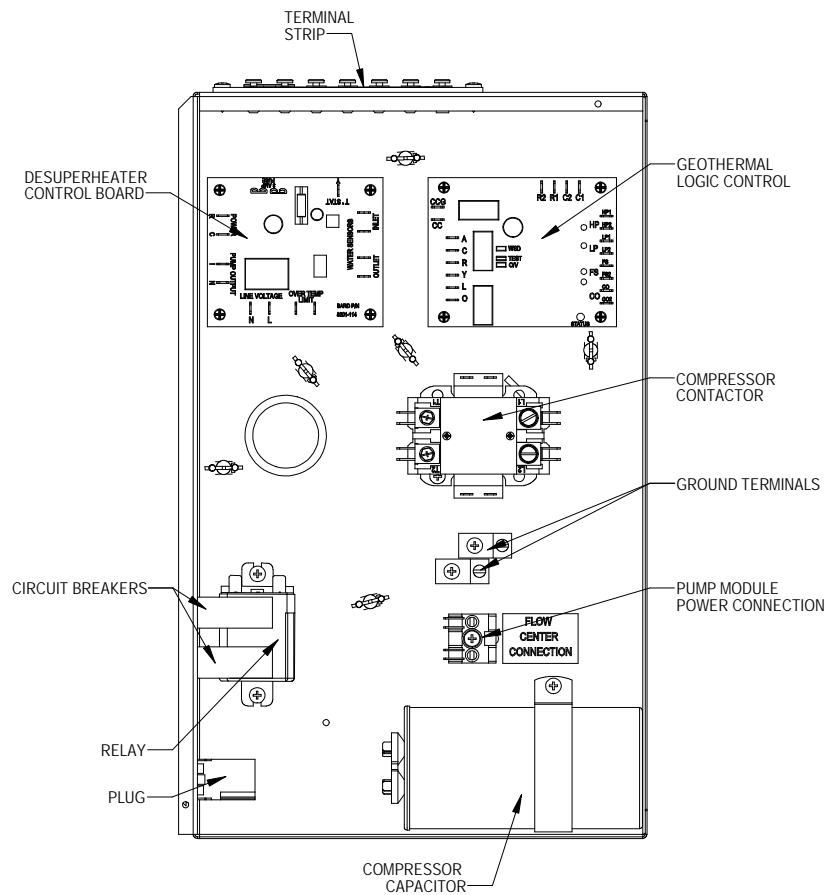

MIS-2837

FIGURE 19

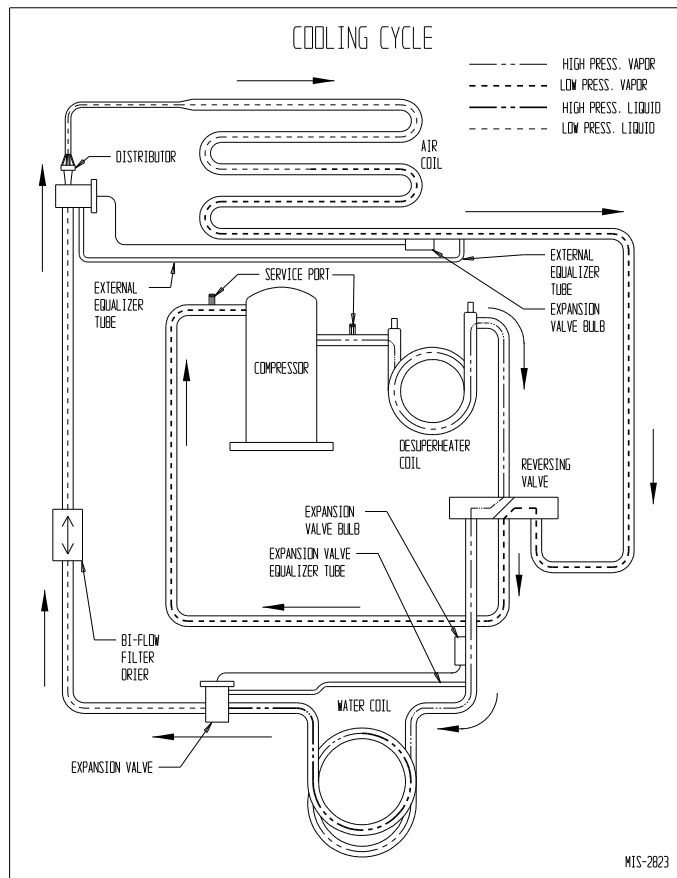
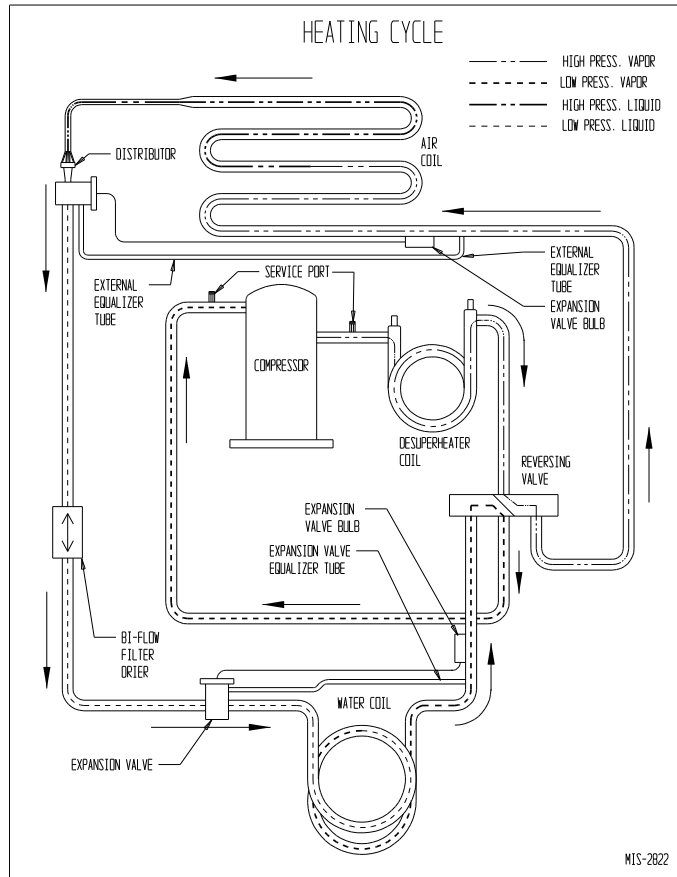

REFRIGERANT CHARGE

LINE SET INSTALLATION – GTA COIL SECTIONS

CHARGE ADJUSTMENT

All supplied line sets with threaded refrigerant connections are factory evacuated and charged with R-410A refrigerant at the quantity required to optimize system performance. Refer to Table 9 to see this charge quantity if you need to reprocess the charge due to repairing damage or replacement of a defective component.

For those using Stub Kits GTLS-SK2-1 or GTLS-SK4-1, you will first need to braze up both ends of your line set (to the point that it is sealed). Ports are provided on the GTLS-SK*-1 kits so that you can pull a vacuum on the line set and pre-charge with refrigerant before screwing on the refrigerant fittings onto the pre-charged condenser and evaporator (if using one with threaded connectors).

For charge quantity, use Table 9 as a good general reference to the required R-410A refrigerant required based upon your line set length. Or, you can specifically measure your line set length, and add 1.4 ounces of R-410A refrigerant per 1' of line set length.

REFRIGERANT FITTING ATTACHMENT

1. Coat all mating surface, including o-rings, with R-410A refrigerant oil (Polyol Ester).
2. Attach female fittings to coil/condensing unit portion by hand-threading initially. **Be careful not to cross-thread assembly.** For the pre-manufactured 3' line set used with a vertical (stacked) configuration, the fittings should be threaded simultaneously. Again, **be careful not to cross-thread either assembly.**

3. Final torque should be achieved. Use the appropriate size wrench in conjunction with a second (backing) wrench to ensure that fittings do not spin or twist on the copper refrigerant lines. Use the following torque rates:

3/8" Lineset – 22-25 ft. lbs. (30-35 Nm)

7/8" Lineset – 44-47 ft. lbs. (60-65 Nm)

CHECKING REFRIGERANT CHARGE QUANTITY – GTA COIL SECTIONS

The correct R-410A charge is shown on the unit rating plate (including adders for the various line set lengths). Reference Figure 21 to validate proper system operation. However, it is recommended that if incorrect charge is suspected, the system refrigerant be reclaimed, evacuated, and charged to nameplate charge quantity and type (including necessary charge adjustment for the installed line set length).

The nameplate charge quantity is optimized for thermal performance and efficiency throughout all modes of operation.

**TABLE 9
PRE-CHARGED LINE SET REFRIGERANT QUANTITY**

MODEL	DESCRIPTION	R-410A CHARGE QUANTITY (Ounces)		
		3/8" Line	7/8" Line	Total
GTLS-03-1	3' Line Set	1.2	3	4.2
GTLS-15-1	15' Line Set	6	15	21
GTLS-25-1	25' Line Set	10	25	35
GTLS-35-1	35' Line Set	14	35	49
GTLS-50-1	50' Line Set	20	50	70

REFRIGERANT CHARGE

GENERAL – GTADP COIL SECTIONS

GENERAL (GTADP Add-On Coils)

These instructions are intended as a general guide and do not supersede the coil manufacturer's installation instructions or local codes in any way. **Read the manufacturer's installation manual and all "WARNING" statements prior to installing the evaporator coil.**

The following is needed, in addition to the evaporator coil.

1. Line Set Stub Kit with Single Pair Ends – Bard Part No. GTLS-SK2-1
2. Line Set consisting of 7/8" and 3/8" soft rolled copper with insulation.
3. Coil Spacer (Oil Furnaces Only)

Coils are shipped with a 10 PSIG dry air holding charge. Puncture rubber plug on suction line to release charge before removing plugs. The absence of pressure does not verify a leak. Check the coil for leaks prior to installing if a leak is suspected.

Position the coil/box directly on top of a gas furnace and secure using sheet metal screws. The drain pans are made of a polymer that can withstand temperatures up to 450°F. **If installed on an oil or drum type heat exchanger (a coil spacer is recommended to) maintain a 6 inch clearance to protect the pan and to provide optimum air flow over the coil.** Coil should be level, or pitched slightly toward the drain connections. See Figure 20.

LINE SET INSTALLATION (GTADP Add-On Coils)

Braze up one end of the line set to the GTLS-SK2-1 stub kit and the other end to the evaporator coil. Ports are provided in the GTLS-SK2-1 kit. Pull a vacuum (100 microns) on the line set and coil. Pre-charge the line set and coil with refrigerant before screwing the refrigerant fittings onto the pre-charged condenser section.

REFRIGERANT CHARGE QUANTITY – Line Set and Evaporator Coil (GTADP Add-On Coils)

The refrigerant charge shown on the GTC condenser section is based on being matched with a GTA coil section and not the ADP "A" coil. Charge adjustments are required for proper system operation when using an ADP coil. Use the following formulas to determine the amount of charge required.

- $GTC36 \text{ Line Set Charge} = \text{Line Set Length (FT)} \times 1.4 \text{ oz. R-410A/FT} - 3.0 \text{ oz.}$
- $GTC48 \text{ Line Set Charge} = \text{Line Set Length (FT)} \times 1.4 \text{ oz. R-410A/FT} - 9.0 \text{ oz.}$
- $GTC60 \text{ Line Set Charge} = \text{Line Set Length (FT)} \times 1.4 \text{ oz. R-410A/FT} + 20.0 \text{ oz.}$

Example:

A GTC48 condenser section is being installed with a GTADP-4860-C evaporator coil and a 25 foot line set.

$GTC48 \text{ Line Set Charge} = \text{Line Set Length } 25 \text{ (FT)} \times 1.4 \text{ oz. R-410A/FT} - 9.0 \text{ oz.}$

$GTC48 \text{ Line Set Charge} = 26.0 \text{ oz.}$

DO NOT CONNECT THE LINE SET TO THE CONDENSER SECTION

Pre-charge the line set and evaporator coil with the amount of R-410A calculated earlier.

REFRIGERANT FITTING ATTACHMENT (After pre-charging line set & coil) (GTADP Add-On Coils)

1. Coat all mating surfaces, including o-rings, with R-410A refrigerant oil (Polyol Ester).
2. Attach female fittings to condensing unit portion by hand-threading initially. **Be careful not to cross-thread assembly.**
3. Final torque should be achieved. Use the appropriate size wrench in conjunction with a second (backing) wrench to ensure that the fittings do not spin or twist on the copper refrigerant lines. Use the following torque rates:

3/8" Line Set: 22-25 ft. lbs. (30-35 Nm)

7/8" Line Set: 44-47 ft. lbs. (60-65 Nm)

**FIGURE 20
COIL SPACER**

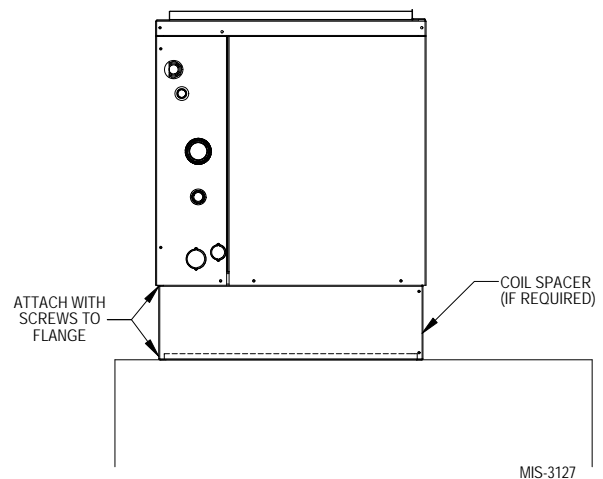

REFRIGERANT CHARGE

These units require R-410A refrigerant and Polyol Ester.

GENERAL:

1. Use separate service equipment to avoid cross contamination of oil and refrigerants.
2. Use recovery equipment rated for R-410A refrigerant.
3. Use manifold gauges rated for R-410A (800 psi/250 psi low).
4. R-410A is a binary blend of HFC-32 and HFC-125.
5. R-410A is nearly azeotropic - similar to R-22 and R-12. Although nearly azeotropic, charge with liquid refrigerant.
6. R-410A operates at 40-70% higher pressure than R-22, and systems designed for R-22 cannot withstand this higher pressure.
7. R-410A has an ozone depletion potential of zero, but must be reclaimed due to its global warming potential.
8. R-410A compressors use Polyol Ester.
9. Polyol Ester oil is hygroscopic; it will rapidly absorb moisture and strongly hold this moisture in the oil.
10. A liquid line dryer must be used - even a deep vacuum will not separate moisture from the oil.
11. Limit atmospheric exposure to 15 minutes.
12. If compressor removal is necessary, always plug compressor immediately after removal. Purge with small amount of nitrogen when inserting plugs.

TOPPING OFF SYSTEM CHARGE

If a leak has occurred in the system, reclaiming, evacuating (see criteria above), and charging to the nameplate charge is recommended.

Topping off the system charge can be done without problems. With R-410A, there are no significant changes in the refrigerant composition during multiple leaks and recharges. R-410A refrigerant is close to being an azeotropic blend (it behaves like a pure compound or single component refrigerant). The remaining refrigerant charge, in the system, may be used after leaks have occurred and then “top-off” the charge by utilizing the charging charts on the inner control panel cover as a guideline.

REMEMBER: When adding R-410A refrigerant, it must come out of the charging cylinder/tank as a liquid to avoid any fractionation, and to insure optimal system performance. Refer to instructions for the cylinder that is being utilized for proper method of liquid extraction.

SAFETY PRACTICES:

1. Never mix R-410A with other refrigerants.
2. Use gloves and safety glasses, Polyol Ester oils can be irritating to the skin, and liquid refrigerant will freeze the skin.
3. Never use air and R-410A to leak check; the mixture may become flammable.
4. Do not inhale R-410A – the vapor attacks the nervous system, creating dizziness, loss of coordination and slurred speech. Cardiac irregularities, unconsciousness and ultimate death can result from breathing this concentration.
5. Do not burn R-410A. This decomposition produces hazardous vapors. Evacuate the area if exposed.
6. Use only cylinders rated DOT4BA/4BW 400.
7. Never fill cylinders over 80% of total capacity.
8. Store cylinders in a cool area, out of direct sunlight.
9. Never heat cylinders above 125°F.
10. Never trap liquid R-410A in manifold sets, gauge lines or cylinders. R-410A expands significantly at warmer temperatures. Once a cylinder or line is full of liquid, any further rise in temperature will cause it to burst.

**FIGURE 21
PRESSURE TABLES**

Model	Return Air Temperature	Pressure	FULL LOAD COOLING — Fluid Temperature Entering Water Coil °F																
			30°F	35°F	40°F	45°F	50°F	55°F	60°F	65°F	70°F	75°F	80°F	85°F	90°F	95°F	100°F	105°F	110°F
GTC36S2	75° DB 62° WB	Low Side High Side	108 148	111 163	113 177	116 192	118 206	121 221	123 235	126 250	128 264	129 286	129 309	130 331	131 353	131 376	132 398	132 420	133 442
	80° DB 67° WB	Low Side High Side	116 152	118 167	121 182	124 196	126 211	129 226	132 241	134 256	137 271	138 294	138 317	139 340	140 362	140 385	141 408	141 431	142 454
	85° DB 72° WB	Low Side High Side	124 157	127 173	130 188	133 203	136 219	139 234	142 250	144 265	147 280	148 304	149 328	149 351	150 375	151 399	152 422	152 446	153 470
GTC48S2	75° DB 62° WB	Low Side High Side	109 148	111 162	113 176	115 191	117 205	119 220	121 234	122 249	124 263	125 285	127 306	128 328	129 349	130 371	131 392	132 413	133 435
	80° DB 67° WB	Low Side High Side	117 151	119 166	121 181	123 196	125 211	127 226	129 240	131 255	133 270	134 292	135 314	137 336	138 358	139 380	140 402	141 424	142 446
	85° DB 72° WB	Low Side High Side	126 157	128 172	130 187	132 203	134 218	137 233	139 249	141 264	143 279	144 302	145 325	147 348	148 371	149 393	151 416	152 439	153 462
GTC60S2	75° DB 62° WB	Low Side High Side	116 139	117 154	117 169	117 183	117 198	118 213	118 228	118 243	119 257	120 278	122 298	123 318	125 338	127 358	128 378	130 398	131 419
	80° DB 67° WB	Low Side High Side	124 143	125 158	125 173	125 188	126 203	126 219	126 234	127 249	127 264	129 285	130 305	132 326	134 347	135 367	137 388	139 409	140 429
	85° DB 72° WB	Low Side High Side	134 148	134 163	134 179	135 195	135 210	135 226	135 242	136 258	137 273	138 295	140 316	142 337	144 359	145 380	147 402	149 423	151 444
Model	Return Air Temperature	Pressure	FULL LOAD HEATING — Fluid Temperature Entering Water Coil °F																
			5°F	10°F	15°F	20°F	25°F	30°F	35°F	40°F	45°F	50°F	55°F	60°F	65°F	70°F	75°F	80°F	85°F
GTC36S2	70° DB	Low Side High Side	45 242	52 252	59 262	66 272	72 282	79 292	86 302	93 312	99 322	106 332	117 342	129 353	140 363	151 373	162 383	174 394	185 404
GTC48S2	70° DB	Low Side High Side	36 247	44 258	52 270	60 281	68 293	76 304	84 316	92 327	100 339	108 350	119 361	129 372	140 383	150 394	161 405	171 416	182 427
GTC60S2	70° DB	Low Side High Side	38 264	46 273	54 282	62 292	70 301	78 310	86 319	94 329	102 338	110 347	118 357	126 366	134 376	142 385	150 395	158 404	166 414
Model	Return Air Temperature	Pressure	PART LOAD COOLING — Fluid Temperature Entering Water Coil °F																
			30°F	35°F	40°F	45°F	50°F	55°F	60°F	65°F	70°F	75°F	80°F	85°F	90°F	95°F	100°F	105°F	110°F
GTC36S2	75° DB 62° WB	Low Side High Side	116 130	119 144	121 159	123 173	126 188	128 202	130 216	133 231	135 245	135 265	135 284	135 303	135 322	135 341	136 360	136 379	136 398
	80° DB 67° WB	Low Side High Side	124 133	127 148	129 163	132 177	134 192	137 207	139 222	142 237	144 252	144 271	145 291	145 310	145 330	145 349	145 369	145 389	145 408
	85° DB 72° WB	Low Side High Side	134 138	136 153	139 168	142 184	144 199	147 214	150 230	153 245	155 261	155 281	155 301	156 321	156 341	156 362	156 382	156 402	156 422
GTC48S2	75° DB 62° WB	Low Side High Side	119 131	121 146	123 160	125 174	127 189	129 203	132 217	134 231	136 246	137 266	137 287	138 308	139 328	140 349	141 370	142 390	143 411
	80° DB 67° WB	Low Side High Side	128 135	130 149	132 164	134 179	136 193	139 208	141 223	143 237	145 252	146 273	147 294	148 316	149 337	150 358	151 379	152 400	153 421
	85° DB 72° WB	Low Side High Side	137 139	140 155	142 170	144 185	147 200	149 215	151 230	154 246	156 261	157 283	158 305	159 327	160 348	161 370	162 392	163 414	164 436
GTC60S2	75° DB 62° WB	Low Side High Side	127 122	127 137	127 152	127 167	128 182	128 197	128 212	129 227	129 242	130 262	131 282	131 302	132 322	133 342	134 362	134 382	135 402
	80° DB 67° WB	Low Side High Side	135 125	136 141	136 156	136 171	137 187	137 202	137 217	138 233	138 248	139 269	140 289	141 310	141 330	142 351	143 371	144 392	145 412
	85° DB 72° WB	Low Side High Side	145 130	146 146	146 161	147 177	147 193	147 209	148 225	148 241	148 257	149 278	150 299	151 320	152 342	153 363	154 384	155 405	156 426
Model	Return Air Temperature	Pressure	PART LOAD HEATING — Fluid Temperature Entering Water Coil °F																
			5°F	10°F	15°F	20°F	25°F	30°F	35°F	40°F	45°F	50°F	55°F	60°F	65°F	70°F	75°F	80°F	85°F
GTC36S2	70° DB	Low Side High Side	23 238	35 247	46 256	57 264	68 273	80 288	91 296	102 305	111 317	120 328	131 337	143 346	154 354	165 363	176 372	188 381	199 389
GTC48S2	70° DB	Low Side High Side	20 228	31 238	43 247	54 257	66 266	77 281	89 291	100 300	109 311	117 322	129 332	140 341	152 351	163 360	175 370	186 379	198 389
GTC60S2	70° DB	Low Side High Side	27 236	38 247	48 257	58 268	68 278	79 294	89 305	99 315	109 326	119 336	129 347	140 357	150 368	160 378	170 389	181 399	191 410

LOW SIDE PRESSURE +/- 2 PSIG
HIGH SIDE PRESSURE +/- 5 PSIG

Tables based upon rated CFM (airflow) across the evaporator coil.

If incorrect charge suspected (more than ±2 psig suction, ±5 psig liquid), it is recommended refrigerant charge be reclaimed, system evacuated and charged to serial plate quantity.

QUICK REFERENCE TROUBLESHOOTING CHART FOR WATER TO AIR HEAT PUMP

• Denotes common cause
 + Denotes occasional cause

	POWER SUPPLY														WATER COIL SECTION														INDOOR SECTION								AUX.																				
	Line Voltage				Control Circuit				Compressor						Refrigerant System						Water Solenoid Valve		Water Coil				Indoor Blower Motor and Coil				Heat Gen.																										
	Power Failure	Blown Fuse or Tripped Breaker	Faulty Wiring	Loose Terminals	Low Voltage	Defective Contacts in Contactor	Compressor Overload	Potential Relay	Run Capacitor	Start Capacitor	Faulty Wiring	Loose Terminals	Control Transformer	Low Voltage	Thermostat	Contact Coil	Pressure Controls (High or Low)	Indoor Blower Relay	Discharge Line Hitting Inside of Shell	Bearings Defective	Seized	Valve Defective	Motor Windings Defective	Refrigerant Charge Low	Refrigerant Overcharge	High Head Pressure	Low Head Pressure	High Suction Pressure	Low Suction Pressure	Non-Condensables	Unequalized Pressures	Solenoid Valve Stuck Closed (Cig)	Solenoid Valve Stuck Open (Htg or Cig)	Leaking	Defective Valve or Coil	Plugged or Restricted Metering Device (Htg)	Plugged or Restricted Metering Device (Cig)	Fins Dirty or Plugged	Motor Winding Defective	Air Volume Low	Air Filters Dirty	Undersized or Restricted Ductwork	Auxiliary Heat Upstream of Coil														
Compressor Will Not Run	•	•	•	•	•	•	•	•	•	•	•	•	•	•	•	•	•																																								
No Power at Contactor		•	•	•	•	•	•	•	•																																																
Compressor Will Not Run Power at Contactor		•	•	•	•	•	•	•	•																																																
Compressor "Hums" But Will Not Start		•	•	•	•	•	•	•	•																																																
Compressor Cycles on Overload																																																									
Thermostat Check Light																																																									
Lite-Lockout Relay																																																									
Compressor Off on High Pressure Control																																																									
Compressor Off on Low Pressure Control																																																									
Compressor Noisy																																																									
Head Pressure Too High																																																									
Head Pressure Too Low																																																									
Suction Pressure Too High																																																									
Suction Pressure Too Low																																																									
I.D. Blower Will Not Start																																																									
I.D. Coil Frosting or Icing																																																									
High Compressor Amps																																																									
Excessive Water Usage																																																									
Compressor Runs Continuously – No Cooling																																																									
Liquid Refrigerant Flooding Back To Compressor																																																									
Compressor Runs Continuously – No Heating																																																									
Reversing Valve Does Not Shift																																																									
Liquid Refrigerant Flooding Back To Compressor																																																									
Aux. Heat on I.D. Blower Off																																																									
Excessive Operation Costs																																																									
Ice in Water Coil																																																									

SERVICE HINTS

1. Caution owner to maintain clean air filters at all times. Also, not to needlessly close off supply and return air registers. This reduces airflow through the system, which shortens equipment service life as well as increasing operating costs.
2. Check all power fuses or circuit breakers to be sure that they are the correct rating.

UNBRAZING SYSTEM COMPONENTS

If the refrigerant charge is removed from a scroll equipped unit by bleeding the high side only, it is sometimes possible for the scrolls to seal, preventing pressure equalization through the compressor. This may leave low side shell and suction line tubing pressurized. If the brazing torch is then applied to the low side while the low side shell and suction line contains pressure, the pressurized refrigerant and oil mixture could ignite when it escapes and contacts the brazing flame. To prevent this occurrence, it is important to check both the high and low side with manifold gauges before unbrazing.

ECM MOTOR

This unit is equipped with an ECM motor. It is important that the blower motor plugs are not plugged in or unplugged while the power is on. Failure to remove power prior to unplugging or plugging in the motor could result in motor failure.



WARNING

Both the high and low side of the scroll compressor must be checked with manifold gauges before unbrazing system components. Failure to do so could cause pressurized refrigerant and oil mixture to ignite if it escapes and contacts the brazing flame causing property damage, bodily harm or death.



CAUTION

Do not plug in or unplug blower motor connectors while the power is on. Failure to do so may result in motor failure.

COMPRESSOR SOLENOID

(See Sequence of Operation on Pages 37 & 38 for function.)

A nominal 24-volt direct current coil activates the internal compressor solenoid. The input control circuit voltage must be 18 to 28 volts ac. The coil power requirement is 20 VA. The external electrical connection is made with a molded plug assembly. This plug contains a full wave rectifier to supply direct current to the unloader coil.

Compressor Solenoid Test Procedure – If it is suspected that the unloader is not working, the following methods may be used to verify operation.

1. Operate the system and measure compressor amperage. Cycle the compressor solenoid on and off at 10-second intervals. The compressor amperage should go up or down at least 25 percent.
2. If step one does not give the expected results, shut unit off. Apply 18 to 28 volts ac to the solenoid molded plug leads and listen for a click as the solenoid pulls in. Remove power and listen for another click as the solenoid returns to its original position.
3. If clicks can't be heard, shut off power and remove the control circuit molded plug from the compressor and measure the solenoid coil resistance. The resistance should be 32 to 60 ohms depending on compressor temperature.
4. Next, check the molded plug.

Voltage check: Apply control voltage to the plug wires (18 to 28 volts ac). The measured **dc** voltage at the female connectors in the plug should be around 15 to 27 vdc.

Resistance check: Measure the resistance from the end of one molded plug lead to either of the two female connectors in the plug. One of the connectors should read close to zero ohms, while the other should read infinity. Repeat with other wire. The same female connector as before should read zero, while the other connector again reads infinity. Reverse polarity on the ohmmeter leads and repeat. The female connector that read infinity previously should now read close to zero ohms.

Replace plug if either of these test methods does not show the desired results.

TROUBLESHOOTING GE ECM 2.3™ MOTORS

CAUTION:

Disconnect power from unit before removing or replacing connectors, or servicing motor. To avoid electric shock from the motor's capacitors, disconnect power and wait at least 5 minutes before opening motor.

Symptom

Motor rocks slightly when starting

Motor won't start

- No movement

- Motor rocks, but won't start

Motor oscillates up load & down while being tested off of blower

Motor starts, but runs erratically

- Varies up and down or intermittent

- "Hunts" or "puffs" at high CFM (speed)

- Stays at low CFM despite system call for cool or heat CFM

- Stays at high CFM

- Blower won't shut off

Excessive noise

- Air noise

Cause/Procedure

- This is normal start-up for ECM

- Check blower turns by hand
- Check power at motor
- Check low voltage (24 Vac R to C) at motor
- Check low voltage connections (G, Y, W, R, C) at motor
- Check for unseated pins in connectors on motor harness
- Test with a temporary jumper between R - G
- Check motor for tight shaft
- Perform motor/control replacement check
- **Perform Moisture Check**

- Check for loose or compliant motor mount
- Make sure blower wheel is tight on shaft
- Perform motor/control replacement check

- It is normal for motor to oscillate with no on shaft

- Check line voltage for variation or "sag"
- Check low voltage connections (G, Y, W, R, C) at motor, unseated pins in motor harness connectors
- Check "Bk" for erratic CFM command (in variable-speed applications)
- Check out system controls, Thermostat
- **Perform Moisture Check**

- Does removing panel or filter reduce "puffing"?
 - Reduce restriction
 - Reduce max airflow

- Check low voltage (Thermostat) wires and connections
- Verify fan is not in delay mode; wait until delay complete
- "R" missing/not connected at motor
- Perform motor/control replacement check

- "R" missing/not connected at motor
- Is fan in delay mode? - wait until delay time complete
- Perform motor/control replacement check

- Current leakage from controls into G, Y or W? Check for Triac switched thermostat or solid-state relay

- Determine if it's air noise, cabinet, duct or motor noise; interview customer, if necessary
- High static creating high blower speed?
 - Is airflow set properly?
 - Does removing filter cause blower to slow down? Check filter
 - Use low-pressure drop filter
 - Check/correct duct restrictions

Symptom

- Noisy blower or cabinet

- "Hunts" or "puffs" at high CFM (speed)

Evidence of Moisture

- Motor failure or malfunction has occurred and moisture is present
- Evidence of moisture present inside air mover

Do

- Check out motor, controls, wiring and connections thoroughly before replacing motor
- Orient connectors down so water can't get in
 - Install "drip loops"
- Use authorized motor and model #'s for replacement
- Keep static pressure to a minimum:
 - Recommend high efficiency, low static filters
 - Recommend keeping filters clean.
 - Design ductwork for min. static, max. comfort
 - Look for and recommend ductwork improvement, where necessary

- Size the equipment wisely
- Check orientation before inserting motor connectors

Moisture Check

- Connectors are oriented "down" (or as recommended by equipment manufacturer)
- Arrange harness with "drip loop" under motor
- Is condensate drain plugged?
- Check for low airflow (too much latent capacity)
- Check for undercharged condition
- Check and plug leaks in return ducts, cabinet

Comfort Check

- Check proper airflow settings
- Low static pressure for lowest noise
- Set low continuous-fan CFM
- Use humidistat and 2-speed cooling units
- Use zoning controls designed for ECM that regulate CFM
- Thermostat in bad location?

Cause/Procedure

- Check for loose blower housing, panels, etc.
- High static creating high blower speed?
 - Check for air whistling through seams in ducts, cabinets or panels
 - Check for cabinet/duct deformation

- Does removing panel or filter reduce "puffing"?
 - Reduce restriction
 - Reduce max. airflow

- Replace motor and **Perform Moisture Check**

- **Perform Moisture Check**

Don't

- Automatically assume the motor is bad.

- Locate connectors above 7 and 4 o'clock positions

- Replace one motor or control model # with another (unless an authorized replacement)
- Use high pressure drop filters some have 1/2" H2O drop!
- Use restricted returns

- Oversize system, then compensate with low airflow
- Plug in power connector backwards
- Force plugs

TROUBLESHOOTING GE ECM™ MOTORS CONT'D.

Replacing ECM Control Module

To replace the control module for the GE variable-speed indoor blower motor you need to take the following steps:

1. You **MUST** have the correct replacement module. The controls are factory programmed for specific operating modes. Even though they look alike, different modules may have completely different functionality.

USING THE WRONG CONTROL MODULE VOIDS ALL PRODUCT WARRANTIES AND MAY PRODUCE UNEXPECTED RESULTS.

2. Begin by removing AC power from the unit being serviced. **DO NOT WORK ON THE MOTOR WITH AC POWER APPLIED.** To avoid electric shock from the motor's capacitors, disconnect power and wait at least 5 minutes before opening motor.

3. It is not necessary to remove the motor from the blower assembly, nor the blower assembly from the unit. Unplug the two cable connectors to the motor control assembly. There are latches on each connector. **DO NOT PULL ON THE WIRES.** The plugs remove easily when properly released.

4. Locate the screws that retain to the motor control bracket to the sheet metal of the unit and remove them. Remove two (2) nuts that retain the control to the bracket and then remove two (2) nuts that retain sheet metal motor control end plate. Refer to Figure 22.

5. Disconnect the three (3) wires interior of the motor control by using your thumb and forefinger squeezing the latch tab and the opposite side of the connector plug, gently pulling the connector. **DO NOT PULL ON THE WIRES, GRIP THE PLUG ONLY.** Refer to Figure 22.

6. The control module is now completely detached from the motor. Verify with a standard ohmmeter that the resistance from each motor lead (in the motor plug just removed) to the motor shell is $>100\text{K}$ ohms. Refer to Figure 23. (Measure to unpainted motor end plate.) If any motor lead fails this test, do not proceed to install the control module. **THE MOTOR IS DEFECTIVE AND MUST BE REPLACED.** Installing the new control module will cause it to fail also.

7. Verify that the replacement control is correct for your application. Refer to the manufacturer's authorized replacement list. **USING THE WRONG CONTROL WILL RESULT IN IMPROPER OR NO BLOWER OPERATION.** Orient the control module so that the 3-wire motor plug can be inserted into the socket in the control. Carefully insert the plug and press it into the socket until it latches. **A SLIGHT CLICK WILL BE HEARD WHEN PROPERLY INSERTED.**

8. Reverse the steps #5, 4, 3 to reconnect the motor control to the motor wires, securing the motor control cover plate, mounting the control to the bracket, and mounting the motor control bracket back into the unit. **MAKE SURE THE ORIENTATION YOU SELECT FOR REPLACING THE CONTROL ASSURES THE CONTROL'S CABLE CONNECTORS WILL BE LOCATED DOWNWARD IN THE APPLICATION SO THAT WATER CANNOT RUN DOWN THE CABLES AND INTO THE CONTROL. DO NOT OVERTIGHTEN THE BOLTS.**

9. Plug the 16-pin control plug into the motor. The plug is keyed. Make sure the connector is properly seated and latched.

10. Plug the 5-pin power connector into the motor. Even though the plug is keyed, **OBSERVE THE PROPER ORIENTATION. DO NOT FORCE THE CONNECTOR.** It plugs in very easily when properly oriented. **REVERSING THIS PLUG WILL CAUSE IMMEDIATE FAILURE OF THE CONTROL MODULE.**

11. Final installation check. Make sure the motor is installed as follows:

a. Motor connectors should be oriented between the 4 o'clock and 8 o'clock positions when the control is positioned in its final location and orientation.

b. Add a drip loop to the cables so that water cannot enter the motor by draining down the cables. Refer to Figure 24.

The installation is now complete. Reapply the AC power to the HVAC equipment and verify that the new motor control module is working properly. Follow the manufacturer's procedures for disposition of the old control module.

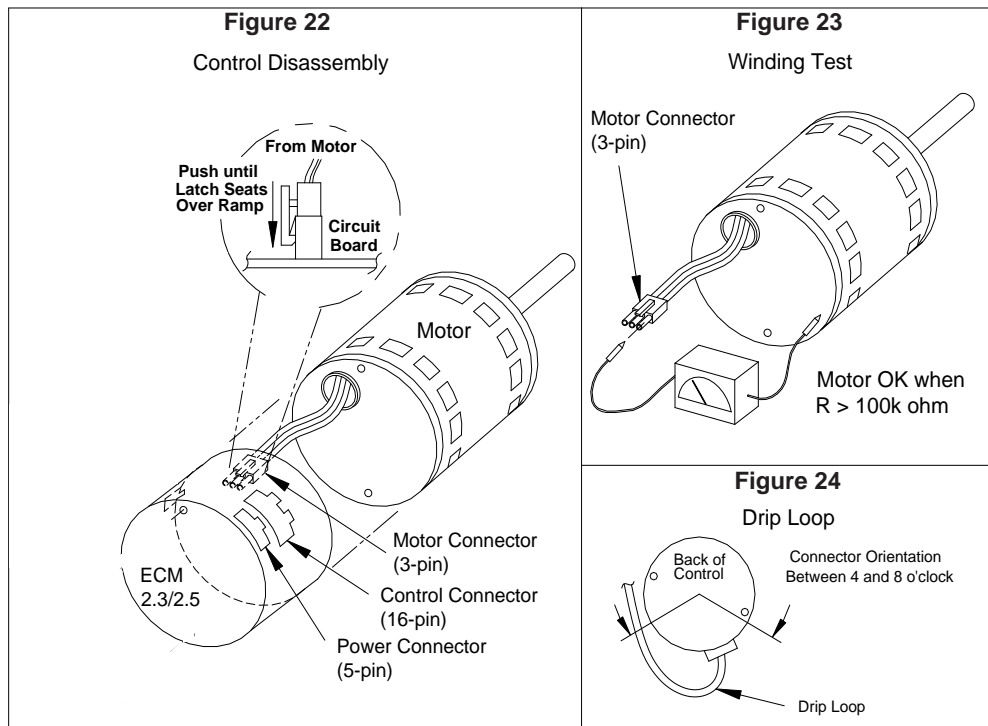

TROUBLESHOOTING GE ECM™ MOTORS CONT'D.

MODE of OPERATION	OFF	Continuous Blower	Part Load Cooling	Full Load Cooling	Part Load Heating	Full Load Heating	Full Load Heating + Electric Heat Stage #1	Emergency Heat Mode
Thermostat 24 VAC Inuput Signals	—	"G"	"G", "Y1", "O"	"G", "Y1", "Y2", "O"	"G", "Y1"	"G", "Y1", "Y2"	"G", "Y1", "Y2", "W1"	"G", "E", "W1", "W2"
Pin #1	24 VAC "C" (Common) Signal, Always Energized							
Pin #2							X	X
Pin #3	24 VAC "C" (Common) Signal, Always Energized							
Pin #4	Delay Tap Profiles, Varied Half-Wave Signals Based Upon Settings							
Pin #5	Cool Tap Select Tables, Varied Half-Wave Signals Based Upon Settings (Tonnage)							
Pin #6			X	X	X	X	X	
Pin #7	Adjustment Tap Profiles, Varied Half-Wave Signals Based Upon Settings							
Pin #8	DC Volts "-" Output in Direct Correlation to CFM							
Pin #9			X	X				
Pin #10	Future Use; Not Currently Programmed for Function							
Pin #11	Heat Tap Select Tables, Varied Half-Wave Signals Based Upon Tonnage							
Pin #12	24 VAC Hot "R" Signal, Always Energized							
Pin #13								X
Pin #14				X		X		
Pin #15		X	X	X	X	X	X	X
Pin #16	DC Volts "+" Output in Direct Correlation to CFM							

**FIGURE 25
CONTROL CONNECTOR MOTOR HALF**

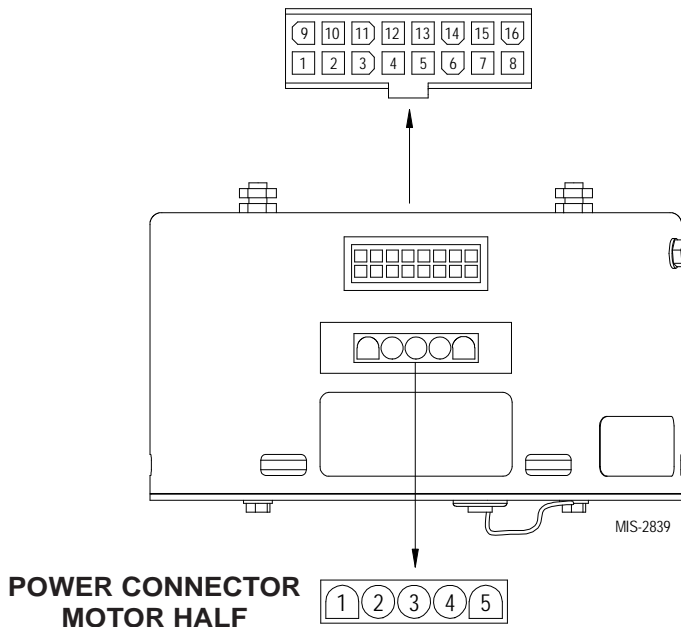

POWER CONNECTOR *	
PWB HEADER	AMP 1-350945-0
PIN	Description
1	Jumper Pin 1 to Pin 2 for 120VAC Line Input Only **
2	
3	Chassis Ground
4	AC Line
5	AC Line

* Suggested mating connector
Housing — AMP 350809-1
Contact — AMP 350537-1

** **WARNING** — Applying 240VAC line input with PIN 1 to PIN 2 jumper in place will permanently damage unit!

GROUND SOURCE HEAT PUMP PERFORMANCE REPORT

This performance check report should be filled out by installer and retained with unit.

DATE _____ TAKEN BY: _____

1. UNIT:
Mfgr _____ Model No. _____ S/N _____

THERMOSTAT:
Mfgr _____ Model No. _____ P/N _____

2. Person Reporting _____

3. Company Reporting _____

4. Installed By _____ Date Installed _____

5. User's (Owner's) Name _____
Address _____

6. Unit Location _____

WATER SYSTEM INFORMATION

7. Open Loop System (Water Well) _____ Closed Loop System _____

A. If Open Loop where is water discharged? _____

8. The following questions are for **Closed Loop systems only**

A. Closed loop system designed by _____

B. Type of antifreeze used _____ % Solution _____

C. System type: Series _____ Parallel _____

D. Pipe material _____ Nominal Size _____

E. Pipe Installed:

1. Horizontal _____ Total length of pipe _____ ft

No. pipes in trench _____ Depth bottom pipe _____ ft

2. Vertical _____ Total length of bore hole _____ ft

THE FOLLOWING INFORMATION IS NEEDED TO CHECK PERFORMANCE OF UNIT.

FLUID SIDE DATA

		Cooling	** Heating	
9.	Entering fluid temperature	_____	_____	F
10.	Leaving fluid temperature	_____	_____	F
11.	Entering fluid pressure	_____	_____	PSIG
12.	Leaving fluid pressure	_____	_____	PSIG
13.	Pressure drop through coil	_____	_____	PSIG
14.	Gallons per minute through the water coil	_____	_____	GPM
15.	Liquid or discharge line pressure	_____	_____	PSIG
16.	Suction line pressure	_____	_____	PSIG
17.	Voltage at compressor (unit running)	_____	_____	V
18.	Amperage draw at line side of contactor	_____	_____	A
19.	Amperage at compressor common terminal	_____	_____	A
20.	* Suction line temperature 6" from compressor	_____	_____	F
21.	* Superheat at compressor	_____	_____	F
22.	* Liquid line temperature at metering device	_____	_____	F
23.	* Coil subcooling	_____	_____	F

INDOOR SIDE DATA

		Cooling	** Heating	
24.	Dry bulb temperature at air entering indoor coil	_____	_____	F
25.	Wet bulb temperature of air entering indoor coil	_____	_____	F
26.	Dry bulb temperature of air leaving indoor coil	_____	_____	F
27.	Wet bulb temperature of air leaving indoor coil	_____	_____	F
28.	* Supply air static pressure (packaged unit)	_____	_____	WC
29.	* Return air static pressure (packaged unit)	_____	_____	WC
30.	Other information about installation			

** When performing a heating test insure that 2nd stage heat is not activated
 * Items that are optional

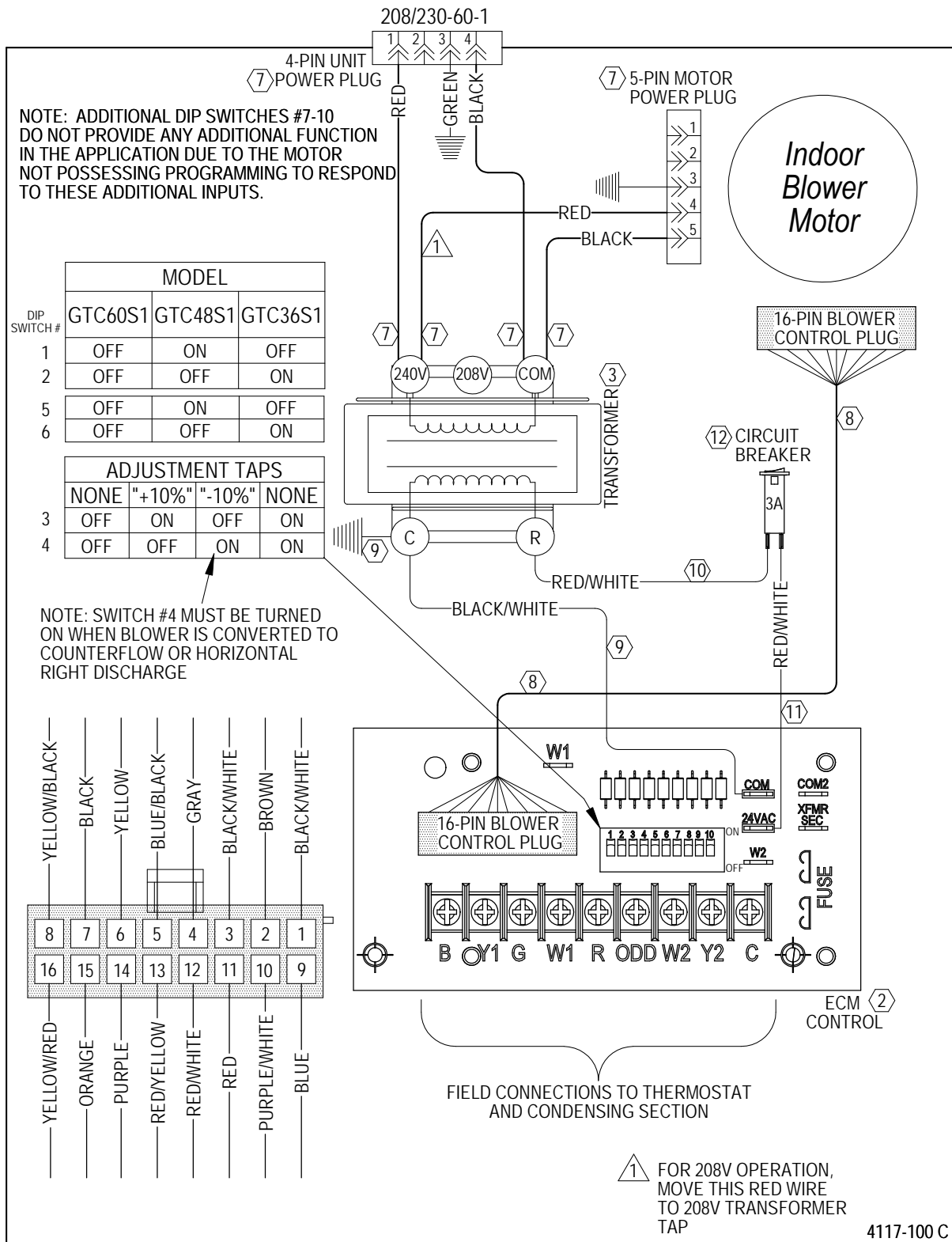

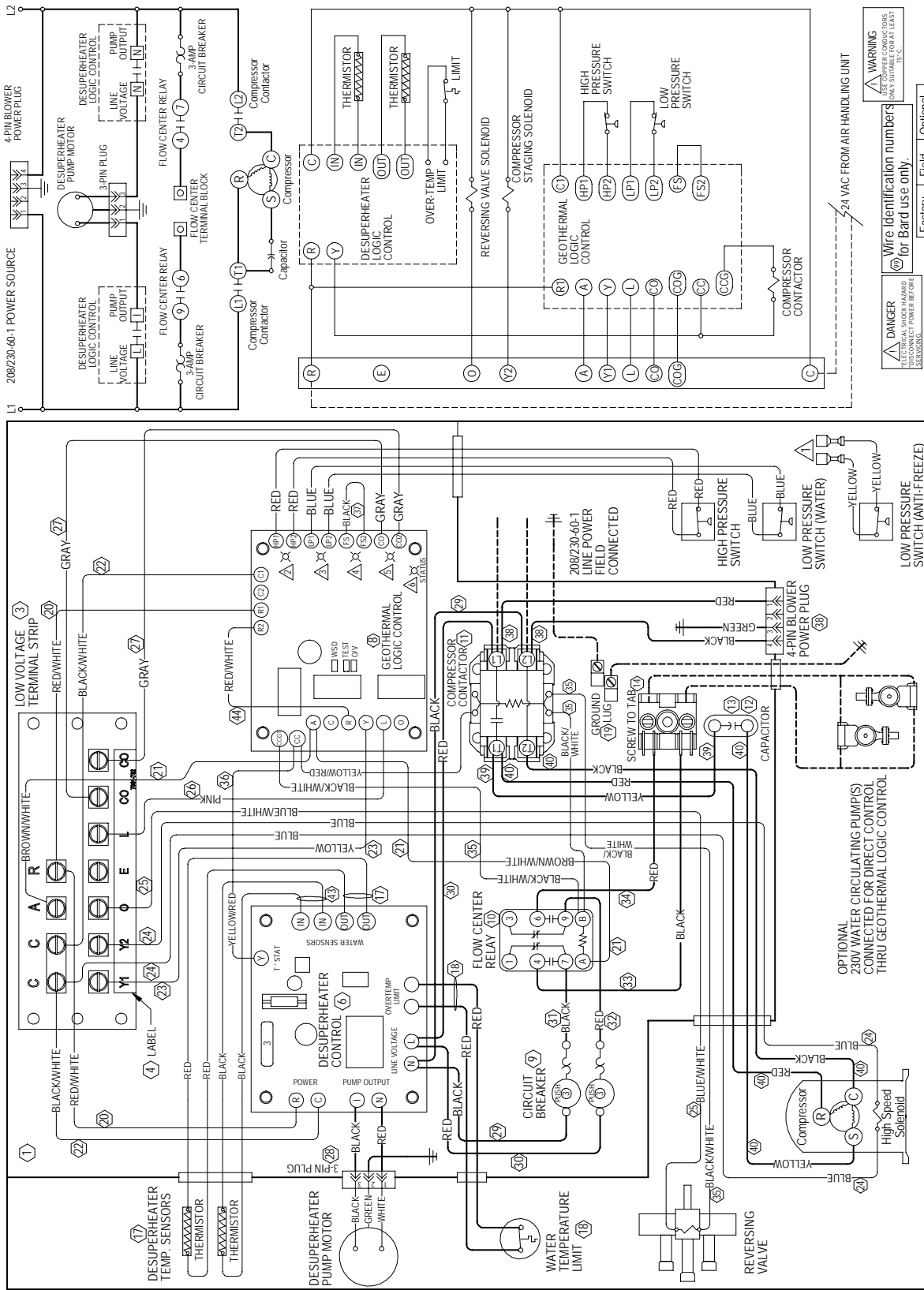

⚠️ FOR ANTI-FREEZE LOOP APPLICATIONS, CHANGE H.P.S. = Green fault light illuminated when fault indicated.
 ⚠️ LOW PRESSURE SWITCH TO YELLOW LEADS ON LPC TERMINALS OF GEOTHERMAL LOGIC CONTROL BOARD.
 ⚠️ L.P.S. = Orange fault light illuminated when fault indicated.
 ⚠️ F.S. = Red fault light illuminated when fault indicated.

⚠️ DANGER: DISCONNECT POWER BEFORE REWIRING.
 ⚠️ WARNING: THE COMPRESSOR COILS MUST BE OUT OF LEAD.

Ⓜ️ Wire Identification numbers for Bard use only.

Field	Optional
High Voltage	
Low Voltage	

4117-101.D