
OIL FURNACE INSTALLATION INSTRUCTIONS

MODELS

FC085V42A
FH110V60A
FLF110V60A
FLR110V60A

FH085V42A
FLF085V42A
FLR085V42A
FLR140V60A

FH110V48A
FLF110V48A
FLR110V48A



WARNING

READ ALL INSTRUCTIONS CAREFULLY BEFORE BEGINNING THE INSTALLATION.

THIS INSTALLATION MUST COMPLY WITH THESE INSTRUCTIONS AND THE REQUIREMENTS OF ALL GOVERNING CODES AND ORDINANCES FOR THE INSTALLATION LOCATION.

IT IS THE RESPONSIBILITY OF INSTALLER TO KNOW AND UNDERSTAND ALL OF THESE REQUIREMENTS.

FAILURE TO DO SO COULD CREATE A HAZARD RESULTING IN PROPERTY DAMAGE, BODILY INJURY OR DEATH.

FOR YOUR SAFETY

DO NOT STORE OR USE GASOLINE OR OTHER FLAMMABLE VAPORS OR LIQUIDS IN THE VICINITY OF THIS OR ANY OTHER APPLIANCE.

IMPORTANT NOTICE

THIS FURNACE IS NOT INTENDED FOR USE AS A CONSTRUCTION HEATER. USE OF THIS FURNACE DURING CONSTRUCTION AND FINISHING PHASES OF A STRUCTURE IS CONSIDERED AS "OPERATION IN A CORROSIVE ATMOSPHERE" AND "UNUSUAL, NEGLIGENT OR IMPROPER USE" AND AS SUCH ARE CONSIDERED EXCLUSIONS BY THE BARD MANUFACTURING COMPANY LIMITED WARRANTY.



WARNING

CARBON MONOXIDE POISONING HAZARD

FAILURE TO FOLLOW THIS WARNING COULD RESULT IN PERSONAL INJURY OR DEATH.

Carbon Monoxide is invisible, odorless and toxic! Bard Manufacturing recommends a carbon monoxide alarm in your home, even if you do not own a gas appliance. Locate the carbon monoxide alarm in the living area of your home and away from doorways to attached garages. Follow the alarm manufacturer's instructions included with the alarm.



CLIMATE CONTROL SOLUTIONS

Bard Manufacturing Company, Inc.
Bryan, Ohio 43506
Since 1914...Moving ahead just as planned.

Manual: 2100-540C
Supersedes: 2100-540B
File: VOL. I, TAB 3
Date: 09-28-12

CONTENTS

Getting Other Information and Publications 3

Installation and Operating Instructions

Equipment Selection	4
Locating the Furnace	4
Installing the Furnace	8
Duct Work	8
Installing a Cooling Unit	8
Wiring	9
Oil Line Piping	12
Beckett AFG Oil Burner	12 & 13
Beckett "CleanCut" Oil Pump	13
Beckett Solid State Igniter	13
Beckett GeniSys 7505	14 & 16-17
Burner States, Reset Button Op., Priming the Pump, Cad Cell Resistance Indicator, Reset Restricted Lockout	
Troubleshooting GE ECM2.3	21-23
Burner Setup and Adjustments	24-26
Short Form Adjustment Procedure	26
Combustion Air Requirements	30
Louvers and Grilles	35
Venting Options	35
Thermostat	35

TABLES

Table 1 Minimum Clearances	4
Table 2 Dimensions FLF/R Models	5
Table 3 Electrical Data	9
Table A Reset Button Operation	15
Table B Status Lights	15
Table C Heating Tap Select Settings	19
Table D Cooling Tap Select Settings	19
Table E Adjustment Tap Selects	20
Table F Heating Delay Profile Taps	20
Troubleshooting GE ECM2.3	21
Table 4 Furnace Data	24
Table 5 Correlation of % of CO ₂ , O ₂ and Reserve Air	29
Table 6 No. 2 Fuel Oil Efficiency Chart	29
Table 7 Recommended Start-Up Settings	29
Table 8 Sq.Ft. Required as Unconfined Space	32
Table 9 Minimum Ventilation Openings	33
Table 10 Temperature Rise Ranges, Limit Control Settings, and Heating Blower Speeds	36
Table 11 Filter Sizes for Oil Furnaces	37

Filters

Lo-Boy Models – Filter Locations	37-38
--	-------

Maintenance

Lubrication	39
Inspect Air Filter	39
Final Inspection and Test	39
Service Hints	39
Combination Combustion Chamber/Burner Mounting System	40
To Remove Burner Only	41
To Remove Entire Combustion Chamber Mounting System	41
Common Causes of Trouble	42
Care of Finish	42
Cleaning of the Heat Exchanger	42
Wiring Diagrams	43-45

FIGURES

Figure 1 FLF/R Models Dimensions	5
Figure 2 FH Models Dimensions	6
Figure 3 FC Models Dimensions	7
Figure 4 Typical Unit Setup - FLF	10
Figure 5 Typical Flue Installation Requirements - FLF	11
Figure 6 Typical Single Inside Tank Installation	12
Figure 7 Electronic Blower Control	18
Figure 8 Control Disassembly	23
Figure 9 Winding Test	23
Figure 10 Drip Loop	23
Figure 11 Typical Smoke-CO ₂ Characteristic ..	27
Figure 12 Pressure Gauge Connection to Bleed Port	28
Figure 13A Electrode Adjustments-AFG	30
Figure 13B Electrode Adjustments-NX	30
Figure 14 Combustion Air Boot Assembly	31
Figure 15 All Air From Inside Building	32
Figure 16 All Air From Outdoors	33
Figure 17 All Air From Outdoors Through Ventilated Attic	34
Figure 18 All Air From Outdoors - Inlet Air From Ventilated Crawl Space and Outlet Air to Ventilated Attic	34
Figure 19 Typical Installation of FR26 and FR27 . Filter Rack	37
Figure 20 Typical Installation of FR25 Filter Kit	37
Figure 21 Filter Installation - Lo-Boy Models ...	38
Figure 22 Removal of Burner Only	40
Figure 23 Removal of Entire Combustion Chamber Mounting System	41

GETTING OTHER INFORMATION and PUBLICATIONS

These publications can help you install the furnace. You can usually find these at your local library or purchase them directly from the publisher. Be sure to consult current edition of each standard.

National Fuel Gas Code ANSI Z223.1/NFPA54

National Electrical Code ANSI/NFPA 70

Standard for the Installation ANSI/NFPA 90A
of Air Conditioning and Ventilating Systems

Standard for Warm Air ANSI/NFPA 90B
Heating and Air Conditioning Systems

Standard for Chimneys, Fireplaces, Vents NFPA 211
and Solid Fuel Burning Appliances

Load Calculation for ACCA Manual J
Residential Winter and Summer Air Conditioning

Duct Design for Residential ACCA Manual D
Winter and Summer Air Conditioning
and Equipment Selection

FOR MORE INFORMATION, CONTACT THESE PUBLISHERS:

ACCA **Air Conditioning Contractors of America**
1712 New Hampshire Ave. N.W.
Washington, DC 20009
Telephone: (202) 483-9370
Fax: (202) 234-4721

ANSI **American National Standards Institute**
11 West Street, 13th Floor
New York, NY 10036
Telephone: (212) 642-4900
Fax: (212) 302-1286

ASHRAE **American Society of Heating Refrigerating,
and Air Conditioning Engineers, Inc.**
1791 Tullie Circle, N.E.
Atlanta, GA 30329-2305
Telephone: (404) 636-8400
Fax: (404) 321-5478

NFPA **National Fire Protection Association**
Batterymarch Park
P.O. Box 9101
Quincy, MA 02269-9901
Telephone: (800) 344-3555
Fax: (617) 984-7057

INSTALLATION and OPERATING INSTRUCTIONS

EQUIPMENT SELECTION

An accurate heating load calculation must be conducted using American Society of Heating, Refrigeration and Air Conditioning Engineers (ASHRAE) or Air Conditioning Contractors of America (ACCA) manuals. **Do not** add a large safety factor above the calculated value. If the calculated heating load requirement exceeds the heating capacity rating of a given model, use only the next larger size available. Never increase by any more than absolutely necessary based upon available equipment **heating capacities**. Always select based upon heat capacity (output), never use input capacities.

NOTE: It is the personal responsibility and obligation of the purchaser to contract a qualified installer to assure that installation is adequate and is in conformance with governing codes and ordinances.

LOCATING THE FURNACE

When installing the furnace be sure to provide adequate space for easy service and maintenance. Locate the furnace as close to the chimney as practical, giving consideration to the accessibility of the oil burner, controls, and blower for service. Allow a minimum of 24 inches at front of furnace for servicing oil burner. Allow adequate room for filter and blower maintenance. **Clearance from combustible material as stated on the furnace and repeated in Table 1 must be maintained.** For damp basement installations, a raised concrete pad is recommended. This will help keep the bottom of the furnace dry and reduce the risk of rusting.

An oil burner must have a generous supply of combustion air to operate properly. The flow of combustion and ventilating air must not be obstructed from reaching the furnace. See “Combustion Air Requirements” section.

The furnace area must be kept clear and free of combustible materials, gasoline and other flammable vapors and liquids.

This unit is not designed for mobile home or trailer installations. Always install furnace in a level position.

**TABLE 1
MINIMUM CLEARANCES**

Model	Minimum Installation Clearances — Inches								Minimum Service Clearances		
	Furnace			Plenum		① Duct	Flue Pipe	Floor	Front	Back	Sides
	Front	Back	Sides	Top	Sides						
FC085V42A	6	1	2	2	2	2	9	NC **	24	—	—
FH085V42A	4	1	2	2	2	2	9	C	24	—	—
FH110V48A	4	1	2	2	2	2	9	C	24	—	—
FH110V60A	4	1	2	2	2	2	9	C	24	—	—
FLF085V42A	6	0	2	2	2	2	9	NC	24	24	18 *
FLF110V48A	6	0	2	2	2	2	9	NC	24	24	18 *
FLF110V60A	6	0	2	2	2	2	9	NC	24	24	18 *
FLR085V42A	6	18	2	2	2	2	9	NC	24	24	18 *
FLR110V48A	6	18	2	2	2	2	9	NC	24	24	18 *
FLR110V60A	6	18	2	2	2	2	9	NC	24	24	18 *
FLR140V60A	6	18	2	2	2	2	9	NC	24	24	18 *

① For the first three (3) feet from plenum. After three (3) feet, no clearance required.

C Combustible flooring

NC Noncombustible floor

* Maintained on one side or the other to achieve filter access and/or blower service.

** Floor must be noncombustible. For furnace only installation can be installed on combustible flooring only when installed on special base part no. CFB7 available from factory. When air conditioning coil cabinet DCB23-22 is used then use special base part no. CFB23.

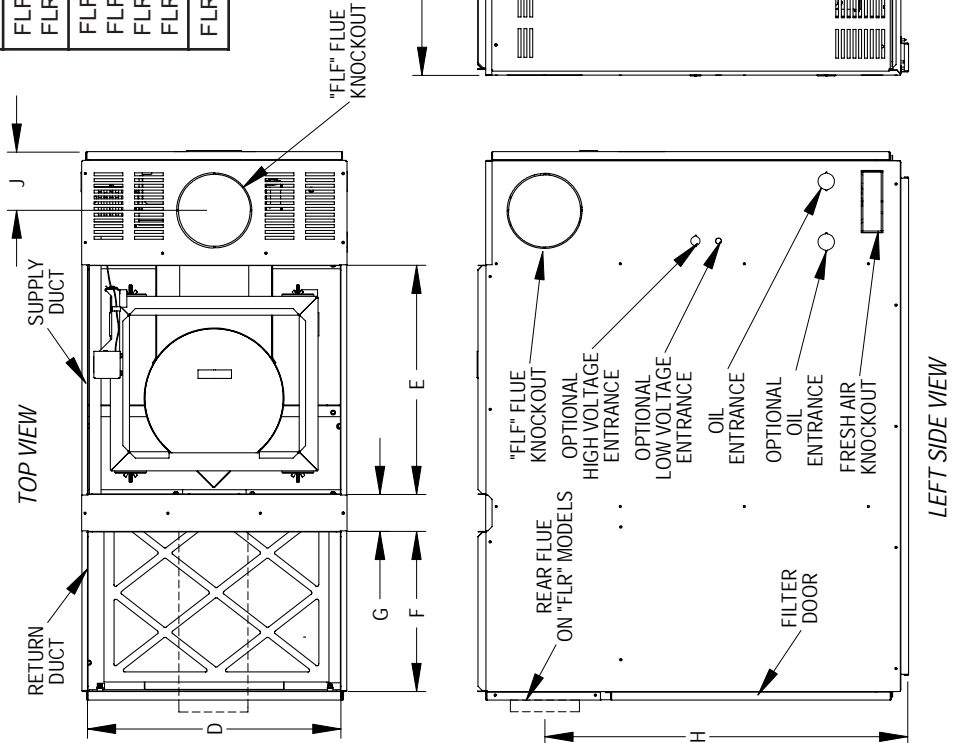
FIGURE 1
FLF/R MODELS DIMENSIONS

TABLE 2
FLF/R MODELS DIMENSIONS (INCHES)

Model Number	Cabinet		Plenum Openings		Flue Connection			Air Filters ①	
	A Width	B Depth	D x E Supply	D x F Return	Location	G Dia.	H	J	No. Used
FLF085V42A	23	48.125	22x20	22x14	Front	6	31.625	5.125	16 x 20 x 1
FLR085V42A	23	48.125	22x20	22x14	Rear	6	31.625	5.125	16 x 20 x 1
FLF110V48A	23	48.125	22x20	22x14	Front	6	35.625	5.125	20 x 20 x 1
FLF110V60A	23	48.125	22x20	22x14	Front	6	35.625	5.125	20 x 20 x 1
FLR110V48A	23	48.125	22x20	22x14	Rear	6	35.625	5.125	20 x 20 x 1
FLR110V60A	23	48.125	22x20	22x14	Rear	6	35.625	5.125	20 x 20 x 1
FLR140V60A	26	50.250	25x20	25x16	Rear	6	42.125	—	20 x 25 x 1

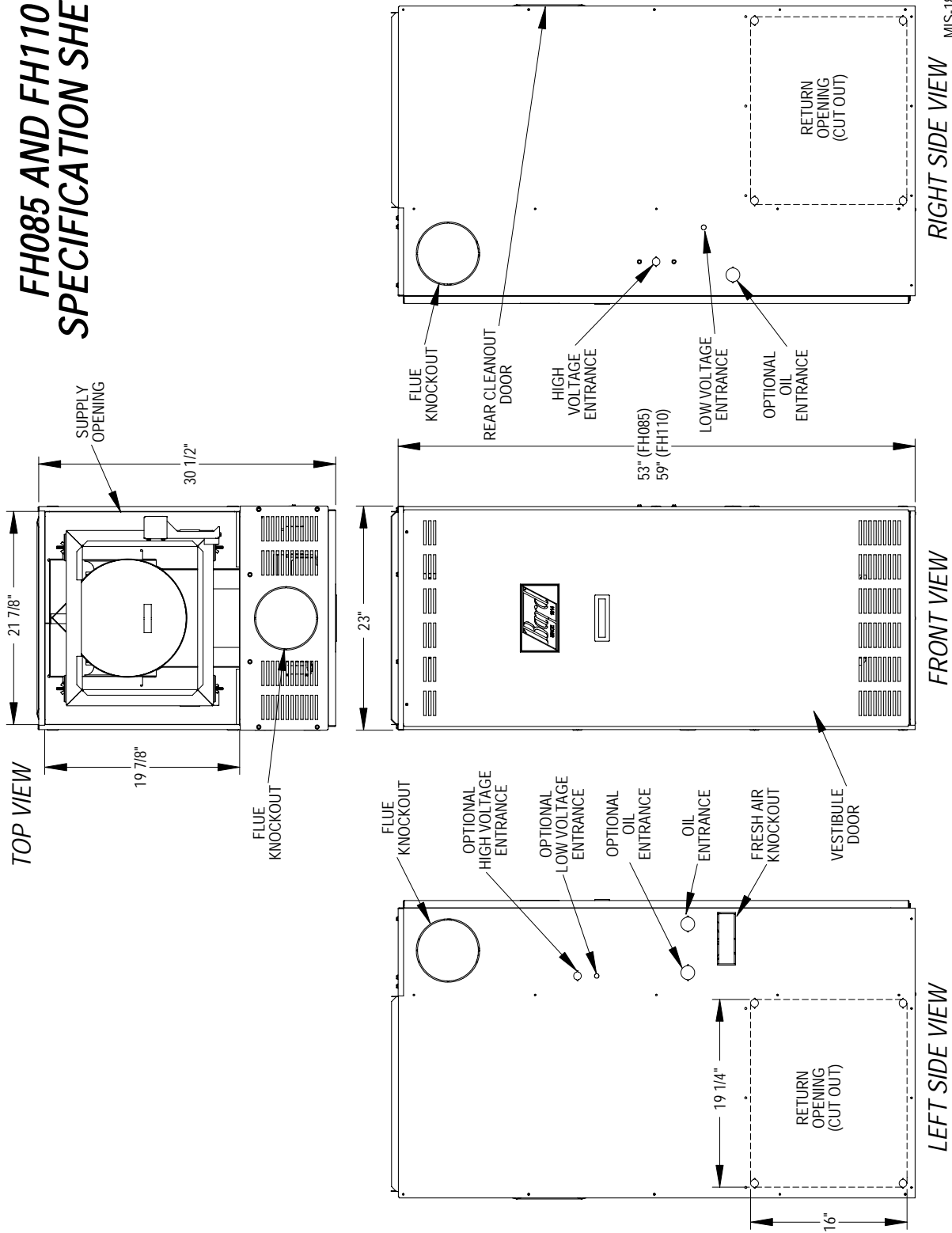
① Washable type filter 1" nom. thickness

FLF/FLR 085, 110 AND 140
SPECIFICATION SHEET



FH085 AND FH110 SPECIFICATION SHEET

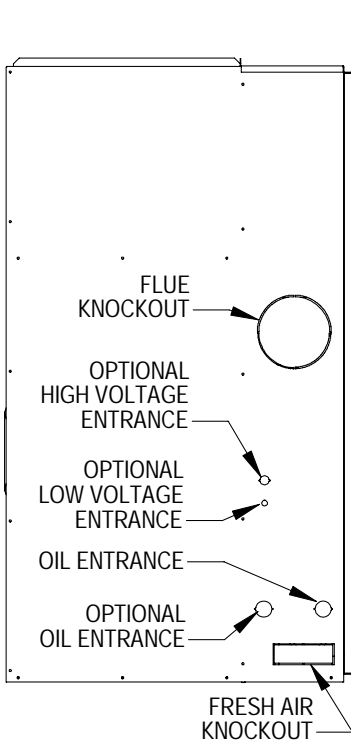
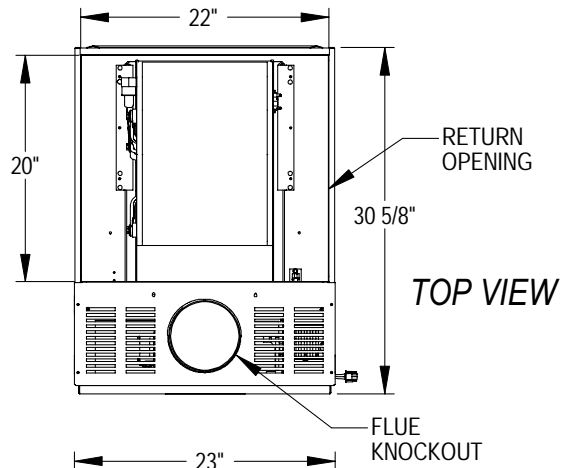
**FIGURE 2
FH MODELS DIMENSIONS**



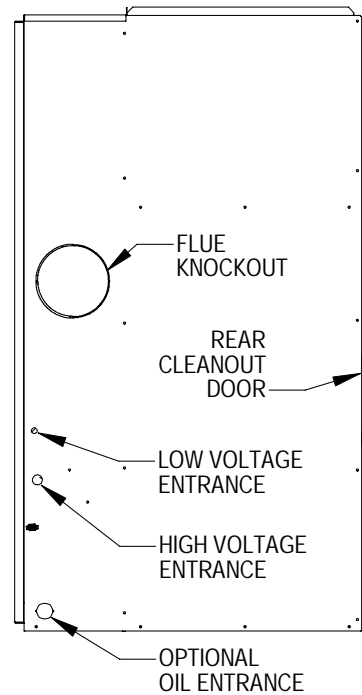
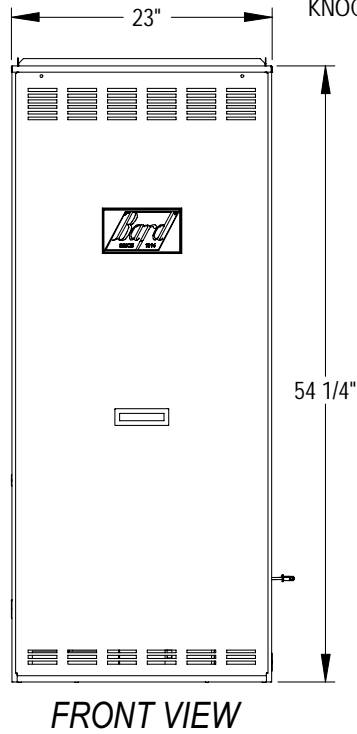
MIS-1814 A

**FIGURE 3
FC085 MODEL DIMENSIONS**

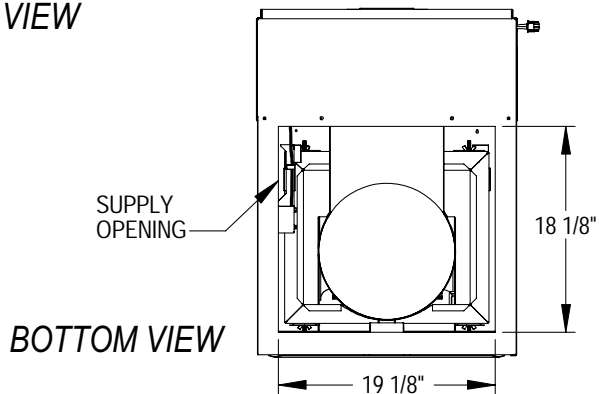
**COUNTERFLOW
SPECIFICATION
SHEET**



LEFT SIDE VIEW



RIGHT SIDE VIEW



MIS-1826 A

INSTALLING THE FURNACE

INSTRUMENTS REQUIRED FOR PROPER SETUP OF THE FURNACE

It is important that a set of instruments capable of the following requirements be used for the setup of this furnace to ensure proper and safe operation:

1. Oil pump pressure gauge that measures up to 150 PSI.
2. Smoke gun to pull smoke samples from flue.
3. Draft gauge that will measure -.02" water column (W.C.)
4. Duct static pressure gauge 0-1.0" W.C. range.
5. Temperature gauge that can read from 50° F up to 700° F.
6. A gauge to measure CO₂ or O₂.

INSTALLATION

A typical installation is shown in Figures 4 and 5. All parts of the furnace installation (furnace, oil tank and piping systems, combustion and ventilation air, venting, etc.) must comply with NFPA31, Installation of Oil Burning Equipment -- latest edition. This drawing shows the typical connecting parts needed to correctly install this furnace. Make sure that all parts of the heating system comply with the local codes.

Check the furnace and your load calculation to verify that the unit is properly sized. (Refer to "Equipment Selection" section on Page 4.)

The correct size of unit needed may be substantially smaller than the unit being replaced due to home improvements and technology advancements since the initial installation.

INADEQUATE SUPPLY AIR and/or RETURN AIR DUCT SYSTEMS

Short cycling because of limit control operation can be created by incorrectly designed or installed supply and/or return air duct systems.

The duct systems must be designed using ASHRAE or ACCA design manuals and the equipment CFM and external static pressure ratings to ensure proper air delivery capabilities.

On replacement installations, particularly if equipment is oversized, the duct systems can easily be undersized. Modifications may be required to assure that the equipment is ***operating within the approved temperature rise range when under full rated input conditions***, and that no short cycling on limit controls is occurring.

DUCT WORK

The air distribution system should be designed and installed in conformance with manuals published by Air Conditioning Contractors of America (ACCA) as set forth in Manual D, or ASHRAE publications.

IMPORTANT

When a furnace is installed so that supply ducts carry air circulated by the furnace to areas outside the space containing the furnace, the return air must also be handled by a duct(s) sealed to the furnace casing and terminating outside the space containing the furnace. This is to prevent drawing possible hazardous combustion products into the circulated air.

INSTALLING A COOLING UNIT

When the furnace is used in connection with a cooling unit*, the furnace shall be installed parallel with or on the upstream side of the cooling unit to avoid condensation in the heating element. With a parallel flow arrangement, the dampers or other means used to control flow of air shall be adequate to prevent chilled air from entering the furnace, and if manually operated, must be equipped with means to prevent operation of either unit, unless the damper is in the full heat or cool position.

* *A cooling unit is an air conditioning coil, heat pump coil or chilled water coil.*

When installing a cooling unit above an FH or FL (below on an FC) series furnace, the coil must be spaced far enough from the furnace outlet to assure proper operation of the furnace. Bard supplied coils, when used with Bard supplied coil cabinets, are automatically positioned.

For top discharge FH and FL models, when coils are installed without using Bard coil cabinets or coils of another brand are used, the coil drain pan should be located a minimum of four (4) inches above the top of the furnace cabinet. If a greater clearance is specified by the coil manufacturer then it would apply.

NOTE: IF DRAIN PAN IS ANYTHING OTHER THAN A STEEL PAN PARTICULAR ATTENTION MUST BE GIVEN TO THE INSTALLATION INSTRUCTIONS FOR THE COIL TO MAKE SURE IT IS ACCEPTABLE FOR USE WITH THESE OIL FURNACES HAVING MAXIMUM OUTLET AIR TEMPERATURE OF 200° F.

See Cooling Tap Select Table D (Page 19) for CFM at static pressures for additional information.

WIRING

FACTORY WIRING

All units are fully factory wired. Multispeed blowers are factory wired on high speed for cooling/manual fan operation. Heating speeds are wired for the largest input and may need lower speed for field installed low input nozzle. If replacement wire is necessary, use 105 degrees C minimum. See electrical data, Table 3.

FIELD WIRING

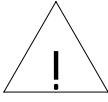
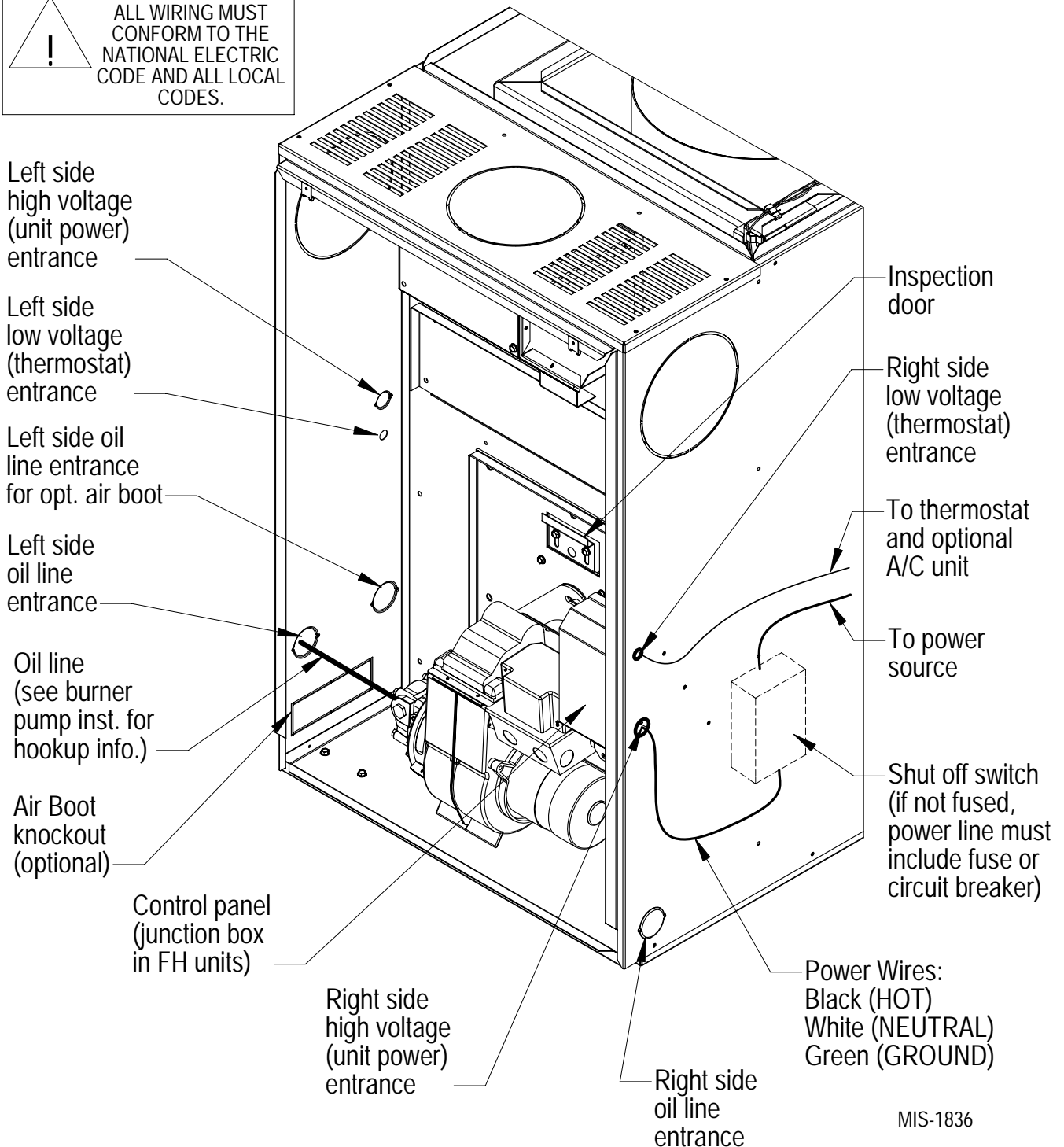
All wiring must conform to the National Electrical Code and all local codes. A separate fuse or breaker should be used for the furnace.

**TABLE 3
ELECTRICAL DATA**

Model	Volts-HZ-PH	Total Amps	Blower Motor		Burner Motor		Minimum Circuit Ampacity	Max. Time Delay Fuse or HACR Circuit Breaker
			HP	FLA	HP	FLA		
FC085V42A	115-60-1	8.6	1/2	6.9	1/7	1.7	10.3	15
FH085V42A	115-60-1	8.6	1/2	6.9	1/7	1.7	10.3	15
FH110V48A	115-60-1	10.3	3/4	8.6	1/7	1.7	12.5	15
FH110V60A	115-60-1	15.2	1	13.5	1/7	1.7	18.6	20
FLF085V42A	115-60-1	8.6	1/2	6.9	1/7	1.7	10.3	15
FLF110V48A	115-60-1	10.3	3/4	8.6	1/7	1.7	12.5	15
FLF110V60A	115-60-1	15.2	1	13.5	1/7	1.7	18.6	20
FLR085V42A	115-60-1	8.6	1/2	6.9	1/7	1.7	10.3	15
FLR110V48A	115-60-1	10.3	3/4	8.6	1/7	1.7	12.5	15
FLR110V60A	115-60-1	15.2	1	13.5	1/7	1.7	18.6	20
FLR140V60A	115-60-1	14.5	1	12.8	1/7	1.7	17.7	20

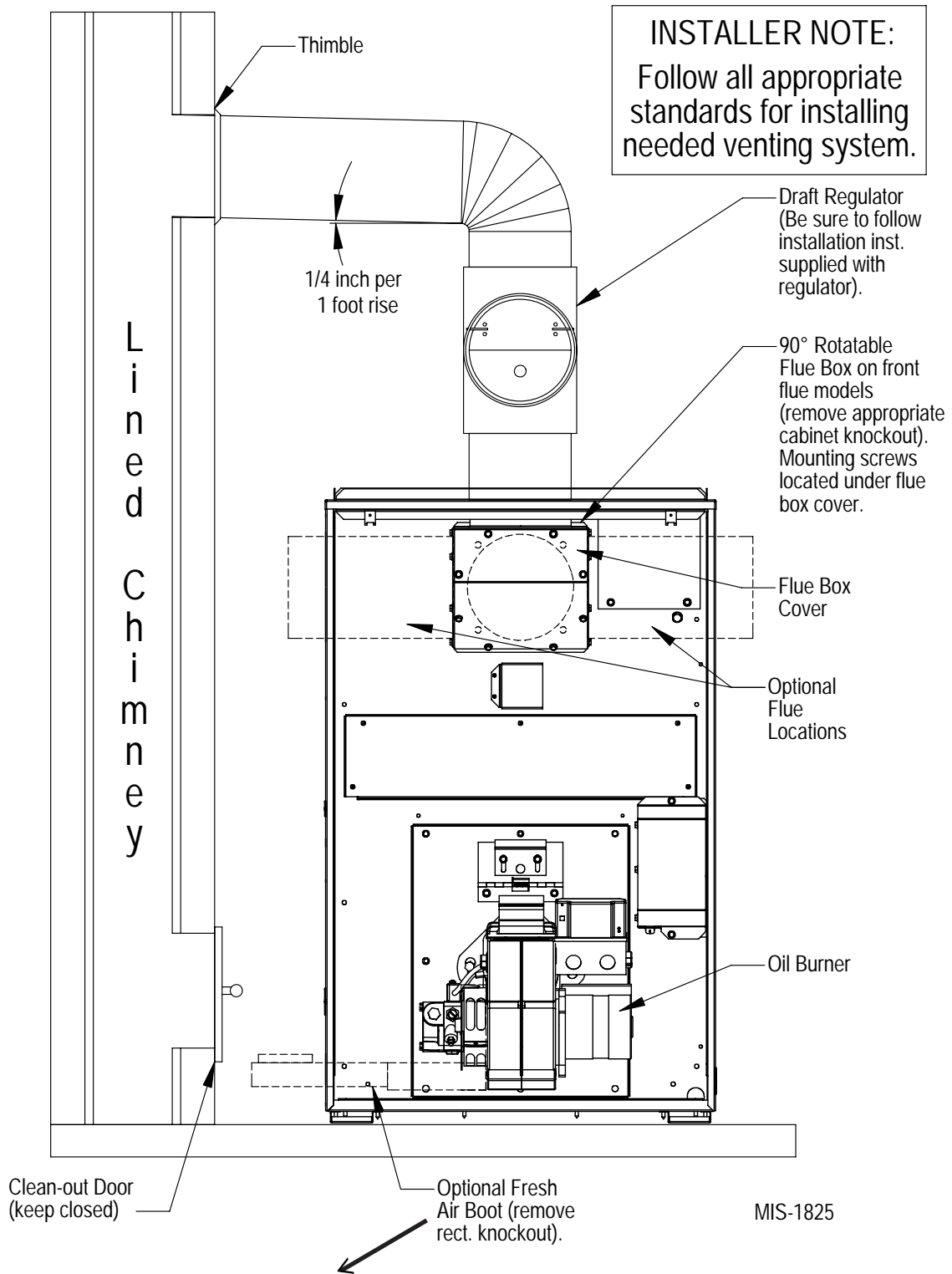
**FIGURE 4
TYPICAL UNIT SETUP
FLF UNIT SHOWN**

WARNING
ALL WIRING MUST
CONFORM TO THE
NATIONAL ELECTRIC
CODE AND ALL LOCAL
CODES.

MIS-1836

FIGURE 5
TYPICAL FLUE INSTALLATION REQUIREMENTS
FRONT FLUE LO-BOY MODEL SHOWN
(REPRESENTS ALL MODELS)



**Note: This accessory is not currently available for Bard Models:
 FH110V48A, FH110V60A, FLF110V48A, FLF110V60A with NX Burners**

OIL LINE PIPING

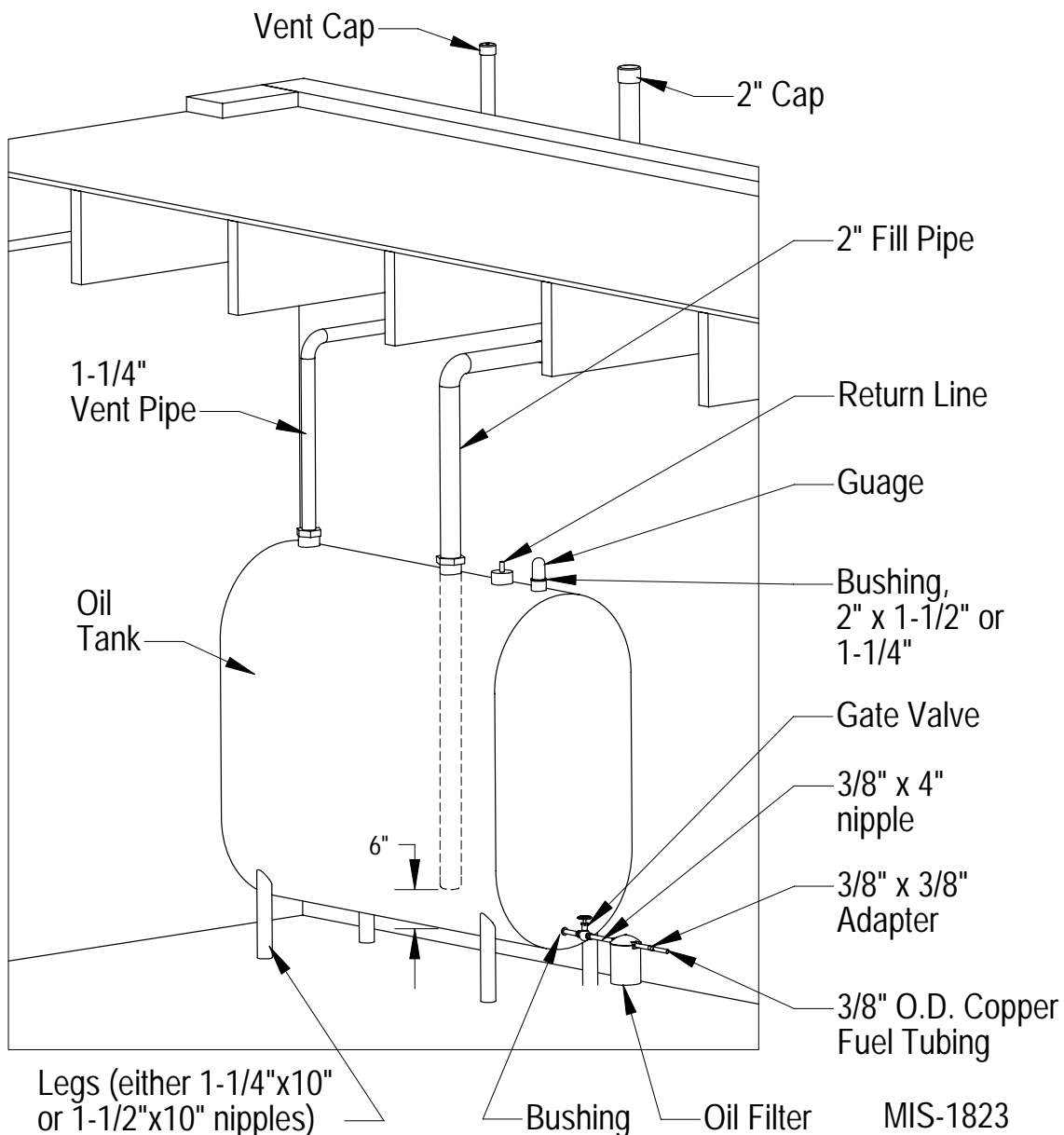
First determine whether the pipe system is to be a single line system or a two line system. All connections must be absolutely air tight or you will have a malfunction of the burner. When installing the piping, a good oil filter should be installed close to the burner. A single line system is recommended for gravity feed.

A typical single inside tank installations shown in Figure 6. For installation details for this and other tank configurations, refer to NFPA31 -- latest edition. All tank and pipe setups must comply with NFPA31.

BECKETT AFG OR NX OIL BURNER

This furnace is equipped with a high static Beckett AFG or Beckett NX oil burner which is designed to produce adequate draft in nearly any vertically vented application. The burner employs the latest time tested controls of the highest quality. The controls consist of a high voltage Beckett solid state igniter, a Beckett "CleanCut" oil pump with an integral solenoid valve, and a Genisys 7505 primary control.

**FIGURE 6
TYPICAL SINGLE INSIDE TANK INSTALLATION**



These controls were selected for their proven high quality, dependability, and serviceability. With proper maintenance this burner assembly will provide many years of reliable service.

All units are shipped with the oil burner installed, and with high rate oil nozzle installed designed for use with No. 1 or No. 2 fuel oil. **Inspect firepot refractory before firing to be sure it has not been jarred out of position in shipment. Burner air tube *must not* extend beyond inside surface of firepot. Burner head should be centered on the combustion chamber opening.**

WARNING

Never attempt to use gasoline in your furnace. Gasoline is more combustible than fuel oil and could result in a serious explosion causing damage, injury or death.

The following is a detailed explanation of each control included in the Beckett AFG Oil Burner, how each operates, how to set up the burner, and how to troubleshoot problems should they occur.

BECKETT “CLEANCUT” OIL PUMP

This oil pump is equipped with an oil solenoid valve installed in the pump housing. This feature provides quick cutoffs resulting in reduction in smoke after the burner shuts down. This is a time proven pump design and is capable of both one and two pipe systems. All installation and set up instructions are outlined in the “Oil Pump Specification” section of the installation instructions manual.

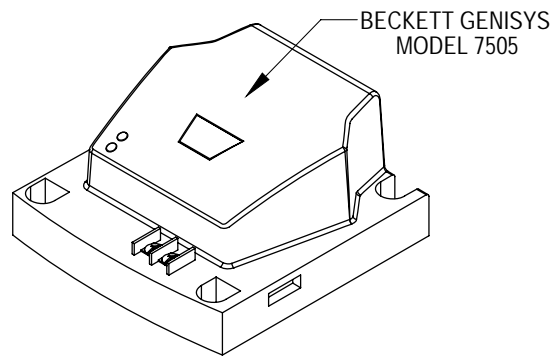
BECKETT SOLID STATE IGNITER

This igniter differs from the traditional iron core transformer in that it produces a 14,000 volt spark instead of a 10,000 volt spark of the iron core transformer. This hotter spark provides for cleaner, faster ignitions. Being solid state technology this igniter is less susceptible to problems caused by voltage variations. It also has a greater ability to ignite cold and/or inconsistent oil. The solid state igniter is wired to the primary control the same as an iron core transformer.

GENISYS 7505 PRIMARY CONTROL

The Genisys 7505 Interrupted Electronic Oil Primary is a line voltage, safety rated, interrupted ignition oil primary control for residential oil burners. The Genisys 7505 used with a cad cell flame sensor, operates the oil burner and oil valve. The primary controls fuel oil, senses flame, controls ignition spark and is designed to notify a remote alarm circuit before going into lockout when equipped with a flame monitoring system.

This primary control possesses the latest technology, is a very simple control to operate and provides additional troubleshooting features to ease service and reduce down time. The operational guide for the Genisys 7505 primary control is provided following on Page 14.

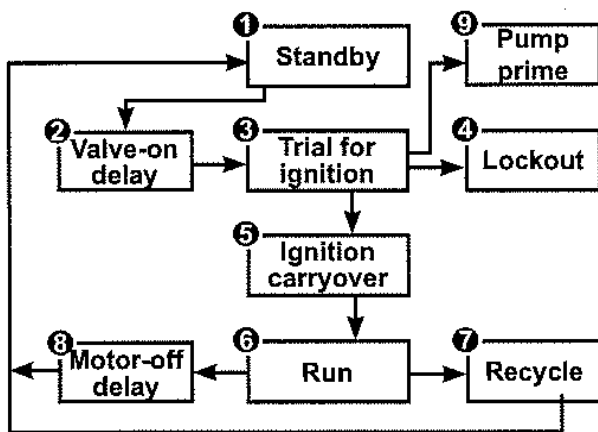


MIS-2491

PRIMARY OPERATIONAL GUIDE

BECKETT GENISYS 7505

Sequence of Operation



BURNER STATES

1. **Standby:** The burner is idle, waiting for a call for heat.
2. **Valve-On Delay (Prepurge):** The igniter and motor are on while the control delays turning on the oil solenoid valve for the programmed time.
3. **Trial for Ignition:** The fuel valve is opened. A flame should be established within the factory set trial for ignition time ("lockout time").
4. **Lockout:** The control has shut the burner down for one of the following safety reasons:
 - The trial for ignition (lockout) time expires without flame being established.
 - The cad cell detects flame during Valve-On Delay.
 - The Recycle mode 30-second time budget expires (see "Recycle" section for complete explanation of recycle time budget).

If the control locks out three times without completing a successful call for heat, the control enters Restricted (Hard) Lockout, and must be reset by a technician. Hold the reset button for 15 seconds until the red light shuts off to reset from Restricted Lockout.

5. **Ignition Carryover:** Once flame is established, the igniter remains on for 10 additional seconds to ensure flame stability.

6. **Run:** The flame is sustained until the call for heat is satisfied. The burner is then sent to Motor-Off Delay (Postpurge), if applicable, or it is shut down and sent to Standby.

7. **Recycle:** If the flame is lost while the burner is firing, the control shuts down the burner, enters a 60-second recycle delay and then repeats the ignition sequence. The control will continue to Recycle each time the flame is lost until the accumulated oil-flow-without-flame time reaches 30 seconds, at which point the control will go into lockout. This feature prevents excessive accumulation of oil in the appliance firing chamber.

8. **Motor-Off Delay:** If applicable, the fuel valve is closed and the control delays turning the motor off for the set motor-off delay time before the control returns to standby.

9. **Pump Prime:** The igniter and motor are on with the oil valve open for up to 4 minutes. During Pump Prime mode, the cad cell is disregarded, allowing the technician to prime the pump without having to jumper the cad cell.

RESET BUTTON OPERATION

- **Table A** explains what action the control will take when the reset button is pressed for different lengths of time during the various burner operating states.

**TABLE A
RESET BUTTON OPERATION**

If the burner is in the below state:	Pushing the Reset button will:		
	Button Click (press < 1 second)	Button Hold (press > 1 second)	Button Hold (press 15+ seconds)
Lockout	Reset from Soft Lockout		Reset from Restricted (Hard) Lockout
Valve-on Delay, Trial for Ignition, Ignition Carryover	Go to Pump Prime (see Below)	Disable the Burner: Any time the burner is running, press and hold the reset button to disable the burner. The burner will remain off as long as the button is held.	Enables Pump Priming: After the reset button has been held for 15 seconds, the button can then be tapped during the next ignition sequence to enter Pump Prime mode.
Run (igniter is shut off)	Yellow LED flashes to indicate cad cell resistance. See "Cad Cell Resistance Indicator" for table of resistance values.		
Motor-Off Delay, Standby	No action		
Pump Prime	No action	Exit Pump Prime mode and return to Standby	

**TABLE B
STATUS LIGHTS**

LED Color	On Continuously	Flashing
Red	Restricted (hard) Lockout	Soft Lockout
Green	Flame Detected (Could be flame or stray light)	Recycle
Yellow	Control is in Pump Prime mode <i>or</i> Reset button currently held for 15+ seconds	Cad Cell resistance. See "Cad Cell Resistance Indicator" section for table of resistance values.

PRIMING THE PUMP



WARNING

Hot Gas Puff-Back & Heavy Smoke Hazard

Failure to bleed the pump properly could result in unstable combustion, hot gas puff-back and heavy smoke.

- Do not allow oil to spray into a hot combustion chamber while bleeding air from the pump.
- Install a gauge in the nozzle discharge port tubing or fully open the pump bleed valve to prevent oil spray from accumulating in the combustion chamber during the air bleed procedure.
- Ensure that all bubbles and froth are purged from the oil supply system before tightening the pump air bleed valve.

1. Prepare the burner for priming by fully opening the pump bleed port and attaching a clear plastic hose over the bleed port fitting. Use a suitable container to collect purged oil.
2. Initiate a call for heat.
3. After the burner starts, press and hold the reset button for 15 seconds until the yellow LED turns on. This indicates that the button has been held long enough.
4. Release the reset button. The yellow LED will turn off and the burner will start up again.

5. At burner start up, tap the reset button within the first 10 seconds of the ignition cycle. This will transition the control to a dedicated Pump Prime mode, during which the motor, igniter and valve are powered for four minutes. The yellow LED will be on.
6. Bleed the pump until all froth and bubbles are purged. If desired, hold the reset button for at least one second to exit Pump Prime mode and return to Standby.
7. At the end of 4 minutes, the yellow LED will turn off and the control will automatically return to standby mode.
8. If prime is not established during the four minute pump prime mode, return to step 5 to re-enter Pump Prime mode. Repeat steps 5 through 7 until the pump is fully primed and the oil is free of bubbles.
9. Terminate the call for heat, and the control will resume normal operation.

CAD CELL RESISTANCE INDICATOR

- During the burner Run state, tap the reset button (less than 1 second) to check the cad cell resistance range. The yellow LED will flash 1 to 4 times depending on the amount of light detected by the cad cell. See chart below:

Yellow LED Flashes	Flame Detection Range
1	Normal (0 - 400 ohms)
2	Normal (400 - 800 ohms)
3	Normal (800 - 1600 ohms)
4	Limited (1600 ohms - Lockout)

RESETTING FROM RESTRICTED LOCKOUT

- If the control locks out three times without a satisfied call for heat, or due to other significant events such as a relay contact weld, the Lockout becomes *restricted* in order to prevent repetitious resetting by the homeowner.



CAUTION

Before resetting the control from restricted lockout state, troubleshoot the heating system for the root cause(s) of lockout and make necessary repairs or adjustment to ensure a safe start condition.

- Then, to reset, hold the button down for 15 seconds until the red light turns off and the yellow LED turns on. Observe at least one full control sequence of operation from startup to shutdown. Simulate a flame failure lockout by following the procedure (within this manual). If the operation is erratic, or not to specifications, then replace the control. Always verify the control functions according to all specifications before leaving the installation site.

DISABLE FUNCTION

- Any time the burner is running, press and hold the reset button to disable the burner. The burner will remain off as long as the button is held.

Burner Option – Flame Quality Monitor

This control is trained to recognize and remember a good flame based on initial burner set up. Control then monitors the flame via the CAD cell signal for deviation in the combustion characteristics of the burner. If the control senses a deviation on the high side or on the low side from the original set up condition for three consecutive cycles, it will trigger an alarm circuit which can be tied to an audible local device to signal the home owner or into the home security system. Upon being notified of the alarm, the security agency will notify the dealer of choice based upon information supplied by the home owner. The system will also be capable of being connected to a phone line that will contact the dealer directly with the alarm. This alarm will typically sound 3 to 5 days prior to the primary control going into lockout giving the service agency a prior notice before a sooting condition or other failure can occur resulting in untold savings. This monitor system is available through your local distributor under the Honeywell Part #QS7100F.

Electronic Blower Control Interface

This furnace is equipped with an Electronic Blower Control Interface, which through its set points determines what the blower does with the 24 VAC inputs from the home thermostat.

There are dip switches that control the ECM motor for:

1. Heating Airflow
2. Cooling Airflow
3. Heating On/Off Delay
4. A $\pm 10\%$ adjustment for heating airflows.

(See to Figure 7 for the location of these switches.)

The Electronic Blower Control Interface also performs the additional functions of having a diagnostic light, which indicates a safety limit is open, and also has a relay which isolates the T-T signal from the oil primary control.

Required 24 VAC inputs for various functions:

Continuous Blower: “R” to “G”

Heating with Oil Furnace: “R” to “W”

Cooling Single Stage: “R” to “G”, “Y1” & “Y2”

Cooling Two-Stage, Part Load: “R” to “G” & “Y1”

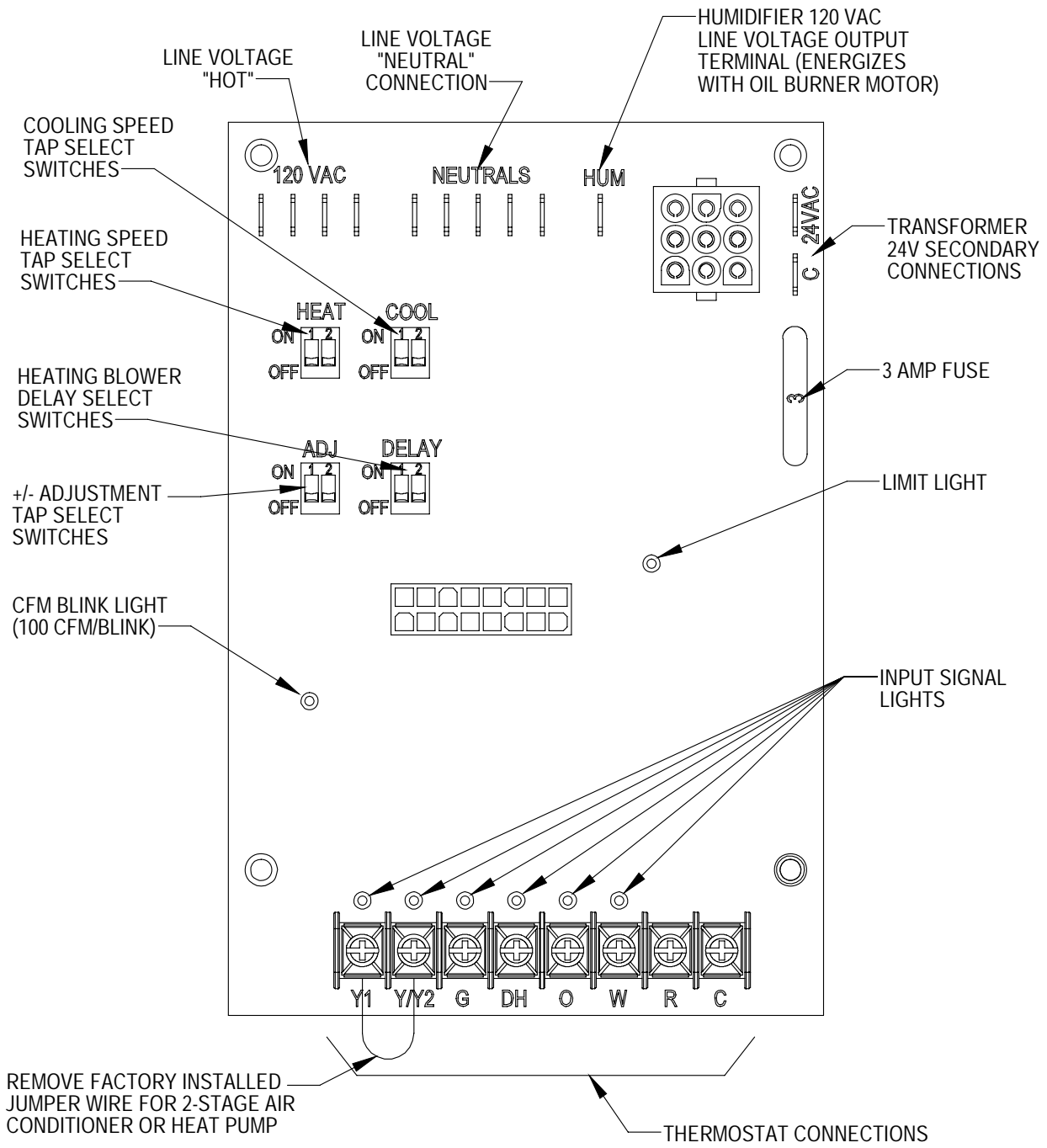
Cooling Two-Stage, Full Load: “R” to “G”, “Y1” & “Y2”

Heat Pump Single Stage: “R” to “G”, “Y1”, “Y2” & “O”

Heat Pump Two-Stage, Part Load: “R” to “G”, “Y1” & “O”

Heat Pump Two-Stage, Full Load: “R” to “G”, “Y1”, “Y2” & “O”

**FIGURE 7
ELECTRONIC BLOWER CONTROL**



MIS-2869

**TABLE C
HEATING TAP SELECT SETTINGS BY MODEL**

Model	GPH Input	Tap Letter	Switch #1	Switch #2	Heating CFM (0" - 0.5" E.S.P.)
FC085V42A	0.75	A	OFF	OFF	1075
FH085V42A		B	ON	OFF	1035
FLF085V42A	0.65	C	OFF	ON	930
FLR085V42A	0.55	D	ON	ON	790
FH110V48A	1.00	A	OFF	OFF	1280
FLF110V48A		B	ON	OFF	1225
FLR110V48A	0.85	C	OFF	ON	1060
FLR110V48A		D	ON	ON	1060
FH110V60A	1.00	A	OFF	OFF	1280
FLF110V60A		B	ON	OFF	1225
FLR110V60A	0.85	C	OFF	ON	1060
FLR110V60A		D	ON	ON	1060
FLR140V60A	1.25	A	OFF	OFF	1860
		B	ON	OFF	1790
	1.10	C	OFF	ON	1645
		D	ON	ON	1645

**TABLE D
COOLING TAP SELECT SETTINGS BY MODEL**

Model	GPH Input	Tap Letter	Switch #1	Switch #2	Nominal Cooling Tonnage	COLUMN A	COLUMN B
						Cooling Full Load CFM (0" - 0.5" E.S.P.)	Cooling Part Load CFM (0" - 0.5" E.S.P.)
FC085V42A	0.75	A	OFF	OFF	3.5	1400	1000
FH085V42A		B	ON	OFF	3	1200	850
FLF085V42A	0.65	C	OFF	ON	2.5	1000	725
FLR085V42A	0.55	D	ON	ON	2	800	575
FH110V48A	1.00	A	OFF	OFF	4	1600	1150
FLF110V48A		B	ON	OFF	3.5	1400	1000
FLR110V48A	0.85	C	OFF	ON	3	1200	850
FLR110V48A		D	ON	ON	2.5	1000	725
FH110V60A	1.00	A	OFF	OFF	5	2000	1450
FLF110V60A		B	ON	OFF	4	1600	1150
FLR110V60A	0.85	C	OFF	ON	3.5	1400	1000
FLR110V60A		D	ON	ON	3	1200	850
FLR140V60A	1.25	A	OFF	OFF	5	2000	1450
		B	ON	OFF	4	1600	1150
	1.10	C	OFF	ON	3.5	1400	1000
		D	ON	ON	3	1200	850

Note: Part Load Airflow for 2-stage A/C or HP systems is achieved when removing the factory installed jumper wire on the Electronic Blower Control Interface Board that is (installed) between the thermostat connection screws "Y2" and "Y1" dependent upon the tap selected. This allows for 2-stage A/C or HP systems to be installed with this product. (See Figure 7 or the Wiring Diagrams.)

For 1-stage compressor systems requiring lower airflow than shown in Column A, remove "Y1-Y2" jumper to achieve Column B airflow delivery.

**TABLE E
ADJUSTMENT TAP SELECTS**

Model	Tap Letter	Switch #1	Switch #2	Function
ALL	A	OFF	OFF	No Change
	B	ON	OFF	+ 10% Heating Airflow
	C	OFF	ON	-10% Heating Airflow
	D	ON	ON	No Change

**TABLE F
HEATING DELAY PROFILE TAPS**

Model	Tap Letter	Switch #1	Switch #2	On Delay Seconds	On Delay % CFM	Pre-Run Time Seconds	Pre-Run % CFM	Off Delay Seconds	Off Delay % CFM
ALL	A	OFF	OFF	30	0	60	50	300	82
	B	ON	OFF	30	0	60	50	240	100
	C	OFF	ON	45	0	120	50	300	88
	D	ON	ON	60	0	0	100	180	100

TROUBLESHOOTING GE ECM 2.3™ MOTORS

16-PIN BLOWER TAP SELECT CONTROLS - OUTPUTS BASED UPON MODE

Mode of Operation	OFF	Continuous Blower	Oil Furnace	Single Stage Cooling	2-Stage Cooling, Part Load	2-Stage Cooling, Full Load	Heat Pump Single Stage Cooling	2-Stage Heat Pump Cooling, Part Load	2-Stage Heat Pump Cooling, Full Load	Heat Pump Single Stage Heating	2-Stage Heat Pump Heating, Part Load	2-Stage Heat Pump Heating, Full Load
Thermostat 24 VAC Input Signals	—	"G"	"W"	"G", "Y1"	"G", "Y1"	"G", "Y1", "Y2"	"G", "Y1", "O"	"G", "Y1", "O"	"G", "Y1", "Y2", "O"	"G", "Y1", "O"	"G", "Y1", "O"	"G", "Y1", "Y2", "O"
Pin #1	24 VAC "C" (Common) Signal; Always Energized.											
Pin #2		X										
Pin #3	24 VAC "C" (Common) Signal; Always Energized.											
Pin #4	Delay Tap Profiles; Varied Half-Wave Signals Based Upon Settings.											
Pin #5	Cool Tap Select Tables; Varied Half-Wave Signals Based Upon Settings (Tonnage).											
Pin #6			X	X	X		X	X		X	X	X
Pin #7	Adjustment Tap Profiles; Varied Half-Wave Signals Based Upon Settings.											
Pin #8	DC Volts "-": Output in Direct Correlation to CFM.											
Pin #9							X		X	X		X
Pin #10	Future Use; Not Currently Programmed for Function.											
Pin #11	Heat Tap Select Tables; Varied Half-Wave Signals Based Upon Tonnage.											
Pin #12	24 VAC Hot "R" Signal; Always Energized.											
Pin #13	Energized When Limit Trip Occurs.											
Pin #14				X	X	X	X		X	X		X
Pin #15		X		X	X	X	X	X	X	X	X	X
Pin #16	DC Volts "-": Output in Direct Correlation to CFM.											

① Requires "Y1" to "Y2" jumper wire installed on Integrated Blower Interface.
 ② Requires removal of Factory Installed "Y1" to "Y2" jumper wire on Electronic Blower Control Interface.

TROUBLESHOOTING GE ECM 2.3™ MOTORS

CAUTION:

Disconnect power from unit before removing or replacing connectors, or servicing motor. To avoid electric shock from the motor's capacitors, disconnect power and wait at least 5 minutes before opening motor.

Symptom

Cause/Procedure

Motor rocks slightly when starting

- This is normal start-up for ECM

Motor won't start

- No movement

- Check blower turns by hand
- Check power at motor
- Check low voltage (24 Vac R to C) at motor
- Check low voltage connections (G, Y, W, R, C) at motor
- Check for unseated pins in connectors on motor harness
- Test with a temporary jumper between R - G
- Check motor for tight shaft
- Perform motor/control replacement check
- **Perform Moisture Check**

- Motor rocks, but won't start

- Check for loose or compliant motor mount
- Make sure blower wheel is tight on shaft
- Perform motor/control replacement check

Motor oscillates up load & down while being tested off of blower

- It is normal for motor to oscillate with no on shaft

Motor starts, but runs erratically

- Varies up and down or intermittent

- Check line voltage for variation or "sag"
- Check low voltage connections (G, Y, W, R, C) at motor, unseated pins in motor harness connectors
- Check "Bk" for erratic CFM command (in variable-speed applications)
- Check out system controls, Thermostat
- **Perform Moisture Check**

- "Hunts" or "puffs" at high CFM (speed)

- Does removing panel or filter reduce "puffing"?
 - Reduce restriction
 - Reduce max airflow

- Stays at low CFM despite system call for cool or heat CFM

- Check low voltage (Thermostat) wires and connections
- Verify fan is not in delay mode; wait until delay complete
- "R" missing/not connected at motor
- Perform motor/control replacement check

- Stays at high CFM

- "R" missing/not connected at motor
- Is fan in delay mode? - wait until delay time complete
- Perform motor/control replacement check

- Blower won't shut off

- Current leakage from controls into G, Y or W? Check for Triac switched thermostat or solid-state relay

Excessive noise

- Air noise

- Determine if it's air noise, cabinet, duct or motor noise; interview customer, if necessary
- High static creating high blower speed?
 - Is airflow set properly?
 - Does removing filter cause blower to slow down? Check filter
 - Use low-pressure drop filter
 - Check/correct duct restrictions

Symptom

- Noisy blower or cabinet

Cause/Procedure

- Check for loose blower housing, panels, etc.
- High static creating high blower speed?
 - Check for air whistling through seams in ducts, cabinets or panels
 - Check for cabinet/duct deformation

- "Hunts" or "puffs" at high CFM (speed)

- Does removing panel or filter reduce "puffing"?
 - Reduce restriction
 - Reduce max. airflow

Evidence of Moisture

- Motor failure or malfunction has occurred and moisture is present
- Evidence of moisture present inside air mover

- Replace motor and **Perform Moisture Check**

- **Perform Moisture Check**

Do

- Check out motor, controls, wiring and connections thoroughly before replacing motor
- Orient connectors down so water can't get in
 - Install "drip loops"
- Use authorized motor and model #'s for replacement
- Keep static pressure to a minimum:
 - Recommend high efficiency, low static filters
 - Recommend keeping filters clean.
 - Design ductwork for min. static, max. comfort
 - Look for and recommend ductwork improvement, where necessary

Don't

- Automatically assume the motor is bad.
- Locate connectors above 7 and 4 o'clock positions
- Replace one motor or control model # with another (unless an authorized replacement)
- Use high pressure drop filters some have 1/2" H2O drop!
- Use restricted returns
- Oversize system, then compensate with low airflow
- Plug in power connector backwards
- Force plugs

Moisture Check

- Connectors are oriented "down" (or as recommended by equipment manufacturer)
- Arrange harness with "drip loop" under motor
- Is condensate drain plugged?
- Check for low airflow (too much latent capacity)
- Check for undercharged condition
- Check and plug leaks in return ducts, cabinet

Comfort Check

- Check proper airflow settings
- Low static pressure for lowest noise
- Set low continuous-fan CFM
- Use humidistat and 2-speed cooling units
- Use zoning controls designed for ECM that regulate CFM
- Thermostat in bad location?

TROUBLESHOOTING GE ECM™ MOTORS CONT'D.

Replacing ECM Control Module

To replace the control module for the GE variable-speed indoor blower motor you need to take the following steps:

1. You **MUST** have the correct replacement module. The controls are factory programmed for specific operating modes. Even though they look alike, different modules may have completely different functionality.

USING THE WRONG CONTROL MODULE VOIDS ALL PRODUCT WARRANTIES AND MAY PRODUCE UNEXPECTED RESULTS.

2. Begin by removing AC power from the unit being serviced. **DO NOT WORK ON THE MOTOR WITH AC POWER APPLIED.** To avoid electric shock from the motor's capacitors, disconnect power and wait at least 5 minutes before opening motor.

3. It is not necessary to remove the motor from the blower assembly, nor the blower assembly from the unit. Unplug the two cable connectors to the motor control assembly. There are latches on each connector. **DO NOT PULL ON THE WIRES.** The plugs remove easily when properly released.

4. Locate the screws that retain to the motor control bracket to the sheet metal of the unit and remove them. Remove two (2) nuts that retain the control to the bracket and then remove two (2) nuts that retain sheet metal motor control end plate. Refer to Figure 8.

5. Disconnect the three (3) wires interior of the motor control by using your thumb and forefinger squeezing the latch tab and the opposite side of the connector plug, gently pulling the connector. **DO NOT PULL ON THE WIRES, GRIP THE PLUG ONLY.** Refer to Figure 8.

6. The control module is now completely detached from the motor. Verify with a standard ohmmeter that the resistance from each motor lead (in the motor plug just removed) to the motor shell is >100K ohms. Refer to Figure 9. (Measure to unpainted motor end plate.) If any motor lead fails this test, do not proceed to install the control module. **THE MOTOR IS DEFECTIVE AND MUST BE REPLACED.** Installing the new control module will cause it to fail also.

7. Verify that the replacement control is correct for your application. Refer to the manufacturer's authorized replacement list. **USING THE WRONG CONTROL WILL RESULT IN IMPROPER OR NO BLOWER OPERATION.** Orient the control module so that the 3-wire motor plug can be inserted into the socket in the control. Carefully insert the plug and press it into the socket until it latches. **A SLIGHT CLICK WILL BE HEARD WHEN PROPERLY INSERTED.**

8. Reverse the steps #5, 4, 3 to reconnect the motor control to the motor wires, securing the motor control cover plate, mounting the control to the bracket, and mounting the motor control bracket back into the unit. **MAKE SURE THE ORIENTATION YOU SELECT FOR REPLACING THE CONTROL ASSURES THE CONTROL'S CABLE CONNECTORS WILL BE LOCATED DOWNWARD IN THE APPLICATION SO THAT WATER CANNOT RUN DOWN THE CABLES AND INTO THE CONTROL. DO NOT OVERTIGHTEN THE BOLTS.**

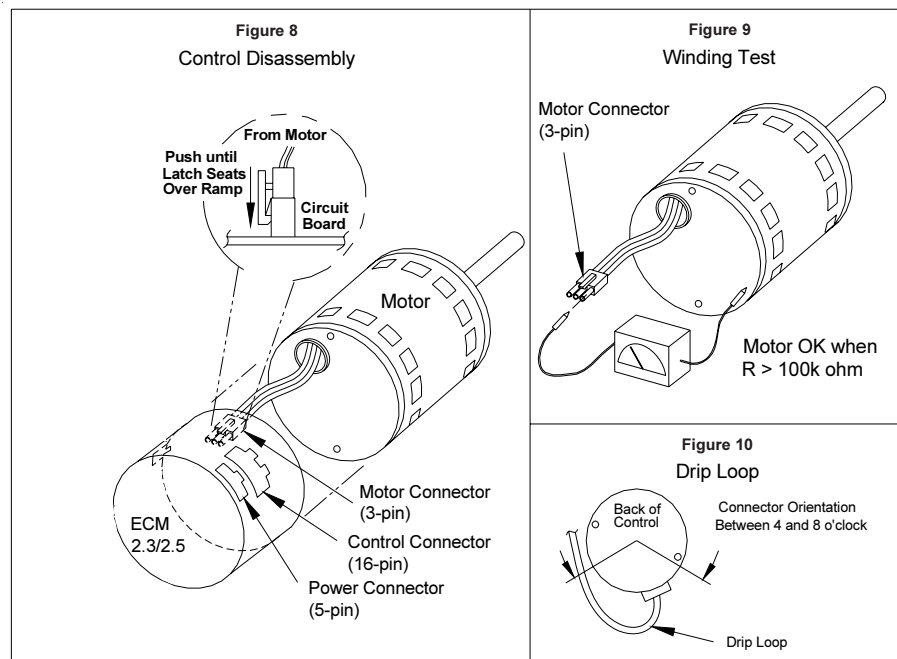
9. Plug the 16-pin control plug into the motor. The plug is keyed. Make sure the connector is properly seated and latched.

10. Plug the 5-pin power connector into the motor. Even though the plug is keyed, **OBSERVE THE PROPER ORIENTATION. DO NOT FORCE THE CONNECTOR.** It plugs in very easily when properly oriented. **REVERSING THIS PLUG WILL CAUSE IMMEDIATE FAILURE OF THE CONTROL MODULE.**

11. Final installation check. Make sure the motor is installed as follows:

- Motor connectors should be oriented between the 4 o'clock and 8 o'clock positions when the control is positioned in its final location and orientation.
- Add a drip loop to the cables so that water cannot enter the motor by draining down the cables. Refer to Figure 10.

The installation is now complete. Reapply the AC power to the HVAC equipment and verify that the new motor control module is working properly. Follow the manufacturer's procedures for disposition of the old control module.



**TABLE 4
FURNACE DATA**

Model Number	Burner Type	Furnace Type	Nozzle			Heating Input BTUH	Heating Output BTUH
			Size	Type	Pump Pressure		
FC085V42A	AFG	Counterflow	0.75 *	70° Hollow	100 PSIG	105,000	87,000
			0.65			91,000	76,000
			0.55			77,000	64,000
FH085V42A	AFG	Hi-Boy	0.75 *	70° Hollow	100 PSIG	105,000	87,000
			0.65			91,000	76,000
			0.55			77,000	64,000
FH110V48A	NX	Hi-Boy	0.85 *	60° Solid	150 PSIG	140,000	116,000
			0.75			119,000	99,000
FH110V60A	NX	Hi-Boy	0.85 *	60° Solid	150 PSIG	140,000	116,000
			0.75			119,000	99,000
FLF085V42A	AFG	Lo-Boy	0.75 *	70° Hollow	100 PSIG	105,000	87,000
			0.65			91,000	76,000
			0.55			77,000	64,000
FLF110V48A	NX	Lo-Boy	0.85 *	60° Solid	150 PSIG	140,000	116,000
			0.75			119,000	99,000
FLF110V60A	NX	Lo-Boy	0.85 *	60° Solid	150 PSIG	140,000	116,000
			0.75			119,000	99,000
FLR085V42A	AFG	Lo-Boy	0.75 *	70° Hollow	100 PSIG	105,000	87,000
			0.65			91,000	76,000
			0.55			77,000	64,000
FLR110V48A	AFG	Lo-Boy	1.00 *	70° Hollow	100 PSIG	140,000	116,000
			0.85			119,000	99,000
FLR110V60A	AFG	Lo-Boy	1.00 *	70° Hollow	100 PSIG	140,000	116,000
			0.85			119,000	99,000
FLR140V60A	AFG	Lo-Boy	1.25 *	70° Hollow	100 PSIG	175,000	145,000
			1.10			154,000	127,000

* Factory Installed Nozzle. Also shown are optional approved nozzle size/type.

BURNER SETUP AND ADJUSTMENT PROCEDURES

All oil burner installations should be performed by a qualified installer in accordance with regulations of the National Fire Protection Standard for Oil-Burning Equipment, NFPA31 -- latest edition, and in complete compliance with all local codes and authorities having jurisdiction. A qualified installer is an individual or agency who is responsible for the installation and adjustments of the heating equipment and who is properly licensed and experienced to install oil-burning equipment in accordance with all codes and ordinances. The proper installation and adjustment of any oil burner requires technical knowledge and the use of combustion test instruments. The following procedure must be followed to correctly adjust the burner to match the specific characteristics of the installation.

IMPORTANT

Always use combustion test instruments when making burner adjustments and draft gauge when setting the barometric damper. It is virtually impossible to make accurate and reliable adjustments using the "eyeball" method.

Check all oil lines and connections for leaks.
Connect pressure gauge by removing bleed fitting and screwing in pressure gauge. See Figure 12.

1. PREPARATION STEPS

- A. **Calibrate and Check Operation of Measuring Equipment** Follow manufacturer's recommended procedures for calibration and equipment check out.
- B. **Prepare Heating Unit for Testing** Drill two 1/4 inch holes in the flue between the heating plant and the barometric draft regulator. If space permits, the holes should be located in a straight section of the flue, at least two flue diameters from the elbow in the flue pipe and at least one diameter from the draft regulator. The purpose of the two holes in the flue pipe is to speed up testing and reduce instrument handling.
- C. **Clean and Seal Heating Plant** Make sure the burner blast tube, fan housing, and blower wheel are clear of dirt and lint. Seal any air leaks into the combustion chamber.
- D. **Nozzle Inspection** Annual replacement of nozzle is recommended. The nozzle size should match the design load. **DO NOT OVERSIZE.** (Determination of oversizing can be determined prior to your adjustment. If the firing rate should be reduced refer to Table 4.) Short cycles and low percent "on" time result in higher overall pollutant emissions and lower thermal efficiency. An in-line oil filter will reduce service problems due to nozzle clogging.

The filter should be located as close as possible to the oil burner. Care should be taken to prevent air leakage in the oil suction line. Use continuous runs of copper tubing and use minimum number of joints and fittings. Always use flare fittings.
- E. **Adjustment of Electrodes** Adjust ignition electrodes as specified in Figures 13A & 13B.
- F. **Operate Burner** Operate burner, adjust air setting for good flame by visual observation, and run for at least 10 minutes or until operation has stabilized.
- G. **Check Burner Pressure** Bleed air from pump and nozzle piping. Check pump pressure and adjust to nameplate pump pressure, if necessary.

2. COMBUSTION ADJUSTMENT STEPS

- H. **Set Draft** Check the draft reading over the fire with a draft gauge through a hole in the inspection door. The hole is above the flame level. Adjust the barometric draft regulator on the flue to give the over fire of $-.02$ " W.C.
- I. **Check Smoke Readings** After burner has been operating 5 or 10 minutes, take a smoke

measurement in the flue, following the smoke tester instructions. Oily or yellow smoke spots on the filter paper are usually a sign of unburned fuel, indicating very poor combustion (and likely high emissions of carbon monoxide and unburned hydrocarbons). This condition can sometimes be caused by too much air, or by other factors. If this condition cannot be corrected, major renovation or even burner replacement may be necessary.

- J. **Develop Smoke - CO₂ Curve** Record measurements of smoke and CO₂ from the flue. Then establish the smoke - CO₂ curve by taking readings over a range of air settings, as shown in Figure 11.

To do this, start with the air gate set at nearly full open and then take smoke and CO₂ readings at progressively lower air settings, as necessary to visualize the general shape of the curve. (The CO₂ readings will increase as the air setting is decreased, unless combustion is incomplete.) Do not set the air gate to give a smoke reading above No. 4 or No. 5. Plot the points on graph paper, as in Figure 11. Usually 3 or 4 readings are enough to establish the curve.

In adjusting each air setting, it is helpful to note the various positions of air gate at which measurements are made so that the final setting can be located quickly.

- K. **Adjust Air Setting** Examine the smoke - CO₂ plot and, keeping in mind the curve of Figure 11, note the location of the "knee" where the smoke number begins to rise sharply. Noting the air gate position marks, adjust the air setting to a CO₂ level 1/2 to 1 percent lower than the CO₂ level at the "knee". (This provides a tolerance against possible shifts in the setting over a period of time.) Do not increase the air setting any more than necessary on the lower portion of the curve below the "knee".

The characteristic curve for some burners may not yield a distinct "knee" in the curve. In such cases, the setting should be made near the minimum smoke, (using judgement).

Lock the air adjustment and repeat draft, CO₂ and smoke measurements to make sure the setting has not shifted.

3. COMBUSTION DIAGNOSIS

- L. **Check Performance** A well-matched and well-tuned burner should be capable of operation with smoke not greater than No. 2 and at a CO₂ level not less than 10%.

If this cannot be reached, check the following:

1. Air leaks into the combustion chamber or heat exchanger can dilute the combustion gases and prevent normal CO₂ readings. Such leaks should be sealed with furnace cement or other high-temperature sealant.

To check for dilution by leakage, measure the CO₂ at as high a point as possible over the fire, using a stainless steel tube inserted through the fire door sample hole (as described earlier for overfire draft measurements), and compare this with the CO₂ measured in the flue. A difference of more than 1 percent CO₂ between the flue and overfire reading usually indicates air entry through leaks that have not been properly sealed.

Seal between the probe and inspection door sample hole during test. The inspection door hole should be sealed when not being used to avoid leakage of air through it. (See Step H.)

2. If the CO₂ level of 10% cannot be reached without exceeding No. 2 smoke, poor mixing of air and fuel is likely.

It may be necessary to replace the combustion head or try different settings.

4. FINAL CHECKS

- M. **Measure Stack Temperature** Operating the unit at an excessive firing rate will generate more heat than the heat exchanger can utilize and result in unnecessary heat loss up the chimney. Other causes of excessive heat loss are badly sooted heat exchanger surfaces and excessive draft. The temperature of the flue gas provides an indication of these heat losses.

Measure flue temperature by subtracting the room air temperature from the thermometer reading. Excessive stack loss is indicated if the net stack temperature during steady operation exceeds 600°F.

- N. **Check Ignition** Check operation over repeated cycles to ensure prompt ignition on starting.
- O. **Check Pump Cutoff** Slow pump cutoff at the end of a firing cycle can cause smoke and other pollutant emissions. Check for prompt pump cutoff by observing flame or by testing smoke at shutdown. If poor cutoff is observed, make sure air is purged from the pump and nozzle line. Air trapped in the pump or nozzle line will expand when heated, thus causing oil to drip into the combustion chamber after shutdown. If poor cutoff persists, repair or replace pump. Also make sure the pump solenoid is working - if not replace.

SHORT FORM ADJUSTMENT PROCEDURE

Some burner service organizations may wish to perform a shorter procedure for the adjustment of oil burners. The following is an example of such a short form prepared by the National Association of Oil Heat Service Managers.

1. SERVICE AND CLEAN BURNER

Follow company procedure to complete the cleaning and servicing. Operate burner for ten minutes while tools are gathered and are cleaned.

2. CHECK DRAFT

Set draft regulator, if necessary. Regulator should be adjusted to achieve a -.02" W.C. over fire condition. The more restricted and lengthy the flue, the higher the draft necessary to obtain the accepted over fire conditions.

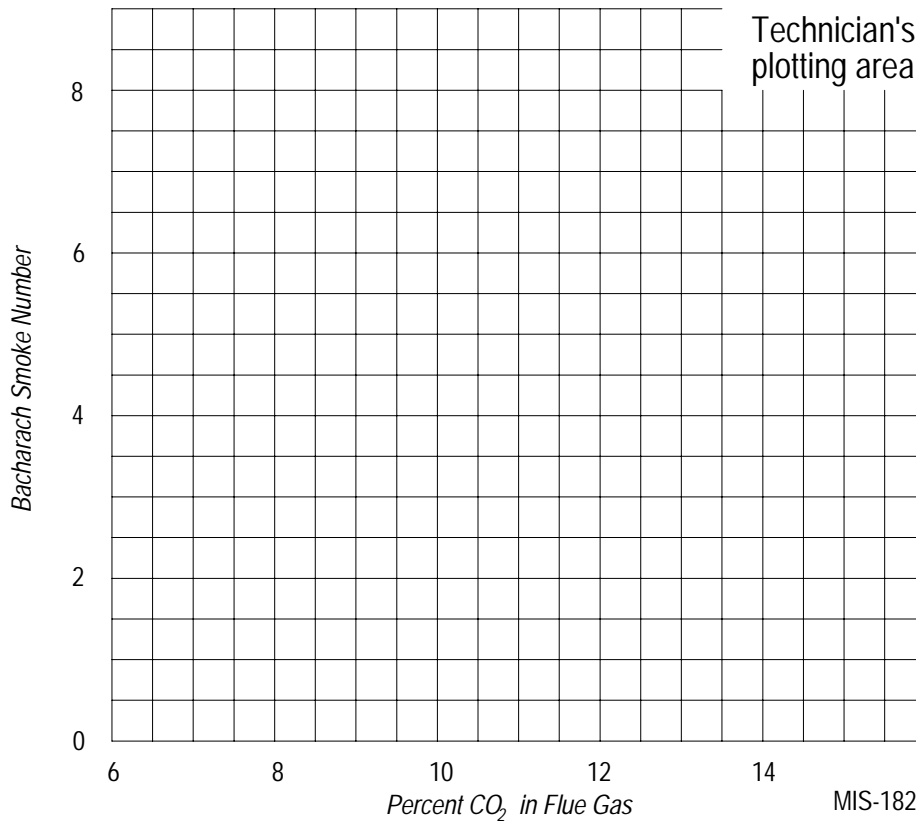
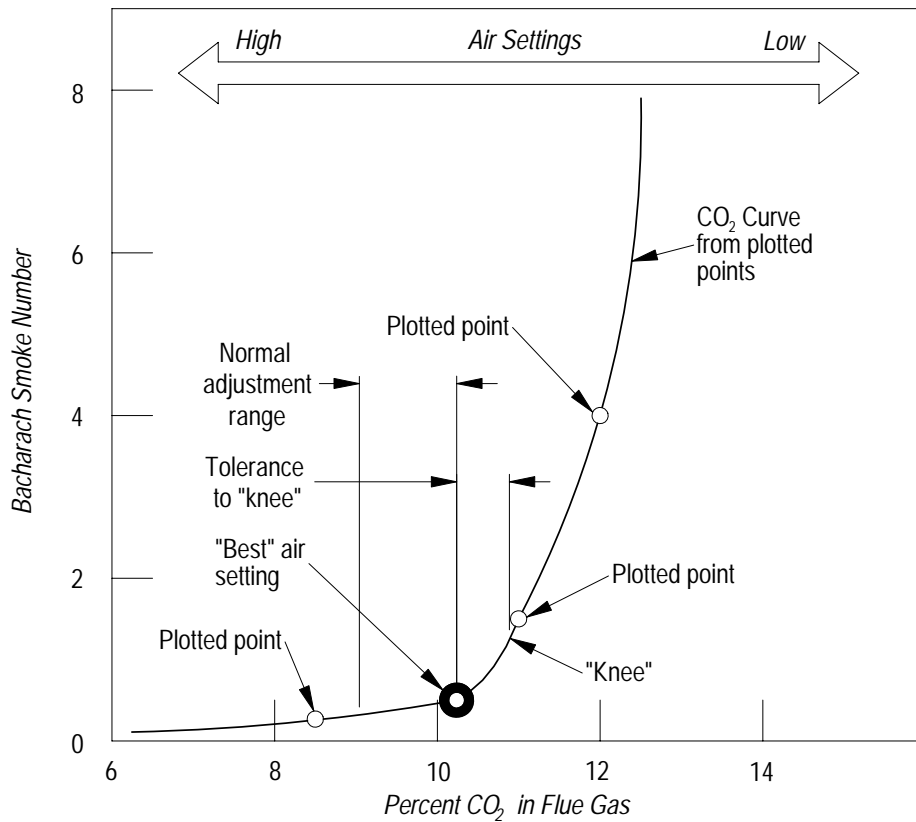
3. SMOKE TEST

Follow the instructions of the manufacturer of the smoke tester and take a smoke sample. Adjust the air to obtain a preliminary reading of about No. 3 spot. Then readjust the air to obtain the lowest possible reading, but do not open the air adjustment more than absolutely necessary to obtain a trace or No. 0 spot.

4. CO₂ TEST

Check CO₂ levels. This level should be between 10% and 12%.

FIGURE 11
TYPICAL SMOKE – CO₂ CHART WITH ADJUSTMENT RANGE



MIS-1827

FIGURE 12
PRESSURE GAUGE CONNECTION TO BLEED PORT

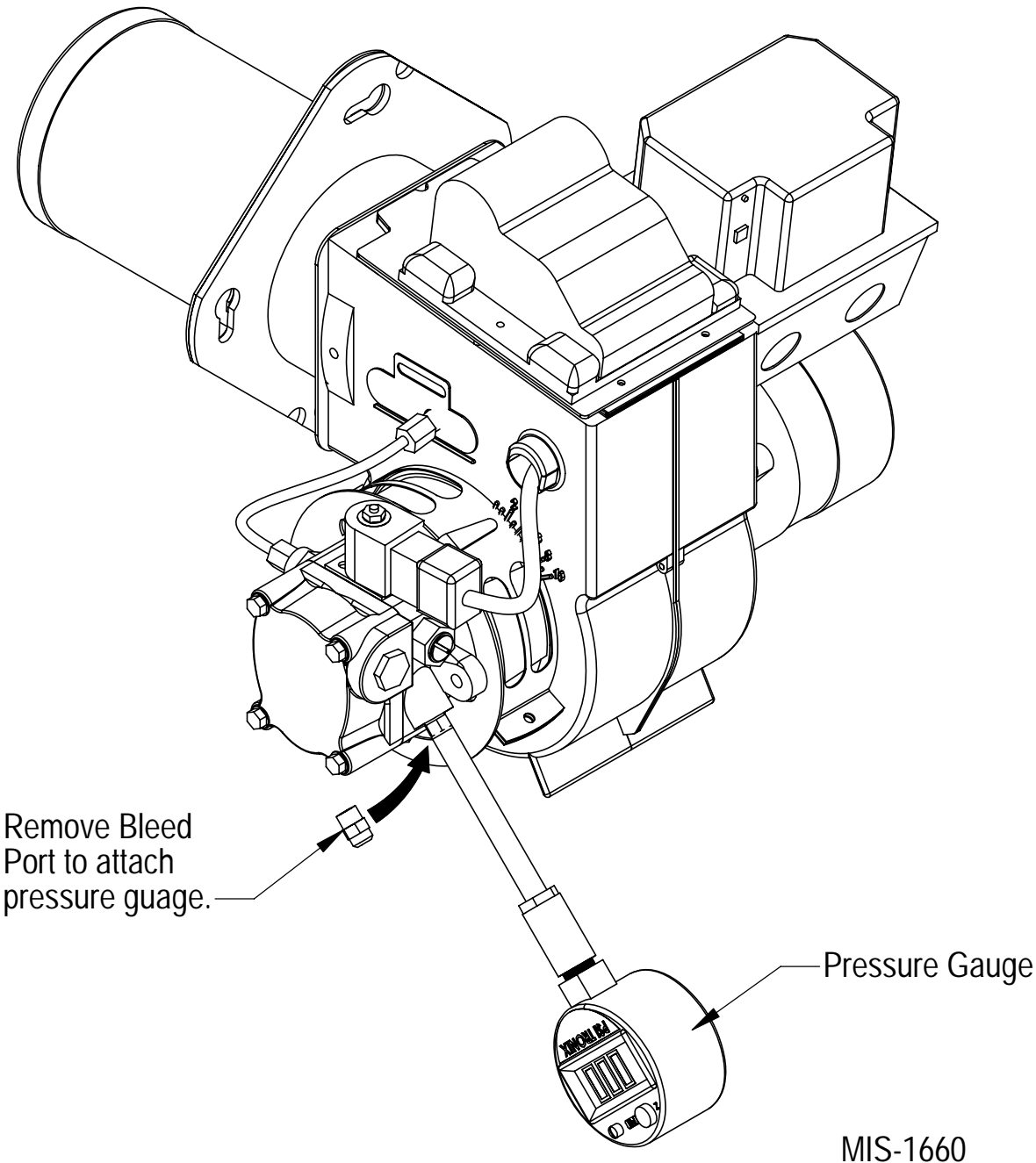


TABLE 5 — CORRELATION OF PERCENT OF CO₂, O₂ AND RESERVE AIR

Carbon Dioxide	Oxygen	Reserve Air (Approx.)
15.4	0.0	0.0
15.0	0.6	3.0
14.5	1.2	6.0
14.0	2.0	10.0
13.5	2.6	15.0
13.0	3.3	20.0
12.5	4.0	25.0
12.0	4.6	30.0
11.5	5.3	35.0
11.0	6.0	40.0
10.5	6.7	45.0
10.0	7.4	50.0

TABLE 6 — NO. 2 FUEL OIL EFFICIENCY CHART (NET STACK TEMP. DEGREES F)

% O ²	200	250	300	350	400	450	500	550	600	650	700	750	800	% O ²
1	89.6	88.4	87.3	86.2	85.1	84.0	82.9	81.7	80.6	79.5	78.4	77.3	76.2	14.7
2	89.4	88.2	87.0	85.9	84.7	83.6	82.4	81.2	80.1	78.9	77.7	76.6	75.4	14.0
3	89.2	87.9	86.7	85.5	84.3	83.1	81.9	80.7	79.4	78.2	77.0	75.8	74.6	13.2
4	88.9	87.7	86.4	85.1	83.8	82.6	81.3	80.0	78.7	77.5	76.2	74.9	73.6	12.5
5	88.7	87.3	86.0	84.6	83.3	82.0	80.6	79.3	77.9	76.6	75.3	73.9	72.6	11.7
6	88.4	87.0	85.5	84.1	82.7	81.3	79.9	78.5	77.0	75.6	74.2	72.8	71.4	11.0
7	88.0	86.5	85.0	83.5	82.0	80.5	79.0	77.5	76.0	74.5	73.0	71.5	70.0	10.3

TABLE 7 — RECOMMENDED START-UP SETTINGS

Model Number	Burner Style Part No.	Nozzle			Air Band Setting	Air Shutter Setting	Air Adjustment Plate Setting
		Size	Type	Pump Pressure			
FC085V42A	AFG/9020-040	0.75 *	70° Hollow	100 PSIG	0	6	—
		0.65			0	5	—
		0.55			0	5	—
FH085V42A	AFG/9020-040	0.75 *	70° Hollow	100 PSIG	0	6	—
		0.65			0	5	—
		0.55			0	5	—
FH110V48A	NX/9020-044	0.85 *	60° Solid	150 PSIG	—	—	3.75
		0.75			—	—	3
FH110V60A	NX/9020-044	0.85 *	60° Solid	150 PSIG	—	—	3.75
		0.75			—	—	3
FLF085V42A	AFG/9020-040	0.75 *	70° Hollow	100 PSIG	0	6	—
		0.65			0	5	—
		0.55			0	5	—
FLF110V48A	NX/9020-044	0.85 *	60° Solid	150 PSIG	—	—	3.75
		0.75			—	—	3
FLF110V60A	NX/9020-044	0.85 *	60° Solid	150 PSIG	—	—	3.75
		0.75			—	—	3
FLR085V42A	AFG/9020-041	0.75 *	70° Hollow	100 PSIG	0	6	—
		0.65			0	5	—
		0.55			0	5	—
FLR110V48A	AFG/9020-042	1.00 *	70° Hollow	100 PSIG	2	10	—
		0.85			0	8	—
FLR110V60A	AFG/9020-042	1.00 *	70° Hollow	100 PSIG	2	10	—
		0.85			0	8	—
FLR140V60A	AFG/9020-043	1.25 *	70° Hollow	100 PSIG	0	8	—
		1.10			0	6	—

* Factory Installed Nozzle. Also shown are optional approved nozzle size/type.

SPACING OF ELECTRODES

The electrodes should be spaced $5/32$ " apart. They should extend $1/16$ " beyond the end and $5/16$ " above the center of the nozzle tip as shown in Figures 13A & 13B.

GUN ASSEMBLY ADJUSTMENT

The gun assembly can be adjusted in the slot inside of fan housing by loosening screw holding slot cover in position. Nozzle tip should ordinarily be located $1-1/8$ " behind the front face of the cone.

REMOVING GUN ASSEMBLY

Disconnect the oil line at the fan housing and remove lock nuts on copper tube fitting. Loosen igniter hold down clamps, then swing igniter up and backward. Gun assembly can now be removed through this opening.

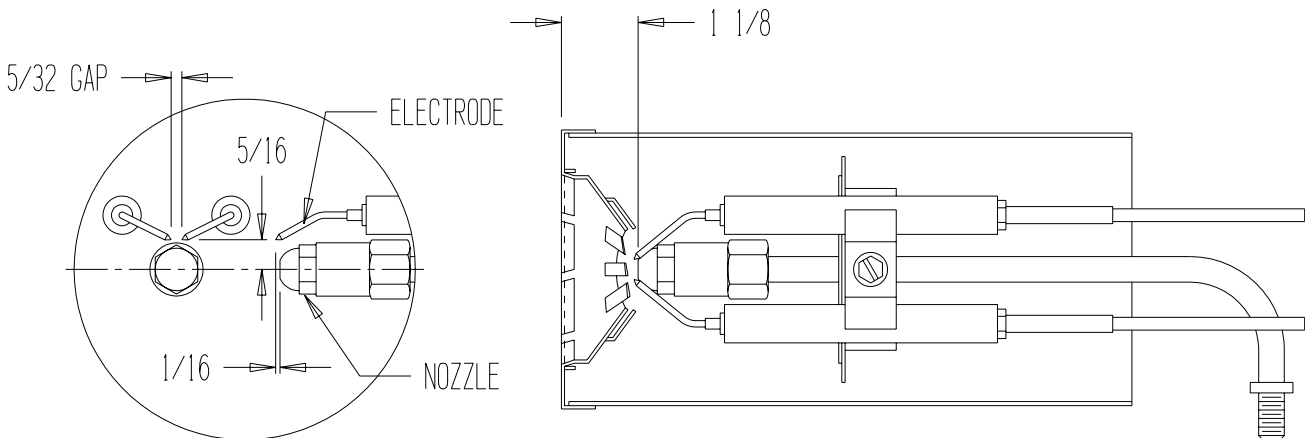
COMBUSTION AIR REQUIREMENTS

This furnace must be installed in a location where a sufficient supply of combustion air is available for the complete combustion of the fuel oil. Keep in mind that a certain amount of excess air is required as well to ensure complete combustion of the fuel oil.

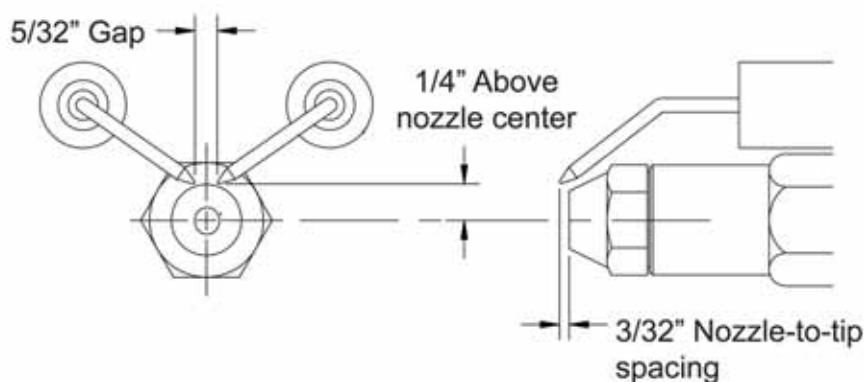
When structures are constructed too tightly to supply sufficient combustion air, air from outside the structure is required to be brought in directly to the furnace. This furnace has been conveniently designed to accept a combustion air boot which is attached directly to the outdoors by means of a 4" pipe. This pipe can be rigid or flexible, but it is recommended that a metallic material be used. Refer to Figure 14. The air boot used for this design is a Field Controls model number CAS-2B-90E that can be purchased through your local distributor. Follow all installation procedures as specified in the instructions packaged with the air boot kit.

NOTE - This accessory is not currently available for Bard Models: FH110V48A, FH110V60A, FLF110V48A and FLF110V60A with NX burners.

**FIGURE 13A
ELECTRODE ADJUSTMENTS — AFG BURNERS**

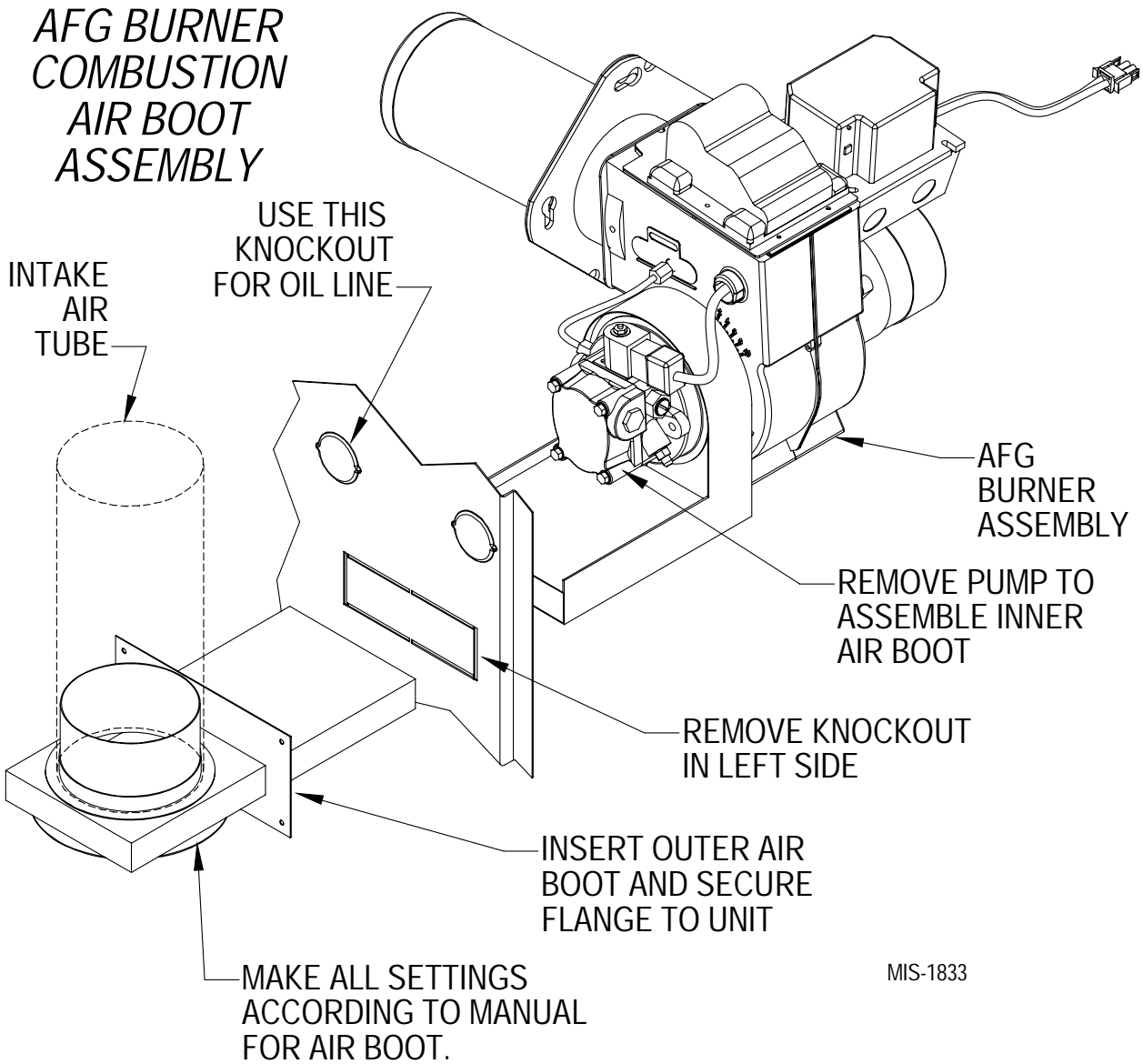


**FIGURE 13B
ELECTRODE ADJUSTMENTS — NX BURNERS**



MIS-160

**FIGURE 14
COMBUSTION AIR BOOT ASSEMBLY**



Note: *This accessory is not currently available for Bard Models:
FH110V48A, FH110V60A, FLF110V48A, FLF110V60A with NX Burners*

APPLIANCES LOCATED IN CONFINED SPACES

In unconfined spaces in buildings, infiltration may be adequate to provide air for combustion, ventilation, and dilution of flue gases. However, in buildings of unusually tight construction, additional air shall be provided using the method described under “All Air From Outdoors” in Figure 16.

An unconfined space (such as an open basement) must have a minimum volume of 50 cubic feet per 1,000 BTUH of total of *all* appliances in area. Adjoining rooms may be counted as one area only if there are not doors between the rooms.

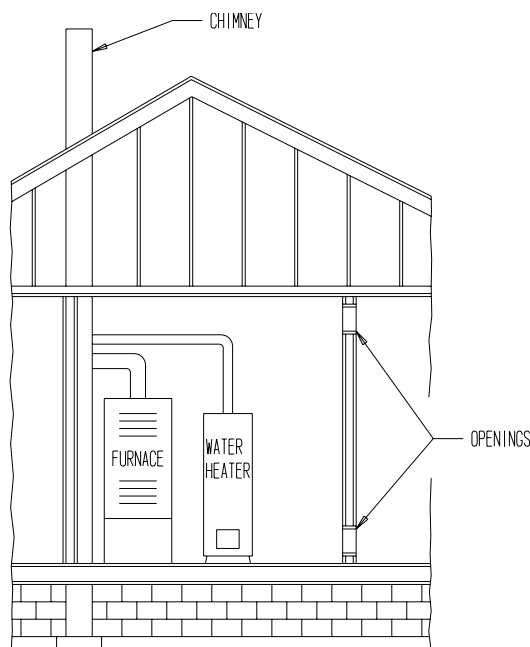
Shown in Table 8 are the required minimum areas in square feet to qualify as an unconfined space for various total BTUH input ratings. The table is based on a room(s) with 8 foot ceiling heights.

If the unconfined space is within a building having insufficient air because of tight construction, the air for combustion and ventilation shall be obtained from outdoors or from spaces freely communicating with the outdoors. Under these conditions a permanent opening or openings have a total free area of not less than one square inch per 5,000 BTU per hour (28 square inches per hour) of total input rating of all appliances shall be provided. For combustion air options see “Combustion Air Requirements”.

**TABLE 8
SQUARE FEET REQUIRED TO
QUALIFY AS UNCONFINED SPACE**

Total BTUH Input	Unconfined Space Minimum Area In Square Feet 8' Ceiling Height
60,000	375
80,000	500
85,000	531
105,000	656
115,000	719
120,000	750
140,000	875
145,000	906
160,000	1000
200,000	1250

**FIGURE 15
APPLIANCES LOCATED
IN CONFINED SPACES
ALL AIR FROM INSIDE THE BUILDING**



ALL AIR FROM INSIDE BUILDING

The confined space shall be provided with two permanent openings, one near the top of the enclosure and one near the bottom. Each opening shall have a free area of not less than one square inch per 1,000 BTU per hour (140 square inches per gallon per hour) of the total input rating of all appliances in the enclosure freely communicating with interior areas having in turn adequate infiltration from the outside. (See Figure 15.) Also see Table 9 on the following page for specific ventilation opening requirements for the furnace only.

The flow of combustion and ventilating air must not be obstructed from reaching the furnace.

NOTE: *Each opening shall have a free area of not less than one square inch per 1,000 BTU per hour (140 square inches per gallon per hour) of the total input rating of all appliances in the enclosure.*

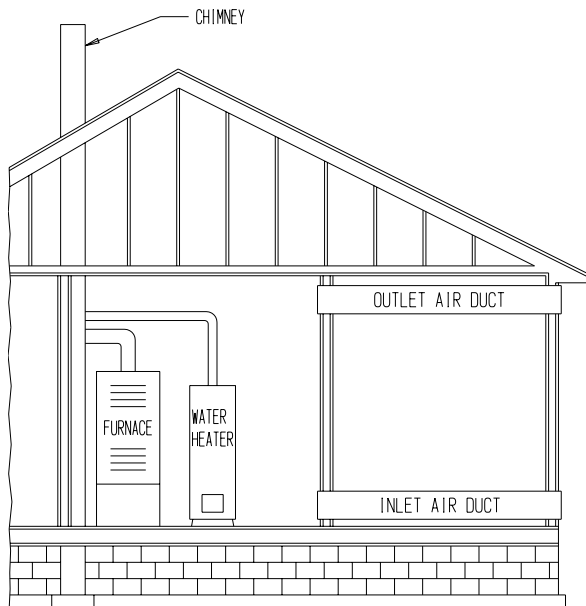
**TABLE 9
MINIMUM VENTILATION OPENINGS**

Model	Min. Ventilation Opening Square Inch	Recommended Opening (2 Required)	
		Size	Sq. In.
FH085V42A	240	8 x 16	128
FH110V48A	280	9 x 18	162
FH110V60A	280	9 x 18	162
FLF085V42A	290	8 x 19	152
FLR085V42A	290	8 x 19	152
FLF110V48A FLF110V60A	340	9 x 19	171
FLR110V48A FLR110V60A	340	9 x 19	171
FLR140V60A	360	9.5 x 19	180
FC085V42A	240	8 x 16	128

ALL VENTILATION AIR FROM OUTDOORS

- A. The confined space shall be provided with two permanent openings, one in or near the top of the enclosure and one in or near the bottom. The openings shall communicate directly, or by means of ducts with outdoors or to such spaces (crawl or attic) that freely communicate with outdoors. (See Figures 16, 17, & 18.)
- B. When directly communicating with outdoors or by means of vertical ducts, each opening shall have a free area of not less than one square inch per 4,000 BTU per hour (35 square inches per gallon per hour) of total input rating of all appliances in the enclosures. If horizontal ducts are used, each opening shall have a free area of not less than one square inch per 2,000 BTU per hour (70 square inches per gallon per hour) of total input of all appliances in the enclosure.

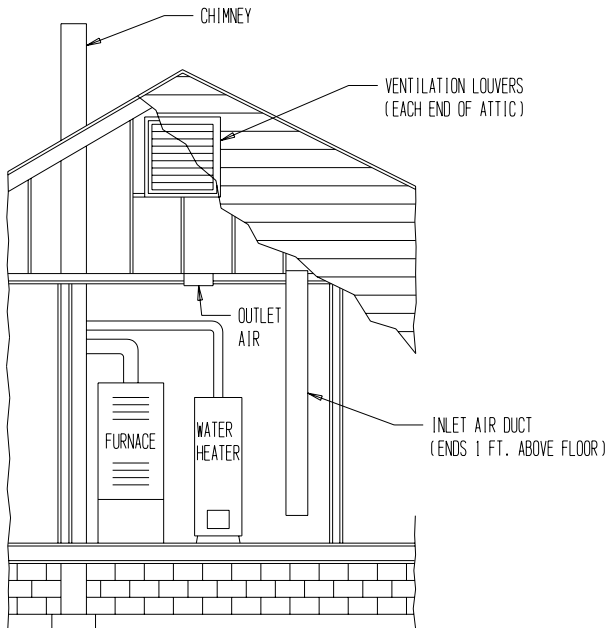
**FIGURE 16
APPLIANCES LOCATED IN CONFINED SPACES
ALL AIR FROM OUTDOORS**



NOTE: Each air duct opening shall have a free area of not less than one square inch per 2,000 BTU per hour (70 square inches per gallon per hour) of the total input rating of all appliances in the enclosure.

MIS-1337

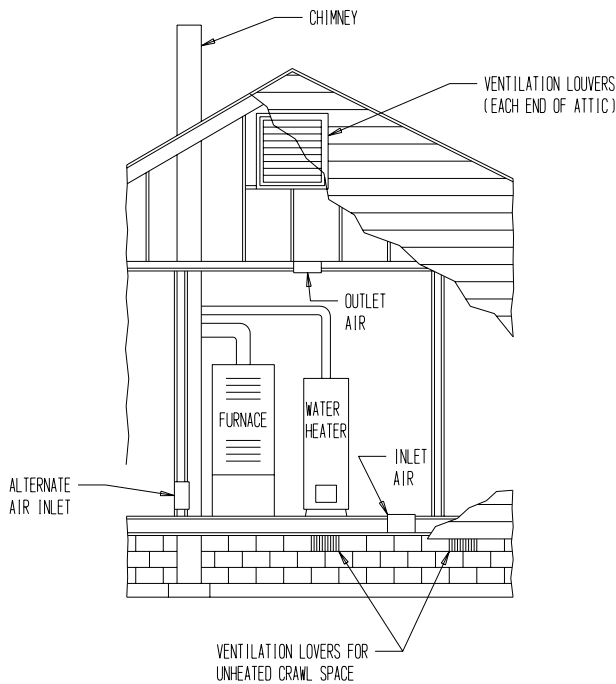
**FIGURE 17
 APPLIANCES LOCATED IN CONFINED SPACES
 ALL AIR FROM OUTDOORS THROUGH VENTILATED ATTIC**



NOTE: The inlet and outlet air openings shall each have a free area of not less than one square inch per 4,000 BTU per hour (35 square inches per gallon per hour) of the total input rating of all appliances in the enclosure.

MIS-1338

**FIGURE 18
 APPLIANCES LOCATED IN CONFINED SPACES
 ALL AIR FROM OUTDOORS
 INLET AIR FROM VENTILATED CRAWL SPACE AND OUTLET AIR TO VENTILATED ATTIC**



NOTE: The inlet and outlet air openings shall each have a free area of not less than one square inch per 4,000 BTU per hour (35 square inches per gallon per hour) of the total input rating of appliances in the enclosure.

MIS-1339

LOUVERS AND GRILLES

In calculating free area for ventilation and combustion air requirements, consideration shall be given to the blocking effect of louvers, grilles, or screens protecting openings. Screens used shall not be smaller than 1/4 inch (6.3 mm) mesh and shall be readily accessible for cleaning. If the free area through a design of louver or grille is known, it shall be used in calculating the size opening required to provide the free area specified. If the design and free area is not known, it may be assumed that wood louvers will have 30-35 percent free area and metal louvers and grilles will have 60-75 percent free area.

VENTING OPTIONS

This furnace is designed to be vented conventionally into a vertical chimney or horizontally through a side wall with an optional Field Controls side wall power venting system.

Note that the FH, FC and FLF series furnaces have been designed to allow for bringing the vent system through the cabinet side for increased venting flexibility. To take advantage of this feature, simply remove the desired knockout from either side or top of unit and rotate flue box accordingly by removing four (4) screws under cleanout plate as shown in Figure 4. Make sure smoke pipe gasket is in place before reinstalling flue box screws.

VERTICAL VENTING

If the unit is to be vertically vented make sure the flue pipe from the furnace to the chimney is the same size diameter as the flue outlet of the furnace which is 6". The flue pipe must have no reductions in diameter, be made of a corrosion-resistant material having an upward pitch of 1/4" for every foot of horizontal run, and be made of material capable of handling temperatures up to 1800°F.

A barometric damper is supplied with the furnace and must be installed in the flue pipe observing the instructions packaged with the damper control. The barometric damper opening must be located in the same atmospheric pressure zone as the combustion air inlet to the furnace. The furnace **must not** be vented into the same chimney with any solid fuel burning appliance such as a wood burner or pellet burner. Masonry chimneys must be lined with a listed system or other approved material that will resist corrosion, softening or cracking from flue gas temperatures up to 1800°F. See Standard for Installation of Oil Burning Equipment NFPA31 latest edition and Standard for Chimneys NFPA211 latest edition for additional information.

HORIZONTAL VENTING

This furnace is designed to be horizontally vented through a side wall with an optional side wall power vent. The recommended side wall vent is the Field Controls model number SWG-4HDS for 085 and 110 models, and SWG-5S for 140 models only. This vent can be purchased through your local distributor. Follow all installation instructions packaged with the vented system.

THERMOSTAT

These furnaces are designed to be controlled with any 24V heating or heating/cooling thermostat. The heat/cool thermostats must be designed for independent heat/cool transformer circuits to assure that the 24V transformer built into the oil primary control does not conflict with the main furnace 24V transformer. The heat anticipator should be set at 0.20A. This is a nominal setting. The thermostat circuit should be checked to verify setting.

**TABLE 10
TEMPERATURE RISE RANGES, LIMIT CONTROL SETTINGS,
AND HEATING BLOWER SPEEDS**

Model Number	Burner Type	Nozzle			Rise Ranges	Maximum Outlet Air Temp (°F)	Heating Blower Tap
		Size	Type	Pump Pressure			
FC085V42A	AFG	0.75 *	70° Hollow	100 PSIG	60 - 90	200	A
		0.65			70 - 100		C
		0.55			70 - 100		D
FH085V42A	AFG	0.75 *	70° Hollow	100 PSIG	60 - 90	200	A
		0.65			70 - 100		C
		0.55			70 - 100		D
FH110V48A	NX	0.85 *	60° Solid	150 PSIG	60 - 90	200	A
		0.75			70 - 100		C
FH110V60A	NX	0.85 *	60° Solid	150 PSIG	60 - 90	200	A
		0.75			60 - 90		C
FLF085V42A	AFG	0.75 *	70° Hollow	100 PSIG	60 - 90	200	A
		0.65			60 - 90		C
		0.55			60 - 90		D
FLF110V48A	NX	0.85 *	60° Solid	150 PSIG	60 - 90	200	A
		0.75			60 - 90		C
FLF110V60A	NX	0.85 *	60° Solid	150 PSIG	60 - 90	200	A
		0.75			60 - 90		C
FLR085V42A	AFG	0.75 *	70° Hollow	100 PSIG	60 - 90	200	A
		0.65			60 - 90		C
		0.55			60 - 90		D
FLR110V48A	AFG	1.00 *	70° Hollow	100 PSIG	60 - 90	200	A
		0.85			60 - 90		C
FLR110V60A	AFG	1.00 *	70° Hollow	100 PSIG	60 - 90	200	A
		0.85			60 - 90		C
FLR140V60A	AFG	1.25 *	70° Hollow	100 PSIG	60 - 90	200	A
		1.10			60 - 90		C

* Factory Set Point.

AIR FILTERS

Only Lo-Boy models are shipped with air filters. Filter kits are available from your local distributor for Upflow and Counterflow models. Knockouts are provided in the sides of the FH series models to facilitate the cutting of the return openings.

The upflow filter kit part numbers are FR23 for a 16x25x1 filter size and FR24 for a 20x25x1 filter size. These filter kits come complete with the filter and all necessary brackets for installing on the furnace. Each comes with a washable aluminum mesh filter. When installing a five ton AC unit on the furnace, one FR24 or Two FR23 must be used due to the high airflow requirements. It is important to note that a minimum of one inch spacing is required between the filter and the unit side. Do not exceed 400 fpm for fiberglass (disposable) type filters and 575 fpm for washable type filters. See Figure 19.

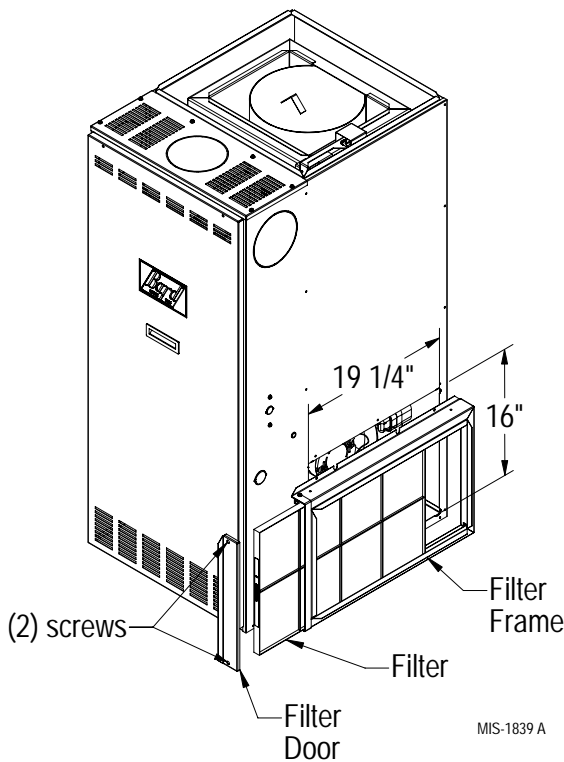
The counterflow filter kit part number FR25 comes with two washable filters. If not installing the FR25 kit remember not to exceed 400 fpm for fiberglass (disposable) type filters and 575 for washable type filters. See Figure 20.

See Table 11 for filter sizes and quantities.

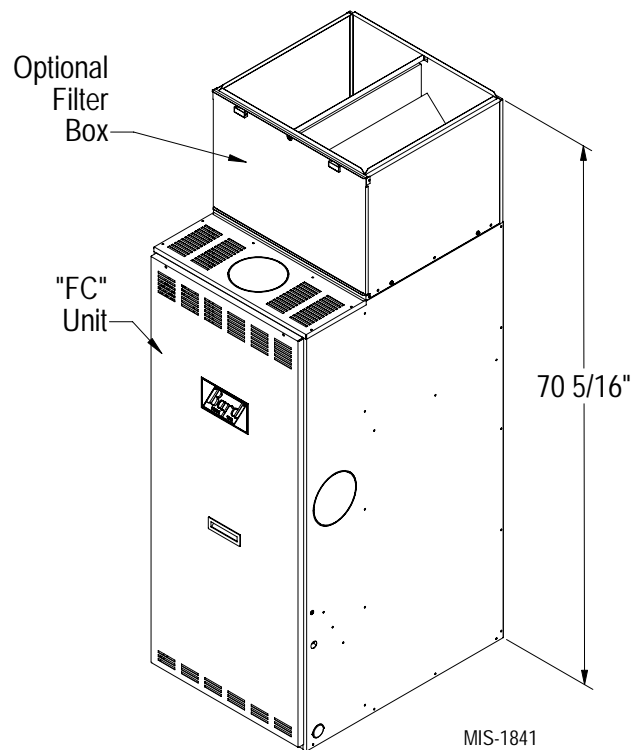
**TABLE 11
FILTER SIZES FOR OIL FURNACES**

Model	Size
FH085V42A Hi-Boy	(1) 16 x 25 x 1
FH110V48A Hi-Boy	(1) 16 x 25 x 1
FH110V60A Hi-Boy	(1) 20 x 25 x 1
FLF085V42A FLR085V42A Lo-Boys	(1) 16 x 20 x 2
FLF110V48A FLR110V48A FLF110V60A FLR110V60A Lo-Boys	(1) 20 x 20 x 2
FLR140V60A Lo-Boy	(1) 20 x 25 x 2
FC085V42A Counterflow	(2) 16 x 20 x 1

**FIGURE 19
TYPICAL INSTALLATION OF FR26 AND
FR27 FILTER RACKS**



**FIGURE 20
TYPICAL INSTALLATION OF FR25
FILTER KIT**

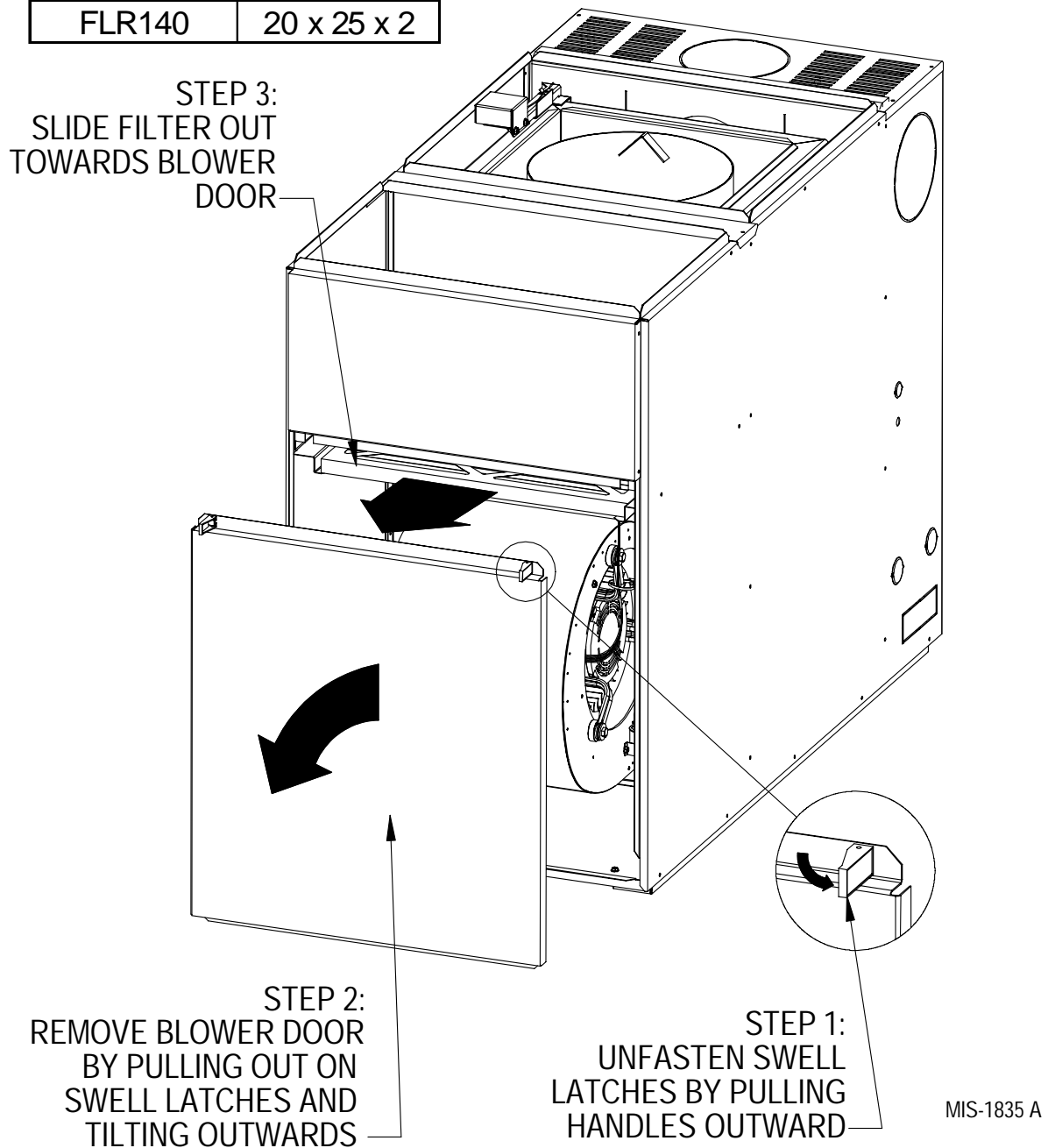


LO-BOY MODELS – FILTER LOCATIONS

Lo-boy models have the filter installed in the return air cabinet section of the furnace. It is accessible from the rear of the furnace by removing the blower/filter access door. The electrical switch should be turned “off” prior to removing the access door. Refer to Figure 21 below.

**FIGURE 21
FILTER INSTALLATION – LO-BOY MODELS**

UNIT	FILTER SIZE
FLF/FLR085	16 x 20 x 2
FLF/FLR110	20 x 20 x 2
FLR140	20 x 25 x 2



LUBRICATION

No lubrication is required for either the burner or the blower motor. Both are permanently lubricated.

INSPECT AIR FILTER

Replace filters before each heating season begins. It is recommended that filters also be replaced at least twice during the heating season.

Be sure the new filters are set securely in the filter rack so there can be minimal leakage around them.

FINAL INSPECTION AND TEST

Final inspection and test of an installation shall be made to determine that the work has been done in full accordance with regulations and according to the highest standards for safety, performance and appearance. Such an inspection and test should indicate the following as a minimum:

1. Determine that all parts of the oil storage and circulating system, including tank, piping and burner, are free from oil leaks. Be sure that no oil discharges from the nozzle when burner is not operating.
2. Be sure that the suction line and pump have been entirely vented of air so that the burner has instantaneous oil shutoff at the nozzle and so that the pump operates without an air noise.
3. Check the flame adjustment to determine that the flame is clear, quiet, free of odor and oil nozzle is of proper size for the furnace.
4. Test operation of burner by operating the thermostat. First, set the thermostat above room temperature. Burner should start. Second, set thermostat below room temperature. Burner will stop.
5. Check operation of burner primary control in accordance with manufacturer's instructions included with the control. Following is the method we recommend in checking the safety switch in this primary control.
 - A. Flame Failure – Simulate by shutting off oil supply manual valve while burner is on. Within 9 seconds the control will shut the burner down and flash a diagnostic code of 1/2 second on / 1/2 second off. Ignition and motor stop and oil valve closes.

- B. Ignition Failure – Test by closing oil supply while burner is off. Run through starting procedure. The primary control will attempt three trials for ignition. After three attempts, the control will lockout.
- C. Power Failure – Turn off power supply while burner is on. When burner goes out, restore power and burner will restart.
- D. If operation is not as described, check wiring and installation first. If trouble appears to be in the control circuit, replace the flame detector. If trouble still persists, refer to "Common Causes of Trouble" section.

SERVICE HINTS

Preventive maintenance is the best way to avoid unnecessary expense, inconvenience, and retain operating efficiency of your furnace. It is advisable to have your heating system and burner inspected at periodic intervals by a qualified serviceman. If trouble develops, follow these simple checks before calling the serviceman.

1. Make sure there is oil in tank and valve is open.
2. Make sure thermostat is set above room temperature.
3. Make sure electrical supply to furnace is on and fuses are not blown or circuit breakers tripped.
4. Reset safety switch of burner primary control.



CAUTION

Reset three (3) times only. More than three resets can cause excessive oil to be pumped into combustion chamber which could result in explosion upon ignition.

5. Make sure air filters are in place and are clean.
6. Make sure all air openings in furnace, all ventilation and combustion air openings, all return air grilles, and all warm air registers are unobstructed and open.

COMBINATION COMBUSTION CHAMBER/BURNER MOUNTING SYSTEM

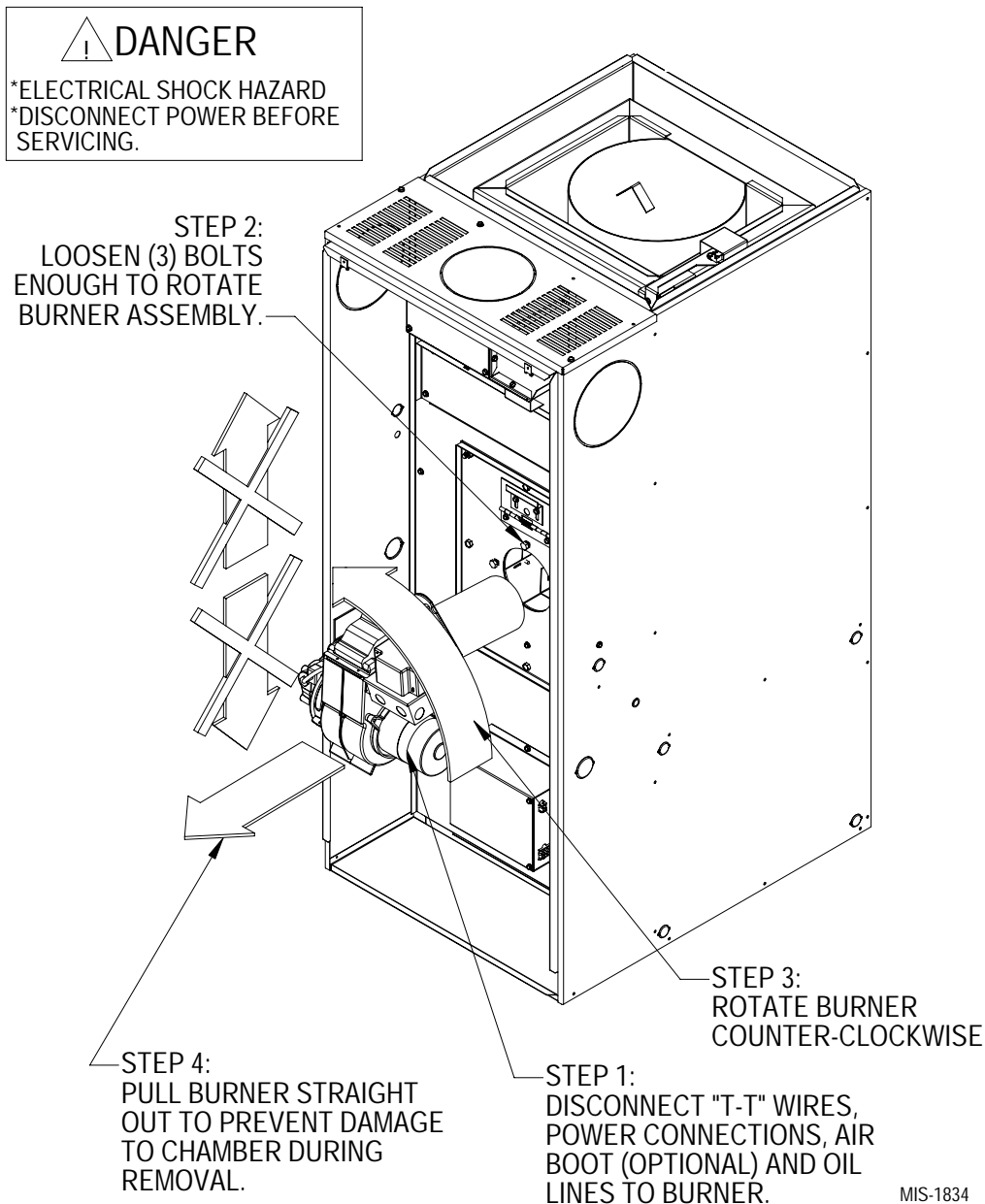
The furnace has been designed with a combustion chamber mounting system that enables service personnel to remove the combustion chamber, its mounting system, and burner assembly as one unit for inspection and/or service on the bench. It has also been designed to remove the burner assembly independently from the mounting system to perform basic annual service and inspection. The mounting system is completely adjustable so exact alignment between the burner tube and combustion chamber may be assured prior to installation into the furnace. See Figures 22 and 23.

WARNING

The procedures described in Figures 22 & 23 should be conducted only by a qualified service technician.

Improper servicing could cause electric shock hazard, fires or explosion resulting in damage, injury or death.

**FIGURE 22
REMOVAL OF BURNER ONLY**



MIS-1834

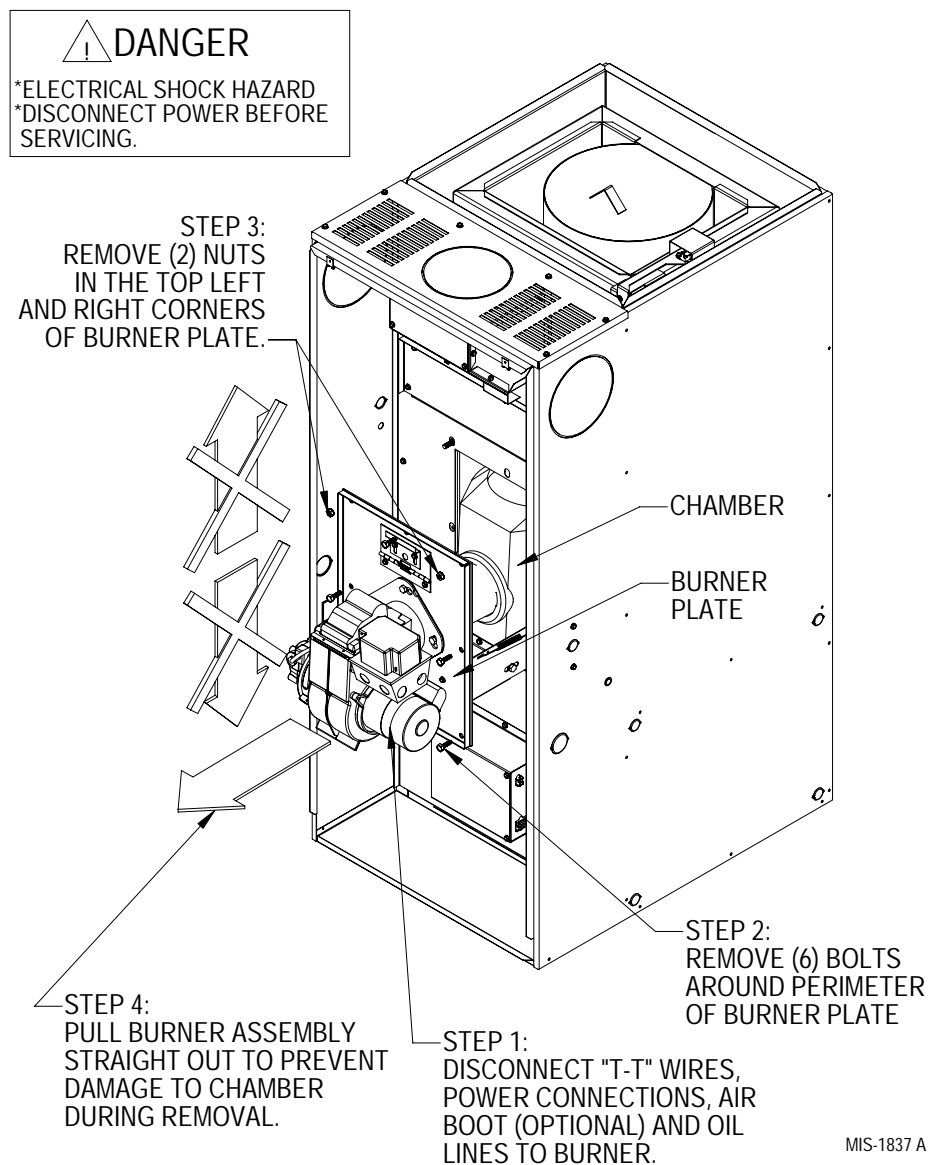
TO REMOVE BURNER ONLY

Disconnect fuel line, power cord and wires from T, T on primary control. Loosen (3) 1/4 inch bolts securing burner mounting flange. Twist burner counterclockwise and pull straight back away from the furnace. (See Figure 22.)

TO REMOVE THE ENTIRE COMBUSTION CHAMBER MOUNTING SYSTEM

Disconnect fuel line, power cord and wires from T, T on primary control. Remove (6) 5/16 inch bolts from around front plate. Next remove (2) 5/16 inch nuts from upper right and left hand corners of the front plate. Pull entire assembly straight back away from furnace. **BE CAREFUL NOT TO TIP ASSEMBLY UP OR DOWN AS IT MAY DAMAGE THE COMBUSTION CHAMBER.** (See Figure 23.)

FIGURE 23
REMOVAL OF ENTIRE COMBUSTION CHAMBER MOUNTING SYSTEM



COMMON CAUSES OF TROUBLE



CAUTION

To avoid accidents, always open main switch (OFF position) when servicing the burner.

BURNER WILL NOT PRODUCE FLAME

Check oil level gauge to see that there is sufficient oil in tank or tanks. Check the burner mounted relay control. *Do not adjust this control.*

Check position of electrodes – incorrect position will cause slow or delayed ignition. Clean electrodes and nozzle. Check and clean strainer in pump. If oil line filter is used, check filter condition.

If burner runs but there is no flame the fuel pump may be air bound. Follow instructions for bleeding fuel pump.

Check and make sure the solenoid valve on the oil pump is being energized and opening.

BURNER STARTS OR STOPS TOO OFTEN

Check heat anticipator setting on thermostat.

NOZZLE PRODUCES A STRINGY FLAME

Worn tangential grooves in nozzle. Replace nozzle.

BASEMENT TANK HUM

Occasionally with a two-pipe installation there may be a low return line hum. Eliminate hum by installing a special anti-hum valve in the return line near pump.

HEAVY FIRE OR PULSATING FLAME.

These may occur after burner starts. It may be caused by a slight oil leak in the fuel pump and cannot be corrected except by replacing the pump. This happens only when the burner is started.

CHATTERING SOUND OR HIGH PITCH NOISE

This noise from motor can usually be traced to where a conduit or BX cable is fixed rigidly or attached to some part of the building. Relieving this strain may eliminate noise.

PUMP SQUEALS OR CHATTERS

This may be caused by air in pipes. Check all joints in the oil supply pipe for leaks. Check strainer in pump; if dirty, clean.

INSUFFICIENT HEAT

Check limit control setting. It may be that flame is not allowed to stay on long enough to generate sufficient heat in furnace to heat the house properly. If the proper size furnace has been selected according to house requirements and satisfactory heat is not obtained, recheck the heating plant for size and capacity in relation to house. Check for clogged filters.

Check and make sure the heat anticipator on the thermostat is set correctly.

CARE OF FINISH

This furnace cabinet is made with a very durable and corrosion resistant finish. With normal cleaning it will last for many years.



WARNING

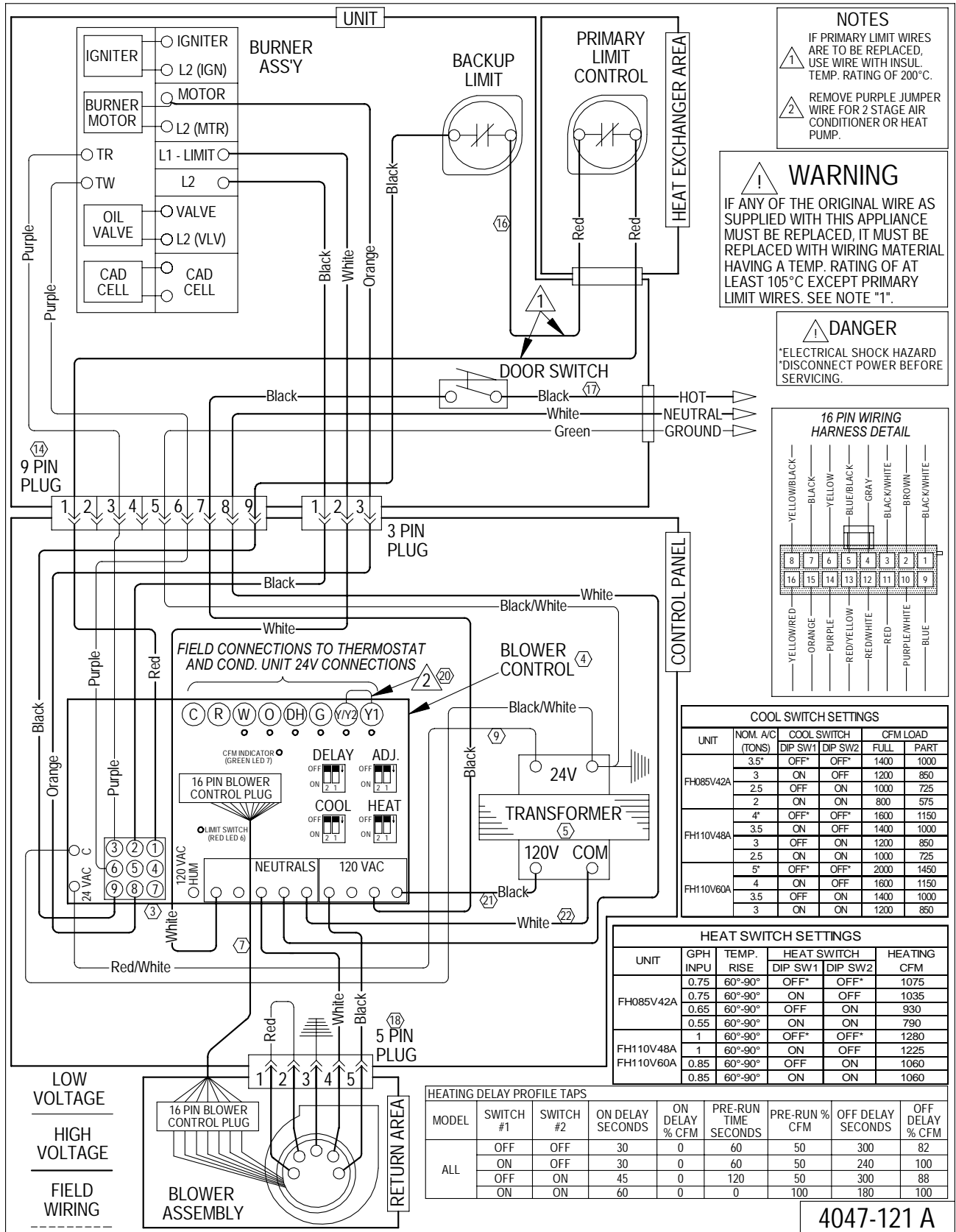
Under **no** circumstance should a soot deterioration device be used in the combustion chamber. These products known as “soot busters” or “soot sticks” are comprised of chemicals that burn at very high temperatures, which may exceed the temperature rating of the combustion chamber material.

Use of these products are detrimental to the life expectancy of the combustion chamber and will destroy the chamber. Refer to the “Cleaning of Furnace” section for proper cleaning methods.

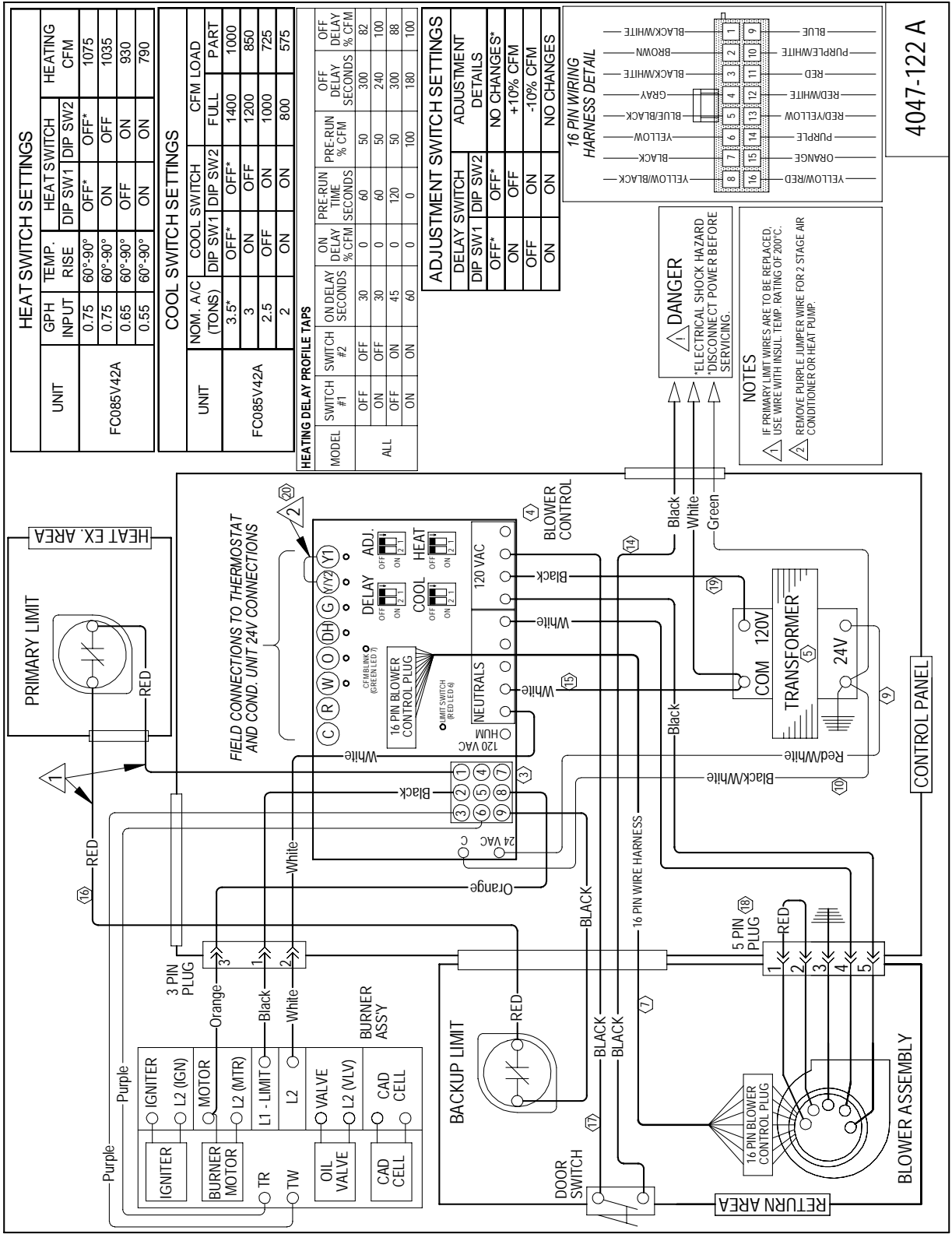
CLEANING OF THE HEAT EXCHANGER

All of these units have four clean out plugs for easy cleaning of the heat exchanger. They are accessible from the front and back of these units by removing the clean out access cover in the burner compartment and at the back of unit. The furnace should be checked annually by a qualified service technician.

FH SERIES WIRING DIAGRAM



FC SERIES WIRING DIAGRAM



4047-122 A