

---

# INSTALLATION INSTRUCTIONS

---

## SINGLE PACKAGE VARIABLE CAPACITY ENVIRONMENTAL CONTROL UNITS

### MODELS

**P60RV1-R**

**P72RV1-S**

**P72RV1-T**

**P60LV1-R**

**P72LV1-S**

**P72LV1-T**



Bard Manufacturing Company, Inc.  
Bryan, Ohio 43506

*Since 1914 . . . Moving ahead just as planned.*

Manual : 2100-542B  
Supersedes: 2100-542A  
File: Volume II Tab 10  
Date: 12-15-11

# CONTENTS

---

**Getting Other Informations and Publications ..... 3**

**General Instructions**

Important ..... 4  
Shipping Damage ..... 4  
General ..... 4  
Field Installed Heater Packages (Optional) ..... 4

**Installation**

Location ..... 10  
Slab Mounting ..... 10  
Typical Installations ..... 10 & 13  
Condensate Drain Trap ..... 13  
Air Filters ..... 13  
Wiring – Main Power ..... 14  
Wiring – 24V Low Voltage Control Circuit ..... 14  
Digital Thermostat/Controller ..... 14  
Wiring Diagram ..... 14

**Figures**

Figure 1A Unit Dimensions - Right Hand ..... 8  
Figure 1B Unit Dimensions - Left Hand ..... 9  
Figure 2 Slab Mounting at Ground Level ..... 11  
Figure 3 Airflow and Service Access  
Clearances ..... 11  
Figure 4 Elevated Mounting Platform ..... 12  
Figure 5 Condensate Drain Trap ..... 13  
Figure 6 Fan Blade Setting ..... 20  
Figure 7 Brazing Diagram ..... 22

**Start Up and Operation**

General ..... 15  
Topping Off System Charge ..... 15  
Safety Practices ..... 15  
Start Up Notes ..... 16  
High Pressure Switch ..... 16  
Three Phase Scroll Compressor Start Up  
Information ..... 16  
Phase Monitor ..... 16  
Service Hints ..... 16  
Digital Controller ..... 16  
Sequence of Operation ..... 17 & 18  
Lead/Lag Sequence ..... 18  
Compressor Control Module ..... 19  
Adjustments ..... 19

**Service and Troubleshooting**

Service Hints ..... 20  
Pressure Service Ports ..... 20  
Refrigerant Charge ..... 20  
Fan Blade Settings ..... 20  
Pressure Table ..... 21  
Suction and Discharge Tube Brazing ..... 22

**Tables**

Table 1 Rated CFM & ESP ..... 4  
Table 2 Electrical Specifications ..... 5  
Table 3 Opt. Field Installed Heater Packages ..... 6  
Table 4 Opt. Field Installed Elec. Heater ..... 7  
Table 5 Filter Requirements & Sizes ..... 13  
Table 6 Fan Blade Setting Dimensions ..... 20  
Table 7 Pressure Table ..... 21

# Getting Other Information and Publications

---

These publications can help you install the air conditioner or heat pump. You can usually find these at your local library or purchase them directly from the publisher. Be sure to consult current edition of each standard.

National Electrical Code ..... ANSI/NFPA 70

Standard for the Installation ..... ANSI/NFPA 90A  
of Air Conditioning and Ventilating Systems

Standard for Warm Air ..... ANSI/NFPA 90B  
Heating and Air Conditioning Systems

Load Calculation for ..... ACCA Manual J  
Residential Winter and Summer Air Conditioning

Duct Design for Residential ..... ACCA Manual D  
Winter and Summer Air Conditioning and Equipment  
Selection

## FOR MORE INFORMATION, CONTACT THESE PUBLISHERS:

**ACCA**    **Air Conditioning Contractors of America**  
1712 New Hampshire Ave. N.W.  
Washington, DC 20009  
Telephone: (202) 483-9370  
Fax: (202) 234-4721

**ANSI**    **American National Standards Institute**  
11 West Street, 13th Floor  
New York, NY 10036  
Telephone: (212) 642-4900  
Fax: (212) 302-1286

**ASHRAE** **American Society of Heating, Refrigerating,  
and Air Conditioning Engineers, Inc.**  
1791 Tullie Circle, N.E.  
Atlanta, GA 30329-2305  
Telephone: (404) 636-8400  
Fax: (404) 321-5478

**NFPA**    **National Fire Protection Association**  
Batterymarch Park  
P.O. Box 9101  
Quincy, MA 02269-9901  
Telephone: (800) 344-3555  
Fax: (617) 984-7057

# GENERAL INSTRUCTIONS

---

## IMPORTANT

The equipment covered in this manual is to be installed by trained, experienced service and installation technicians. All duct work, supply and return ducts, must be properly sized for the design airflow requirement of the equipment. ACCA is an excellent guide to proper sizing. All duct work or portions thereof not in the conditioned space should be properly insulated in order to both conserve energy and prevent condensation or moisture damage.

## SHIPPING DAMAGE

Upon receipt of equipment, the carton should be checked for external signs of shipping damage. If damage is found, the receiving party must contact the last carrier immediately, preferably in writing, requesting inspection by the carrier's agent.

## GENERAL

The refrigerant system is completely assembled and charged. All internal wiring is complete.

The unit is designed for use with or without duct work. Flanges are provided for attaching the supply and return ducts.

These instructions explain the recommended method to install the air cooled self-contained unit and the electrical wiring connections to the unit.

These instructions and any instructions packaged with any separate equipment required to make up the entire system should be carefully read before beginning the installation. Note particularly "Starting Procedure" and any tags and/or labels attached to the equipment.

While these instructions are intended as a general recommended guide, they do not supersede any national and/or local codes in any way. Authorities having jurisdiction should be consulted before the installation is made.

## FIELD INSTALLED HEATER PACKAGES (OPTIONAL)

These packaged air conditioners are manufactured without supplementary electric heaters. Supplementary heaters are available for simple, fast field installation.

A separate power circuit is required for the supplementary heaters.

**IMPORTANT:** Refer to Table 1 when designing duct work for maximum available static pressure with heater installed.

Refer to data shown in Table 3 and 4 for proper application information on all available heater combinations and what units they can be used with. It also shows the applicable circuit ampacities, fuse size, and wire size for each heater combination.

**TABLE 1**  
**RATED CFM AND EXTERNAL STATIC PRESSURE (ESP)**

Model No.	Rated CFM	Recommended Airflow Range	Rated ESP	Max. ESP
P60RV1	1700	850 - 1700	0.20	0.50
P60LV1	1700	850 - 1700	0.20	0.50
P72RV1	1700	850 - 1700	0.20	0.50
P72LV1	1700	850 - 1700	0.20	0.50

**NOTE:** ECM motors provide rated CFM up to 0.50 ESP

**NOTE:** See Indoor Blower Operation section on Page 17 for more details.

**TABLE 2  
SPECIFICATIONS**

<b>Model</b>	<b>P60RV1-R P60LV1-R</b>	<b>P72RV1-S P72LV1-S</b>	<b>P72RV1-T P72LV1-T</b>
<b>Electric Rating – Circuit A</b>	230/208-60-1 220/200-50-1	230/208-60-3 220/200-50-3	460-60-3 400-50-3
Operating Voltage Range	60 Hz 50 Hz	197 - 253 180 - 240	187 - 253 180 - 240
Minimum Circuit Ampacity	40	44	21
BCSC	25.7	28.5	12.9
Field Wire Size *	8	8	10
Ground Wire Size	8	8	10
Delay Fuse – Max. **	60A	60A	30A
Total unit Amps – 230/208	31.4 / 32.1	31.2 / 34.2	16.7
<b>Compressor – Circuit A</b>			
Compressor Type	Scroll	Scroll	Scroll
Volts	230/208-60-1 220/200-50-1	230/208-60-3 220/200-50-3	460-60-3 400-50-3
Rated Load Amps	23.9 / 24.6	23.7 / 26.7	12.9
Lock Rotor Amps	134 / 134	164 / 164	75
<b>Fan Motor and Condenser</b>			
Fan Motor – HP/RPM	1/2 - ECM	1/2 - ECM	1/2 - ECM
Fan Motor Amps	2.5	2.5	2.5
Fan – Dia./CFM	24"/3500	24"/3500	24"/3500
<b>Motor and Evaporator</b>			
Blower Motor – HP/RPM	3/4 - ECM	3/4 - ECM	3/4 - ECM
Blower Motor – Amps	5.0	5.0	5.0
CFM Cooling	1700	1700	1700
Charge (R-410 oz.)	432	400	400

**TABLE 3**  
**OPTIONAL FIELD INSTALLED HEATER PACKAGES**  
**ONLY TO BE USED WITH THE MODELS INDICATED**

Heater Package Model	Volts & Phase	P60RV1-R	P72RV1-S	P72RV1-T	P60LV1-R	P72LV1-S	P72LV1-T
EHP513-A05	240/208-1	X					
EHP513-A10	240/208-1	X					
EHP513-A15	240/208-1	X					
EHP513-B09	240/208-3		X				
EHP513-B15	240/208-3		X				
EHP513-A05L	240/208-1				X		
EHP513-A10L	240/208-1				X		
EHP513-A15L	240/208-1				X		
EHP513-B09L	240/208-3					X	
EHP513-B15L	240/208-3					X	
EHP513-C09	480-3			X			
EHP513-C15	480-3			X			
EHP513-C09L	480-3						X
EHP513-C15L	480-3						X

**TABLE 4  
OPTIONAL FIELD INSTALLED ELECTRIC HEATER TABLE**

Heater Package Model No.	Unit Volts Phases	Htr. KW & Capacity @ 240 Volts		Htr. KW & Capacity @ 208 Volts		240/208V Htr. Amps	Heater Internal Circuit Breaker	Circuit B				
		KW	BTUH	KW	BTUH			No. Field Circuits	③ Min. Circuit Ampacity	① Max. Over Current Protection	② Field Power Wiring	② Ground Wire Size
EHP513-A05/L	240/208-1	5	17,100	3.75	12,800	20.8/18.1	30/60	1	26/23	30/25	10/10	10
EHP513-A10/L	240/208-1	10	34,100	7.50	26,000	41.6/36.2		1	53/46	60/50	6/8	10
EHP513-A15/L	240/208-1	15	51,200	11.25	38,400	62.5/54.1		1	79/68	80/70	4/4	8
EHP513-B09/L	240/208-3	9	30,700	6.75	23,000	21.7/18.7	None	1	28/24	30/25	10/10	10
EHP513-B15/L	240/208-3	15	51,200	11.25	38,400	36.2/31.2		1	46/39	50/40	8/8	10
EHP513-C09/L	480-3	9	30,700			10.8	None	1	14	15	14	14
EHP513-C15/L	480-3	15	51,200			18		1	28	30	10	12

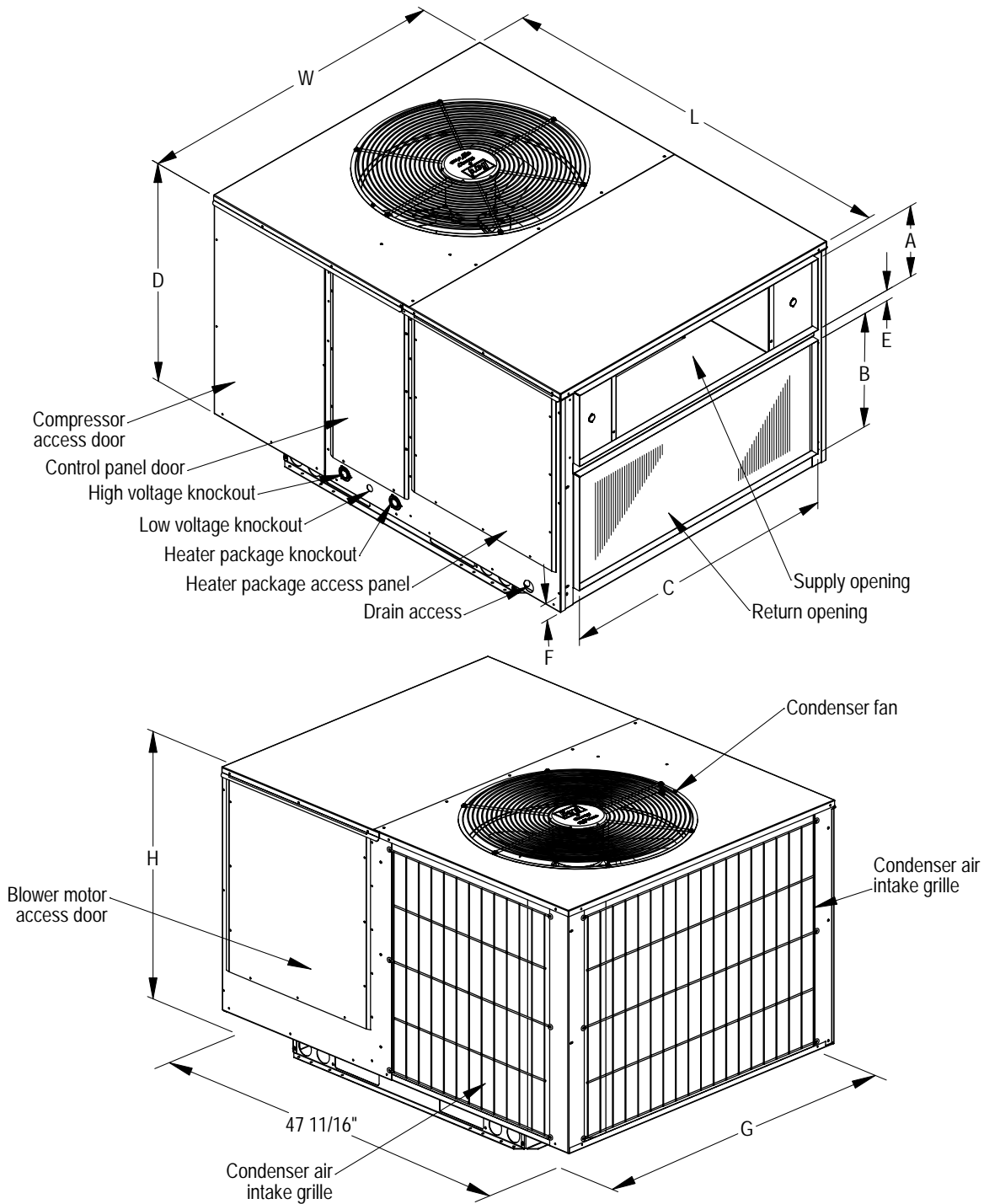
① Maximum size of the time delay fuse or HACR circuit breaker for protection of field wiring devices.

② Based on wire suitable for 75°C. Other wiring materials must be rated for marked "Minimum Circuit Ampacity" or greater. Based on 75°C copper wire. All wiring must conform to the National Electric Code and all local codes.

③ These "Minimum Circuit Ampacity" values are to be used for sizing the field power conductors. Refer to the National Electric Code (latest revision), Article 310 for power conductor sizing.

**IMPORTANT:** While this electrical data is presented as a guide, it is important to electrically connect properly sized fuses and conductor wires in accordance with the National Electrical Code and all existing local codes.

**FIGURE 1A  
DIMENSIONS OF RIGHT-HAND UNITS**



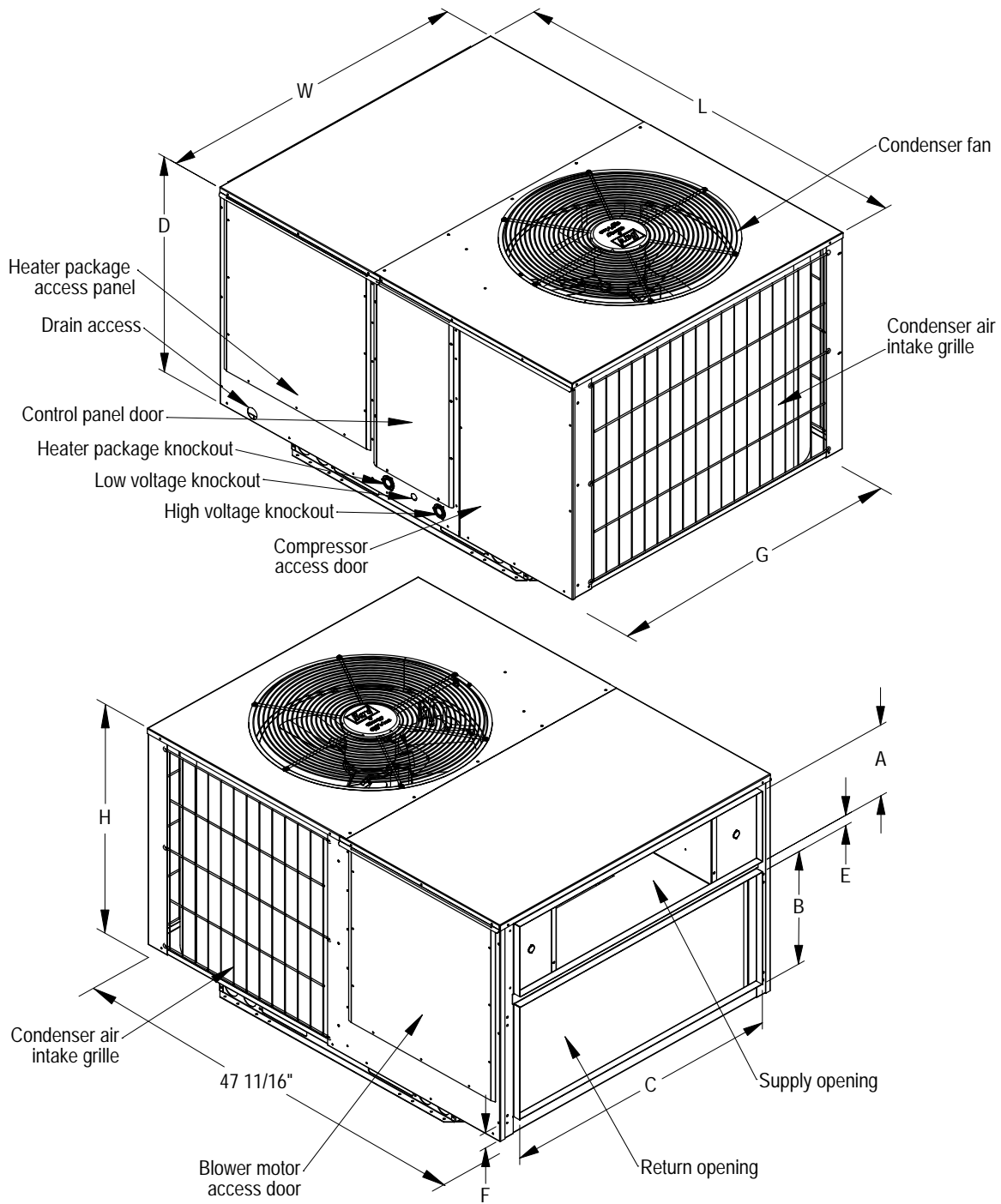
*Unit Dimension Chart*

Unit	Supply Size		Return Size		Unit Overall Dimensions			Unit General Dimensions			
	A	C	B	C	H (height)	L (length)	W (width)	D	E	F	G
P60/72RV1	9.875	37.875	15.875	37.875	33.25	55.25	42.375	30.25	1.5	2.375	38.125

MIS-2913



**FIGURE 1B  
DIMENSIONS OF LEFT-HAND UNITS**



*Unit Dimension Chart*

Unit	Supply Size		Return Size		Unit Overall Dimensions			Unit General Dimensions			
	A	C	B	C	H (height)	L (length)	W (width)	D	E	F	G
P60/72LV1	9.875	37.875	15.875	37.875	33.25	55.25	42.375	30.25	1.5	2.375	38.125

MIS-2912

# INSTALLATION

---

## LOCATION

### GENERAL

The unit must be located outside, or in a well ventilated area. It must not be in the space being heated or cooled. A sound absorbing material should be considered if the unit is to be installed in such a position or location that might cause transmission of sound or vibration to the living area or adjacent buildings.

### SLAB MOUNTING

A minimum of 24 inches should be provided between the coil inlet and any building surfaces. Provide a minimum of three feet clearance on the service access side of the unit. See Figure 2.

## TYPICAL INSTALLATIONS

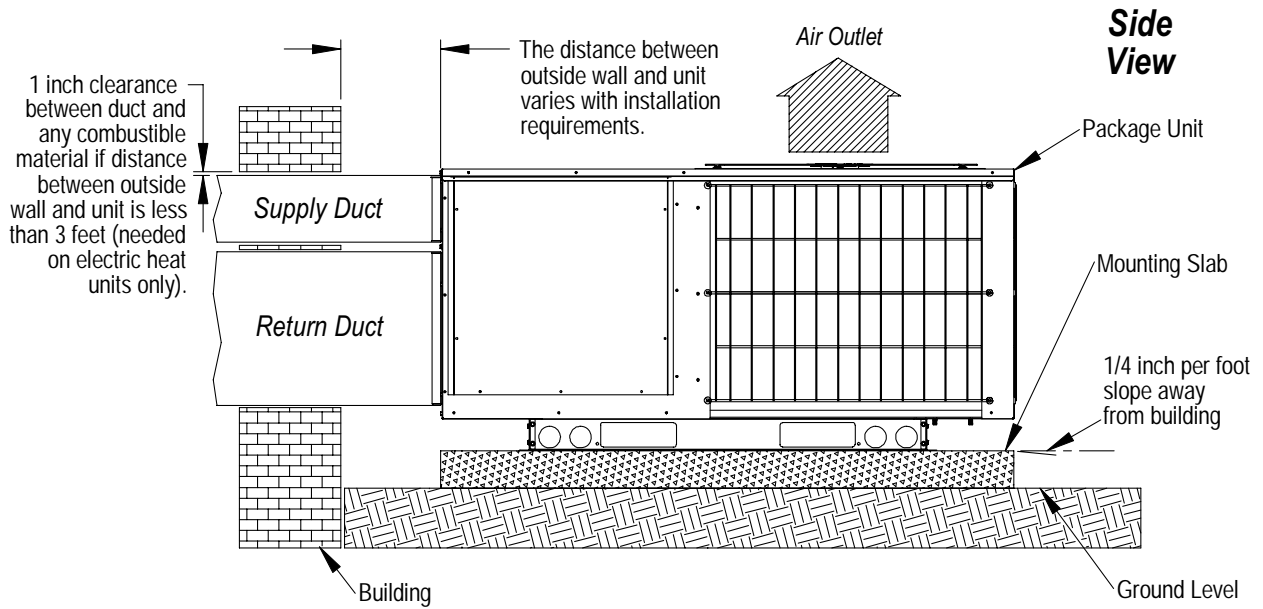
1. **ROOF MOUNTED** – The unit is mounted on a sturdy base on the roof of the building. Return air to the unit is brought through a single return grille (grilles with built-in filters are best since they enable easy access for filter changing). Return air ducts are attached to the lower section of the front panel. Supply air is brought from the unit to attic duct work or to a furred down hall. Supply air duct is attached to the top of the front panel.

*CAUTION: All outdoor duct work must be thoroughly insulated and weatherproofed. All attic duct work must be thoroughly insulated. Two inch thick insulation with suitable vapor barrier is recommended for both outdoor and attic runs.*

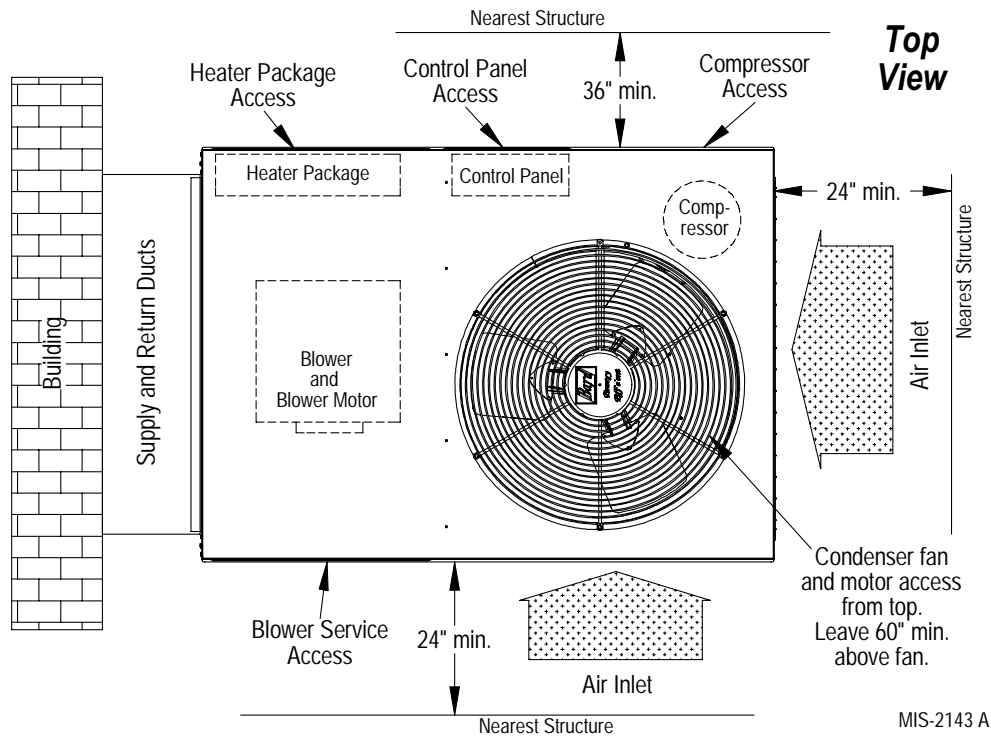
In roof top installation, as in all installations, the air conditioner must be level from side to side. However, the unit should have a pitch along the length to assure complete external drainage of precipitation and of defrost condensate.

2. **CRAWL SPACE** – Duct work installed in crawl space must be well insulated and provided with a vapor barrier. In addition, the crawl space must be thoroughly ventilated and provided with a good vapor barrier as a ground cover. It is most desirable to install units on the exterior of a building - rather than inside the crawlspace- to facilitate service access.
3. **SLAB MOUNTED AT GROUND LEVEL** – This type installation is ideal for homes with a slab floor construction where a roof mounted unit is not desired. The supply and return duct work can be run through a furred closet space.
4. **THROUGH THE WALL** – This type installation requires a suitable framework to be fabricated capable of withstanding the unit weight. Normally the unit will be installed so as to minimize supply and return duct work.

**FIGURE 2  
SLAB MOUNTING AT GROUND LEVEL**

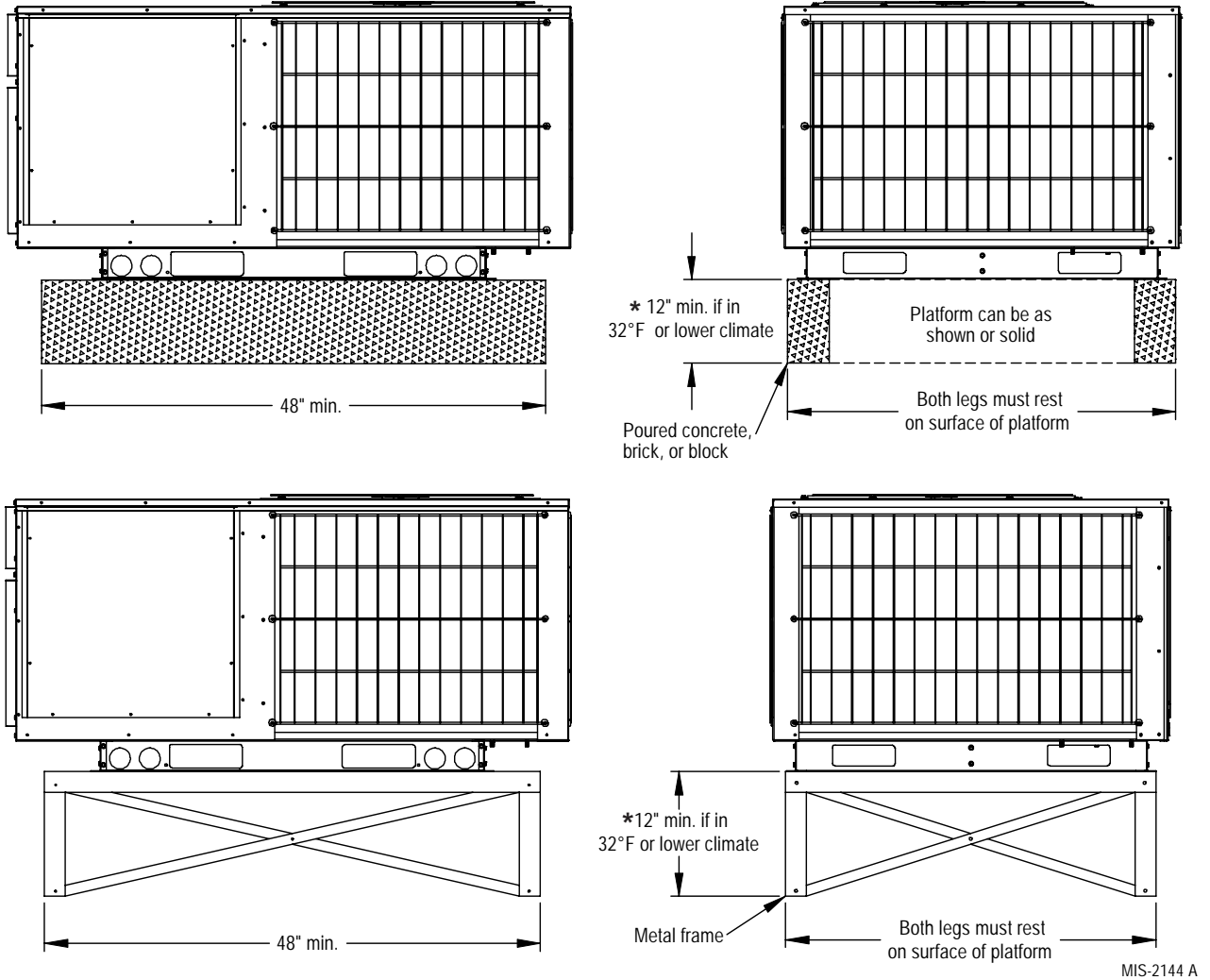


**FIGURE 3  
AIRFLOW AND SERVICE ACCESS CLEARANCES**



**NOTE:** P60R/P72R Unit shown.  
Reverse for P60L/P72L Models.

**FIGURE 4  
ELEVATED MOUNTING PLATFORM**



MIS-2144 A

\* AS REQUIRED

5. **OTHER INSTALLATIONS** – Many other installations are possible with the packaged air conditioner. No matter what the installation, always consider the following facts:

- A. Insure that the discharge air is not obstructed in any way so as to cause operation difficulties.
- B. The indoor coil drain pan is equipped with a coupling that must be piped through a condensate drain trap to a suitable drain.
- C. Always mount the unit in such a position that it may be easily reached for servicing and maintenance.
- D. Insure that the unit is clear so that proper air flow over the outdoor coil will be maintained.

If this unit is operated in cooling below a 55° outdoor ambient temperature, the installation of low ambient controls (CMA-28) to unit is required.

### CONDENSATE DRAIN TRAP

It is very important to provide a trap in the condensate drain line to allow a positive liquid seal in the line and assure correct drainage from the coil condensate pan.

Install condensate drain trap shown in Figure 8. Use drain connection size or larger. Do not operate unit without trap. Unit must be level or slightly inclined toward drain. With a trap installed on a unit located in an unconditioned area, water in the trap may freeze. It is recommended that the trap material be of a type that will allow for expansion of water when it freezes.

### AIR FILTERS

Air filters for the return air side of the system are not provided as part of these models, and must be field supplied and installed as part of the final installation.

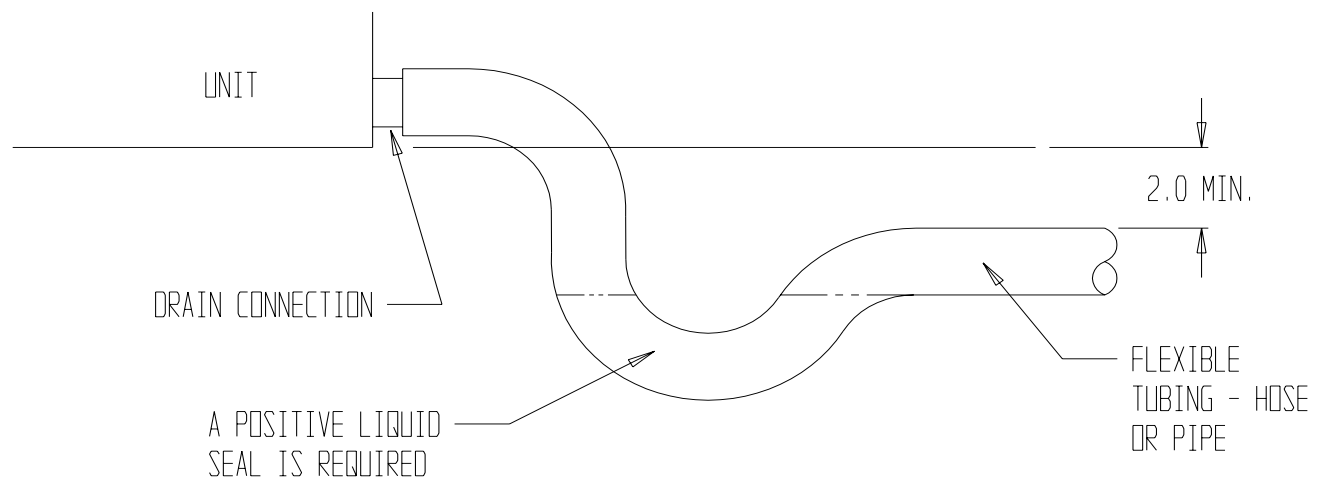
Prior thought should be given to return air location and placement of the air filter(s). The air filter(s) must be of adequate size and readily accessible to the operator of the equipment. Filters must be adequate in size and properly maintained for proper operation. If this is not done, excessive energy use, poor performance, and multiple service problems will result. *It is impossible to oversize air filters.* Generous sizing will result in cleaner air and coils as well as lower operating costs and extend the time between required changes. Table 5 shows minimum filter areas and recommended filter sizes. Actual filter sizes can vary with the installation due to single or multiple returns utilizing a filter/grille arrangement or being placed immediately ahead of the indoor coil face in the return air duct.

**TABLE 5  
FILTER REQUIREMENTS & SIZES**

Model No.	Minimum Filter Free Area	Minimum Recommended Size
P60R/LV1 P72R/LV1	473 Square Inches (3.3 Square Feet)	(2) 16 x 20 x 1

*NOTE: If roof hood accessory is to be used, information on air filters may be found under that heading in this manual. Air filters are supplied as part of that package.*

**FIGURE 5  
CONDENSATE DRAIN TRAP**



MIS-136

## WIRING – MAIN POWER

These units are rated for 60/50 Hz operation as follows.

**NOTE:** This system must be controlled only by the Bard 8403-064 Digital Thermostat/Controller that is supplied with the unit. See below for Wiring and Pages 17-18 for Operating Sequences.

Electrical Code	Volts Hz Phase	Operating Voltage Range
-R	230/208-60-1 220/200-50-1	197 - 253 180 - 242
-S	230/208-60-3 220/200-50-3	197 - 253 180 - 242
-T	460-60-3 400-50-3	414 - 506 360 - 440

Refer to the unit rating plate for wire sizing information and maximum fuse or “HACR” type circuit breaker size. Each outdoor unit is marked with a “Minimum Circuit Ampacity”. This means that the field wiring used must be sized to carry that amount of current. Depending on the installed KW of electric heat, there may be two field power circuits required. If this is the case, the unit serial plate will so indicate. All models are suitable only for connection with copper wire. Each unit and/or wiring diagram will be marked “Use Copper Conductors Only”. These instructions **must be** adhered to. Refer to the National Electrical Code (NEC) for complete current carrying capacity data on the various insulation grades of wiring material. All wiring must conform to NEC and all local codes.

The electrical data lists fuse and wire sizes (75° C copper) for all models including the most commonly used heater sizes. Also shown are the number of field power circuits required for the various models with heaters.

The unit rating plate lists a “Maximum Time Delay Fuse” or “HACR” type circuit breaker that is to be used with the equipment. The correct size must be used for proper circuit protection and also to assure that there will be no nuisance tripping due to the momentary high starting current of the compressor motor.

The disconnect access door on this unit may be locked to prevent unauthorized access to the disconnect. To convert for the locking capability, bend the tab located in the bottom left-hand corner of the disconnect opening under the disconnect access panel straight out. This tab will now line up with the slot in the door. When shut, a padlock may be placed through the hole in the tab preventing entry.

See “Start Up” section for important information on three phase scroll compressor start ups.

See Table 4 for Electrical Specifications.

## WIRING – LOW VOLTAGE WIRING

230/208V, 1 phase and 3 phase equipment have dual primary voltage transformers. All equipment leaves the factory wired on 240V tap. For 208V operation,

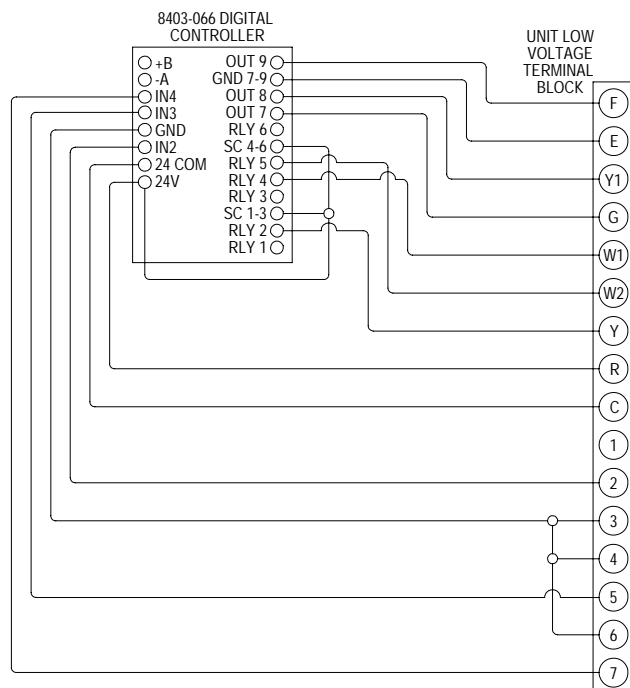
reconnect from 240V to 208V tap. The acceptable operating voltage range for the 240 and 208V taps are:

TAP	RANGE
240	253 – 216
208	220 – 187

**NOTE:** The voltage should be measured at the field power connection point in the unit and while the unit is operating at full load (maximum amperage operating condition).

## DIGITAL THERMOSTAT/CONTROLLER

Terminal	Function	Type	Form
+B	MSTP + (not used)	Communications	
-A	MSTP - (not used)	Communications	
IN4	Outdoor Temperature Sensor	Input	10K OHM Type 3
IN3	Pressure Transducer	Input	0-5 VDC, 0-700 PSIG
GND	Sensor Grounds	Input	
IN2	Lockout Alarm	Input	Relay Closure
24 COM	24VAC Com	Power	
24V	24VAC	Power	
OUT 9	Fan Motor Control	Analog Output	0-10VDC
GND7-9	Control Ground	Analog Output	
OUT 8	Unloader Solenoid Control	Analog Output	0 or 5VDC PWM
OUT 7	Blower Motor Control	Analog Output	0-10VDC
RLY 4	Heater Contactor #1	Relay Output	Relay
SC 4-6	24VAC to Relay Outputs 4-6	Power	
RLY 5	Heater Contactor #2	Relay Output	Relay
RLY 6	(not used)		
RLY 3	(not used)		
SC1-3	24VAC to Relay Outputs 1-3	Power	
RLY 2	Compressor Contactor	Relay Output	Relay
RLY 1	(not used)		



MIS-2852 C

## THESE UNITS REQUIRE R-410A REFRIGERANT AND POLYOL ESTER OIL.

### GENERAL:

1. Use separate service equipment to avoid cross contamination of oil and refrigerants.
2. Use recovery equipment rated for R-410A refrigerant.
3. Use manifold gauges rated for R-410A (800 psi/250 psi low).
4. R-410A is a binary blend of HFC-32 and HFC-125.
5. R-410A is nearly azeotropic - similar to R-22 and R-12. Although nearly azeotropic, charge with liquid refrigerant.
6. R-410A operates at 40-70% higher pressure than R-22, and systems designed for R-22 cannot withstand this higher pressure.
7. R-410A has an ozone depletion potential of zero, but must be reclaimed due to its global warming potential.
8. R-410A compressors use polyolester oil.
9. Polyol Ester oil is hygroscopic; it will rapidly absorb moisture and strongly hold this moisture in the oil.
10. A liquid line dryer must be used - even a deep vacuum will not separate moisture from the oil.
11. Limit atmospheric exposure to 15 minutes.
12. If compressor removal is necessary, always plug compressor immediately after removal. Purge with small amount of nitrogen when inserting plugs.

### TOPPING OFF SYSTEM CHARGE

If a leak has occurred in the system, Bard Manufacturing recommends reclaiming, evacuating (see criteria above), and charging to the nameplate charge. If done correctly, topping off the system charge can be done without problems.

With R-410A, there are no significant changes in the refrigerant composition during multiple leaks and recharges. R-410A refrigerant is close to being an azeotropic blend (it behaves like a pure compound or single component refrigerant). The remaining refrigerant charge, in the system, may be used after leaks have occurred and then “top-off” the charge by utilizing the charging charts on the inner control panel cover as a guideline.

*REMEMBER:* When adding R-410A refrigerant, it must come out of the charging cylinder/tank as a liquid to avoid any fractionation, and to insure optimal system performance. Refer to instructions for the cylinder that is being utilized for proper method of liquid extraction.



## WARNING

***Failure to conform to these practices could lead to damage, injury or death.***

### SAFETY PRACTICES:

1. Never mix R-410A with other refrigerants.
2. Use gloves and safety glasses, Polyol Ester oils can be irritating to the skin, and liquid refrigerant will freeze the skin.
3. Never use air and R-410A to leak check; the mixture may become flammable.
4. Do not inhale R-410A – the vapor attacks the nervous system, creating dizziness, loss of coordination and slurred speech. Cardiac irregularities, unconsciousness and ultimate death can result from breathing this concentration.
5. Do not burn R-410A. This decomposition produces hazardous vapors. Evacuate the area if exposed.
6. Use only cylinders rated DOT4BA/4BW 400.
7. Never fill cylinders over 80% of total capacity.
8. Store cylinders in a cool area, out of direct sunlight.
9. Never heat cylinders above 125°F.
10. Never trap liquid R-410A in manifold sets, gauge lines or cylinders. R-410A expands significantly at warmer temperatures. Once a cylinder or line is full of liquid, any further rise in temperature will cause it to burst.

# START UP (Continued)

---

## IMPORTANT INSTALLER NOTE

For improved start up performance wash the indoor coil with a dish washing detergent.

## HIGH PRESSURE SWITCH

All P\*\*R/LV wall mounted air conditioner series models are supplied with a remote reset for the high and low pressure switch. If tripped, this pressure switch may be reset by turning the thermostat off then back on again.

## THREE PHASE SCROLL COMPRESSOR START UP INFORMATION

Scroll compressors, like several other types of compressors, will only compress in one rotational direction. Direction of rotation is not an issue with single phase compressors since they will always start and run in the proper direction.

However, three phase compressors will rotate in either direction depending upon phasing of the power. Since there is a 50-50 chance of connecting power in such a way as to cause rotation in the reverse direction, verification of proper rotation must be made.

Verification of proper rotation direction is made by observing that suction pressure drops and discharge pressure rises when the compressor is energized. Reverse rotation also results in an elevated sound level over that with correct rotation, as well as substantially reduced current draw compared to tabulated values.

Verification of *proper rotation* must be made at the time the equipment is put into service. If improper rotation is corrected at this time, there will be no negative impact on the durability of the compressor. However, reverse operation for over one hour may have a negative impact on the bearing due to oil pump out.

*NOTE: If compressor is allowed to run in reverse rotation for several minutes, the compressor's internal protector will trip.*

All three phase compressors are wired identically internally. As a result, once the correct phasing is determined for a specific system or installation, connecting properly phased power leads to the same Fusite terminal should maintain proper rotation direction.

The direction of rotation of the compressor may be changed by reversing any two line connections to the unit.

## PHASE MONITOR

All units with three phase scroll compressors are equipped with a 3 phase 60/50 Hz line monitor to prevent compressor damage due to phase reversal. No changes required for 60 or 50 Hz operation.

The phase monitor in this unit is equipped with two LEDs. If the Y signal is present at the phase monitor and phases are correct the green LED will light.

If phases are reversed, the red fault LED will be lit and compressor operation is inhibited.

If a fault condition occurs, reverse two of the supply leads to the unit. ***Do not reverse any of the unit factory wires as damage may occur.***

## SERVICE HINTS

1. Caution owner/operator to maintain clean air filters at all times. Also, not to needlessly close off supply and return air registers. This reduces airflow through the system, which shortens equipment service life as well as increasing operating costs.
2. Check all power fuses or circuit breakers to be sure they are the correct rating.
3. Periodic cleaning of the outdoor coil to permit full and unrestricted airflow circulation is essential.

## DIGITAL CONTROLLER

The P60R/LV1 through P72R/LV1 variable capacity air conditioners utilize dedicated controllers and components to optimize this unit for cooling operation from -40 degrees F up to 131 degrees F (-40 degrees C to +55 degrees C). These units are dual rated for 200-240V or 400-460V operation on both 50 and 60 Hz. Please read the following sequence of operation before attempting any troubleshooting or repair. Troubleshooting & repair procedures will be outlined below & later in this Manual.

These models use a digital compressor and variable speed indoor and outdoor motors. The motors and compressor must be replaced with the exact same component to maintain the above stated temperature and voltage ranges of operation. The units are controlled by a Bard digital thermostat/controller, Bard part number 8403-066. This thermostat/controller contains proprietary programming and must be replaced with the exact same component to ensure proper operation.

See Controller Quick Start Manual 2100-559 and Controller Advanced Programming Manual 2100-560 for complete details.



## SEQUENCE OF OPERATION

### MODES OF OPERATION

#### **Cool Only Mode:**

- Compressor will modulate from 100% down to 20%.
- Compressor will cycle off if thermostat/controller set-point is reached.

#### **Heat Only Mode:**

- Electric heat Stage 1 operates at 1<sup>st</sup>-stage heating set-point.
- Electric heat Stage 2 (if equipped) operates on 2<sup>nd</sup> stage (-2F below heating set-point).

#### **Auto Mode:**

- Cooling or heating automatically selected based on building temperature vs. thermostat/controller set-points and operates as described above.

#### **CCVC (Continuous Compressor Variable Capacity):**

- Compressor will modulate from 100% down to 20%.
- Compressor will not cycle off if thermostat/controller set-point is reached, and would stay running at the 20% minimum capacity.
- If space temperature drops -2F below cooling set-point electric heat Stage 1 will then cycle to maintain that condition.
- If Stage 2 electric heat is installed, and if required, will cycle at -4F below cooling set-point to maintain that condition.
- If CCVC is terminated the controller will revert to Cool or Auto operation.
- CCVC would be an Operating Mode for all applications where continuous run of the compressor is a requirement.

#### **CCFC (Continuous Compressor Fixed Capacity):**

- The compressor is turned ON and locked ON as long as the thermostat/controller is in Test Mode 2.
- When in CCFC the compressor does not modulate but will be locked ON at 100% capacity.
- If space temperature drops -2F below cooling set-point electric heat Stage 1 will then cycle to maintain that condition.
- If Stage 2 electric heat is installed, and if required, will cycle at -4F below cooling set-point to maintain that condition.
- If CCFC is terminated the controller will revert to Cool or Auto operation.
- CCFC would not be considered an Operating Mode and should only be used for system testing as required.

#### **Indoor Blower Operation**

The indoor blower speed will modulate with the compressor operation from 50% to 100% of operation. Once compressor operation is at 50% or below, percent airflow will be at 50% and no further reduction of airflow will occur. Modulation is accomplished by modulating a 0-10 volt signal from OUT 7 to the indoor blower control board which then sends a PWM signal to the indoor blower motor.

An additional option to maintain airflow at 100% is also available. This selection is done at the thermostat/controller under Fan Modes. Default is No for “Always 100%” setting. Change to Yes to disable indoor blower modulation as described above.

2 LED’s are located on the Blower Control Board. The Red LED will light anytime 24V is applied to the board and it is connected to the ECM motor. The Green LED will flash a series of short and long flashes depending on the output from the digital thermostat/controller.

#### **Outdoor Fan Motor Operation**

The outdoor fan motor speed is varied in response to outdoor air temperature and pressure. The fan motor will cycle on and off with the compressor when not in CCVC or CCFC. At all times above 122 degrees OAT, the outdoor fan, OUT 9, will be energized at high speed. From 122 degrees to 55 degrees the outdoor fan, OUT 9, will be set at normal outdoor airflow. Below 55 degrees the outdoor fan will modulate to maintain a 300 psi head pressure. This will act as a low ambient fan cycling control. The output may go to zero output to maintain the 300 PSI. The outdoor ECM motor will be programmed with a minimum RPM allowed to protect the bearing system. Any signal that is less than the percent torque required to maintain the minimum RPM will cause the motor to shut off. Once head pressure rises the motor will restart.

These functions are regulated by the digital thermostat/controller with input from the pressure transducer and output signal to the Fan Control Board.

2 LED’s are located on the outdoor Fan Control Board. The Red LED is not active and does not light under any condition. The Green LED will flash a series of short and long flashes depending on the output from the digital thermostat/controller.

#### **Capacity Modulation and High Head Pressure Control**

The pressure transducer monitors the high side pressure providing input to the digital thermostat/controller. It is powered using a 5Vdc power supply with a digital relay signaling the compressor unloader solenoid as required. When the ECU head pressure exceeds 615 PSI based on outdoor and indoor ambient conditions the compressor will automatically start to reduce capacity to stay on-line keeping the pressure at or below 575 PSI. The thermostat/controller display alternates between OD temperature and discharge pressure. When compressor capacity is being reduced due to high pressure conditions it will also indicate “High Head Pressure Control” mode on the display. A separate 650 PSI high pressure cutout switch is also employed as additional safety device. See Compressor Control Module on following page for more details.

## COOLING SEQUENCE

### Compressor Operation

The cooling capacity of the PV Series is controlled by loading or unloading the compressor. On a call for cooling, the unloader solenoid is energized for one second to ensure pressure equalization in the compressor. The compressor contactor, RLY 2, is then energized and the compressor will start. A PI control loop then calculates the compressor capacity needed to reach set point and modulates the compressor. Modulation range is from 20% to 100% capacity. Modulation is accomplished by a pulse width modulated signal from OUT 8 which energizes the solid state relay (SSR) and energizes or de-energizes the unloader solenoid. The required compressor capacity is calculated every 15 seconds.

**20% load** means 0 VDC for 3.0 seconds and 5 VDC for 12.0 seconds from OUT 8.

**30% load** means 0 VDC for 4.5 seconds and 5 VDC for 10.5 seconds from OUT 8.

**40% load** means 0 VDC for 6.0 seconds and 5 VDC for 9.0 seconds from OUT 8.

**50% load** means 0 VDC for 7.5 seconds and 5 VDC for 7.5 seconds from OUT 8.

**60% load** means 0 VDC for 9.0 seconds and 5 VDC for 6.0 seconds from OUT 8.

**70% load** means 0 VDC for 10.5 seconds and 5 VDC for 4.5 seconds from OUT 8.

**80% load** means 0 VDC for 12.0 seconds and 5 VDC for 3.0 seconds from OUT 8.

**90% load** means 0 VDC for 13.5 seconds and 5 VDC for 1.5 seconds from OUT 8.

**100% load** means 0 VDC for 15 seconds and 5 VDC for 0.0 seconds from OUT 8.

### Outdoor Temperature Sensor

A sensor probe projects out the bottom of the ECU control box into the outdoor section, and this provides input for the outdoor fan sequences below 55F and above 115F described under Outdoor Fan Motor Operation.

### Discharge Temperature Sensor

This sensor is mounted on the compressor discharge line and protects the compressor against overheating. It opens at 250F and closes at 200F.

## HEATING SEQUENCE

On a call for heating, if the space temperature falls 1°F below setpoint, the first stage of heating, RLY 4, will cycle ON. If the space temperature falls 3°F below setpoint, the second stage of heating, RLY 5, will cycle ON. Indoor Blower airflow is maintained at the Rated unit airflow at all times during heating.

Control Device	Normal	Abnormal
Indoor Motor Blower Control Board	Red LED lit, Green LED flashes long and short flashes when Fan is called for, 2-10Vdc from Signal to Common. Jumper is on P.	No Red LED, and no Green flashes when 2-10Vdc is present from Signal to Common. Jumper is on P.
Outdoor Motor Fan Control Board	Red LED not lit. Green long and short flashes when 2-10Vdc present from Signal to Common on board. Jumper is on P.	Red LED lit, and no Green flashes when 2-10Vdc is present from Signal to Common. Jumper is on P.
5Vdc Power Supply	Red LED lit when 24Vac present. 5Vdc present at solid Red and solid Black wires. Both jumpers on Half. 3A 250V fuse.	Red LED not lit. 5Vdc not present at solid Red and solid Black wires. Both jumpers on Half. Check 3A fuse.

## LEAD/LAG SEQUENCE

The digital controllers can be used for dual units used in a redundant application by using the scheduling function as follows:

1. The controllers should be mounted side by side so that they are in the same temperature zone.
2. The time setting on both controllers need to be synchronized to the same time of day. NOTE: there is a 72-hour time retention if power is removed. If power off-time exceeds 72 hours, the time clock in each device must be reset to match. The exact time is not important as long as both controllers are set the same unless it is critical to control the time of day when the units swap operating positions.
3. Set one controller #1 to be Occupied for a 12-hour period and Unoccupied for the other 12-hour period. Set controller #2 so that it is exactly the opposite. Unoccupied for the 12-hour period when #1 is Occupied and Occupied when #1 is Unoccupied.
4. Set Occupied cooling setpoint the same for each controller, and Unoccupied the same for each. 4°F difference is suggested.
5. Set controllers to "Auto" mode of operation.

### Example:

1. Both Unit #1 and #2 have Occupied setpoint of 74°F and Unoccupied setpoint of 78°F
2. Unit #1 set for Occupied from 1:00 a.m. to 1:00 p.m. & Unoccupied from 1:00 p.m. to 1:00 a.m.
3. Unit #2 set for Unoccupied from 1:00 a.m. to 1:00 p.m. & Occupied from 1:00 p.m. to 1:00 a.m.
4. Every 12 hours the units will swap position as being the lead unit, and the lag unit is available for back up operation at the higher temperature should the situation ever arise.

## COMPRESSOR CONTROL MODULE

The compressor control module is standard on all models covered by this manual. The compressor control module is an anti-short cycle/lockout timer with high and low pressure switch monitoring and alarm relay output.

### Adjustable Delay On Make And Break Timer

On initial power up or anytime power is interrupted to the unit, the *delay on make* period begins, which will be 2 minutes plus 10% of the *delay on break* setting. When the delay on make is complete and the high pressure switch and low pressure switch is closed, the compressor contactor is energized. Upon shutdown, the delay on break timer starts and prevents restart until the delay on break and delay on make periods have expired.

During routine operation of the unit with no power interruptions, the compressor will operate on demand with no delay.

### High Pressure Switch and Lockout Sequence

If the high pressure switch opens, the compressor contactor will de-energize immediately. The lockout timer will go into a *soft lockout* and stay in soft lockout until the high pressure switch closes and the delay on break time has expired. If the high pressure switch opens again in this same operating cycle, the unit will go into *manual lockout* condition and the alarm relay circuit will energize. Recycling the wall thermostat resets the manual lockout.

### Low Pressure Switch, Bypass, and Lockout Sequence

If the low pressure switch opens for more than 120 seconds, the compressor contactor will de-energize and go into a soft lockout. Regardless the state of the low pressure switch, the contactor will reenergize after the delay on make time delay has expired. If the low pressure switch remains open, or opens again for longer than 120 seconds, the unit will go into manual lockout condition and the alarm relay circuit will energize. Recycling the wall thermostat resets the manual lockout.

## Alarm Relay Output

Alarm terminal is output connection for applications where alarm relay is employed. This terminal is powered whenever the compressor is locked out due to HPC or LPC sequences as described.

*NOTE: Both high and low pressure switch controls are inherently automatic reset devices. The high pressure switch and low pressure switch cut out and cut in settings are fixed by specific air conditioner unit model. The lockout features, both soft and manual, are a function of the Compressor Control Module.*

## ADJUSTMENTS

### Adjustable Delay on Make and Delay on Break Timer

The potentiometer is used to select Delay on Break time from 30 seconds to 5 minutes. Delay on Make (DOM) timing on power-up and after power interruptions is equal to 2 minutes plus 10% of Delay on Break (DOB) setting:

0.5 minute (30 seconds)	DOB = 123 second	DOM
1.0 minute (60 seconds)	DOB = 126 second	DOM
2.0 minute (120 seconds)	DOB = 132 second	DOM
3.0 minute (180 seconds)	DOB = 138 second	DOM
4.0 minute (240 seconds)	DOB = 144 second	DOM
5.0 minute (300 seconds)	DOB = 150 second	DOM

During routine operation of the unit with no power interruptions the compressor will operate on demand with no delay.

### Typical Settings for Dual Unit Installation:

Unit 1: DOB set at 2 minutes, and DOM is 132 seconds

Unit 2: DOB set at 4 minutes, and DOM is 144 seconds

# SERVICE AND TROUBLESHOOTING

## SERVICE HINTS

1. Caution homeowner to maintain clean air filters at all times. Also, not to needlessly close off supply and return air registers. This reduces airflow through the system which shortens equipment service life as well as increasing operating costs.
2. Check all power fuses or circuit breakers to be sure that they are the correct rating.
3. Periodic cleaning of the outdoor coil to permit full and unrestricted airflow circulation is essential.

## PRESSURE SERVICE PORTS

High and low pressure service ports are installed on all units so that the system operating pressures can be observed. A pressure table can be found later in this manual covering all models on cooling cycle. It is imperative to match the correct pressure table to the unit by model number.

# R-410A

## REFRIGERANT CHARGE

This unit was charged at the factory with the quantity of refrigerant listed on the serial plate. AHRI capacity and efficiency ratings were determined by testing with this refrigerant charge quantity.

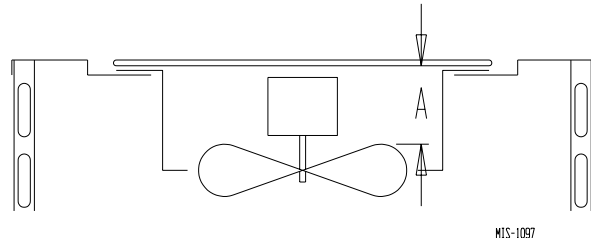
The following pressure tables show nominal pressures for the units. Since many installation specific situations can affect the pressure readings, this information should only be used by certified technicians as a guide for evaluating proper system performance. They shall not be used to adjust charge. If charge is in doubt, reclaim, evacuate and recharge the unit to the serial plate charge.

## FAN BLADE SETTINGS

Shown in Figure 6 are the correct fan blade setting dimensions for proper air delivery across the outdoor coil.

Any service work requiring removal or adjustment in the fan and/or motor area will require that the dimensions below be checked and blade adjusted in or out on the motor shaft accordingly.

**FIGURE 6  
FAN BLADE SETTING**



**TABLE 6  
FAN BLADE SETTING DIMENSIONS**

Model	Dimension "A"
P60R/LV1	3¼"
P72R/LV1	

**TABLE 7  
COOLING PRESSURE TABLE**

Air Temperature Entering Outdoor Coil °F (°C)

Model	Return Air Temperature	Pressure	75°	80°	85°	90°	95°	100°	105°	110°	115°
<b>P60RV1 P60LV1</b>	75° DB 62° WB	Low Side High Side	122 344	122 362	122 381	123 405	124 430	125 458	127 490	129 525	131 562
	80° DB 67° WB	Low Side High Side	130 353	130 371	131 391	132 415	133 441	134 470	136 503	138 538	140 576
	85° DB 72° WB	Low Side High Side	135 365	135 384	136 405	137 430	138 456	139 486	141 521	143 557	145 596
<b>P72RV1 P72LV1</b>	75° DB 62° WB	Low Side High Side	108 351	111 371	114 392	117 416	120 443	122 471	125 501	128 534	130 569
	80° DB 67° WB	Low Side High Side	116 360	119 380	122 402	125 427	128 454	131 483	134 514	137 548	139 584
	85° DB 72° WB	Low Side High Side	120 373	123 393	126 416	129 442	132 470	136 500	139 532	142 567	144 604

LOW SIDE PRESSURE +/- 4 PSIG  
HIGH SIDE PRESSURE +/- 10 PSIG

Tables based upon rated CFM (airflow) across the evaporator coil.

If incorrect charge suspected (more than ±4 psig suction, ±10 psig liquid), it is recommended refrigerant charge be reclaimed, system evacuated and charged to serial plate quantity.

## SUCTION AND DISCHARGE TUBE BRAZING

Compliant Scroll compressors have copper plated steel suction and discharge tubes. These tubes are far more rugged and less prone to leaks than copper tubes used on other compressors. Due to different thermal properties of steel and copper, brazing procedures may have to be changed from those commonly used.

- To disconnect: heat joint Areas 2 and 3 slowly and uniformly until braze material softens and the tube can be pulled out of suction fitting. (See Figure 7.)
- To connect:
  - Recommended brazing materials: silfos with minimum 5% silver or silver braze material with flux.

- Reinsert tube into fitting.
- Heat tube uniformly in Area 1 moving slowly to Area 2. When joint reaches brazing temperature, apply brazing material. (See Figure 7.)
- Heat joint uniformly around the circumference to flow braze material completely around the joint.
- Slowly move torch into Area 3 to draw braze material into joint. (See Figure 7.)
- **Do not** overheat joint.

**FIGURE 7  
BRAZING DIAGRAM**

