INSTALLATION INSTRUCTIONS

2-STAGE HEAT PUMPS LOW VOLTAGE CONTROL CIRCUIT WIRING

MODELS

T**S

T**S*D

C**H



Climate Control Solutions

Bard Manufacturing Company, Inc.
Bryan, Ohio 43506

Since 1914...Moving ahead just as planned.

Manual : 2100-554E
Supersedes: 2100-554D
File: Volume III Tab 16
Date: 11-05-13

Contents

Installation Instructions

Wiring – Low Voltage Wiring	3
Operating Voltage Range.....	3
Low Voltage Connection	3

Figures

Figure 1 Basic HP w/Opt. Elec. Heat	5
Figure 2 Opt. MFAD, CRV & ERV Vent. Pkg. w/ Programmable T-Stat	6
Figure 3 Heat Pump w/Opt. Economizer	7
Figure 4 HP w/Dehumidification Sequence & No Vent Pkg. Using T-Stat Comb	8
Figure 5 HP w/Dehumidification Sequence & Opt. MFAD, CRV, & ERV Vent Pkg. Using Elec. T-Stat with Combination Temp. & Humidity Control	9
Figure 6 Dehum. HP w/Opt. Economizer	10
Figure 7 2-Stage HP w/Opt. Elec. Heat w/ ECONWM* Style Economizer	11
Figure 8 2-Stage HP w/Dehum. & Opt. Elec. Heat w/ECONWM* Style Economizer	12
Figure 9 2-Stage HP w/CHCRV-5 or CRVMWH-3 Vent Opt. Pkg. w/Prog. T-Stat with Optional On/Off CO2 Controller	13
Figure 10 2-Stage HP w/CHCRV-5 or CRVMWH-3 Vent Opt. Pkg. w/Prog. T-Stat with Optional Modulating CO2 Controller	14

Tables

Table 1 Diagram to Use w/Unit & Vents.....	3
Table 2 Operating Voltage Range.....	3
Table 3 Wall Thermostat	3
Table 4 Humidity Controls.....	4
Table 5 CO ₂ Controller	4
Table 6 Thermostat Wire Size.....	4

**TABLE 1
DIAGRAM TO USE WITH UNIT AND VENTS**

MODEL SERIES	No Vents	ERV MFAD CRV	CRVMWH-3 CHCRV-5	Economizer "E" Vent Option	T, W, S ECONWMT
VENT CODE	X	R, M, V, P	C	E	T, W, S
T**S / C**H	1	2	9 & 10	3	7
T**S*D	4	5	9 & 10	6	8

WIRING – LOW VOLTAGE WIRING

230/208V, 1 phase and 3 phase equipment dual primary voltage transformers. All equipment leaves the factory wired on 240V tap. For 208V operation, reconnect from 240V to 208V tap. The acceptable operating voltage range for the 240V and 208V taps are:

**TABLE 2
OPERATING VOLTAGE RANGE**

TAP	RANGE
240V	253 - 216
208V	220 - 187

NOTE: The voltage should be measured at the field power connection point in the unit and while the unit is operating at full load (maximum amperage operating condition).

An 18 gauge copper, color-coded thermostat cable is recommended. The connection points are shown in this Manual. See Table above.

Low Voltage Connection

These units use a grounded 24-volt AC low voltage circuit.

The “R” terminal is the *hot* terminal and the “C” terminal is *grounded*.

“G” terminal is the *fan input*.

“Y” terminal is the *compressor input* Stage 1.

“B” terminal is the *reversing valve input*. The reversing valve must be energized for heating mode.

“R” terminal is the *24 VAC hot*.

“C” terminal is the *24 VAC grounded*.

“Y1” terminal is the *compressor input* Stage 2.

“L” terminal is *compressor lockout output*. This terminal is activated on a high or low pressure trip by the electronic heat pump control. This is a 24 VAC output.

“W2” terminal is *second stage heat* (if equipped).

“O1” terminal is the *ventilation input*. This terminal energizes any factory installed ventilation option.

“E” terminal is the *emergency heat input*. This terminal energizes the emergency heat relay.

“W3” terminal is the *dehumidification input*. This terminal energizes compressor, blower and three-way valve. ①

**LOW VOLTAGE CONNECTIONS
FOR DDC CONTROL**

Fan Only	Energize G
Cooling Mode 1 st Stage	Energize Y, G
Cooling Mode 2 nd Stage	Energize Y, Y1, G
Heat Pump Heating 1 st Stage	Energize Y, G, B
Heat Pump Heating 2 nd Stage	Energize Y, Y1, B, G
3 rd Stage Heating w/Heat Pump (if employed)	Energize G, W2, Y, B, Y1
Ventilation	Energize G, O1
Emergency Heat	Energize B, W2, E, G
Dehumidification ①	Energize W3

① Applies only to Models equipped for dehumidification sequence.

**TABLE 3
WALL THERMOSTAT**

Part Number	Predominate Features
8403-060 (1120-445)	3 stage Cool; 3 stage Heat Programmable/Non-Programmable Electronic HP or Conventional Auto or Manual changeover Dehumidification Output

**TABLE 4
HUMIDITY CONTROLS**

Part Number	Predominate Features
8403-038 (H600A1014)	SPDT switching, pilot duty 50VA @ 24V Humidity range 20-80% RH
8403-047 (H200-10-21-10)	Electronic dehumidistat SPST closes-on-rise Humidity range 10-90% with adjustable stops

**TABLE 5
CO2 CONTROLLER**

Part Number	Predominate Features
8403-067	Normally Open SPST relay closes-on-rise 24V dual wave length sensor. Default setting 950ppm, adjustable to 0-2000ppm Default off setting 1000ppm, adjustable to 0-200 ppm can be calibrated

**TABLE 6
THERMOSTAT WIRE SIZE**

TRANSFORMER VA	FLA	Wire Gauge	Maximum Distance In Feet
55	2.3	20 gauge	45
		18 gauge	60
		16 gauge	100
		14 gauge	160
		12 gauge	250

FIGURE 1
BASIC HEAT PUMP WITH OPTIONAL ELECTRIC HEAT
NO ECONOMIZER or VENTILATION PACKAGES

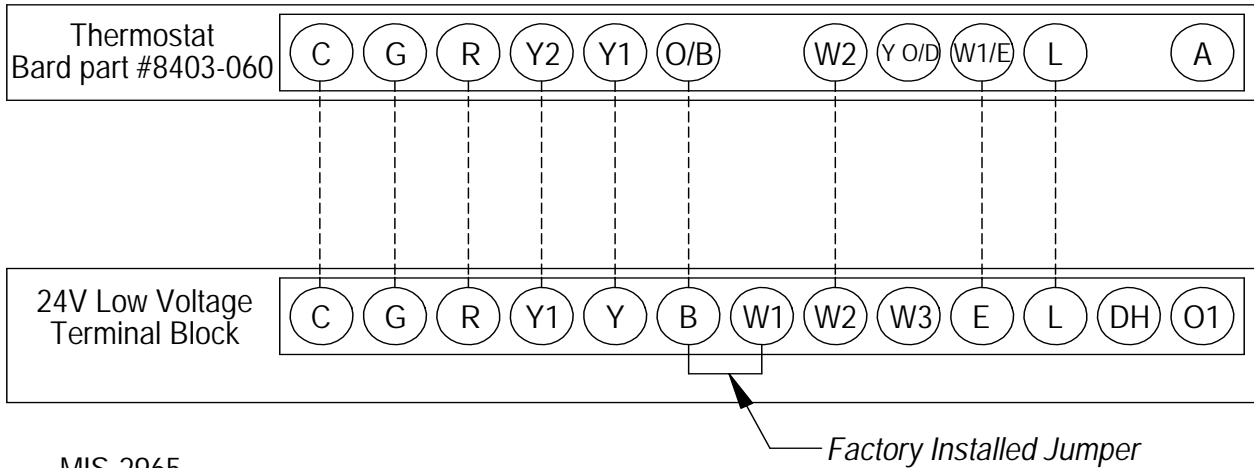
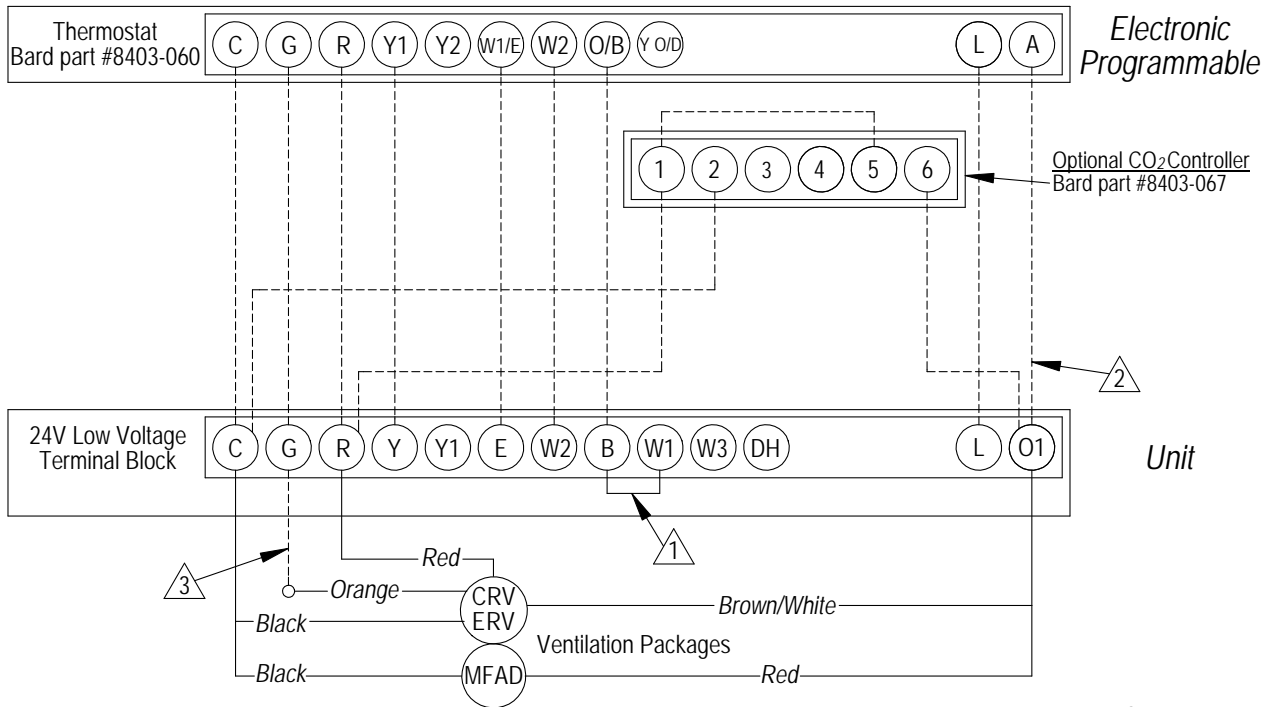

FIGURE 2
HEAT PUMP WITH OPTIONAL MFAD, CRV & ERV
VENTILATION PACKAGING WITH PROGRAMMABLE THERMOSTAT

Low Voltage Wiring Diagram



- 1 Factory Jumper Installed
- 2 Do not connect "A" from tstat #8403-060 if optional CO₂ controller is used.
- 3 Connect orange wire to "G" only if optional CO₂ controller is used.

MIS-2966 B

**FIGURE 3
HEAT PUMP WITH OPTIONAL ECONOMIZER**

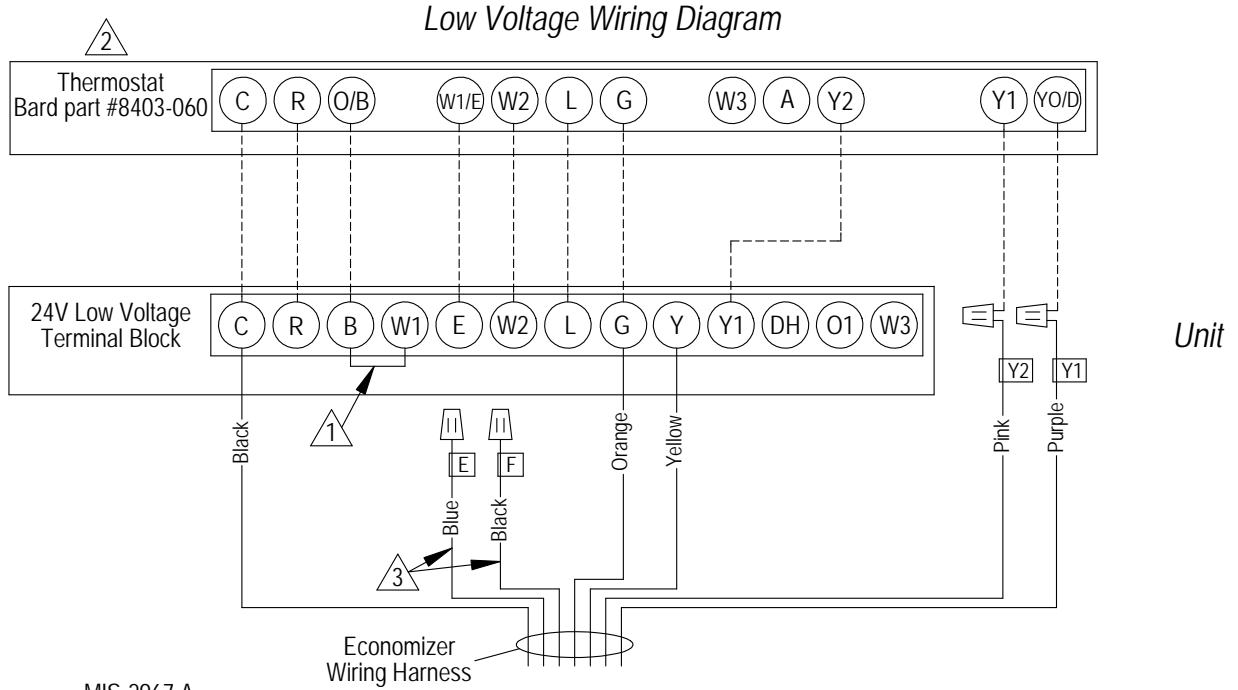

- ① Factory Jumper Installed.
- ② Must be configured for economizer with YO/D output to be active as first stage cooling.
- ③ These wires are used in special control applications only.

FIGURE 4
HEAT PUMP WITH DEHUMIDIFICATION SEQUENCE AND NO VENTILATION PACKAGE
USING THERMOSTAT #8403-060 COMBINATION TEMPERATURE & HUMIDITY CONTROLLER

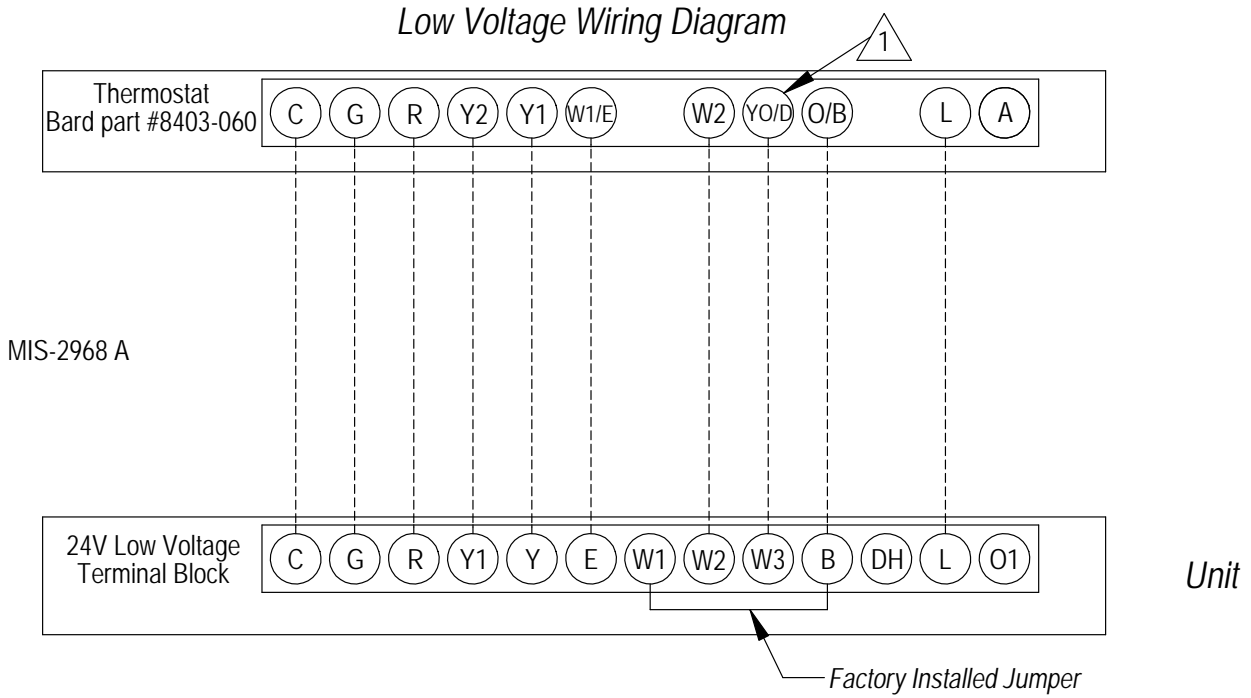

△ 1 *Must be configured for "no economizer" to make YO/D output active for humidity control.*

FIGURE 5
HEAT PUMP WITH DEHUMIDIFICATION SEQUENCE & OPTIONAL MFAD, CRV & ERV VENTILATION
PACKAGING USING ELECTRONIC THERMOSTAT WITH COMBINATION TEMPERATURE &
HUMIDITY CONTROL WITH OPTIONAL CO₂ CONTROLLER

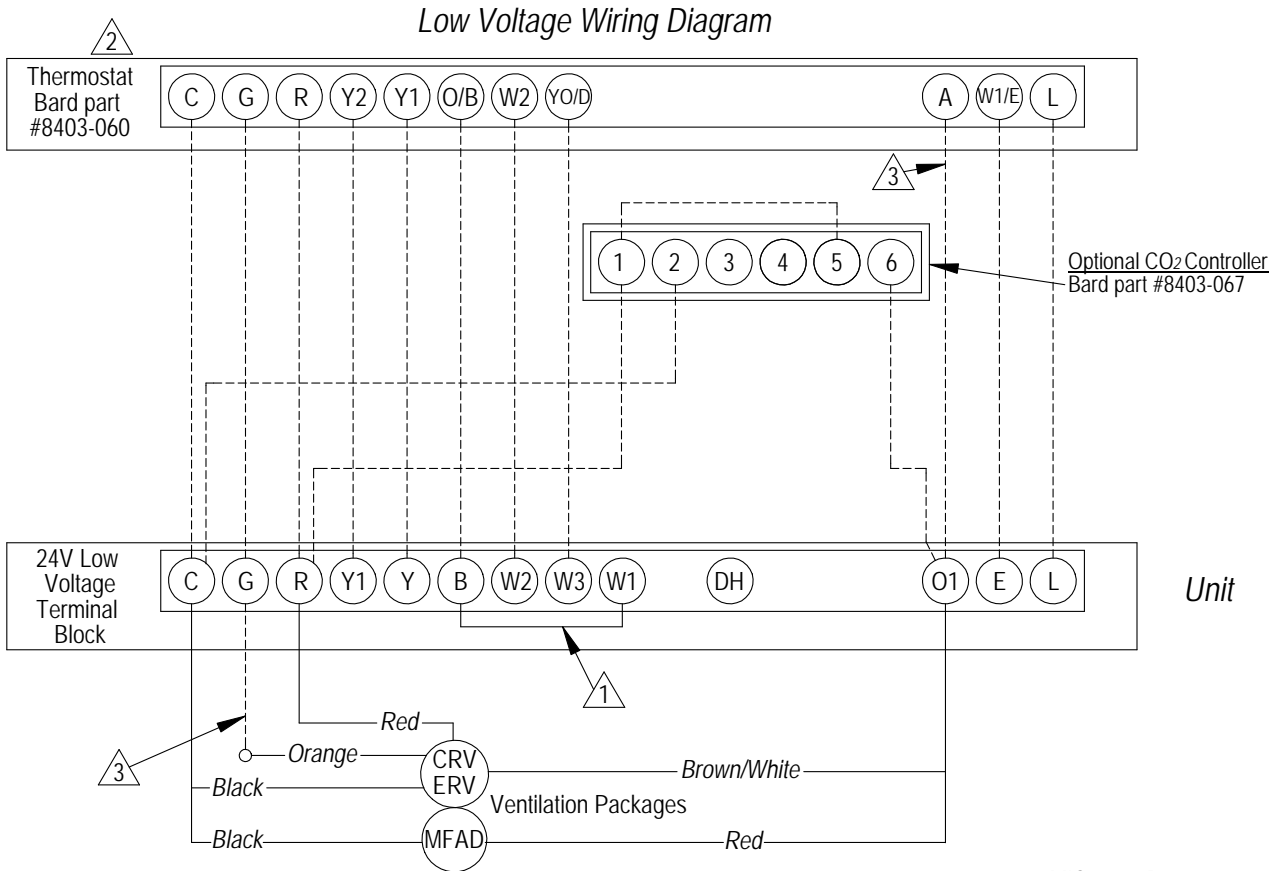

- ⚠️ 1 Factory Jumper Installed
- ⚠️ 2 Must be configured for "no economizer" to make YO/D output active for humidity control.
- ⚠️ 3 Do not connect "A" from thermostat if optional CO₂ controller is used. Connect orange wire to "G" only when optional CO₂ controller is used.

MIS-2969 B

FIGURE 6
DEHUMIDIFICATION HEAT PUMP WITH OPTIONAL ECONOMIZER

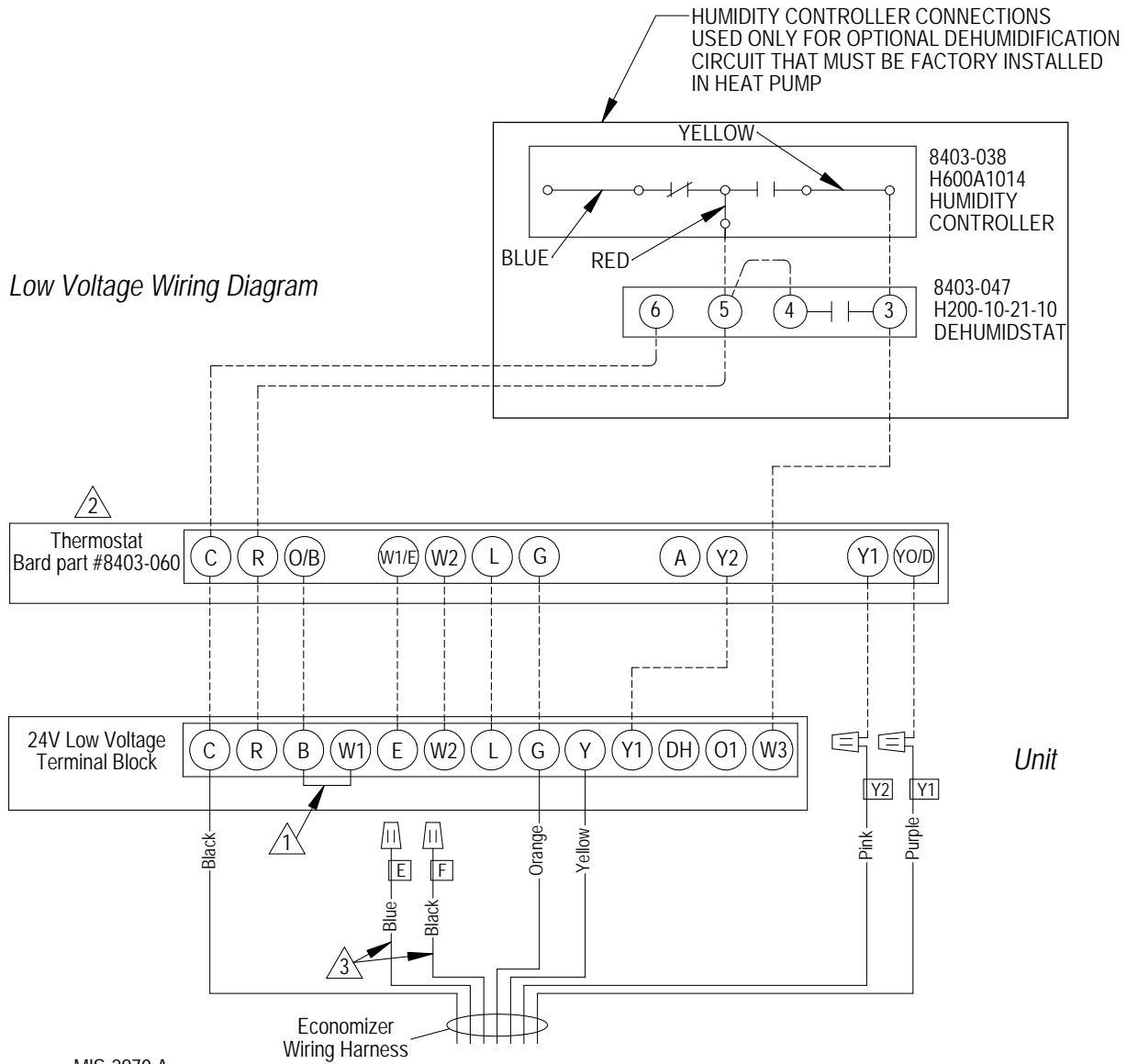

- ① Factory Jumper Installed.
- ② Must be configured for economizer with YO/D output to be active as first stage cooling.
- ③ These wires are used in special control applications only.

FIGURE 7
2-STAGE HEAT PUMP WITH OPTIONAL ELECTRIC HEAT
WITH ECONWM* STYLE ECONOMIZER

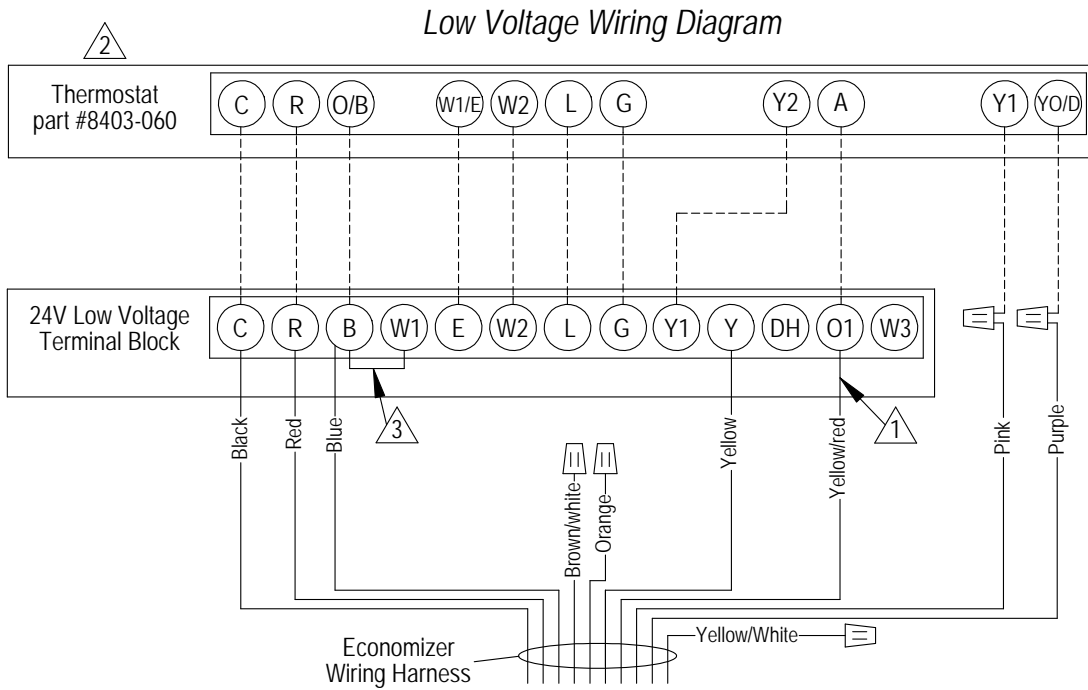

△1 Must be energized to enable minimum position. NOTE: Economizer Control Default Setting is 10V (100%). Depending upon application may require setting to lower value.

△2 Must be configured for heat pump and economizer to enable YO/D output to be active as 1st-stage cooling

△3 Factory Jumper Installed.

MIS-2982 B

FIGURE 8
2-STAGE HEAT PUMP WITH DEHUMIDIFICATION & OPTIONAL ELECTRIC HEAT
WITH ECONWM* STYLE ECONOMIZER

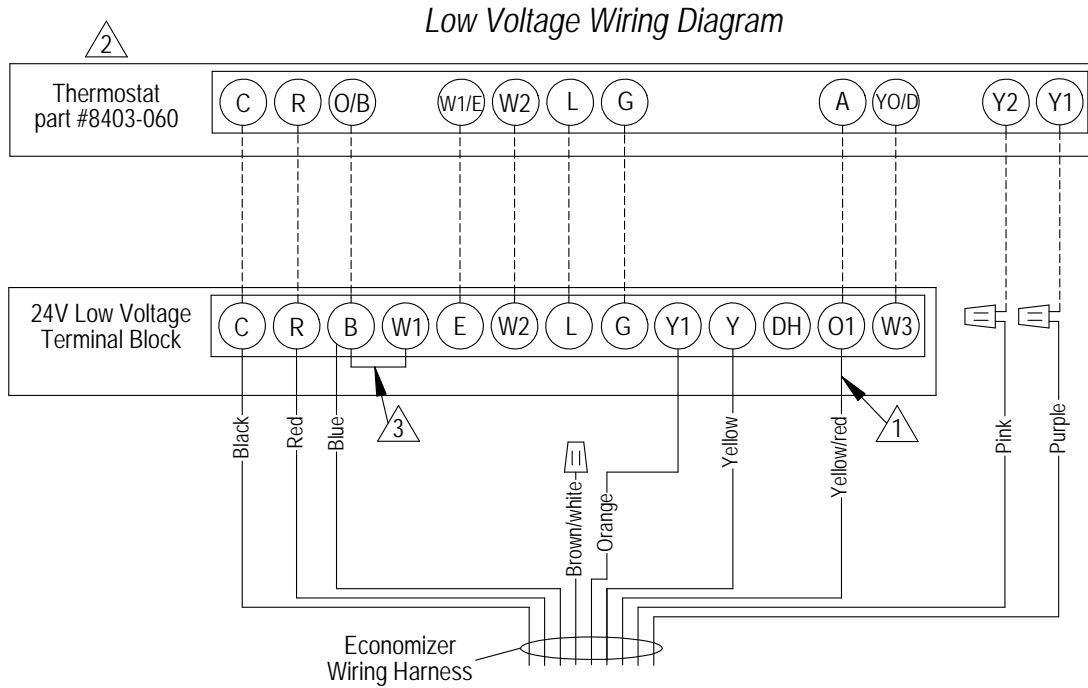

- △1 Must be energized to enable minimum position. NOTE: Economizer Control Default Setting is 10V (100%). Depending upon application may require setting to lower value.
- △2 Must be configured for heat pump to enable YO/D output to be active dehumidification output
- △3 Factory Jumper Installed.

MIS-2999

FIGURE 9
2-STAGE HEAT PUMP WITH CHCRV-5 OR CRVMWH-3
VENT OPTION PACKAGE WITH PROGRAMMABLE THERMOSTAT
WITH OPTIONAL ON/OFF CO₂ CONTROLLER

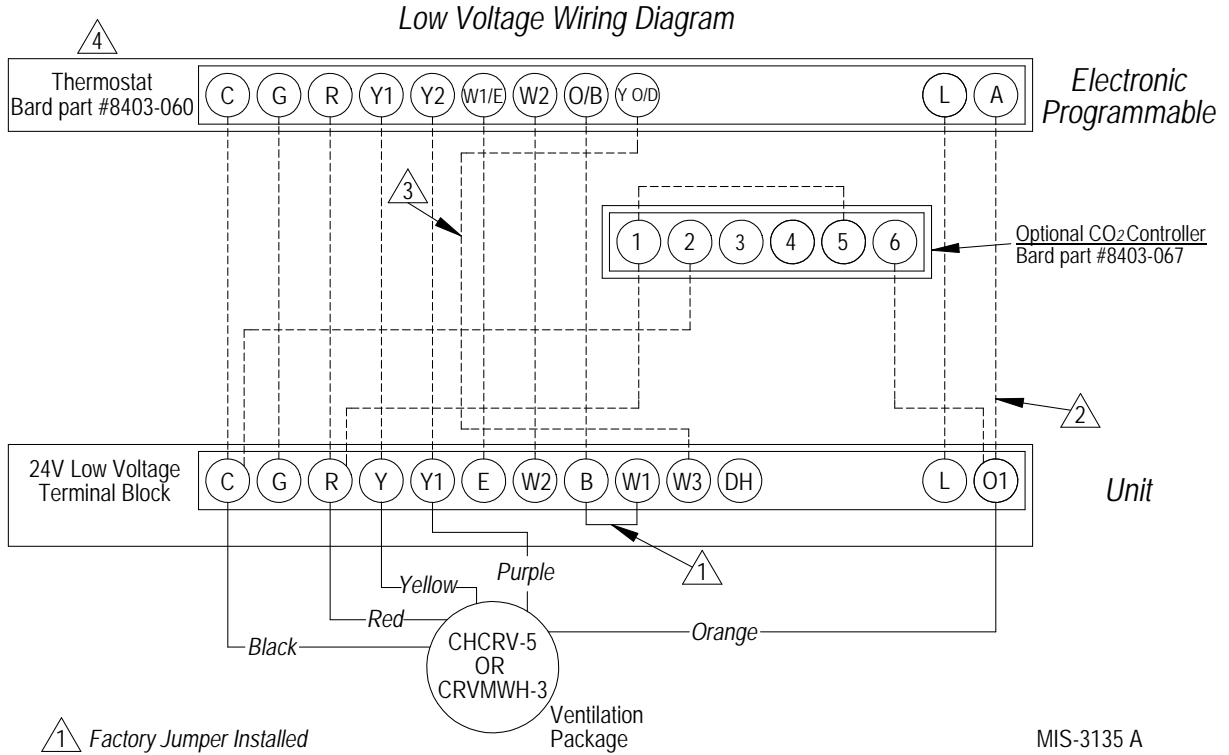

- 1 Factory Jumper Installed
- 2 Do not connect "A" from tstat #8403-060 if optional CO₂ controller is used.
- 3 Wire only needed for dehumidification units
- 4 Must be configured to programmable and fan set to programmed for the "A" output to function during scheduled occupied periods

MIS-3135 A

FIGURE 10
2-STAGE HEAT PUMP WITH CHCRV-5 OR CRVMWH-3
VENT OPTION PACKAGE WITH PROGRAMMABLE THERMOSTAT
WITH OPTIONAL MODULATING CO2 CONTROLLER

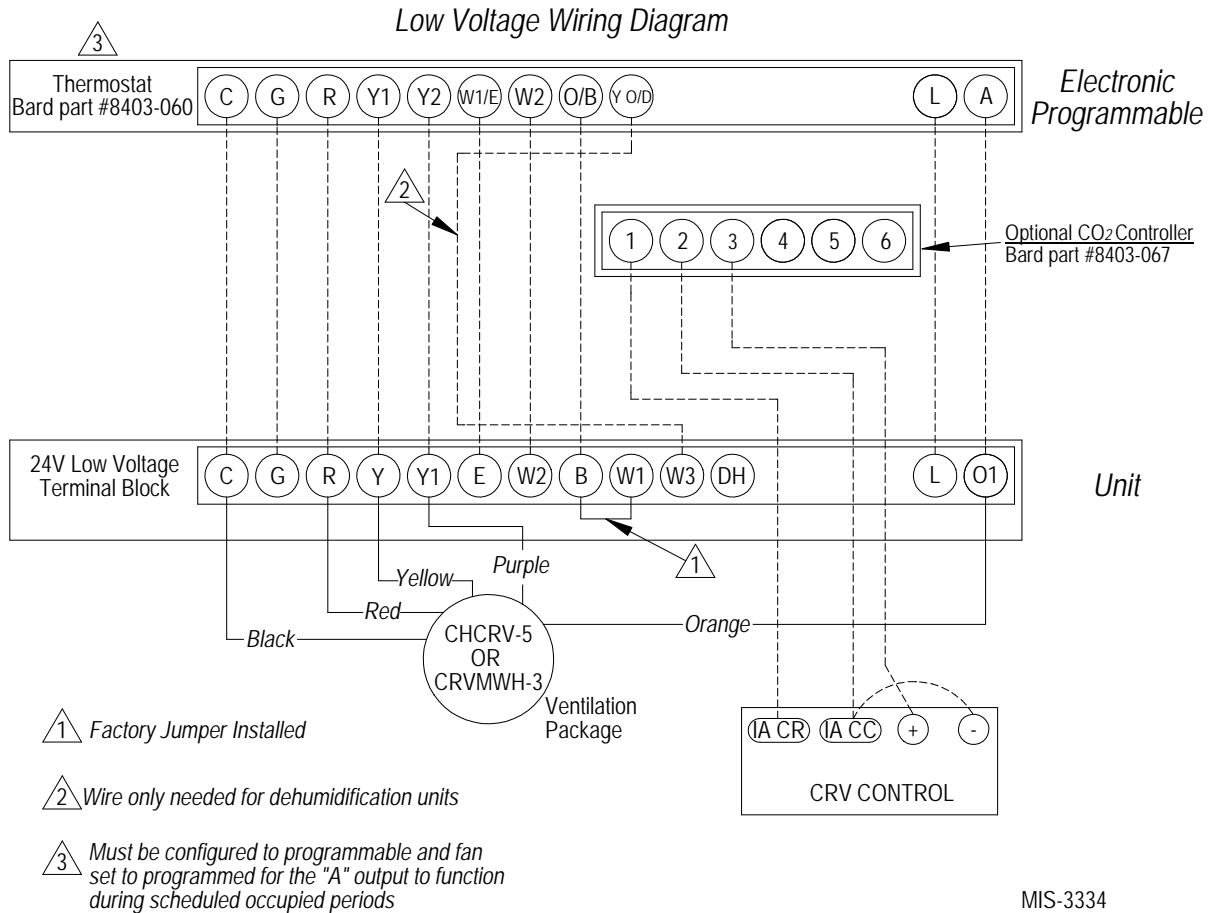

MIS-3334