

INSTALLATION INSTRUCTIONS

I-TEC WALL SLEEVE FOR 1" AND 2" LOUVERS

Models:

IWS-A IWS-B IWS-C

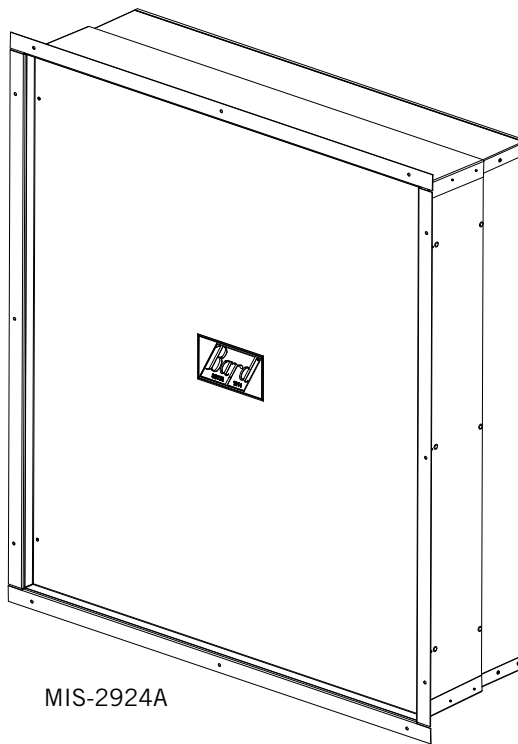

MIS-2924A



Climate Control Solutions

Bard Manufacturing Company, Inc.
Bryan, Ohio 43506
www.bardhvac.com

Manual: 2100-562F
Supersedes: 2100-562E
Date: 4-27-18

CONTENTS

Getting Other Information and Publications 3

I-TEC Wall Sleeve General Information

- Shipping Damage 4
- General 4
- Unpacking 4
- Side Angle Relocation for ILA-2 Louver..... 4

Installation

- Installation – Wood Framed Walls..... 6
- Installation – Masonry Construction Walls 7
- Attachment of Wall Sleeve to I-TEC Unit..... 8

Figures

- Figure 1 IWS-* Wall Sleeve Dimensions..... 4
- Figure 2 I-TEC and Wall Sleeve 5
- Figure 3 Side Angle Relocation 5
- Figure 4 Wood Framed Installation..... 6
- Figure 5 Application of Sealant to Flanges..... 7
- Figure 6 Masonry Construction Installation 7
- Figure 7 Typical Installation 8
- Figure 8 Attachment of Wall Sleeve 9

Getting Other Information and Publications

These publications can help you install the air conditioner or heat pump. You can usually find these at your local library or purchase them directly from the publisher. Be sure to consult current edition of each standard.

Standard for the InstallationANSI/NFPA 90A
of Air Conditioning and Ventilating Systems

Standard for Warm Air Heating.....ANSI/NFPA 90B
and Air Conditioning Systems

I-TEC Installation Instruction Manual... Bard/2100-549
(latest revision)

FOR MORE INFORMATION, CONTACT THESE PUBLISHERS:

ACCA **Air Conditioning Contractors of America**
1712 New Hampshire Avenue, NW
Washington, DC 20009
Telephone: (202) 483-9370
Fax: (202) 234-4721

ANSI **American National Standards Institute**
11 West Street, 13th Floor
New York, NY 10036
Telephone: (212) 642-4900
Fax: (212) 302-1286

ASHRAE **American Society of Heating,
Refrigerating, and Air Conditioning
Engineers, Inc.**
1791 Tullie Circle, N.E.
Atlanta, GA 30329-2305
Telephone: (404) 636-8400
Fax: (404) 321-5478

BARD **Bard Manufacturing Company, Inc.**
1914 Randolph Drive
Bryan, OH 43506
Telephone: (419) 636-1194
Fax: (419) 636-2640

I-TEC WALL SLEEVE GENERAL INFORMATION

SHIPPING DAMAGE

Upon receipt of equipment, the carton should be checked for external signs of shipping damage. If damage is found, the receiving party must contact the last carrier immediately, preferably in writing, requesting inspection by the carrier's agent.

GENERAL

The IWS-* Series Wall Sleeve is designed for use with the I-TEC Series heat pump. The wall sleeve assembly consists of a large intake sleeve and a smaller exhaust sleeve. Both sleeves are telescoping to adjust for different wall depths. See Figures 1 and 2.

WALL SLEEVE MODEL NO.	WALL THICKNESS	STANDARD LOUVER DEPTH
IWS-A	5.5" – 8"	1"
IWS-B	8" – 13.5"	1"
IWS-C	13" – 23.5"	1"

These instructions explain the recommended method to install the wall sleeve. The equipment covered in this manual is to be installed by trained service and installation technicians.

These instructions and any instructions packaged with any separate equipment required to make the entire air conditioning system should be carefully read before beginning the installation.

While intended as a general recommended guide, these instructions do not supersede any national and/or local codes in any way. Authorities having jurisdiction should be consulted before the installation is made.

UNPACKING

1. The smaller exhaust sleeve is attached to the weatherization plate with two (2) screws for shipping. Remove these screws (throw away) and set the exhaust sleeve assembly aside.
2. Remove the inner telescoping sleeve (with the rubber gasket) from larger inlet sleeve and set it aside.
3. Remove inlet sleeve, with weatherization plate attached, from the carton and turn over.
4. Remove and save the four (4) screws attaching the security plate.

SIDE ANGLE RELOCATION FOR ILA-2 LOUVER

The IWS-* wall sleeve is designed for use with both 1" and 2" louver depths. As shipped, the sleeve is ready for 1" louver installation. Refer to Figure 3 for angle installation instructions for 2" louver depth.

FIGURE 1
IWS-* Wall Sleeve Dimensions

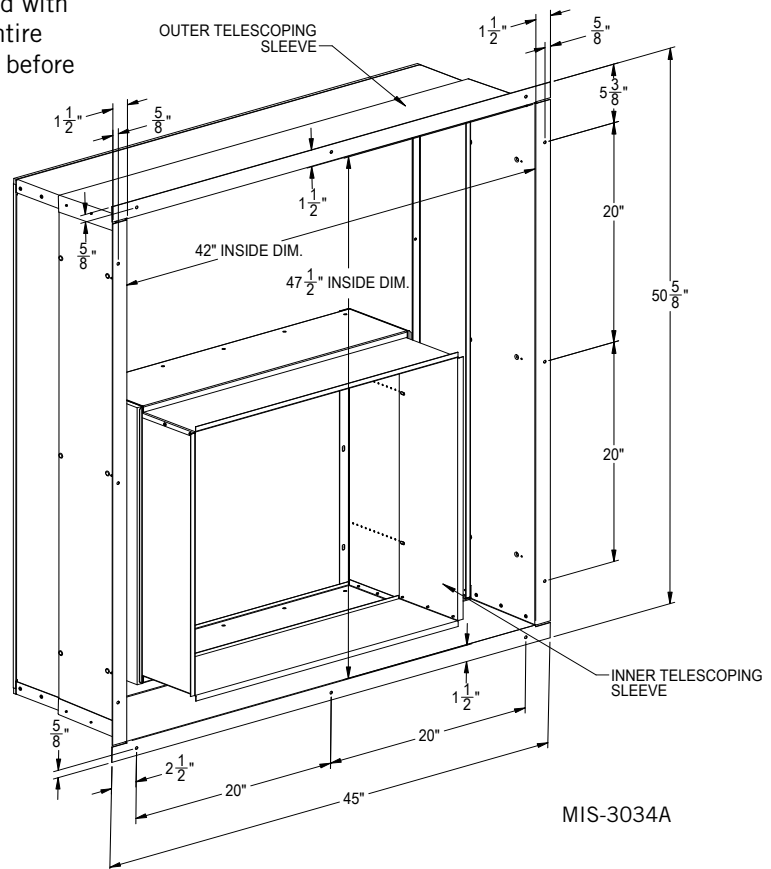
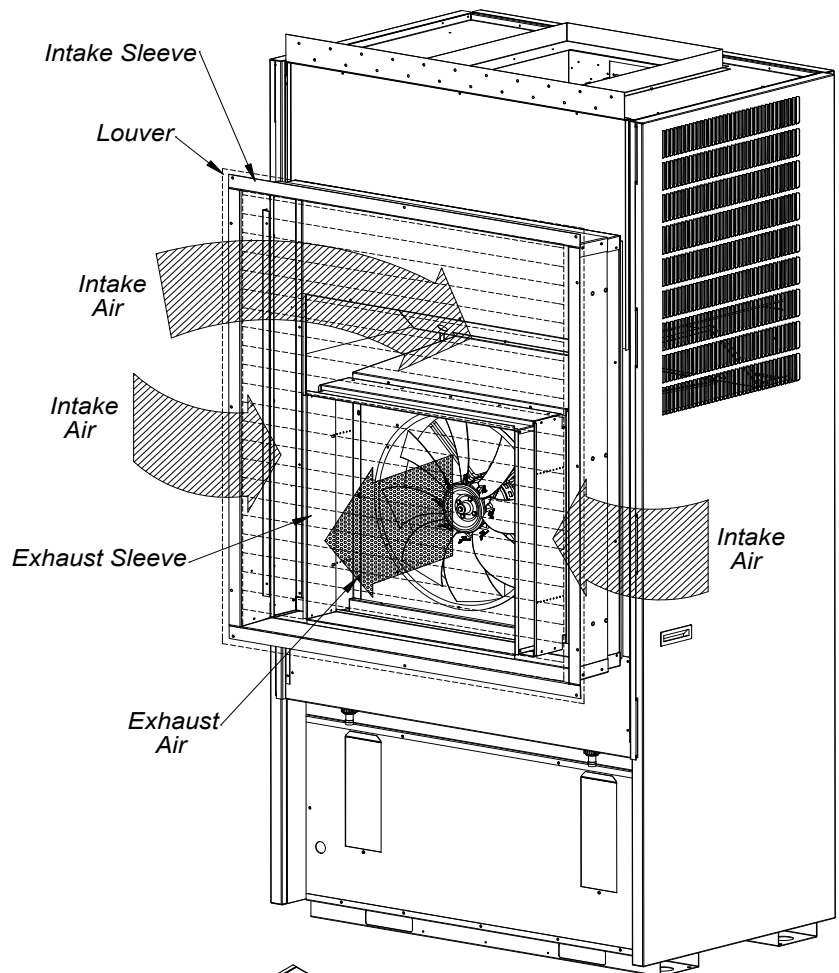
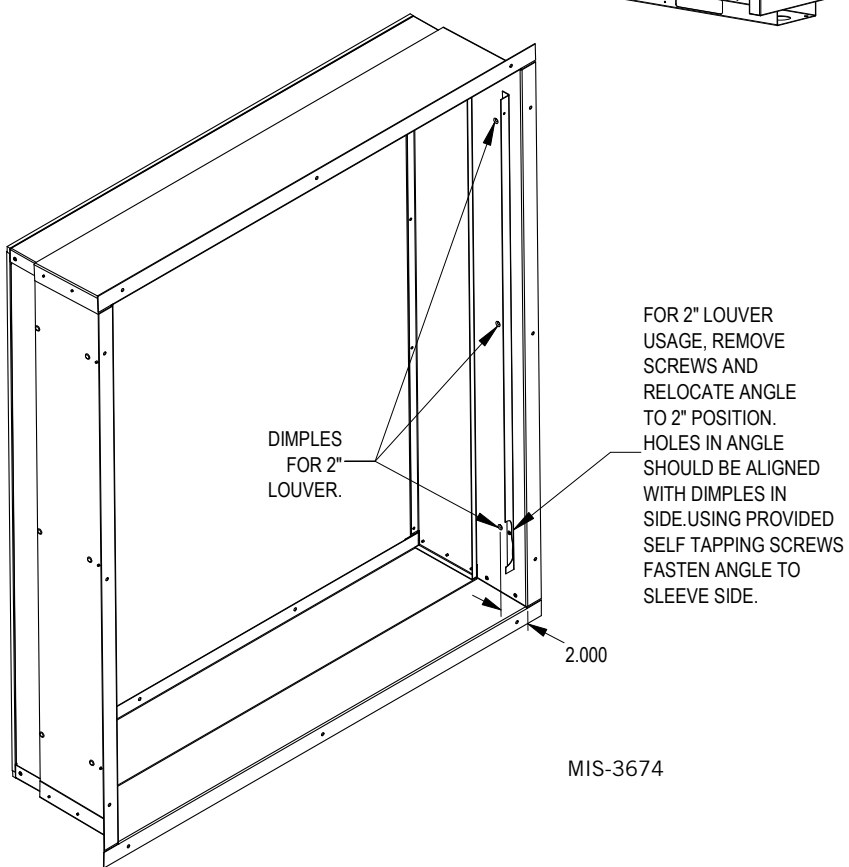

FIGURE 2
I-TEC and Wall Sleeve



MIS-2931 B

FIGURE 3
Side Angle Relocation



MIS-3674

INSTALLATION – WOOD FRAMED WALLS

For wood frame construction walls, the minimum dimensions of the opening must be 48" tall by 42³/₄" inches wide. A 2 x 6 header will be required for the opening. The sides of the opening must have trimmer studs to support the header, and to provide a structural member on which to fasten the sleeve. See Figure 4. All of the dimensions are referenced from the finished floor height. If a riser platform accessory is used, adjust dimensions accordingly.

Once the opening is framed, the sheeting can be installed, the sheeting material must not extend into the opening.

The intake sleeve should be test fit into the opening to make sure of the dimensions. The sleeve must be inserted into the opening from the outside of the building. The bottom of the sleeve must be level from side to side, and the sleeve must be square in the opening. A slope is built into the bottom of the sleeve from the inside to the outside. This will allow any water that gets into the sleeve to drain out. Once the test fit is completed, the sleeve must be removed from the opening, and two 1/4" beads of sealant must be applied to the mounting flanges of the sleeve. See Figure 5.

The sleeve is then reinserted into the prepared opening from the outside of the building. All of the mounting flanges must contact the exterior wall. Check to see that there is enough sealant to make this joint watertight. Additional sealant must be applied

as necessary. The sleeve must be centered in the opening, and the bottom of the sleeve must be checked to make certain that it is level from side to side. The bottom flange should be secured to the wall by using two (2) field-supplied wood screws through the holes in the bottom mounting flange of the sleeve. The sleeve must be checked to make sure that it is square in the opening. Once the sleeve is square, the side and top mounting flanges of the sleeve must be secured to the wall with ten (10) field-supplied wood screws through the holes in the flanges.

The inner portion of the intake sleeve must be inserted from the inside of the building. While holding the flanged side of the sleeve, slide it into the outer sleeve and insert far enough so it projects approximately 1/2" from either the smooth wall surface or from the sill. Final adjustment must be done from the outside.

On the inside of the building, the gaps between the sleeve and the rough wall opening must be filled with insulation.

NOTE: If foamed insulation is used, the final location of the inner sleeve must be determined since the foam insulation could lock the inner sleeve into an incorrect location causing either an air leak between sleeve and back of unit or preventing the unit from going as tight to the wall or sill as desired. This must be done before the unit is placed and before the inner portion of the intake sleeve is secured with screws to the outer sleeve. Insulating this space will prevent infiltration of any unwanted outside air. See Figure 7 on page 9.

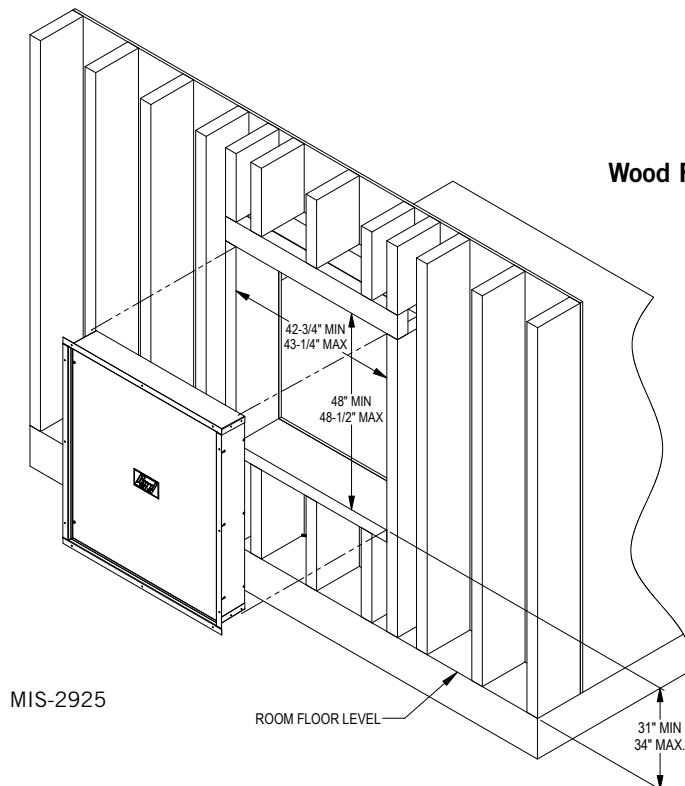

FIGURE 4
Wood Framed Installation

FIGURE 5
Application of Sealant to Flanges

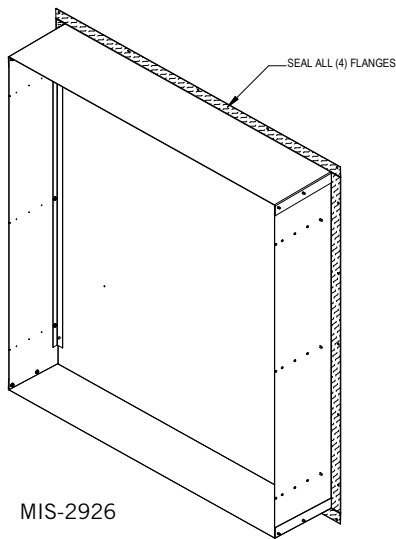
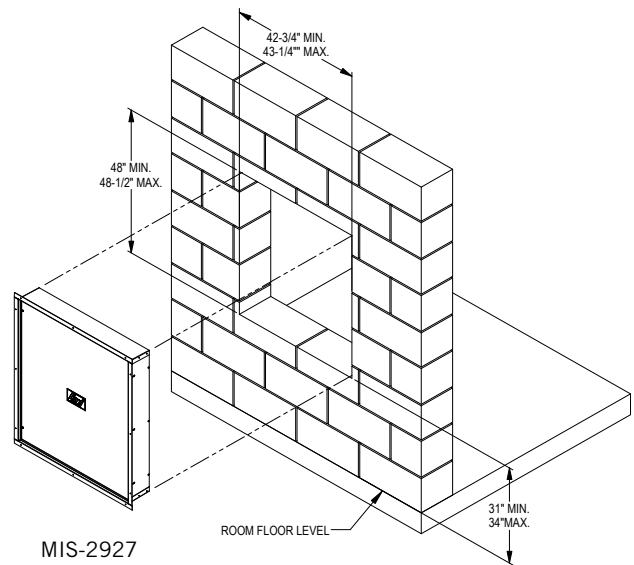

FIGURE 6
Masonry Construction Installation



If the I-TEC unit will be drained through the wall, the drain line must be installed prior to setting the unit. Information for the drain installation is provided in the main Installation Manual supplied with the unit. At this point, the following are options:

1. Install the weatherization plate, if the I-TEC unit is not ready to be installed.

NOTE: The exhaust sleeve attaches to the I-TEC unit. Store it and any remaining mounting hardware in a safe location.

2. Proceed with attachment of wall sleeve to I-TEC unit (Page 8).

INSTALLATION – MASONRY CONSTRUCTION WALLS

For masonry construction walls, the minimum dimensions for the opening will be 48" tall by 42³/₄" wide. These dimensions are measured from the finished floor height. See Figure 5. These will be the finish dimensions of the opening.

The sleeve should be test fit in the opening before final preparations are made. The sleeve will be installed into the opening from the outside of the building in. The sleeve must be centered in the opening from side to side. The mounting flanges of the sleeve must contact the outside wall all around the opening. The side and top mounting flanges must have the mounting holes drilled into the outside wall for the concrete anchors which will hold the sleeve in the wall.

The holes should be drilled through the holes in the sleeve with the sleeve level and square in the opening. A slope is built into the bottom of the sleeve from the inside to the outside. This will allow any water that gets into the sleeve to drain out. Once the test fitting has been checked out, the sleeve should be removed from the wall.

With the sleeve removed, two 1/4" beads of sealant must be applied to the flanges that contact the outside wall. See Figure 5.

The sleeve must be installed back in the wall making sure that the predrilled holes in the wall line up with the holes in the mounting flanges of the sleeve. Check to make sure that there is enough sealant between the wall and the flanges to make the joint watertight. Additional sealant must be applied as required. The sleeve must be anchored to the wall. All four mounting flanges must be fastened to the outside wall using twelve (12) field-supplied masonry screws.

The inner portion of the intake sleeve must be inserted from the inside of the building. While holding the flanged side of the sleeve, slide it into the outer sleeve and insert far enough so it projects approximately 1/2" from either the smooth wall surface or from the sill. Final adjustment must be done from the outside.

On the inside of the building, the gaps between the sleeve and the rough wall opening must be filled with insulation.

NOTE: If foamed insulation is used, the final location of the inner sleeve must be determined since the foam insulation could lock the inner sleeve into an incorrect location causing either an air leak between sleeve and back of unit or preventing the unit from going as tight to the wall or sill as desired. This must be done before the unit is placed and before the inner portion of the intake sleeve is secured with screws to the outer sleeve. Insulating this space will prevent infiltration of any unwanted outside air. See Figure 7.

If the I-TEC unit will be drained through the wall, the drain line must be installed prior to setting the unit.

Information for the drain installation is provided in the main Installation Manual supplied with the unit. At this point, the following are options:

1. Install the weatherization plate if the I-TEC unit is not ready to be installed.

NOTE: The exhaust sleeve attaches to the I-TEC unit. Store it and any remaining mounting hardware in a safe location.

2. Proceed with attachment of wall sleeve to I-TEC unit.

FIGURE 7
Typical Installation

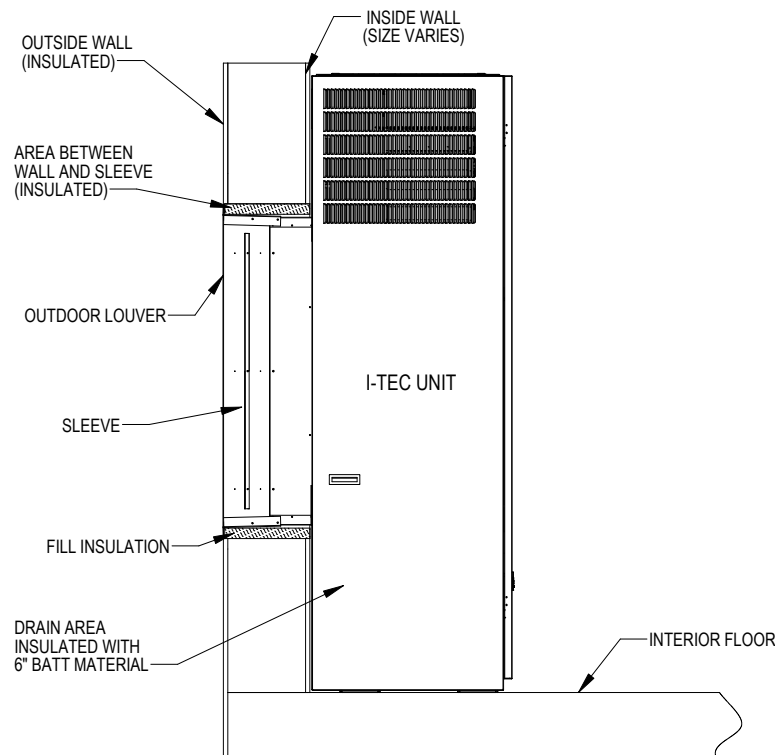

MIS-2928C

ATTACHMENT OF WALL SLEEVE TO I-TEC UNIT

Move the unit into place ensuring it is aligned side to side. Push it back until the side panels are flush with the wall, or until the sides contact the window sill—if that is the case. From the outside of the building, push the inner sleeve inward until the foam gasket contacts the unit. Attach the sleeve to the rear of the I-TEC using the twelve (12) $\frac{3}{4}$ " long self-tapping screws supplied with the sleeve (Figure 8, Ref. B).

Tie the inner and outer sleeves together with the three (3) $\frac{3}{4}$ " long self-tapping screws on each side (Figure 8,

Ref. A). Apply a bead of caulk to the entire perimeter seam between the inner and outer sleeves (Figure 8, Ref. A).

The exhaust sleeve has three (3) screw slots in each side flange. Line these up with the screw engagement holes in the fan panel. Attach using six (6) $\frac{3}{4}$ " long sheet metal screws supplied with the sleeve (Figure 8, Ref. C). Extend the sleeve out until it is flush with the louver attachment angles. Lock the sleeve in place using two (2) $\frac{1}{2}$ " long sheet metal screws on each side by shooting through the slot into a pre-punched hole (Figure 8, Ref. D). Use $1\frac{1}{2}$ " long screws supplied to attach louver to outer sleeve (See Figure 8, Ref. E).

FIGURE 8
Attachment of Wall Sleeve

Use (12) Field Supplied Concrete or Wood Screws to Secure Outer Sleeve to Structure.

IMPORTANT!
Apply liberal amount of caulk to back of flange before installing.

REF. A

Use (6) 3/4" Long Self Tapping Screws to Attach Inner Sleeve to Outer Sleeve

IMPORTANT!
Apply Caulk bead to entire perimeter seam between inner and outer sleeve.

REF. B

Use (12) 3/4" Long Self Tapping Screws to Attach Inner Sleeve to Unit Back

IMPORTANT!
Use care when inserting screws to not damage gasketing material. Doing so may compromise water seal between unit and sleeve.

Pull Inner Frame Out Until Flush With Louver Mounting Angle

REF. E

Use (4) 1-1/2" Long Screws to Attach Louver to Outer Sleeve.

NO CAULK BEHIND LOUVER

REF. C

Use (8) 3/4" Long Screws to Attach Exhaust Sleeve to Unit Fan Shroud

REF. D

Use (12) 1/2" Long Screws to Attach frame to Exhaust Sleeve

(18) 5/16" - 3/4" SELF TAPPING	REF. A AND B	
(8) 5/16" - 3/4" NON-TAPPING	REF. C	
(12) 5/16" - 1/2" NON-TAPPING	REF. D	
(4) 1-1/2" LONG SCREWS	REF. E	

MIS-3014 C