

---

# INSTALLATION INSTRUCTIONS

# DOUBLE O-RING GEO-PRIME TANK Non-Pressurized Flow Center System

Model: DORGPT-1

---



**NOTE:** This guide provides the installer with instructions specific to the Bard Double O-Ring Geo-Prime Tank (Bard Model DORGPT-1). Please refer to the specific unit installation instructions and IGSHA guidelines for additional detailed flushing, purging, and installation information.



**WARNING** This device is applicable only to non-pressurized installations.



*Climate Control Solutions*

Bard Manufacturing Company, Inc.  
Bryan, Ohio 43506  
*Since 1914 . . . Moving ahead, just as planned.*

Manual: 2100-565  
Supersedes: *NEW*  
File: Volume I, Tab 8  
Date: 02-02-12

# CONTENTS

---

<b>Getting Other Informations and Publications.....</b>	<b>3</b>	<b>Determining Fluid Level</b>	
<b>General Information</b>		General .....	10
Description .....	4	<b>Checking Loop Fluid</b>	
<b>Installation</b>		General .....	10
Overview .....	5	<b>Adding Loop Fluid</b>	
<b>Standard Procedure</b>		Notes & Caution.....	11
Description and Steps.....	6 & 7	<b>Replacing a Pump</b>	
<b>Flushing &amp; Purging</b>		Description and Steps.....	12 – 14
General .....	7 – 9	<b>Measuring Flow Rate</b>	
<b>Initial Start-Up</b>		General .....	15
General .....	9	<b>Troubleshooting</b>	
<b>Adding or Checking Fluid</b>		Troubleshooting Table.....	16
Notes .....	10		

---

## Figures

Figure 1	DORGPT-1 During System Op. ....	4
Figure 2	DORGPT-1 During Flushing/Purging .....	4
Figure 3	Dimensional Information .....	5
Figure 4	DORGPT-1 Mounted Above Flow Ctr.....	5
Figure 5	Flow Center Installed (Horiz. Shaft) .....	6
Figure 6	Flow Center w/Valve Coupling Adapter.....	6
Figure 7	Installing DORGPT-1 .....	7
Figure 8	DORGPT-1 Cap & Valve Face Covers .....	7
Figure 9	Valve Position for Flushing/Purging .....	8
Figure 10	Valve Position for System Op.....	9
Figure 11	Valve Position to Isolate Ground Loop from Flow Center & HP .....	12
Figure 12	Connections for Flushing HP Side of System w/Garden Hose .....	13
Figure 13	Connections & Valve Positions for Flushing HP Side of System w/Circulator .....	14
Figure 14	Connections & Valve Positions for Flow .... Meter Tool .....	15

## Tables

Table	Troubleshooting.....	16
-------	----------------------	----

---

## GETTING OTHER INFORMATION AND PUBLICATIONS

---

These publications can help you install the air conditioner or heat pump. You can usually find these at your local library or purchase them directly from the publisher. Be sure to consult current edition of each standard.

National Electrical Code .....ANSI/NFPA 70

Standard for the Installation.....ANSI/NFPA 90A  
of Air Conditioning and Ventilating Systems

Standard for Warm Air.....ANSI/NFPA 90B  
Heating and Air Conditioning Systems

Load Calculation for Residential .....ACCA Manual J  
Winter and Summer Air Conditioning

Duct Design for Residential.....ACCA Manual D  
Winter and Summer Air Conditioning and Equipment  
Selection

Closed-Loop/Ground Source Heat Pump .....IGSHPA  
Systems Installation Guide

Grouting Procedures for Ground-Source .....IGSHPA  
Heat Pump Systems

Soil and Rock Classification for .....IGSHPA  
the Design of Ground-Coupled Heat Pump Systems

Ground Source Installation Standards .....IGSHPA

Closed-Loop Geothermal Systems .....IGSHPA  
– Slinky Installation Guide

### FOR MORE INFORMATION, CONTACT THESE PUBLISHERS:

**ACCA**    **Air Conditioning Contractors of America**  
1712 New Hampshire Avenue  
Washington, DC 20009  
Telephone: (202) 483-9370  
Fax: (202) 234-4721

**ANSI**    **American National Standards Institute**  
11 West Street, 13th Floor  
New York, NY 10036  
Telephone: (212) 642-4900  
Fax: (212) 302-1286

**ASHRAE** **American Society of Heating Refrigerating,  
and Air Conditioning Engineers, Inc.**  
1791 Tullie Circle, N.E.  
Atlanta, GA 30329-2305  
Telephone: (404) 636-8400  
Fax: (404) 321-5478

**NFPA**    **National Fire Protection Association**  
Batterymarch Park  
P.O. Box 9101  
Quincy, MA 02269-9901  
Telephone: (800) 344-3555  
Fax: (617) 984-7057

**IGSHPA** **International Ground Source  
Heat Pump Association**  
490 Cordell South  
Stillwater, OK 74078-8018

## GENERAL DESCRIPTION

Please review the entire Installation Instructions before proceeding with the installation.

The Double O-Ring Geo-Prime Tank is an accessory that can be added to a standard flow center to create a **non-pressurized flow center system**. In addition to its applicability in a non-pressurized system, the Tank can be used to retrofit traditional pressurized systems to non-pressurized systems. The DORGPT-1 consists of a fluid reservoir, two bypass valves and an air-eliminating dip tube inside of a foam-insulated cabinet. The Tank includes a sealing cap with integrated pressure and vacuum relief to prevent the reservoir from being over-pressurized or collapsing. The Tank is mounted above the suction flange of the pump to ensure a flooded volute and to provide the necessary suction head pressure for the pump.

When the ground source heat pump system is operating, the pump circulates loop fluid through the heat pump, ground loop, and DORGPT-1. The loop fluid is directed to the bottom of the DORGPT-1's reservoir on one side of an internal baffle which allows air to separate from the fluid. Air-free loop fluid is then returned to the system. Additional details of the DORGPT-1 are provided in the figures below.

**FIGURE 1  
DORGPT-1  
DURING SYSTEM OPERATION**

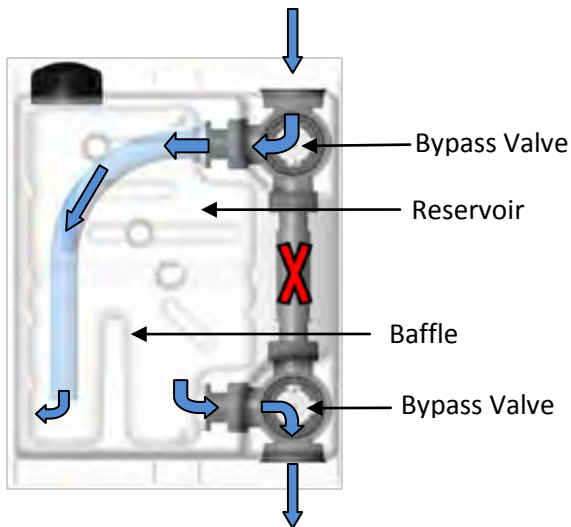

**FIGURE 2  
DORGPT-1  
DURING FLUSHING/PURGING**

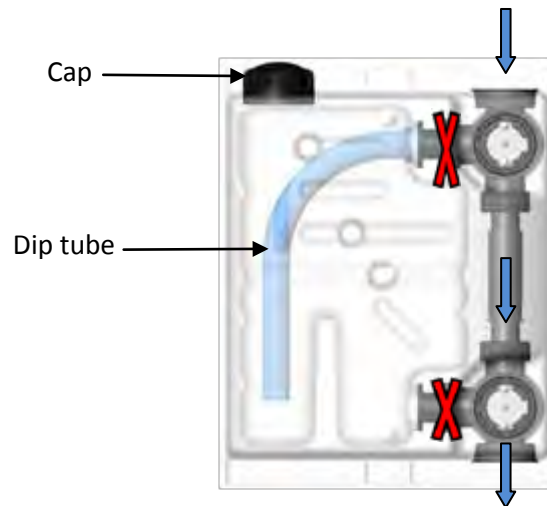

**FIGURE 3  
DIMENSIONAL INFORMATION**

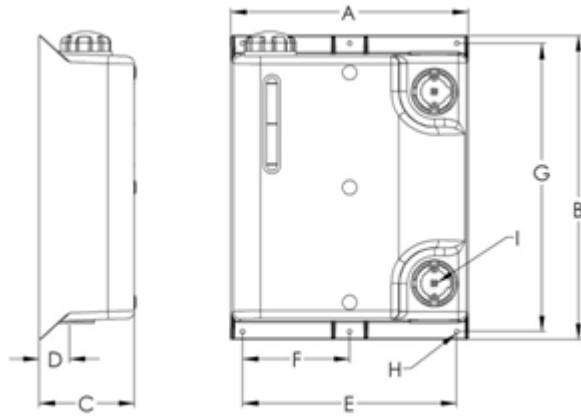

	A	B	C	D	E	F	G	H	I	WEIGHT	
<b>Inches</b>	15-1/4	19-1/2	6-1/8	2	13-3/4	6-7/8	18-1/2	1/4	3/8" DRIVE SOCKET	LBS	KG
<b>CM</b>	38.8	49.5	15.6	5.1	35.0	17.5	47.0	0.6		10	4.5

**INSTALLATION**

**Overview**

The DORGPT-1 must be mounted above the pump or flow center at a sufficient height to ensure the required suction head pressure of the circulator pump is met. It is critical for the Tank to be plumbed into the suction side of the flow center between the ground loop and the flow center. The pump or flow center can be mounted in any direction as long as the Tank is mounted above the flow center and is plumbed into the suction side

of the pump. The Tank includes an adapter for use with a Flo-Link double o-ring style flow center. A variety of fittings are available to allow the Tank to be connected to nearly any pump or flow center. If using a pump other than a Grundfos UP26-99 or UP26-116, it is your responsibility to determine the applicability of using the DORGPT-1 with the selected pump. This determination can be made by comparing the NPSHr of the pump to the NPSHa.

**FIGURE 4  
DORGPT-1 MOUNTED ABOVE FLOW CENTER**

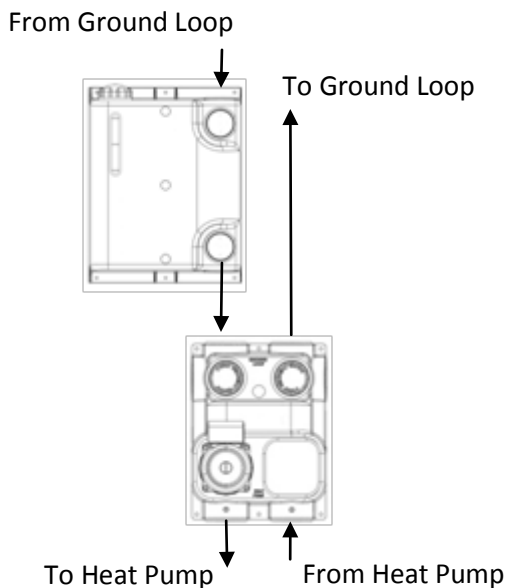

## STANDARD PROCEDURE

1. Attach the flow center or pump to a well supported structure such as a framed or concrete/masonry wall using appropriate mounting hardware. Be sure to mount the flow center low enough to allow the DORGPT-1 to be mounted above it. If the flow center is mounted on a framed wall, the mounting screws should be located into a stud, or into braces or a board that are attached to the studs. The flow center or pump **MUST** be mounted so that the pump's shaft is horizontal (Figure 5).

**FIGURE 5**  
**FLOW CENTER MUST BE INSTALLED SO PUMP'S SHAFT IS HORIZONTAL**

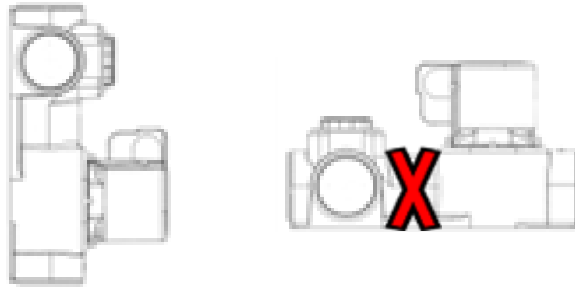

2. Insert the included Valve Coupling Adapter into the female port of the flow center or pump (Figure 6). Note that a 1" MPT X Flo-Link female fitting is available to transition to a 1" FPT flow center. Lubricate the o-rings on both ends of the Adapter to aid in installation. The Adapter should be pushed straight into the port. **DO NOT** rock the Adapter left-to-right or front-to-back in the female port of the flow center.

**FIGURE 6**  
**FLOW CENTER WITH VALVE COUPLING ADAPTER**  
**(A 1" MPT X Flo-Link fitting is available to transition to 1" FPT style flow centers.)**

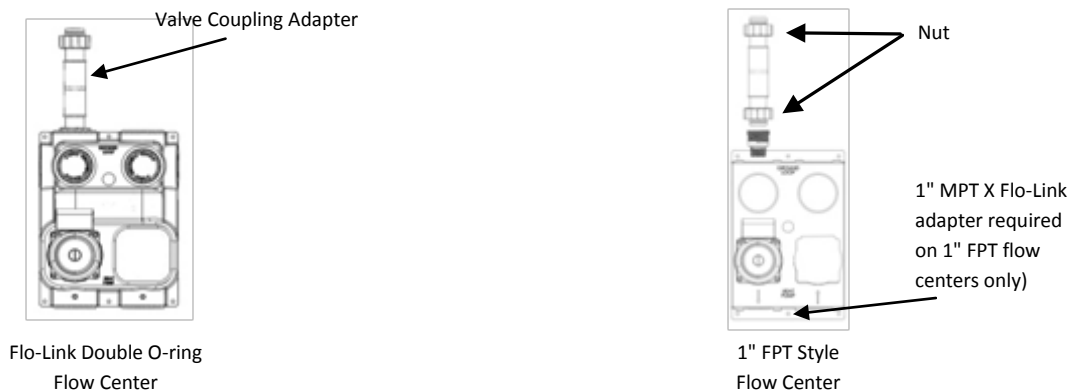

3. Hand-tighten the Nut to secure the Adapter to the flow center. **DO NOT** use a wrench or channel locks to tighten the Nut. The Adapter seals via the o-rings in the inner diameter of the valve port **NOT** with the threads between Nut and valve.

4. Slowly push the Tank onto the Adapter and hand-tighten the Nut to secure the Adapter to the flow center. DO NOT rock the Tank or Adapter, or use a wrench to tighten the Nut.

**FIGURE 7**  
**INSTALLING THE DORGPT-1 ONTO THE FLOW CENTER USING A VALVE COUPLING ADAPTER**

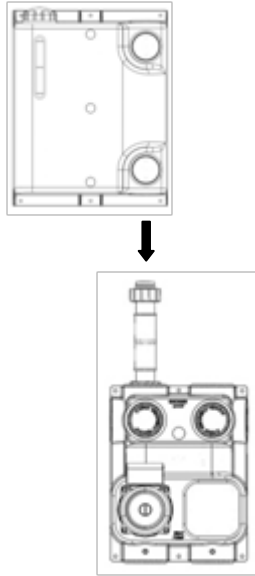

5. Attach the Tank to the wall using appropriate wall anchors as in Step 1. Be sure that the Adapter remains vertical (plumb).
6. Attach ground loop and heat pump plumbing to flow center and Tank.
7. Insulate all unit, flow center, and Tank piping, if necessary. In general, all inside piping should be insulated if the minimum loop temperature could drop below 50 F.

## FLUSHING AND PURGING

### NOTE:

This guide provides the installer with instructions specific to the DORGPT-1. Please refer to your heat pump manufacturer's instructions or IGSHPA guidelines for additional detailed flushing and purging information.

1. Remove DORGPT-1 and Valve Face Covers and tank fluid Cap (Figure 9).

**FIGURE 8**  
**DORGPT-1 CAP AND VALVE FACE COVERS**

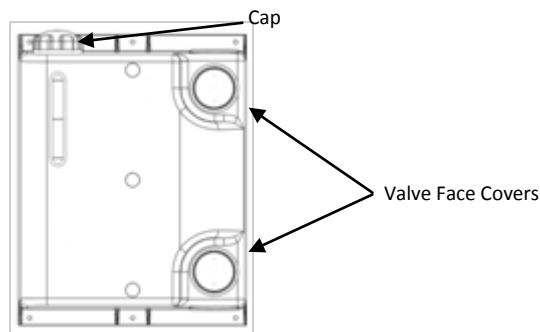

2. Rotate valves so that fluid will bypass the Reservoir (Figure 9).

**NOTE:** Valves must be in bypass position during system flushing/purging.

**FIGURE 9  
VALVE POSITION FOR FLUSHING/PURGING**

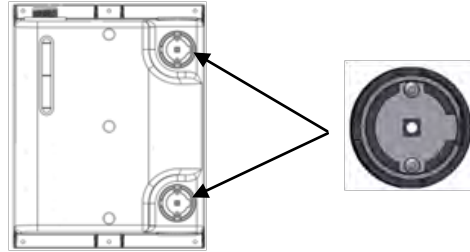

3. Attach flush cart to flow center flush ports.

4. Flush/purge the ground loop and heat pump according to heat pump manufacturer's and/or IGSHPA guidelines. The flush cart can be used to flush both the ground loop piping and unit side/interior piping.

**NOTE:** Fluid should not enter the reservoir of the Geo-Prime Tank during flushing. If it does, immediately stop flushing and check to be sure the bypass valves are in the correct orientation as shown in Figure 9.



**CAUTION:** Never DEAD-HEAD THE FLUSH CART PUMP INTO THE FLUID RESERVOIR OF THE GEO-PRIME TANK. OVER-PRESSURIZATION OF THE FLUID RESERVOIR COULD BE DANGEROUS AND WILL VOID THE WARRANTY.

5. Add Add antifreeze per heat pump manufacturer's suggested guidelines as required.

6. Turn off Turn off flush cart. **DO NOT PRESSURIZE LOOP!**

7. Rotate valves on flow center to operating position and disconnect the flush cart.

8. Fill DORGPT-1 reservoir with clean, debris free loop fluid. This can be the same pre-mixed fluid that remains in the flush cart after flushing. The reservoir can hold approximately 2.5 gallons of fluid.



9. Rotate valves on Geo-Prime Tank to operating position.

**FIGURE 10**  
**VALVE POSITION FOR SYSTEM OPERATION**

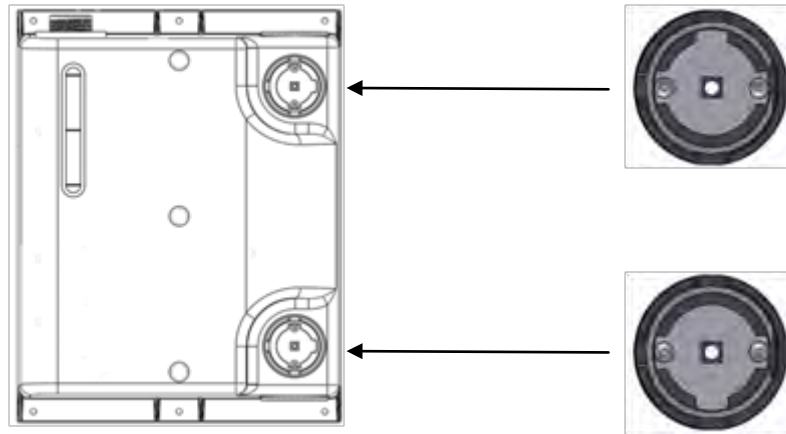

### **INITIAL START-UP**

1. Be sure flow center and DORGPT-1 valves are in the correct operating positions.
2. Open the vent screw in the center of the pump motor with a large flat head screwdriver allowing a few drops of fluid to drip out. Then, re-tighten the vent screw.

**NOTE: *This step is critical!*** Opening the vent screw and allowing fluid to drip out ensures that all trapped air has exited the pump motor. Skipping this important step could lead to premature pump failure.

3. Start flow center pump(s) and allow system to operate for several minutes. Add additional loop fluid, if necessary, while pumps are running.
4. Measure and record the flow rate as specified by the heat pump manufacturer. This is typically completed by measuring the pressure drop across the heat pump's heat exchanger via PT ports located at the water connections of the unit. The flow is then determined using the manufacturer's published tables for pressure drop versus flow. The flow rate can also be determined by utilizing a flow meter (see page 15). Verify the performance of the heat pump per the manufacturer's literature.
5. Replace Valve Face Covers and fluid Cap. Tighten the Cap until there is an audible "click" similar to an automobile's gas cap.

**NOTE: *Adding additional loop fluid may be necessary after initial system startup. One method of ensuring the proper loop fluid is added at a later date is for the installer to provide the system owner with a pre-mixed solution of loop fluid in a clearly marked, sealed, approved container that is stored in a safe, convenient location.***

## ADDING OR CHECKING FLUID

**NOTE:** In general you should not need to remove the Cap and it should only be removed when absolutely necessary. The Cap is intended to seal the ground loop system from the outside atmosphere thereby ensuring a closed system.



**WARNING:** Only use pre-mixed antifreeze in a non-flammable state. Failure to observe safety precautions may result in fire, injury, or death.



**CAUTION:** THE RESERVOIR MAY BE SLIGHTLY PRESSURIZED WHICH COULD CAUSE THE FLUID TO LEAK OUT WHEN THE CAP'S SEAL IS BROKEN (I.E., CAP IS LOOSENED). IN ADDITION, THE CAP SHOULD ONLY BE REMOVED WHEN THE CIRCULATOR PUMP IS RUNNING. WHEN THE CIRCULATOR STARTS, THE FLUID LEVEL IN THE RESERVOIR MAY DROP SLIGHTLY ALLOWING YOU TO REMOVE THE CAP WITHOUT OVERFLOWING THE TANK. THE CAP SHOULD BE REMOVED SLOWLY SO THAT IF FLUID DOES BEGIN TO EXIT THE RESERVOIR, IT CAN BE QUICKLY RE-TIGHTENED.

## DETERMINING FLUID LEVEL

The fluid level in the DORGPT-1 may be determined by viewing the fluid level through the sight window while the loop pumps are running. Depending on lighting conditions in the installation area, a small flashlight may be necessary. The fluid level may be higher than the viewing area spanned by the sight window (which is acceptable). The fluid level should always be above the midpoint of sight window.

If the fluid level cannot be determined via the sight window (for example, if the fluid level is above the sight window) the cap may be removed.

## CHECKING LOOP FLUID



**CAUTION:** THE GROUND LOOP FLUID MAY CONTAIN ANTIFREEZE SUCH AS METHANOL, ETHANOL, OR PROPYLENE GLYCOL. THESE ANTIFREEZE SOLUTIONS MAY CONTAIN SUBSTANCES THAT ARE HARMFUL OR TOXIC. APPROPRIATE PERSONAL PROTECTIVE EQUIPMENT (SAFETY GLASSES, PROTECTIVE GLOVES, ETC.) SHOULD BE UTILIZED TO AVOID CONTACT WITH THE LOOP FLUID.

The loop fluid can be checked to determine the freeze protection level by verifying the percentage of antifreeze in the system. One simple method of performing this check is to remove a small amount of loop fluid and checking the specific gravity with a hydrometer. The specific gravity is then compared to the charts provided by the antifreeze manufacturer.

The loop fluid can be extracted from the system by either 1) rotating the 3-way valve on the flow center and collecting the fluid from the flush port or 2) removing the Cap on the Tank and using a syringe, bulb, etc. to collect the fluid.

## ADDING LOOP FLUID



**CAUTION:** THE RESERVOIR MAY BE SLIGHTLY PRESSURIZED WHICH COULD CAUSE THE FLUID TO LEAK OUT WHEN THE CAP'S SEAL IS BROKEN (I.E. CAP IS LOOSENED). IN ADDITION, THE CAP SHOULD ONLY BE REMOVED WHEN THE CIRCULATOR PUMP IS RUNNING. WHEN THE CIRCULATOR STARTS, THE FLUID LEVEL IN THE RESERVOIR MAY DROP SLIGHTLY ALLOWING YOU TO REMOVE THE CAP WITHOUT OVERFLOWING THE TANK. THE CAP SHOULD BE REMOVED SLOWLY SO THAT IF FLUID DOES BEGIN TO EXIT THE RESERVOIR, IT CAN BE QUICKLY RE-TIGHTENED.

**NOTE:** Always be sure to add the proper loop fluid to your system. Many ground loop systems contain water and anti-freeze such as ethanol, methanol, or glycol in a concentration high enough to reach the system's required freeze protection. Adding a small amount of water may not seriously affect the freeze protection level but adding too much water will dilute the antifreeze and will affect the freeze protection (as in the case when you are adding water on a regular basis). In addition, many residential water supplies are high in minerals, contain bacteria, or have an inappropriate Ph level to be used in the ground loop system. Finally, mixing the wrong antifreeze in your ground loop system can cause considerable harm. One method of ensuring you are using the appropriate loop fluid is for the installer to provide the system owner with a pre-mixed solution of loop fluid in a clearly marked, sealed, approved container that is stored in a safe, convenient location.



**CAUTION:** THE GROUND LOOP FLUID MAY CONTAIN ANTIFREEZE SUCH AS METHANOL, ETHANOL, OR PROPYLENE GLYCOL. THESE ANTIFREEZE SOLUTIONS MAY CONTAIN SUBSTANCES THAT ARE HARMFUL OR TOXIC. APPROPRIATE PERSONAL PROTECTIVE EQUIPMENT (SAFETY GLASSES, PROTECTIVE GLOVES, ETC.) SHOULD BE UTILIZED TO AVOID CONTACT WITH THE LOOP FLUID.

1. With the ground loop pumps running, slowly remove the Cap from the Tank. If the Tank begins to overflow, quickly re-tighten the Cap. In this case, no additional loop fluid is necessary.
2. Fill the Reservoir with the appropriate loop fluid and replace the Cap. Tighten the Cap until there is an audible "click" similar to an automobile's gas cap.

## REPLACING A PUMP

1. Verify which pump(s) needs to be replaced.
2. Rotate both 3-way valves on flow center to isolate the pumps from the ground loop and Geo-Prime Tank.

**FIGURE 11**  
**VALVE POSITION TO ISOLATE GROUND LOOP FROM FLOW CENTER & HEAT PUMP**

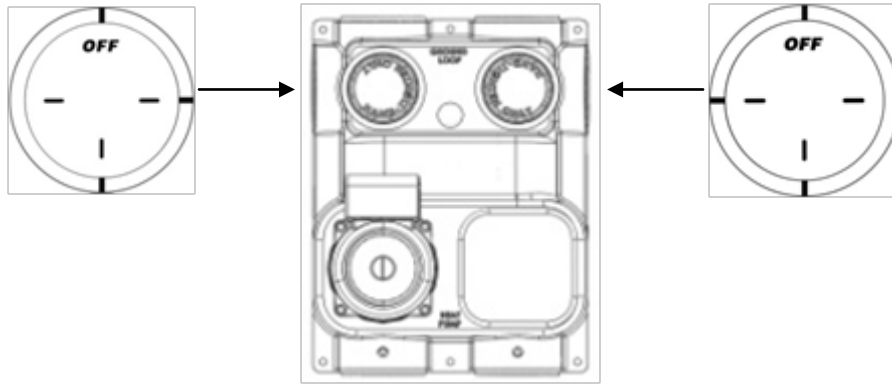

**WARNING:** OPEN THE POWER SUPPLY DISCONNECT SWITCH AND SECURE IT IN AN OPEN POSITION PRIOR TO PERFORMING ELECTRICAL WORK. VERIFY THE POWER HAS BEEN DISCONNECTED PRIOR TO WIRING THE PUMP. FAILING TO SECURE THE ELECTRICAL SUPPLY COULD RESULT IN SERIOUS INJURY OR DEATH.

3. Remove the defective power head. Be sure to have an absorbent cloth available to catch any water that exists the pump housing.
4. Carefully inspect the pump for possible causes of failure. For example, sand or debris in the pump housing indicates that the ground loop needs to be re-flushed.
5. Wipe any debris and fluid from the sealing surface of the pump housing.
6. Install new pump motor.
7. Flush the air that was introduced into the system using method A or B below:
  - A. Flushing unit with garden hose**
    - Verify 3-way valves are turned so that the flush port is open (i.e. ground loop isolated; see Figure 11).
    - Attach garden hose from domestic water supply to one of the valves and a drain hose to the other valve (Figure 12).

**FIGURE 12**  
**CONNECTIONS FOR FLUSHING HEAT PUMP SIDE OF SYSTEM WITH GARDEN HOSE**

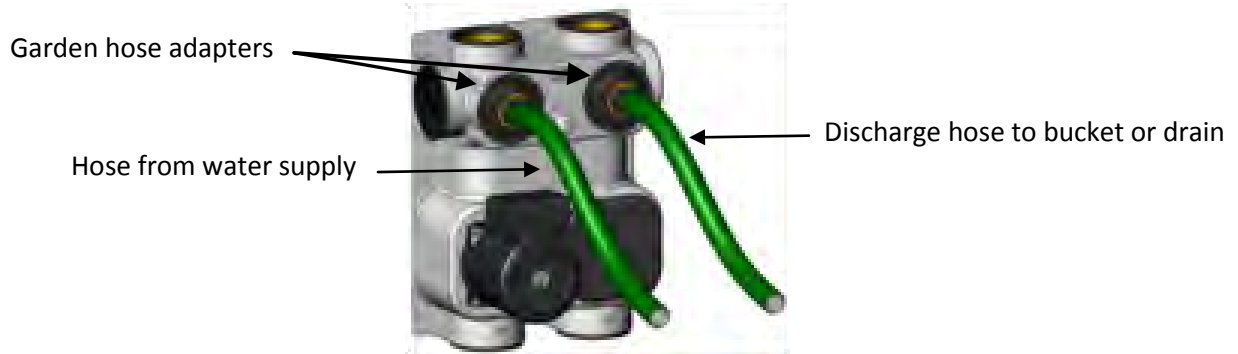

- Place the drain hose in a bucket or drain as appropriate.
- Turn on the water source and flush until the discharge water is free of air.
- Rotate the right side 3-way valve to the operating position. This stops the flow of water through the system. Turn off water supply.
- Rotate the other 3-way valve to the operating position.

**B. Flushing unit with circulator pump**

- Verify 3-way valves 3-way valves are turned so the flush port is open and the ground loop is isolated (see Figure 11).
- Rotate the upper valve on the Geo-Prime Tank to isolate the Tank from the ground loop (see Figure 13).
- Attach a discharge hose to the ride-side 3-way valve. This can be a short piece of garden hose, washing machine hose, or clear tubing with an appropriate adapter. (Figure 13).
- Place the discharge hose into the Geo-Prime Tank.
- Rotate the left side 3-way valve so that the flush port is OFF. This opens the valve to the Geo-Prime Tank (Figure 13).
- Open the pump's vent screw to allow water to fill the pump. Allow a few drops of water to escape and then re-tighten vent screw.
- Power on the circulator. The fluid will travel from the Tank, through the flow center and heat pump, and back into the top of the Tank via the discharge hose. Continue flushing until the return fluid is free of air.
- Turn off the circulator.
- Rotate the other 3-way valve to the operating position.

**FIGURE 13**  
**CONNECTIONS & VALVE POSITIONS FOR FLUSHING**  
**HEAT PUMP SIDE OF SYSTEM WITH THE CIRCULATOR**

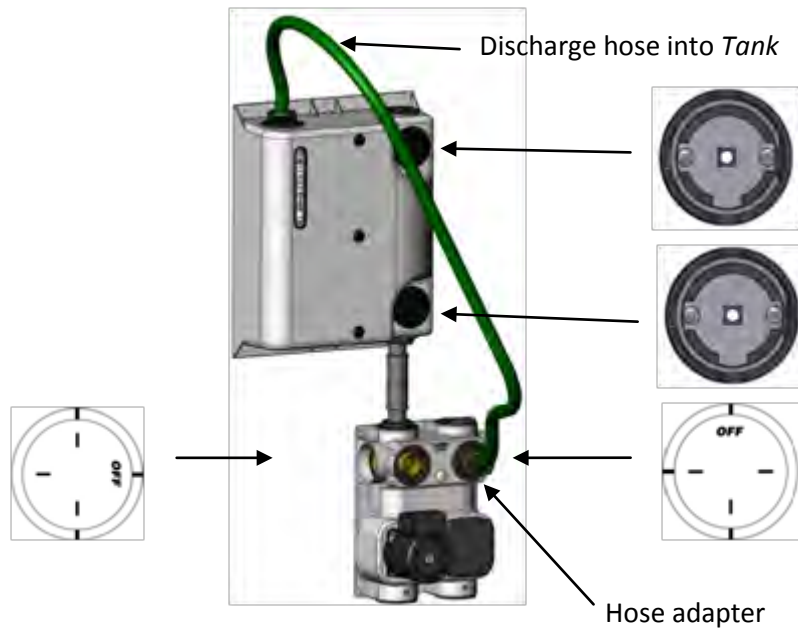

8. Rotate all valves to the operating positions
9. Proceed to “Initial Start-Up” on Page 9.

**FIGURE 14**  
**CONNECTIONS & VALVE POSITIONS FOR UTILIZING**  
**FLOW METER TOOL**

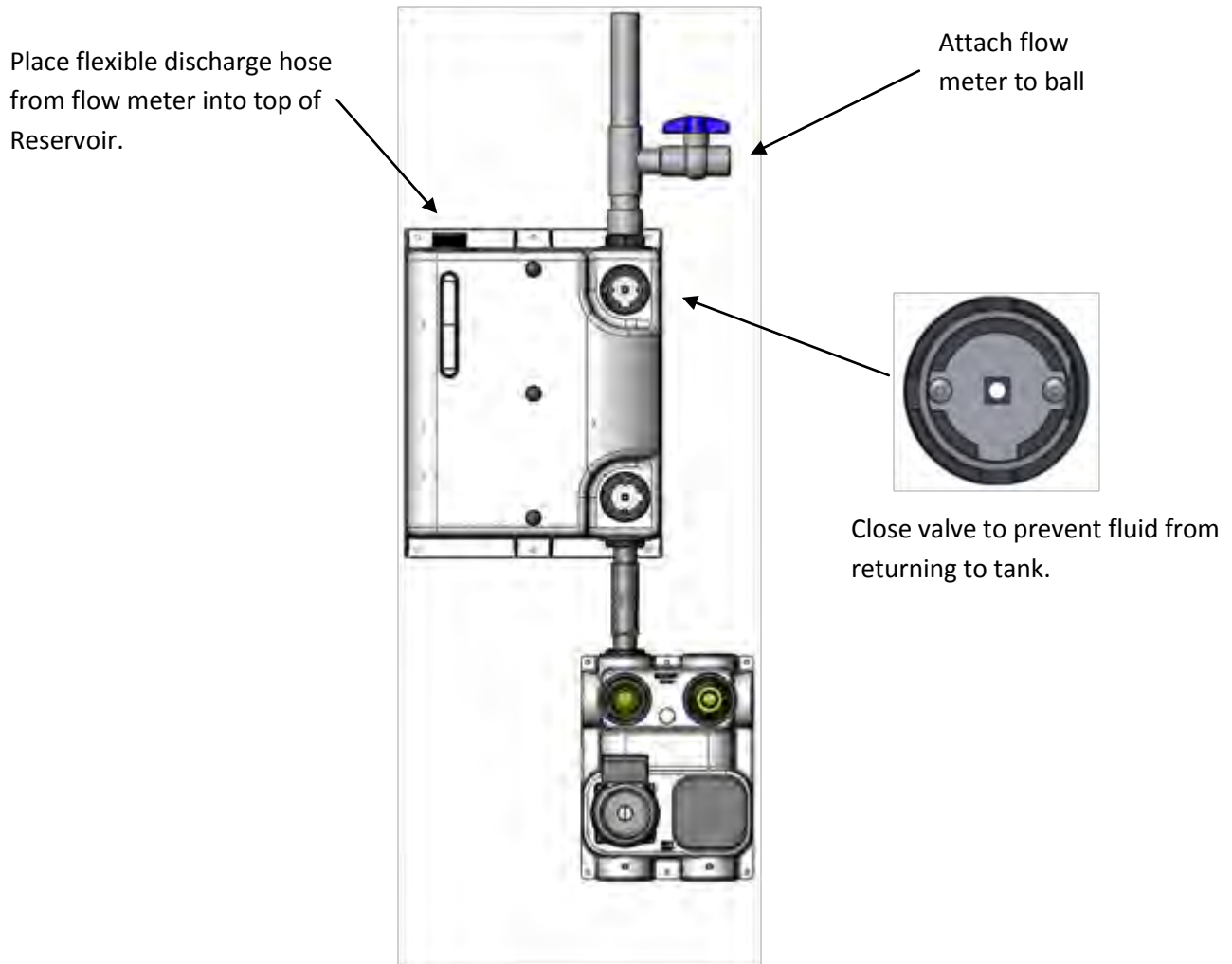

### **MEASURING FLOW RATE**

Flow rate through the ground loop can be measured by several methods. The standard method typically suggested by heat pump manufacturers is to measure the pressure drop across the heat pump's heat exchanger via PT ports located at the water connections of the unit. The flow rate is then determined using the manufacturer's published tables for pressure drop versus flow.

The flow rate can also be determined by utilizing a flow meter. Traditionally flow meters have not been installed on geothermal systems due to their high cost and potential to cause unnecessary call backs (leak from the meter, failure of the meter, etc). However, installers can utilize a removable flow meter tool to measure system flow rate with the Geo-Prime system.

To allow this simply install an additional tee and ball valve on the return line of the inside piping during system installation (Figure 14). Install the flow meter by connecting one end to the ball valve and placing the discharge hose into the top of the Reservoir. Close the 3-way valve, open the ball valve, and turn on the pump. The flow rate can then be read directly on the flow meter. To prevent tampering or accidental discharge of loop fluid, the ball valve handle should be removed and/or a plug placed in the end for a secondary seal.

## TROUBLESHOOTING

The following table relates to issues with the Geo-Prime Tank only. Please consult your manufacturer's flow center/heat pump installation manual for additional troubleshooting information

Problem	Possible Cause	Solution
Water leaks out Cap	Tank over-pressurized  Cap not sealing	Remove loop fluid.  Remove cap; clean reservoir neck and cap gasket; replace cap.  Remove cap; apply lubricant to cap gasket; replace cap.
Water leaks out valve face	Debris in valve	Rotate valve 360 degrees.  Remove valve spool; clean valve body and spool; replace o-ring(s) on valve spool if necessary.
Water drips around o-ring adapter/fittings	Condensation  O-ring seal failure  Pipe misalignment; side-loading o-rings	Insulate piping.  Remove fitting; clean valve port and fittings; replace o-rings if necessary.  Remove fittings; check o-rings and replace if necessary; align piping.
Noise in reservoir	Air in loop system passing into reservoir  Low water level in reservoir	Not a problem. Monitor fluid level; add fluid if necessary.  Add loop fluid.
Low water level in reservoir	Air from loop system deposited into reservoir  Pipe expansion  Leak in ground loop system	Not a problem; add loop fluid.  Not a problem; add loop fluid if necessary.  Locate and repair leak.
No flow to/from Tank	Valve(s) in wrong position	Rotate valve(s) to operating position.
Air not separating from fluid	Valve(s) in wrong position	Rotate valve(s) to operating position.