INSTALLATION INSTRUCTIONS

WALL MOUNTED PACKAGE AIR CONDITIONERS with DC Powered Blower & Economizer

MODELS

D3SA2	D3SL2
D4SA2	D4SL2
D5SA2	D5SL2
D36A2	D36L2
D42A2	D42L2
D48A2	D48L2
D60A2	D60L2

**NOTE: THE RECOMMENDED CONTROLLERS FOR THESE MODELS INCLUDE
A BARD MV4000 CONTROLLER PLUS AN MVH-1 HUMIDISTAT ACCESSORY.**



Bard Manufacturing Company, Inc.
Bryan, Ohio 43506
Since 1914...Moving ahead just as planned.

Manual : 2100-612A
Supersedes: 2100-612
File: Volume III Tab 17
Date: 03-27-14

Contents

Getting Other Information and Publications	3
ANSI Z535.5 Definitions	4
Wall Mount General Information	
Wall Mount Model Nomenclature	5
Shipping Damage	5
General	5
Duct Work	6
Filters	6
Condensate Drain	6
Installation Instructions	
Wall Mounting Information	7
Mounting the Unit.....	7
Placement	7
Clearances Required	7
Minimum Clearances	7
Wiring – Main Power.....	13
Wiring – Low Voltage Wiring.....	13

Figures	
Figure 1 Unit Dimensions	8
Figure 2 Mounting Instructions	9
Figure 3 Electric Heat Clearance	10
Figure 4 Wall Mounting Instructions	11
Figure 5 Wall Mounting Instructions	11
Figure 6 Common Wall Mounting Installations	12
Figure 7 Wiring Main Power	13
Figure 8 Low Voltage Connection	14
Figure 9 Measuring Trigger Voltage	21
Figure 10 Control Locations	22
Figure 11 Fan Blade Setting.....	28

Start Up	
General	15
Topping Off System Charge.....	15
Safety Practices	15
Important Installer Note.....	16
Compressor Control Module	16
Adjustments	16
Three Phase Scroll Compressor.....	17
Phase Monitor.....	17
Service Hints.....	17
Sequence of Operation	18
Call for Indoor Blower	18
First Call for Cooling	18
Second Call for Cooling	18
Call for Heating	19
Loss of Utility Power	19
Troubleshooting	
52 VDC Indoor Blower Motor	20
Motor Trigger Voltage Circuit	21
Economizer Troubleshooting	23-26
Checking Temperature Sensor	27
Fan Blade Setting Dimensions.....	28
Removal of Fan Shroud.....	28
R-410A Refrigerant Charge	28

Tables	
Table 1 Troubleshooting.....	20
Table 2 Blower Trigger Voltage Chart	21
Table – Temperature F vs. Resistance	27
Table 3 Fan Blade Dimension.....	28
Table 4A Air Temp. Entering Outdoor Coil	29
Table 4B Air Temp. Entering Outdoor Coil	29
Table 5A Electrical Specifications	30
Table 5B Electrical Specifications.	30
Table 6 Indoor Blower Performance	31

GETTING OTHER INFORMATION AND PUBLICATIONS

These publications can help you install the air conditioner or heat pump. You can usually find these at your local library or purchase them directly from the publisher. Be sure to consult current edition of each standard.

National Electrical Code ANSI/NFPA 70

Standard for the Installation ANSI/NFPA 90A
of Air Conditioning and Ventilating Systems

Standard for Warm Air ANSI/NFPA 90B
Heating and Air Conditioning Systems

Load Calculation for ACCA Manual J
Residential Winter and Summer Air Conditioning

Duct Design for Residential ACCA Manual D
Winter and Summer Air Conditioning and Equipment
Selection

FOR MORE INFORMATION, CONTACT THESE PUBLISHERS:

ACCA **Air Conditioning Contractors of America**
1712 New Hampshire Ave. N.W.
Washington, DC 20009
Telephone: (202) 483-9370
Fax: (202) 234-4721

ANSI **American National Standards Institute**
11 West Street, 13th Floor
New York, NY 10036
Telephone: (212) 642-4900
Fax: (212) 302-1286

ASHRAE **American Society of Heating, Refrigeration
and Air Conditioning Engineers, Inc.**
1791 Tullie Circle, N.E.
Atlanta, GA 30329-2305
Telephone: (404) 636-8400
Fax: (404) 321-5478

NFPA **National Fire Protection Association**
Batterymarch Park
P.O. Box 9101
Quincy, MA 02269-9901
Telephone: (800) 344-3555
Fax: (617) 984-7057

ANSI Z535.5 Definitions:

- **Danger:** Indicate[s] a hazardous situation which, if not avoided, will result in death or serious injury. The signal word “DANGER” is to be limited to the most extreme situations. DANGER [signs] should not be used for property damage hazards unless personal injury risk appropriate to these levels is also involved.
- **Warning:** Indicate[s] a hazardous situation which, if not avoided, could result in death or serious injury. WARNING [signs] should not be used for property damage hazards unless personal injury risk appropriate to this level is also involved.
- **Caution:** Indicate[s] a hazardous situation which, if not avoided, could result in minor or moderate injury. CAUTION [signs] without a safety alert symbol may be used to alert against unsafe practices that can result in property damage only.
- **Notice:** [this header is] preferred to address practices not related to personal injury. The safety alert symbol shall not be used with this signal word. As an alternative to “NOTICE” the word “CAUTION” without the safety alert symbol may be used to indicate a message not related to personal injury.



WALL MOUNT GENERAL INFORMATION

AIR CONDITIONING WALL MOUNT MODEL NOMENCLATURE

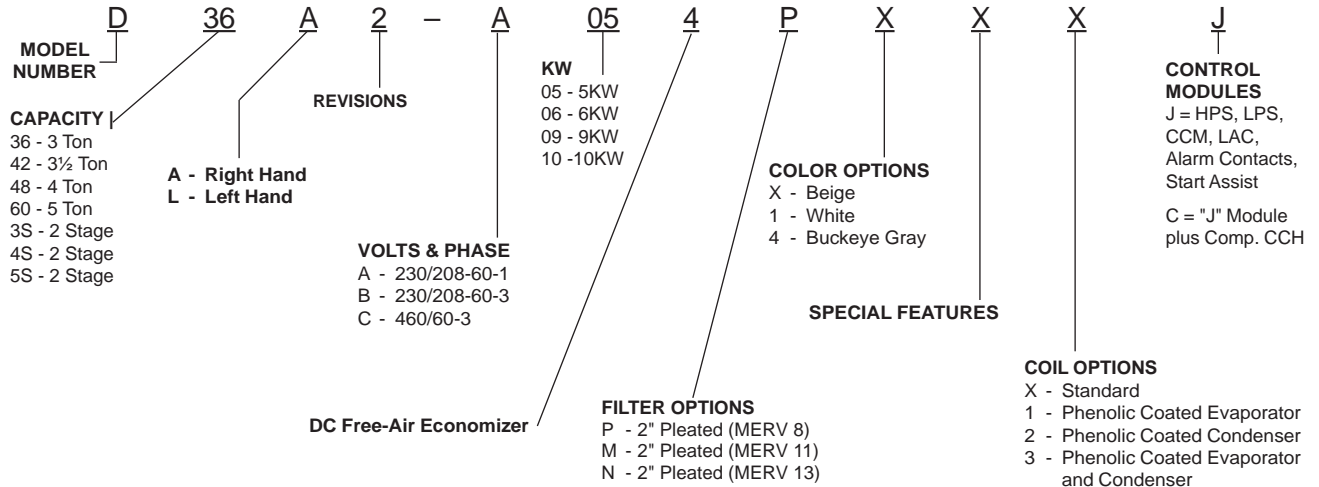

SHIPPING DAMAGE

Upon receipt of equipment, the carton should be checked for external signs of shipping damage. If damage is found, the receiving party must contact the last carrier immediately, preferably in writing, requesting inspection by the carrier's agent.

GENERAL

The equipment covered in this manual is to be installed by trained, experienced service and installation technicians.

The refrigerant system is completely assembled and charged. All internal wiring is complete.

The unit is designed for use with or without duct work. Flanges are provided for attaching the supply and return ducts.

These instructions explain the recommended method to install the air cooled self-contained unit and the electrical wiring connections to the unit.

These instructions and any instructions packaged with any separate equipment required to make up the entire air conditioning system should be carefully read before beginning the installation. Note particularly "Starting Procedure" and any tags and/or labels attached to the equipment.

While these instructions are intended as a general recommended guide, they do not supersede any national and/or local codes in any way. Authorities having jurisdiction should be consulted before the installation is made. See Page 3 for information on codes and standards.

Size of unit for a proposed installation should be based on heat loss/gain calculation made according to methods of Air Conditioning Contractors of America (ACCA). The air duct should be installed in accordance with the Standards of the National Fire Protection Association for the Installation of Air Conditioning and Ventilating Systems of Other Than Residence Type, NFPA No. 90A, and Residence Type Warm Air Heating and Air Conditioning Systems, NFPA No. 90B. Where local regulations are at a variance with instructions, installer should adhere to local codes.

DUCT WORK

All duct work, supply and return, must be properly sized for the design airflow requirement of the equipment. Air Conditioning Contractors of America (ACCA) is an excellent guide to proper sizing. All duct work or portions thereof not in the conditioned space should be properly insulated in order to both conserve energy and prevent condensation or moisture damage.

Design the duct work according to methods given by the Air Conditioning Contractors of America (ACCA). When duct runs through unheated spaces, it should be insulated with a minimum of one inch of insulation. Use insulation with a vapor barrier on the outside of the insulation. Flexible joints should be used to connect the duct work to the equipment in order to keep the noise transmission to a minimum.

A 1/4 inch clearance to combustible material for the first three feet of duct attached to the outlet air frame is required. See Wall Mounting Instructions and Figures 2 and 3.

Ducts through the walls must be insulated and all joints taped or sealed to prevent air or moisture entering the wall cavity.

Some installations may not require any return air duct. A metallic return air grille is required with installations not requiring a return air duct. The spacing between louvers on the grille shall not be larger than 5/8 inch.

Any grille that meets with 5/8 inch louver criteria may be used. It is recommended that Bard Return Air Grille Kit RG2 through RG5 or RFG2 through RFG5 be installed when no return duct is used. Contact distributor or factory for ordering information. If using a return air filter grille, filters must be of sufficient size to allow a maximum velocity of 400 fpm.

NOTE: If no return air duct is used, applicable installation codes may limit this cabinet to installation only in a single story structure.

FILTERS

A 2" MERV 8 pleated throwaway filter is standard with each unit. The filter slides into position making it easy to service. This filter can be serviced from the outside by removing the filter access panel. 2" MERV 11 & MERV 13 pleated filters are also available as optional accessories.

CONDENSATE DRAIN

A plastic drain hose extends from the drain pan at the top of the unit down to the unit base. There are openings in the unit base for the drain hose to pass through. In the event the drain hose is connected to a drain system of some type, it must be an open or vented type system to assure proper drainage.

INSTALLATION INSTRUCTIONS

WALL MOUNTING INFORMATION

1. Two holes for the supply and return air openings must be cut through the wall as shown in Figure 2.
2. On wood frame walls, the wall construction must be strong and rigid enough to carry the weight of the unit without transmitting any unit vibration.
3. Concrete block walls must be thoroughly inspected to insure that they are capable of carrying the weight of the installed unit.



WARNING

UNIT FALLING HAZARD

Use only sufficiently-rated mechanical lifting means with proper rigging to raise the unit for mounting. Failure to follow this Warning could result in injury or death!

MOUNTING THE UNIT

1. These units are secured by wall mounting flanges which secure the unit to the outside wall surface at both sides. A bottom mounting bracket, attached to skid for shipping, is provided for ease of installation, but is not required.
2. The unit itself is suitable for 0 inch clearance, but the supply air duct flange and the first 3 feet of supply air duct require a minimum of 1/4 inch clearance to combustible material. However, it is generally recommended that a 1-inch clearance is used for ease of installation and maintaining the required clearance to combustible material. See Figure 3 for details on opening sizes.
3. Locate and mark lag bolt locations and bottom mounting bracket location. See Figure 2.
4. Mount bottom mounting bracket.
5. Hook top rain flashing, attached to front - right of supply flange for shipping, under back bend of top.
6. Position unit in opening and secure with 5/16 lag bolts; use 7/8 inch diameter flat washers on the lag bolts.

Clearances Required for Service Access and Adequate Condenser Airflow

MODELS	LEFT SIDE	RIGHT SIDE
All covered by this Manual.	20"	20"



WARNING

All Models covered by this Manual require 1/4" clearance to the first 3 feet of duct to any combustible materials. Failure to provide this could result in fire causing damage, injury or death!

7. Secure rain flashing to wall and caulk across entire length of top. See Figure 2.
8. For additional mounting rigidity, the return air and supply air frames or collars can be drilled and screwed or welded to the structural wall itself (depending upon wall construction). Be sure to observe required clearance if combustible wall.

PLACEMENT

1. On side-by-side installations, maintain a minimum of 20 inches clearance on right side to allow access to control panel and heat strips, and to allow proper airflow to the outdoor coil. Additional clearance may be required to meet local or national codes.
2. Care should be taken to ensure that the recirculation and obstruction of condenser discharge air does not occur. Recirculation of condenser discharge air can be from either a single unit or multiple units. Any object such as shrubbery, a building or a large object can cause obstructions to the condenser discharge air. Recirculation or reduced airflow caused by obstructions will result in reduced capacity, possible unit pressure safety lockouts and reduced unit service life.

Units with a blow through condenser, such as the D-Series units, it is recommended there be a minimum distance of 10 feet between the front of the unit and any barrier or 20 feet between the fronts of two opposing (facing) units.

Minimum Clearances Required to Combustible Materials

MODELS	SUPPLY AIR DUCT FIRST THREE FEET	CABINET
All covered by this Manual.	1/4"	0"

FIGURE 1

Dimensions of Basic Unit for Architectural and Installation Requirements (Nominal)

Model	Width (W)	Depth (D)	Height (H)	Supply		Return																
				A	B	C	B	E	F	G	I	J	K	L	M	N	O	P	Q	R	S	T
D3SA/L D36A/L D42A/L	42.075	22.432	84.875	9.88	29.88	15.88	29.88	43.88	13.56	31.66	30.00	32.68	26.94	34.69	32.43	3.37	43.00	23.88	10.00	1.44	16.00	1.88
D4SA/L D5SA/L D48A/L D60A/L	42.075	22.432	93.000	9.88	29.88	15.88	29.88	43.88	13.56	37.00	30.00	40.81	35.06	42.81	40.56	3.37	43.00	31.00	10.00	1.44	16.00	10.00

All dimensions are in inches. Dimensional drawings are not to scale.

DA
RIGHT
HAND
UNIT**

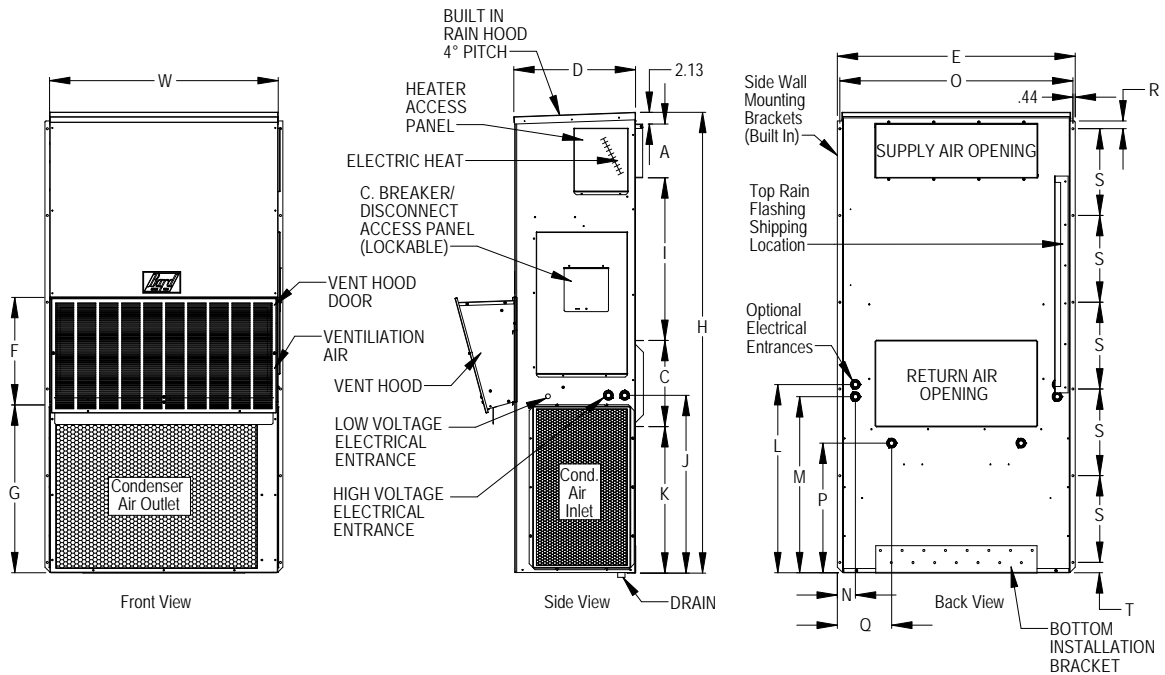

MIS-3352

DL
LEFT
HAND
UNIT**

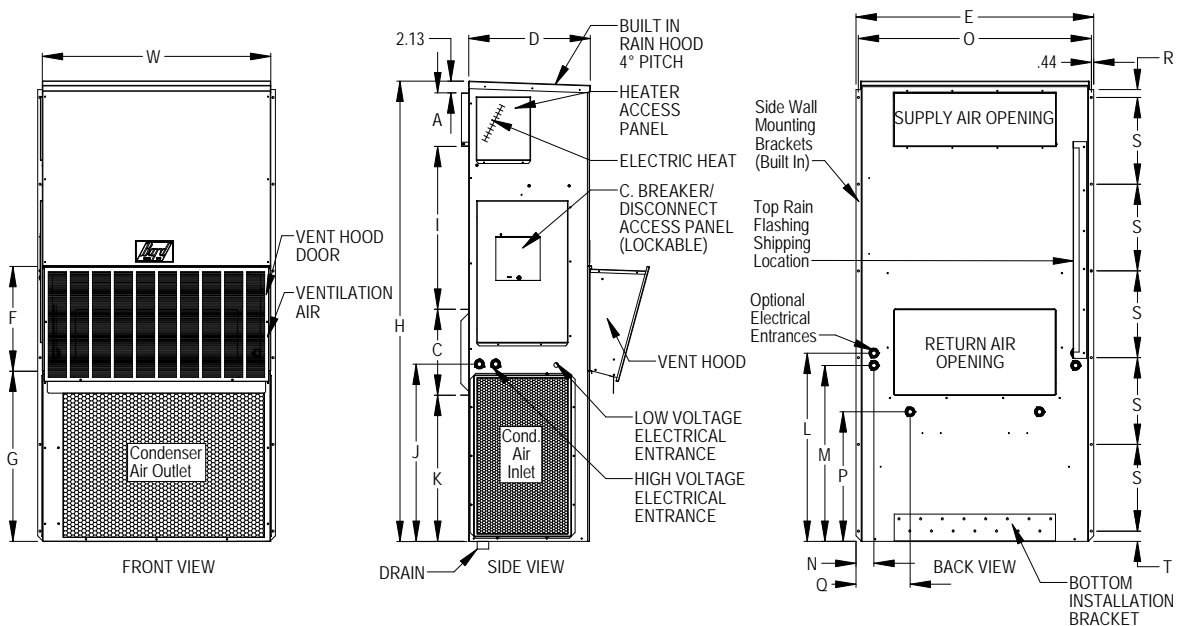

MIS-3353

**FIGURE 2
MOUNTING INSTRUCTIONS**

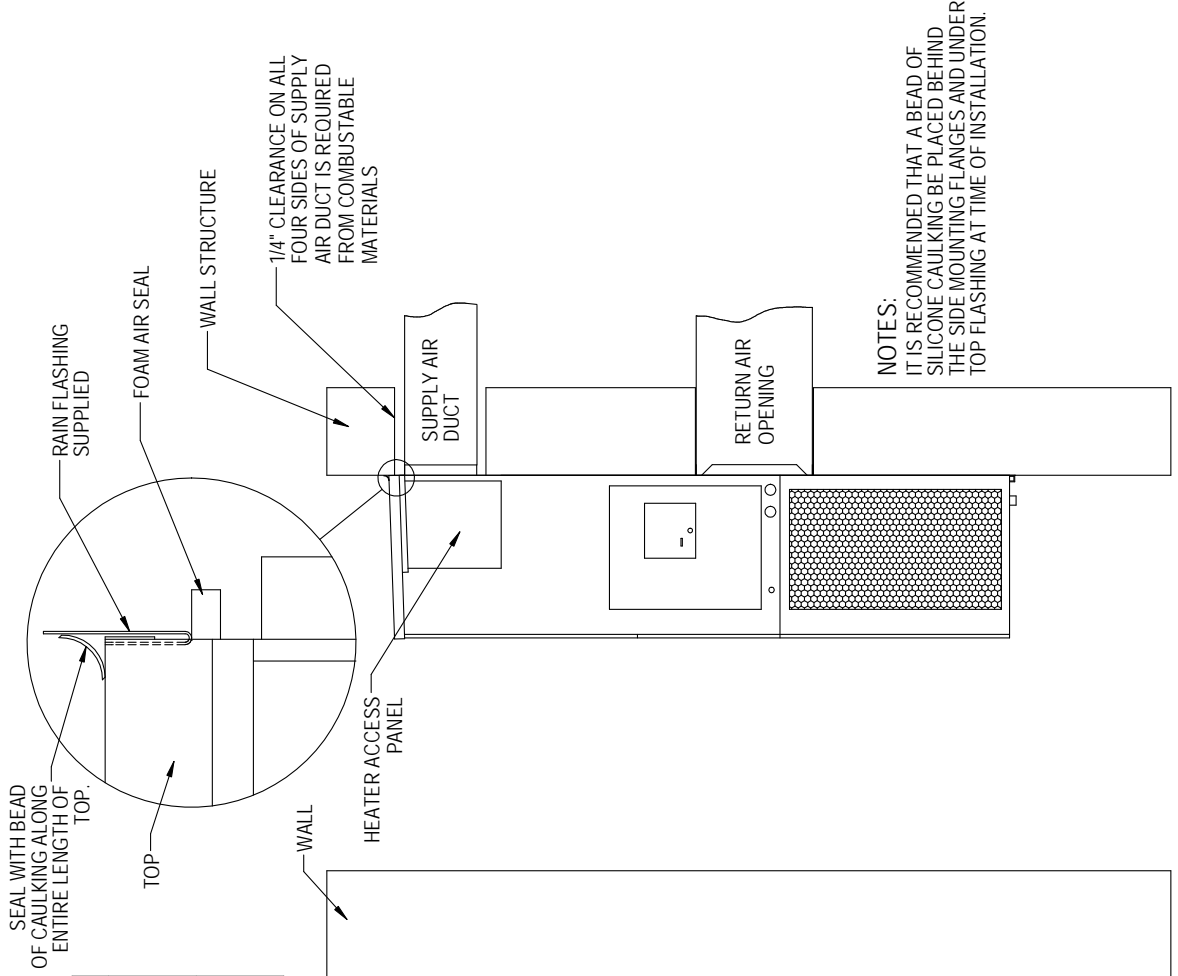

	A	B	C	D	E
REQUIRED DIMENSIONS TO MAINTAIN 1/4" MIN. CLEARANCE FROM COMBUSTIBLE MATERIALS	30 1/2	10 1/2	6 1/4	1 1/4	29 3/4
REQUIRED DIMENSIONS TO MAINTAIN RECOMMENDED 1" CLEARANCE FROM COMBUSTIBLE MATERIALS	32	12	5 1/2	2	29

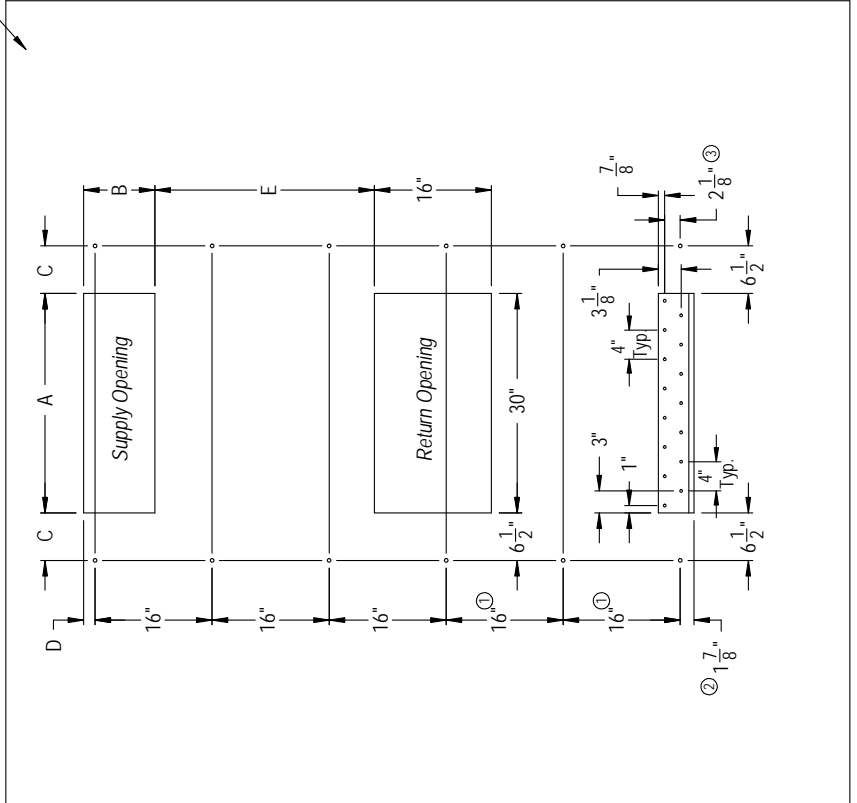

Right Side View

Wall Opening and Hole Location View

**FIGURE 3
ELECTRIC HEAT CLEARANCE**

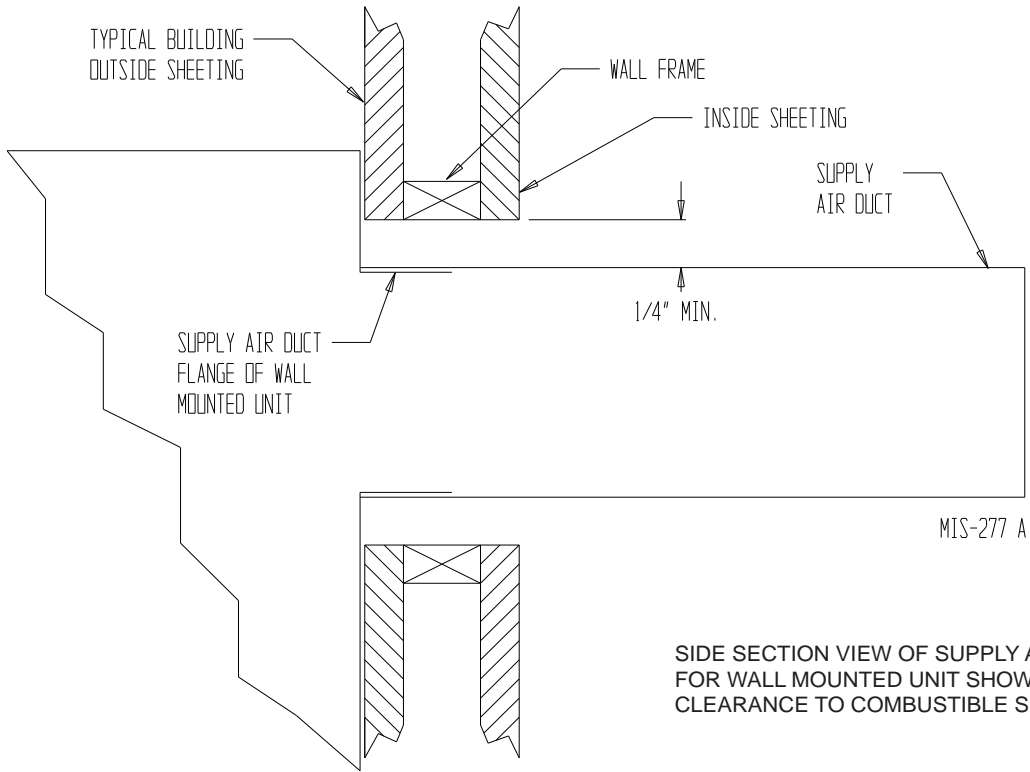

SIDE SECTION VIEW OF SUPPLY AIR DUCT FOR WALL MOUNTED UNIT SHOWING 1/4 INCH CLEARANCE TO COMBUSTIBLE SURFACES.

⚠ WARNING

A *minimum* of 1/4 inch clearance must be maintained between the supply air duct and combustible materials. This is required for the first 3 feet of ducting.

It is important to ensure that the 1/4 inch minimum spacing is maintained at all points.

Failure to do this could result in overheating the combustible material and may result in a fire causing damage, injury or death!

⚠ WARNING

UNIT FALLING HAZARD
Failure to follow this Warning & bolt the unit to the wall could cause injury or death! Follow all mounting instructions.

⚠ WARNING

All Models covered by this Manual require 1/4" clearance to the first 3 feet of duct to any combustible materials. Failure to provide this could result in fire causing damage, injury or death!

FIGURE 4 WALL MOUNTING INSTRUCTIONS

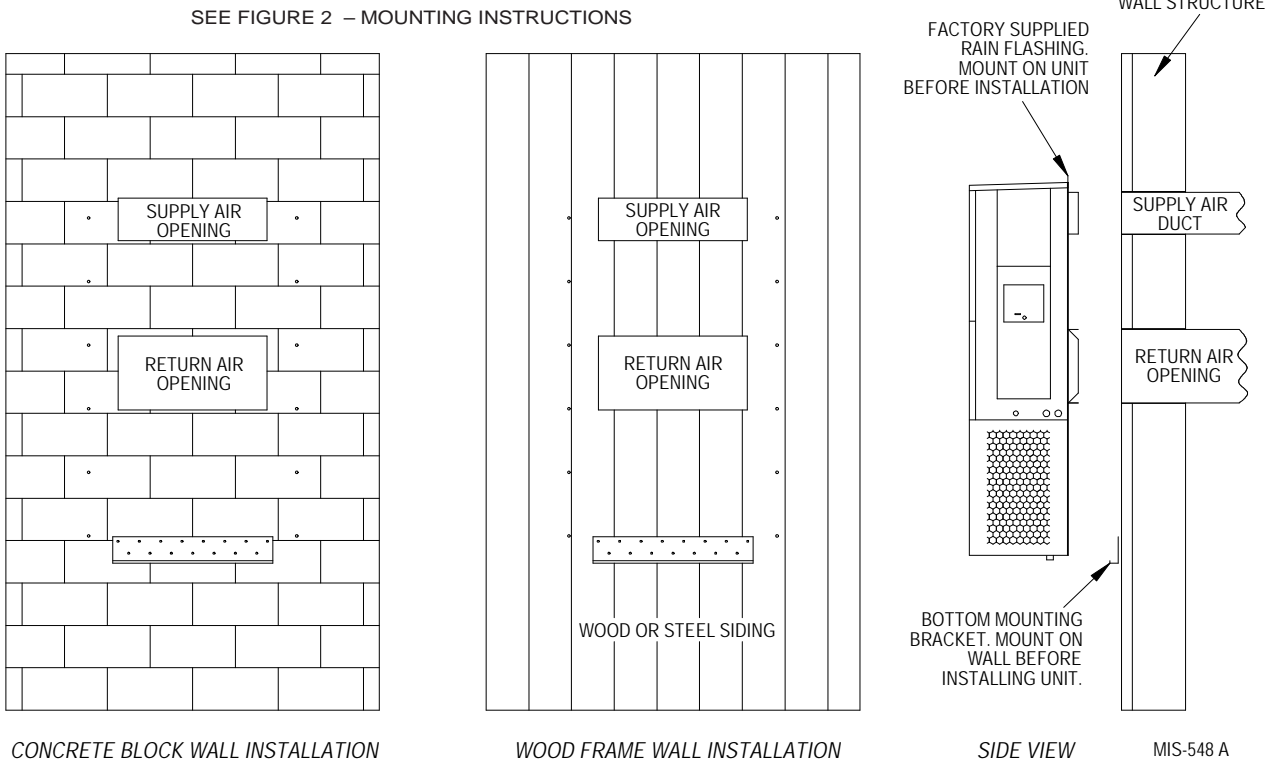
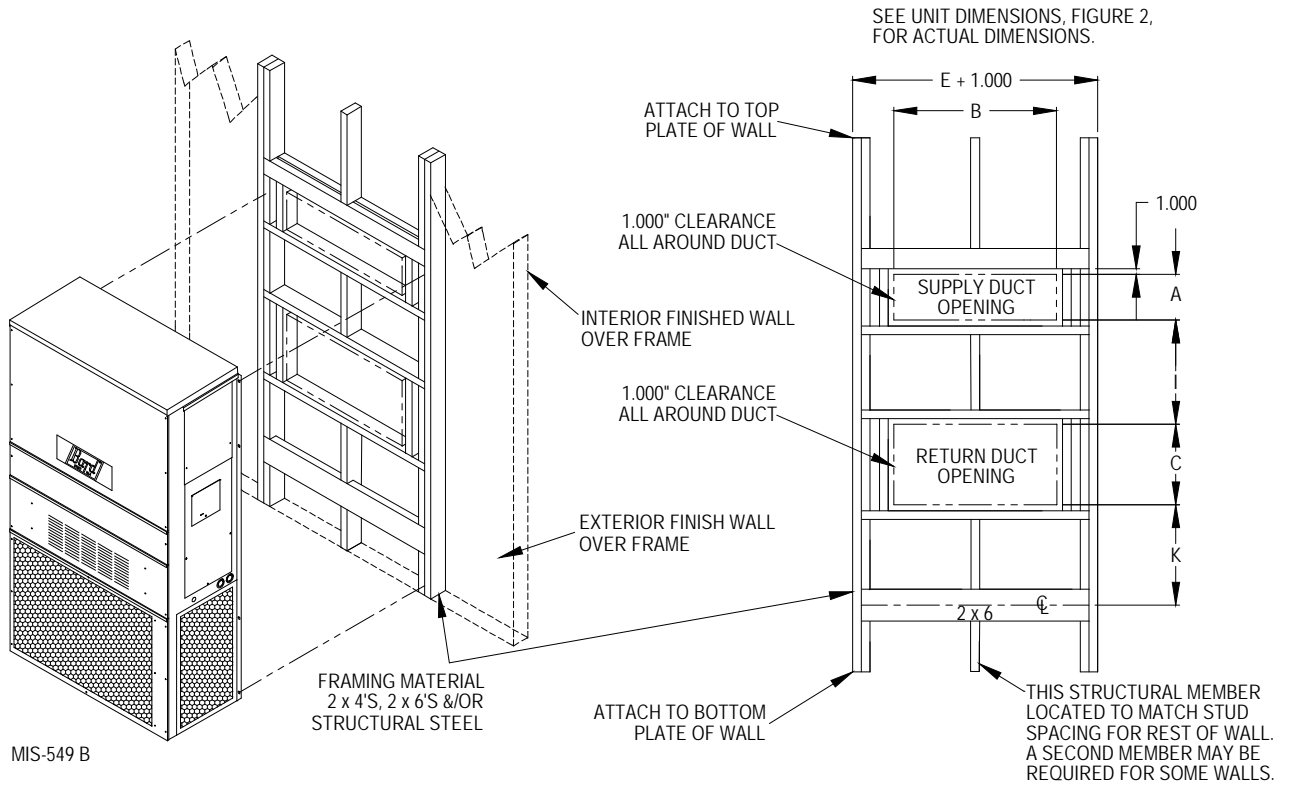
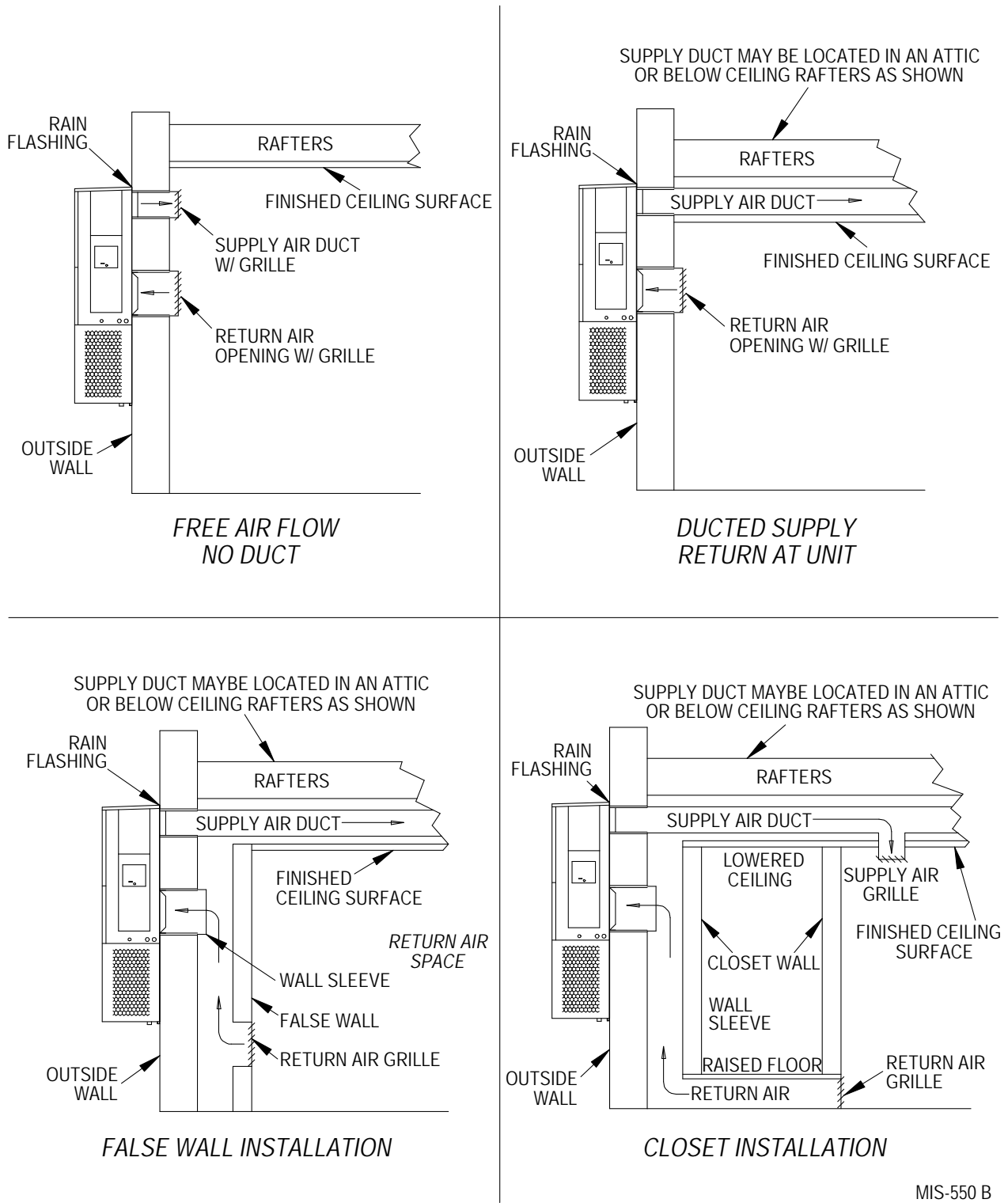

FIGURE 5 WALL MOUNTING INSTRUCTIONS



**FIGURE 6
COMMON WALL MOUNTING INSTALLATIONS**



MIS-550 B

WIRING – MAIN POWER

NOTICE

All Models covered by this Installation Instruction require dual power sources. One is the VAC utility power to run the compressor and outdoor fan motor. Two, is 52 Vdc power to operate the indoor blower and economizer.

Refer to the unit rating plate for wire sizing information and maximum fuse or “HACR” type circuit breaker size. Each outdoor unit is marked with a “Minimum Circuit Ampacity”. This means that the field wiring used must be sized to carry that amount of current. All models are suitable only for connection with copper wire. Each unit and/or wiring diagram will be marked “Use Copper Conductors Only”. These instructions **must be** adhered to. Refer to the National Electrical Code (NEC) for complete current carrying capacity data on the various insulation grades of wiring material. All wiring must conform to NEC and all local codes.

The electrical data lists fuse and wire sizes (75°C copper) for all models including the most commonly used heater sizes. Also shown are the number of field power circuits required for the various models with heaters.

The unit rating plate lists a “Maximum Time Delay Relay Fuse” or “HACR” type circuit breaker that is to be used with the equipment. The correct size must be used for proper circuit protection and also to assure that there will be no nuisance tripping due to the momentary high starting current of the compressor motor.

The disconnect access door on this unit may be locked to prevent unauthorized access to the disconnect. To convert for the locking capability, bend the tab located in the bottom left-hand corner of the disconnect opening under the disconnect access panel straight out. This tab will now line up with the slot in the door. When shut, a padlock may be placed through the hole in the tab preventing entry.

See “Start Up” section for important information on three phase scroll compressor start ups.

See Tables 5A & 5B for Electrical Specifications. See Figure 7 to reference VAC and VDC Landing Points.

WIRING – LOW VOLTAGE WIRING

Bard recommends usage of Bard MV4000 Controller, plus the MVH-1 Humidistat Accessory for application to these models. Since the control system for the economizers is dry bulb differential, to maximize the hours of free cooling, the MVH-1 Humidistat Accessory will limit the internal shelter humidity levels by forcing mechanical cooling when humidity levels rise above the setpoint. See Figure 8 for the connection diagram.

230/208V, 1 phase and 3 phase equipment dual primary voltage transformers. All equipment leaves the factory wired on 240V tap. For 208V operation, reconnect from 240V to 208V tap. The acceptable operating voltage range for the 240 and 208V taps are:

TAP	RANGE
240	253 – 216
208	220 – 187

NOTE: The voltage should be measured at the field power connection point in the unit and while the unit is operating at full load (maximum amperage operating condition).

**FIGURE 7
WIRING MAIN POWER**

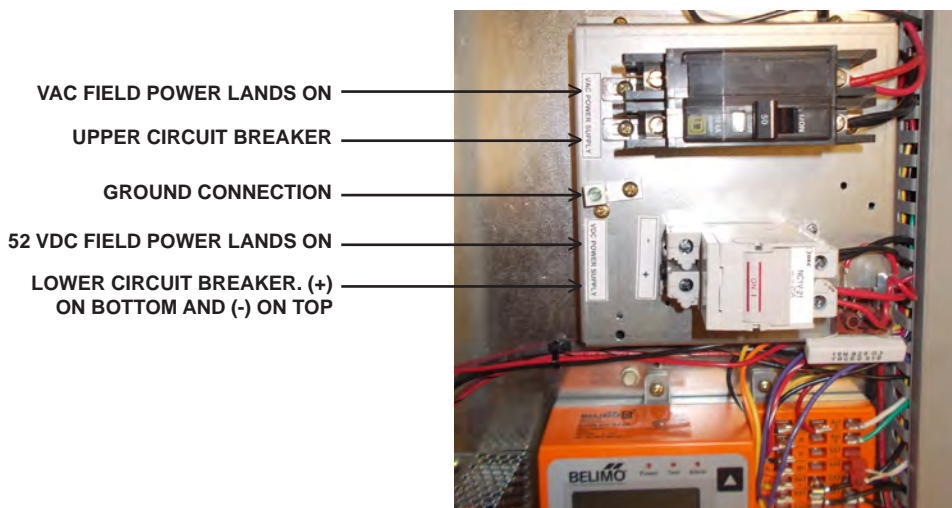

**FIGURE 8
LOW VOLTAGE CONNECTIONS**

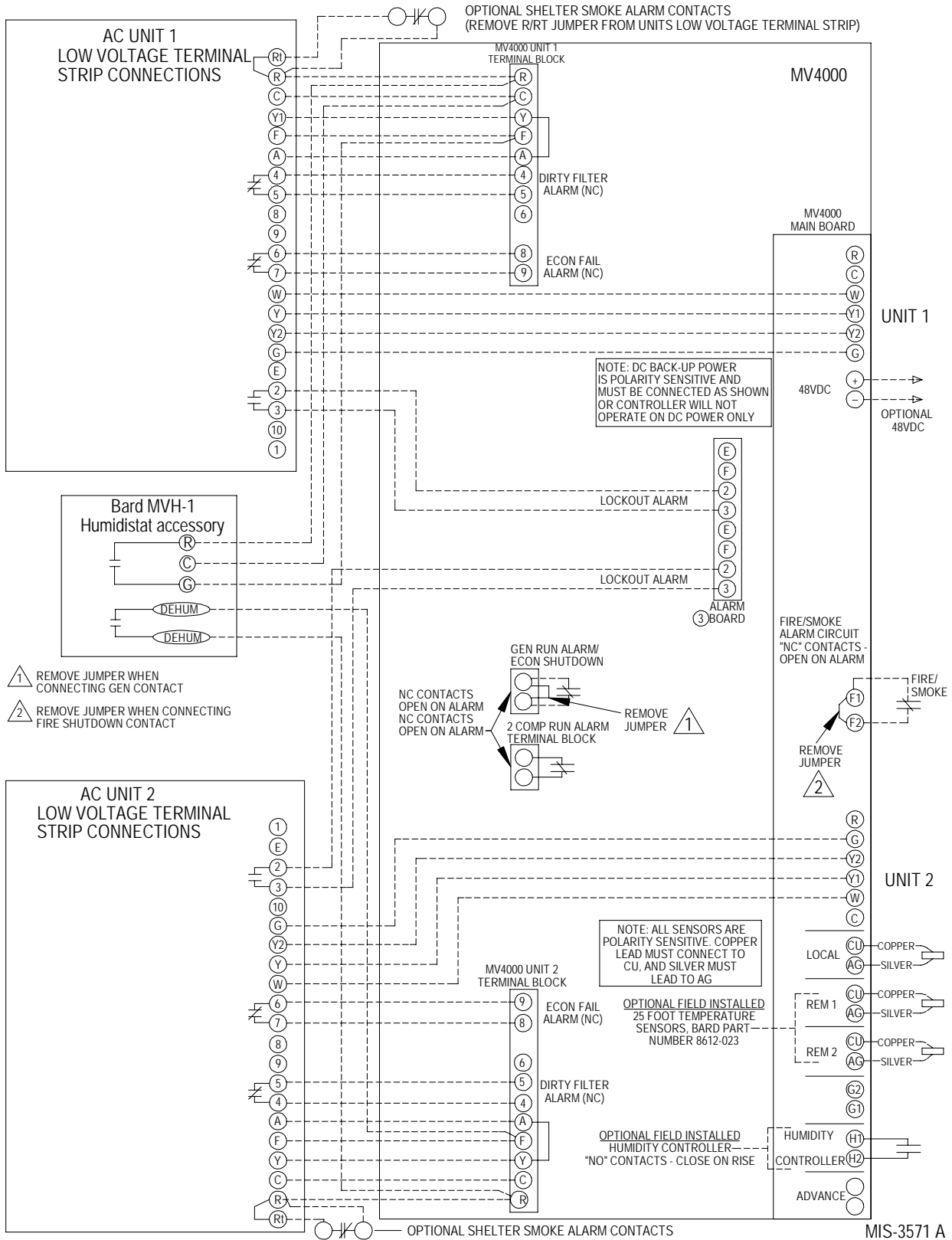

THESE UNITS REQUIRE R-410A REFRIGERANT AND POLYOL ESTER OIL.

GENERAL:

1. Use separate service equipment to avoid cross contamination of oil and refrigerants.
2. Use recovery equipment rated for R-410A refrigerant.
3. Use manifold gauges rated for R-410A (800 psi/250 psi low).
4. R-410A is a binary blend of HFC-32 and HFC-125.
5. R-410A is nearly azeotropic - similar to R-22 and R-12. Although nearly azeotropic, charge with liquid refrigerant.
6. R-410A operates at 40-70% higher pressure than R-22, and systems designed for R-22 cannot withstand this higher pressure.
7. R-410A has an ozone depletion potential of zero, but must be reclaimed due to its global warming potential.
8. R-410A compressors use Polyol Ester oil.
9. Polyol Ester oil is hygroscopic; it will rapidly absorb moisture and strongly hold this moisture in the oil.
10. A liquid line dryer must be used - even a deep vacuum will not separate moisture from the oil.
11. Limit atmospheric exposure to 15 minutes.
12. If compressor removal is necessary, always plug compressor immediately after removal. Purge with small amount of nitrogen when inserting plugs.

TOPPING OFF SYSTEM CHARGE

If a leak has occurred in the system, Bard Manufacturing recommends reclaiming, evacuating (see criteria above), and charging to the nameplate charge. If done correctly, topping off the system charge can be done without problems.

With R-410A, there are no significant changes in the refrigerant composition during multiple leaks and recharges. R-410A refrigerant is close to being an azeotropic blend (it behaves like a pure compound or single component refrigerant). The remaining refrigerant charge, in the system, may be used after leaks have occurred and then “top-off” the charge by utilizing the pressure charts on the inner control panel cover as a guideline.

REMEMBER: When adding R-410A refrigerant, it must come out of the charging cylinder/tank as a liquid to avoid any fractionation, and to insure optimal system performance. Refer to instructions for the cylinder that is being utilized for proper method of liquid extraction.



SAFETY PRACTICES:

1. Never mix R-410A with other refrigerants.
2. Use gloves and safety glasses, Polyol Ester oils can be irritating to the skin, and liquid refrigerant will freeze the skin.
3. Never use air and R-410A to leak check; the mixture may become flammable.
4. Do not inhale R-410A – the vapor attacks the nervous system, creating dizziness, loss of coordination and slurred speech. Cardiac irregularities, unconsciousness and ultimate death can result from breathing this concentration.
5. Do not burn R-410A. This decomposition produces hazardous vapors. Evacuate the area if exposed.
6. Use only cylinders rated DOT4BA/4BW 400.
7. Never fill cylinders over 80% of total capacity.
8. Store cylinders in a cool area, out of direct sunlight.
9. Never heat cylinders above 125°F.
10. Never trap liquid R-410A in manifold sets, gauge lines or cylinders. R-410A expands significantly at warmer temperatures. Once a cylinder or line is full of liquid, any further rise in temperature will cause it to burst.

START UP (Continued)

IMPORTANT INSTALLER NOTE

For improved start up performance wash the indoor coil with a dish washing detergent.

COMPRESSOR CONTROL MODULE

The compressor control module is standard on all models covered by this manual. The compressor control module is an anti-short cycle/lockout timer with high and low pressure switch monitoring and alarm relay output.

Adjustable Delay On Make And Break Timer

On initial power up or anytime power is interrupted to the unit, the *delay on make* period begins, which will be 2 minutes plus 10% of the *delay on break* setting. When the delay on make is complete and the high pressure switch and low pressure switch is closed, the compressor contactor is energized. Upon shutdown, the delay on break timer starts and prevents restart until the delay on break and delay on make periods have expired.

During routine operation of the unit with no power interruptions, the compressor will operate on demand with no delay.

High Pressure Switch and Lockout Sequence

If the high pressure switch opens, the compressor contactor will de-energize immediately. The lockout timer will go into a *soft lockout* and stay in soft lockout until the high pressure switch closes and the delay on break time has expired. If the high pressure switch opens again in this same operating cycle, the unit will go into *manual lockout* condition and the alarm relay circuit will energize. Recycling the wall thermostat resets the manual lockout.

Low Pressure Switch, Bypass, and Lockout Sequence

If the low pressure switch opens for more than 120 seconds, the compressor contactor will de-energize and go into a soft lockout. Regardless the state of the low pressure switch, the contactor will reenergize after the delay on make time delay has expired. If the low pressure switch remains open, or opens again for longer than 120 seconds, the unit will go into manual lockout condition and the alarm relay circuit will energize. Recycling the wall thermostat resets the manual lockout.

Alarm Relay Output

Alarm terminal is output connection for applications where alarm relay is employed. This terminal is powered whenever the compressor is locked out due to HPC or LPC sequences as described.

NOTE: Both high and low pressure switch controls are inherently automatic reset devices. The high pressure switch and low pressure switch cut out and cut in settings are fixed by specific air conditioner unit model. The lockout features, both soft and manual, are a function of the Compressor Control Module.

ADJUSTMENTS

Adjustable Delay on Make and Delay on Break Timer

The potentiometer is used to select Delay on Break time from 30 seconds to 5 minutes. Delay on Make (DOM) timing on power-up and after power interruptions is equal to 2 minutes plus 10% of Delay on Break (DOB) setting:

0.5 minute (30 seconds)	DOB = 123	second	DOM
1.0 minute (60 seconds)	DOB = 126	second	DOM
2.0 minute (120 seconds)	DOB = 132	second	DOM
3.0 minute (180 seconds)	DOB = 138	second	DOM
4.0 minute (240 seconds)	DOB = 144	second	DOM
5.0 minute (300 seconds)	DOB = 150	second	DOM

During routine operation of the unit with no power interruptions the compressor will operate on demand with no delay.

Typical Settings for Dual Unit Installation:

Unit 1: DOB set at 2 minutes, and DOM is 132 seconds

Unit 2: DOB set at 4 minutes, and DOM is 144 seconds

START UP (Continued)

THREE PHASE SCROLL COMPRESSOR START UP INFORMATION

Scroll compressors will only compress in one rotational direction. Direction of rotation is not an issue with single phase compressors since they will always start and run in the proper direction.

However, three phase compressors will rotate in either direction depending upon phasing of the power. Since there is a 50-50 chance of connecting power in such a way as to cause rotation in the reverse direction, verification of proper rotation must be made. Verification of proper rotation direction is made by observing that suction pressure drops and discharge pressure rises when the compressor is energized. Reverse rotation also results in an elevated sound level over that with correct rotation, as well as substantially reduced current draw compared to tabulated values.

Verification of **proper rotation** must be made at the time the equipment is put into service. If improper rotation is corrected at this time, there will be no negative impact on the durability of the compressor. However, reverse operation for over one hour may have a negative impact on the bearing due to oil pump out.

NOTE: If compressor is allowed to run in reverse rotation for several minutes, the compressor's internal protector will trip.

All three phase ZP compressors are wired identically internally. As a result, once the correct phasing is determined for a specific system or installation, connecting properly phased power leads to the same Fusite terminal should maintain proper rotation direction.

The direction of rotation of the compressor may be changed by reversing any two line connections to the unit.

PHASE MONITOR

All units with three phase scroll compressors are equipped with a 3-phase line monitor to prevent compressor damage due to phase reversal.

The phase monitor in this unit is equipped with two LEDs. If the Y signal is present at the phase monitor and phases are correct the green LED will light.

If phases are reversed, the red fault LED will be lit and compressor operation is inhibited.

If a fault condition occurs, reverse two of the supply leads to the unit. ***Do not reverse any of the unit factory wires as damage may occur.***

SERVICE HINTS

1. Caution owner/operator to maintain clean air filters at all times. Also, not to needlessly close off supply and return air registers. This reduces airflow through the system, which shortens equipment service life as well as increasing operating costs.
2. Check all power fuses or circuit breakers to be sure they are the correct rating.
3. Periodic cleaning of the outdoor coil to permit full and unrestricted airflow circulation is essential.



WARNING

Any removal of sheet metal panels from this unit exposes you to possible lacerations. Wearing gloves is highly recommended, along with proper placement of removed panels to limit others exposure to them. Never store removed panels overhead, as it creates a falling hazard!

SEQUENCE OF OPERATION

This product design allows for **Forced Emergency Ventilated Cooling** anytime “shore power” (VAC power from the utility company) is lost. The internal controls within this unit automatically recognize this, and energize the indoor blower motor, and powers the actuator to open the economizer to bring in outdoor air. The power utilized during this time is the stored battery power from the equipment shelter.

The indoor blower is powered via 52 Vdc Power 100% of the time. Contact closures/opening between the ORANGE and BLACK control signal wires trigger the motor to start and stop. The speed of the motor (airflow) is regulated by the 0-10 VDC input voltage between the “RED” and “BLACK” control wires. To control this 0-10 Vdc speed signal, potentiometers are used to reduce the triggering voltage at the various inputs needed for the specific model. Refer to Table 2 to view these varying required voltage inputs.

CALL FOR INDOOR BLOWER

On a call for the indoor blower, “G” signal is sent from the unit controller/thermostat to the unit. The “G” signal will actuate the blower relay, causing contacts to close between the “ORANGE” and “BLACK” motor control wires. This along with a 0-10 VDC motor trigger voltage input between the “RED” and “BLACK” motor control wires, will cause the motor to run. In “blower only” operation, the motor trigger voltage is identical to the economizer airflow volume. The motor trigger voltage is controlled by the Econ Potentiometer.

FIRST CALL FOR COOLING

On the first call for cooling, “G” and “Y1” signals are sent from the unit controller/thermostat to the unit. The “G” signal will actuate the indoor blower time delay relay causing a contact closure between the “ORANGE” and “BLACK” motor control wires. The “Y1” signal travels to the Economizer Logic Control, which then makes a decision to cool by either opening the outside damper, or to run the compressor based upon the indoor to outdoor DB temperature differential.

- If the indoor-to-outdoor temperature differential is great enough, the economizer logic control opens the damper actuator to provide free cooling. The economizer logic control will modulate the damper position to only allow a minimum supply air temperature of 55°F.

NOTE: *If the outdoor temperature is below 55°F, the economizer logic control outputs a signal from the energy module “IF” terminal, and sends it to the “BLOWER INTERLOCK RELAY”. This in turn energizes the PART LOAD SPEED RELAY. This causes the “ECON SPEED POTENTIOMETER” to drop out of the blower trigger voltage circuit, and replaces it with the PL Speed Potentiometer, which in turn changes the indoor blower speed (by changing the motor trigger voltage).*

- If the indoor-to-outdoor temperature differential is not great enough, the economizer logic control then forwards the “Y1” signal onto the Compressor Control Module, and the compressor and outdoor fan will start running in mechanical cooling operation. Simultaneously, the “Y1” signal travels to the PART LOAD SPEED RELAY. This causes the “ECON SPEED POTENTIOMETER” to drop out of the blower trigger voltage circuit, and replaces it with the PL Speed Potentiometer, which in turn changes the indoor blower speed (by changing the motor trigger voltage).

SECOND CALL FOR COOLING

A “Y2” signal is sent from the controller/thermostat to the economizer logic control. The Economizer Logic Control will then:

- If operating strictly on Economizer, will then start the compressor and outdoor fan by forwarding the “Y1” signal onto the Compressor Control Module, and will operate Free Cooling, along with Mechanical Cooling. At the same time, the “Y1” signal is also forwarded to the PART LOAD SPEED RELAY. This causes the “ECON SPEED POTENTIOMETER” to drop out of the blower trigger voltage circuit, and replaces it with the PL Speed Potentiometer, which in turn changes the indoor blower speed/CFM.
- If operating in mechanical cooling mode, and has been running for a minimum of 4 minutes, the Economizer Logic Control will forward the “Y2” signal onto the compressor staging solenoid (2-stage equipment only), and also onto the FULL LOAD SPEED RELAY. When this relay energizes, it causes the “PART LOAD SPEED POTENTIOMETER” to drop out of the blower trigger voltage circuit, and replaces it with the FL SPEED POTENTIOMETER, which in turn changes the indoor blower speed/CFM.

NOTE: *If installed with a lead/lag controller, and there is more than one unit, a “Y2” call may go to a second unit, prior to this one being called for. This allows for dual economizer operation prior to mechanical cooling demand being applied.*

CALL FOR HEATING

On a call for heating, “G” and “W” signals are sent from the unit controller/thermostat to the unit. The “G” signal energizes the blower relay, starting the indoor blower. The “W” signal travels through the electric heater safety limit, and if not open, then travels to the heater contactors, pulling-in the contactors, and energizing the unit strip heat.

LOSS OF UTILITY POWER

On the loss of A/C power to the unit:

- Mechanical (compressor) cooling and heating are no longer available.
- The indoor blower is forced to run on economizer airflow.
- The economizer is energized to the open (but will still modulate to a 55° supply air temperature).

Upon loss of power, all contacts on the “POWER LOSS RELAY” switch.

- This closes the auxillary contacts for the “ORANGE” and “BLACK” blower controls wires which ensures the indoor blower either starts/stays running (in economizer mode airflow)
- It also switches the economizer outdoor air temperature sensor to now only see the 15,000 ohm resistor (making economizer logic think it is 60°F outdoor temperature).
- It also causes the 48 Vdc-to-24Vdc Converter to become energized, allowing 24 Vdc power to travel to the “ECON CHANGEOVER RELAY”.
- It also allows 48 Vdc power to travel to the “ECON CHANGEOVER RELAY COIL” and causes it to switch contact closures.

With the “ECON CHANGEOVER RELAY” energized, this now switches the power feeding to the Economizer Logic Control from 24 VAC power, to 24 Vdc power, whichs allows the economizer to continue operation of the damper actuator on Vdc power. It will monitor the Supply Air Temperature sensor, and modulate the damper blade to maintain a 55°F discharge air temperature.

TROUBLESHOOTING

TROUBLESHOOTING THE 52 VDC INDOOR BLOWER MOTOR

The blower motor of the Bard “D Series” products is powered by 52 Vdc power, and is controlled with 0-10 Vdc power to determine the operating airflow. If the motor fails to run, the following steps should diagnose the problem.

TABLE 1

Motor Connection Pin Number	Color	Function	Description of Application
1	Red	SPEED INPUT	0-10 Vdc input, varying voltage input between 0-10 Vdc dictates the motor speed/CFM delivery
2	Yellow	FOUT	Not presently used
3	Blue	FAULT	Not presently used
4	Orange	RUN	Contact closure to "black" (Pin #5) with 52 VDC power on Pins #8 & #9, with 0-10 Vdc power applied to Red (Pin #1) will cause motor to run
5	Black	CONTROL GROUND	Control Ground for both start-stop function and speed control voltage
6			
7	Red	52 VDC (+)	"+" Vdc power supplied to motor
8			
9	Black	52 VDC (-)	"-" Vdc power supplied to motor

TROUBLESHOOTING THE 52 VDC INDOOR BLOWER MOTOR

1. Verify that you truly have the Vdc power correctly orientated to the unit circuit breaker. Keep in mind that most cell sites are -48 Vdc powered (meaning they are circuit breaker protecting the (-) leg of power). You can confirm this by testing with your electrical meter set to DC Volts, and ensure that with on your meter, the red wire is connected to the volts terminal, and the black wire is connected to the common terminal, that when connected to the 52 Vdc supply wires, you aren't reading -52 Vdc, but rather 52 Vdc. (IF STILL IN DOUBT, SWITCH THE FEED WIRES TO THE DC CIRCUIT BREAKER AROUND, AND SEE IF THE BLOWER WILL NOW OPERATE.)
2. Ensure you have a 52 Vdc power to the motor connector terminals. (Red wire on Pin #7 and Black wire on Pin #9).
3. Ensure you have a contact closure between the blower motor “orange” and “black” control wires by using your meter in the ohms scale to ensure continuity across these two wires.
4. Using your voltmeter (set to Volts DC) to measure across the “red” control wire on Pin #1, and the “black” control ground wire on Pin #5 to ensure you have a motor trigger voltage present. (Go to next section, if no voltage observed).
5. Shut off all power to the unit. Remove upper front service door and verify the connectors between the motor driver and the motor are connected, and have not come loose in transit, or through operational vibration.

TROUBLESHOOTING

TROUBLESHOOTING MOTOR TRIGGER VOLTAGE CIRCUIT

The motor trigger voltage circuit is controlled through a voltage divide circuit. What this means is the 52 Vdc power is being trimmed/reduced by a series of resistors and potentiometers (variable resistor) to set the motor trigger voltage to match the required unit CFM.

In the case of the Bard "D Series", the 820 ohm resistor does the majority of this voltage reduction. The three (3) different potentiometers are pulled in/out of the trigger control circuit based upon the mode of operation that the unit is operating (accomplished through the PL BLOWER RELAY and FL BLOWER RELAY) as the regulating part of the voltage reduction.

1. Connect multimeter "VOLTS LEAD" to red wire on RH side of the 820 ohm resistor (located just below DC circuit breaker). (Side of resistor terminal block that has single red wire). See Figure 9.
2. Connect multimeter "COMMON LEAD" to black lead of blower relay on Terminal #1. See Figure 9.
3. Refer to Table 2 paying attention to the present mode of operation to set the varied motor trigger voltages.

**FIGURE 9
MEASURING TRIGGER VOLTAGE**

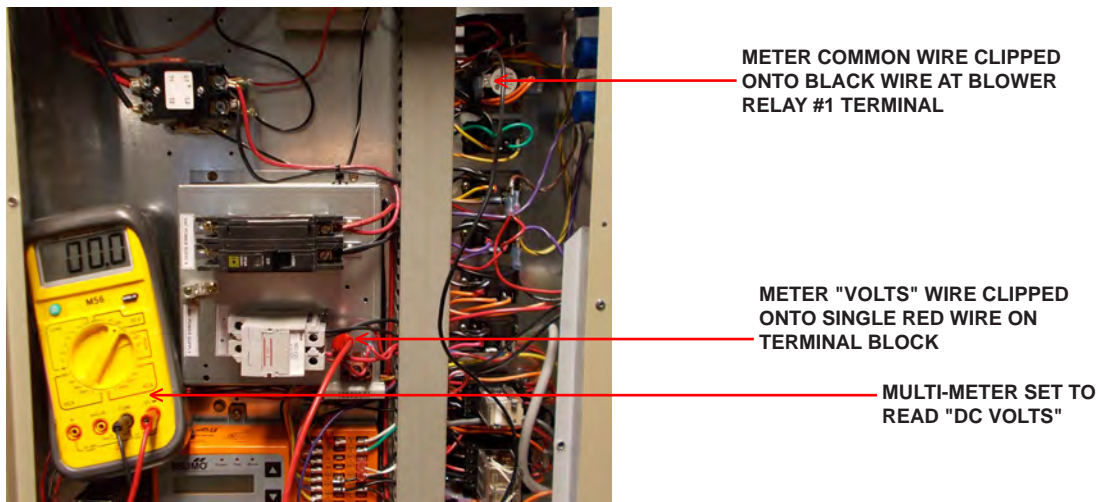

**TABLE 2
BLOWER TRIGGER VOLTAGE CHART**

Model	Blower Only	Economizer Mode (CFM / Vdc Trigger Voltage)	Economizer Mode below 40°F (CFM / Vdc Trigger Voltage)	1st Stage Cooling (CFM / Vdc Trigger Voltage)	2nd Stage Cooling (CFM / Vdc Trigger Voltage)	Electric Heat
D3SA/D3SL	Same as Economizer Mode	1800 / 8.3	800 / 2.9	800 / 2.9	1100 / 4.1	1800 / 7.6
D4SA/D4SL			1100 / 4.1	1100 / 4.1	1600 / 6.4	
D5SA/D5SL			1100 / 4.1	1100 / 4.1	1600 / 6.4	
D36A/D36L	Same as Economizer Mode	1800 / 8.3	1100 / 4.1	1100 / 4.1	1250 / 4.9	1800 / 7.6
D42A/D42L			1250 / 4.9	1250 / 4.9	1400 / 5.6	
D48A/D48L			1600 / 6.4	1600 / 6.4	1700 / 7.0	
D60A/D60L			1600 / 6.4	1600 / 6.4	1700 / 7.0	

**FIGURE 10
CONTROL LOCATIONS**

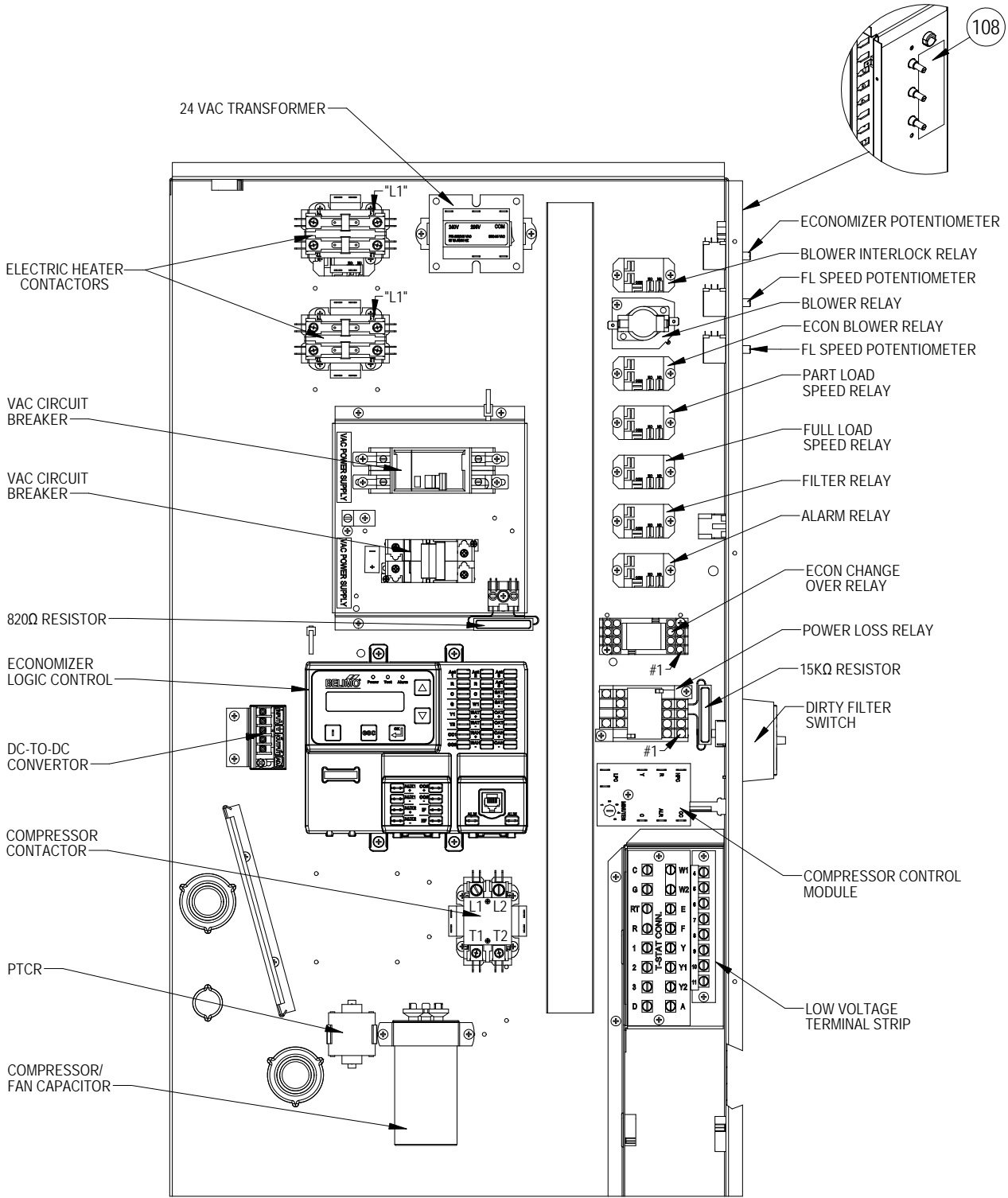

MIS-3570

ECONOMIZER TROUBLESHOOTING

Problem	Possible Cause	Action
The Economizer / Mechanical Cooling Not Operating	No input power	Using a voltmeter set to read AC voltage, verify that there is 24 VAC +/- 20% (19 VAC – 29 VAC) as measured at the “R” and “C” terminals on the Economizer Logic Control terminal strip on the base unit. If no voltage, check transformer output voltage at RTU. If 24 volts not present, check primary input power to transformer. If voltage present, check transformer circuit breaker, and check transformer for open coil. If no voltage present, check primary input power to RTU, fuses, disconnect, circuit breaker.
	Setup not complete	If the display reads “Setup Incomplete”, then not all of the required setup parameters values for minimum damper position and zip code have not been entered. Enter required information in Settings menu. See setup information in IOM manual.
	Brownout	If voltage is below 19 volts, then the Economizer Logic Control may be in Brownout Protection mode. This mode disables the compressors to protect them from low voltage operation damage. When the power is back to normal the Economizer and RTU will operate normally (see Brownout Below).
	In acceptance test or manual mode	If the Yellow LED is lighted, then the Economizer Logic Control is in a mode other than Automatic. End Mode by finding menu Item “Return to Automatic”. Refer to menu flow diagram.
There are No Characters Displayed on the Economizer Display	No input power	Using a voltmeter set to read AC voltage, verify that there is 24 VAC +/- 20% (19 VAC – 29 VAC) as measured at the “R” and “C” terminals on the Economizer Logic Control terminal strip on the base unit. If no voltage, check transformer output voltage at RTU. If 24 volts not present, check primary input power to transformer. If voltage present, check transformer circuit breaker, and check transformer for open coil. If no voltage present, check primary input power to RTU, fuses, disconnect, circuit breaker.
	Ambient temperature below display range	Below this value, the display may not be clearly visible. It should still control properly even though the display may be blank below this temperature.
The Display Shows “Brownout”	Input voltage is below 18VAC / connected load is too much for transformer	Using a voltmeter set to read AC voltage, verify that that the voltage is low. If the voltage is low check primary voltage into the RTU. If primary voltage is below the rated RTU voltage as listed on nameplate or product documentation, the primary power is in a brownout state. If voltage is within specified range, it is possible that the load on the transformer is larger than VA rating. Verify connected current, if OK, consider replacing transformer.
The Display Shows “Setup Incomplete”	The initial setup of the Economizer has not completed	The Economizer Logic Control requires parametrizing of specific settings prior to operation of the economizer or compressors. As a minimum the Vent Min Pos and ZIP Code / Postal Code need to have a value set and entered. If additional devices are attached (e.g. CO2, EF,..) then additional parametrizing is required.
	Additional devices have been added after initial setup	Some additional devices that may be added at anytime during the life of the Economizer Logic Control will require additional setup. Upon connection of these devices the economizer will notify that the device has been detected and will prompt setup. Until setup is complete, the Economizer Logic Control will function as if the devices are not there. Proceed to Settings menu and look for menu items that have a blank value, press OK and enter value. Once all values have been parametrized, the Economizer Logic Control will function as intended.
There is No Free Cooling	Display shows “OAT sensor out of range economizing is disabled”	Sensor is returning a value that is out of the predetermined range. This disables the economizer functions and outdoor air damper will return/remain at minimum position. This is a mandatory sensor and must be functional! Repair or replace. Verify sensor value by disconnection sensor leads from Economizer Logic Control and measure resistance with Ohm meter across sensor leads and compare to 10K type 2 Thermistor Table values to measured values to the value of a temperature instrument. If values are significantly different, replace sensor.
	Display shows “OAT Sensor not detected economizing is disabled”	Sensor is not present/not detected. This disables the economizer functions and damper will return/ remain at minimum position. This is a mandatory sensor and must be functional! Repair or replace. Verify sensor value by disconnection sensor leads from Economizer Logic Control and measure resistance with Ohm meter across sensor leads and compare to 10K type 2 Thermistor Table value to measured value to the value of a temperature instrument. If value is close, determine if there is any intermediate wiring. If so, check continuity. If all checks are good, attach sensor to Economizer Logic Control and see if it is detected. If not detected, try another 10k type 2 sensor. If still not detected, replace Economizer Logic Control.

ECONOMIZER TROUBLESHOOTING

Problem	Possible Cause	Action
There is No Free Cooling	Display shows "SAT sensor out of range economizing disabled"	Sensor is returning a value that is out of the predetermined range. This disables the economizer functions and outdoor air damper will return/remain at minimum position. This is a mandatory sensor and must be functional! Repair or replace. Verify sensor value by disconnecting sensor leads from Economizer Logic Control and measure resistance with Ohm meter across sensor leads and compare to 10K type 2 Thermistor Table values to measured values to the value of a temperature instrument. If values are significantly different, replace sensor.
	Display shows "SAT sensor not detected economizing disabled"	Sensor is not present/not detected. This disables the economizer functions and damper will return/remain at minimum position. This is a mandatory sensor and must be functional! Repair or replace. Verify sensor value by disconnecting sensor leads from Economizer Logic Control and measure resistance with Ohm meter across sensor leads and compare to 10K type 2 Thermistor Table value to measured value to the value of a temperature instrument. If value is close, determine if there is any intermediate wiring. If so, check continuity. If all checks are good, attach sensor to Economizer Logic Control and see if it is detected. If not detected, try another 10k type 2 sensor. If still not detected, replace Economizer Logic Control.
	The Economizer is in another operating mode	Check Status screen for current operating mode or state. Please see sequence description for more information.
A Sensor is Not Detected or Out of Range	OAT sensor	Please see troubleshooting action under Problem "There is no Free Cooling".
	SAT sensor	Please see troubleshooting action under Problem "There is no Free Cooling".
	RAT Sensor. Display shows "RAT sensor not detected operation by OAT dry bulb"	Sensor previously detected is not present. Previously configured for differential dry bulb, now economizing will be based on single OAT dry bulb. Verify sensor value by disconnection sensor leads from Economizer Logic Control and measure resistance with Ohm meter across sensor leads and compare to 10K type 2 Thermistor Table value to measured value to the value of a temperature instrument. If value is close, determine if there is any intermediate wiring. If so, check continuity. If all checks are good, attach sensor to Economizer Logic Control and see if it is detected. If not detected, try another 10k type 2 sensor. If still not detected, replace Economizer Logic Control.
	RAT Sensor. Display shows "RAT sensor not detected operation by OAH enthalpy"	Sensor previously detected is not present. Previously configured for differential enthalpy, now economizing will be based on single enthalpy. Verify sensor value by disconnecting sensor leads from Economizer Logic Control and measure resistance with Ohm meter across sensor leads and compare to 10K type 2 Thermistor Table value to measured value to the value of a temperature instrument. If value is close, determine if there is any intermediate wiring. If so, check continuity. If all checks are good, attach sensor to Economizer Logic Control and see if it is detected. If not detected, try another 10k type 2 sensor. If still not detected, replace Economizer Logic Control.
	RAT Sensor. Display shows "RAH sensor detected but RAT sensor not detected"	This configuration is not allowed. You need an RAT sensor for differential enthalpy high limit changeover. Verify that RAT sensor installed and correctly wired. Troubleshoot as above for RAT.

ECONOMIZER TROUBLESHOOTING

Problem	Possible Cause	Action
Alarm "Y2 Present Without Y1"	Potential wiring or thermostat problem	Thermostat input to Economizer Logic Control has energized Y2 (2nd stage cooling) and has not energized Y1 (1st stage cooling). This configuration is not allowed. The economizer will recognize this and will treat Y2 signal as if it is Y1 and will energize 1st stage cooling (Mechanical or Free Cooling). Check to see if wires are reversed between thermostat and economizer input. Verify continuity to see if circuit could be open or wire could be broken. Test to see thermostat 1st stage relay is closing (Y1 has 24 VAC). Make sure there are no jumpers between R and Y2.
Alarm "Heat and Cool Both Present"	Potential wiring or thermostat problem	This alarm indicates that 24 VAC is at both terminal Y1 and W1 on the Economizer Logic Control. Check for wiring problems. Note: this alarm is disabled when Heat Pump operation has been turned to On in Settings menu.
Alarm "SAT Drop for CC1 Insufficient Cooling System Problem"	Potential compressor, refrigerant, or supply fan problem	The Economizer Logic Control reads the SAT value just before energizing 1st stage mechanical cooling. After compressor has started and 4 minutes have elapsed, SAT value is again checked. If SAT has not dropped by at least 5°F then this alarm is generated. Some possibilities are: <ul style="list-style-type: none"> • Filters or coils are dirty or blocked – inspect. • SAT sensor in location where air is not mixed - perform temperature traverse. • Indoor fan is inoperable - check relay, belt, motor, bearings. • Condenser fan is inoperable - check relay, motor, head pressure control. • Compressor is faulty (internal damage) - check amperage, pressures. • Contactor energizes but compressor is out on internal/external overload. • High voltage problem to compressor -check wiring, phases, contactor. • Circuit 1 is low on refrigerant - check charge.
Alarm "SAT Drop for CC2 Insufficient Cooling System Problem"	Potential compressor, refrigerant, or supply fan problem	The Economizer Logic Control reads the SAT value just before energizing 2nd stage mechanical cooling. After compressor has started and 4 minutes have elapsed, SAT value is again checked. If SAT has not dropped by at least 5°F then this alarm is generated. Troubleshoot as above for 1st stage.
Alarm "SAT Should Be Lower"	Potential damper, linkage, or actuator problem	When in Free Cooling if the SAT is not within 10°F of the OAT, then this alarm will be generated. Exception when the damper is modulated to obtain the SAT setpoint of 55°F. Some possibilities are: <ul style="list-style-type: none"> • Check damper linkages. • Check actuator clamp / interface between damper is secure. • Check that damper blades secured to damper shaft properly. • Check that both outside air damper and return damper stroke properly. • Check that return damper closes tightly when outdoor damper is full open. • Check that OAT sensor is in the airflow path and subjected to solar radiation. • Check that SAT sensor is in a location that airflow is mixed.
Alarm "Damper Pos Value Missing"	Actuator or wiring problem	The connected actuator must have a feedback wire terminated at ACT5 on the Economizer Logic Control. The range should be between 2-10 VDC. Verify voltage with multimeter. Remove feedback wire and check voltage between terminal C and the feedback wire. If no voltage, replace actuator.
Alarm "Damper is Stuck"	Damper or linkage problem	The feedback from the actuator is used to determine the position of the damper. If the Economizer Logic Control commands the damper to drive open to a designated % and the feedback measured does not achieve the commanded value, then this alarm will be generated. <ul style="list-style-type: none"> • Check damper linkages. • Check to see if anything is in the way of damper. • Check that actuator limit stop not adjusted to smaller angle.
	Damper rotation below what is allowed	If the damper rotation is less than 85% (77°) and the Economizer Test has not been run to scale the output to the damper travel, this alarm may occur.
Alarm "Compressor 1 Not Detected"	CC1 output circuit is open	When the Economizer Logic Control is first powered, it detects the presence of the compressor control circuit. If the circuit is detected as open, this alarm will be generated. Check all wiring, connectors, and devices in series between CC1 and contactor coil.
Alarm "Compressor 2 Not Detected"		

ECONOMIZER TROUBLESHOOTING

Problem	Possible Cause	Action
Alarm "Compressor 1 Not Detected"	Compressor safety open	<ul style="list-style-type: none"> • Check Low Pressure control. • Check High Pressure control. • Check Compressor Current protector.
	Compressor contactor coil bad	Check that there is resistance through the coil and compare to min requirements in technical document.
Alarm "Compressor 2 Not Detected"	Inability to auto detect	If all items above have been verified good and circuit continuous, then in Settings menu under Devices 1, change Compressor Qty from Auto to 1 or 2 to match number of compressors in the RTU. Once the Qty selected, the alarm will clear, the user must verify the compressor does enable when it is supposed to.
	Potential damper, linkage, actuator problem, or wiring problem	In order for the Economizer Logic Control to enter into Integrated Cooling mode, the damper must be close to full open (> 85%) and Y2 must be enabled. See sequence of operation for more information. Check damper and linkage components as addressed above. Check Y2 signal.
There is No Integrated Cooling	Damper rotation not scaled	If the damper rotation is less than 85% (77°) and the Economizer Test has not been run to scale the output to the damper travel, then Integrated cooling will not ever occur.
	SAT Y2 limit	If the SAT Y2 Limit is on in Settings menu, then Integrated Cooling will be disabled when SAT is below the specified temperature. See sequence of operation for more information.
	In time delay	There is a time delay after the damper reaches open till 2nd stage Integrated Cooling can occur. See sequence of operation for more information.
	Economizer Logic Control cannot detect the Energy Module, which was previously detected as installed	<p>The following functions (if they were utilized) will be disabled:</p> <ul style="list-style-type: none"> • Purge. • Remote damper override potentiometer. • CO2 sensing and Demand Control Ventilation. • Low Speed indoor fan control. <p>Full unplug per mounting instructions. Check plug and socket for any debris. Clean carefully if necessary. Re-install Energy Module per IOM manual instructions until you hear a snap indicating it is locked into place. If this does not resolve problem, replace Economizer Logic Control.</p>
Alarm "2 Speed Fan Not Detected"	Energy Module not detected	Check that the Energy Module is Connected in the "Present Devices" menu. If not troubleshoot as above.
	Wiring or indoor fan relay problem	When the Economizer Logic Control is first powered, it detects the presence of the Indoor Fan control circuit. If the circuit is detected as open, this alarm will be generated. Check all wiring, connectors, and relay coil. Check that there is resistance through the coil and compare to min requirements in technical document.
	Inability to auto detect	If the two potential problems above have been verified, then there may be a problem with auto detecting. In "Settings" menu under Devices 1, verify the set value is Auto or Available. If set on Auto try setting value to Available. Once set to Available, the alarm will clear, the user must verify proper operation of IF output.

CHECKING ECONOMIZER TEMPERATURE SENSORS

1. Disconnect temperature sensor economizer logic control.
2. With sensor in known ambient temperature, use an ohmmeter and measure the resistance of the sensor. Also use ohmmeter to check for short or open.
3. Check resistance reading to chart of resistance. Use sensor ambient temperature. (Tolerance of part is $\pm 10\%$.)
4. If sensor resistance reads very low, then sensor is shorted and will not allow proper operation.
5. If sensor is out of tolerance, shorted, open or reads very low ohms then it should be replaced.

TEMPERATURE F VS. RESISTANCE R OF TEMPERATURE SENSOR

F	R	F	R	F	R	F	R
-25.0	196871	13.0	56985	53.0	19374	89.0	7507
-24.0	190099	14.0	55284	52.0	18867	90.0	7334
-23.0	183585	15.0	53640	53.0	18375	91.0	7165
-22.0	177318	16.0	52051	54.0	17989	92.0	7000
-21.0	171289	17.0	50514	55.0	17434	93.0	6840
-20.0	165487	18.0	49028	56.0	16984	94.0	6683
-19.0	159904	19.0	47590	57.0	16547	95.0	6531
-18.0	154529	20.0	46200	58.0	16122	96.0	6383
-17.0	149355	21.0	44855	59.0	15710	97.0	6239
-16.0	144374	22.0	43554	60.0	15310	98.0	6098
-15.0	139576	23.0	42295	61.0	14921	99.0	5961
-14.0	134956	24.0	41077	62.0	14544	100.0	5827
-13.0	130506	25.0	39898	63.0	14177	101.0	5697
-12.0	126219	26.0	38757	64.0	13820	102.0	5570
-11.0	122089	27.0	37652	65.0	13474	103.0	5446
-10.0	118108	28.0	36583	66.0	13137	104.0	5326
-9.0	114272	29.0	35548	67.0	12810	105.0	5208
-8.0	110575	30.0	34545	68.0	12492	106.0	5094
-7.0	107010	31.0	33574	69.0	12183	107.0	4982
-6.0	103574	32.0	32634	70.0	11883	108.0	4873
-5.0	100260	33.0	31723	71.0	11591	109.0	4767
-4.0	97064	34.0	30840	72.0	11307	110.0	4663
-3.0	93981	35.0	29986	73.0	11031	111.0	4562
-2.0	91008	36.0	29157	74.0	10762	112.0	4464
-1.0	88139	37.0	28355	75.0	10501	113.0	4367
0.0	85371	38.0	27577	76.0	10247	114.0	4274
1.0	82699	39.0	26823	77.0	10000	115.0	4182
2.0	80121	40.0	26092	78.0	9760	116.0	4093
3.0	77632	41.0	25383	79.0	9526	117.0	4006
4.0	75230	42.0	24696	80.0	9299	118.0	3921
5.0	72910	43.0	24030	81.0	9077	119.0	3838
6.0	70670	44.0	23384	82.0	8862	120.0	3757
7.0	68507	45.0	22758	83.0	8653	121.0	3678
8.0	66418	46.0	22150	84.0	8449	122.0	3601
9.0	64399	47.0	21561	85.0	8250	123.0	3526
10.0	62449	48.0	20989	86.0	8057	124.0	3452
11.0	60565	49.0	20435	87.0	7869		
12.0	58745	50.0	19896	88.0	7686		

TROUBLESHOOTING

FAN BLADE SETTING DIMENSIONS

Shown in Figure 11 is the correct fan blade setting for proper air delivery across the outdoor coil. Refer to Table 3 for unit specific dimension.

Any service work requiring removal or adjustment in the fan and/or motor area will require that the dimensions below be checked and blade adjusted in or out on the motor shaft accordingly.

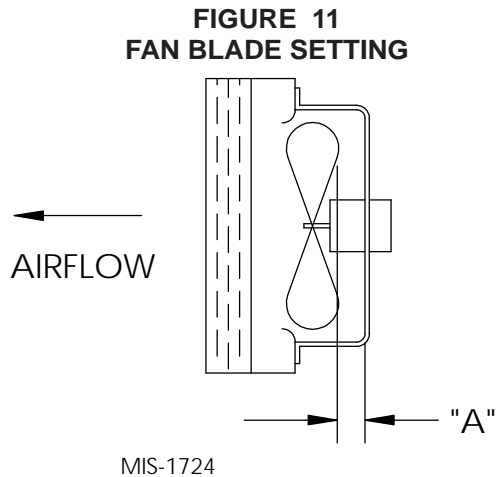

TABLE 3
FAN BLADE DIMENSION

Model	Dimension A
All Covered by this Manual	1.75"

REMOVAL OF FAN SHROUD

1. Disconnect all power to the unit.
2. Remove the screws holding both grilles, one on each side of unit, and remove grilles.
3. Remove screws holding fan shroud to condenser and bottom. Nine (9) screws.
4. Unwire condenser fan motor.
5. Slide complete motor, fan blade, and shroud assembly out the left side of the unit.
6. Service motor/fan as needed.
7. Reverse steps to reinstall.

R-410A REFRIGERANT CHARGE

This unit was charged at the factory with the quantity of refrigerant listed on the serial plate. AHRI capacity and efficiency ratings were determined by testing with this refrigerant charge quantity.

The following pressure tables show nominal pressures for the units. Since many installation specific situations can affect the pressure readings, this information should only be used by certified technicians as a guide for evaluating proper system performance. They shall not be used to adjust charge. If charge is in doubt, reclaim, evacuate and recharge the unit to the serial plate charge.

TABLE 4A
AIR TEMPERATURE ENTERING OUTDOOR COIL, DEGREE °F

Model	Return Air Temperature	Pressure	75	80	85	90	95	100	105	110	115	120	Capacitors	
													Part No.	Ratings
D36A	75° DB 62° WB	Low Side High Side	133 313	135 327	137 342	138 361	139 382	141 406	143 432	145 461	147 492	149 527	8552-079	1 Ø, 240V 45+10/370
	80° DB 67° WB	Low Side High Side	142 321	144 335	146 351	148 370	149 392	151 416	153 443	155 473	157 505	159 540	8552-005	3 Ø, 240V 10/370
	85° DB 72° WB	Low Side High Side	147 332	149 347	151 363	153 383	154 406	156 431	158 459	160 490	162 523	165 559	8552-091	3 Ø, 460V 15/370
D42A	75° DB 62° WB	Low Side High Side	131 315	132 331	134 348	136 368	137 388	139 410	142 435	144 461	146 489	149 520	8552-079	1 Ø, 240V 45+10/370
	80° DB 67° WB	Low Side High Side	140 323	141 339	143 357	145 377	147 398	149 421	152 446	154 473	156 502	159 533	8552-005	3 Ø, 240V 10/370
	85° DB 72° WB	Low Side High Side	145 334	146 351	148 369	150 390	152 412	154 436	157 462	159 490	161 520	165 552	8552-091	3 Ø, 460V 15/370
D48A	75° DB 62° WB	Low Side High Side	133 325	136 341	137 360	139 379	141 401	142 424	144 449	145 477	147 505	148 535	8552-089	1 Ø, 240V 70+10/370
	80° DB 67° WB	Low Side High Side	142 333	145 350	147 369	149 389	151 411	152 435	154 461	155 489	157 518	158 549	8552-005	3 Ø, 240V 10/370
	85° DB 72° WB	Low Side High Side	147 345	150 362	152 382	154 403	156 425	157 450	159 477	160 506	162 536	164 568	8552-091	3 Ø, 460V 15/370
D60A	75° DB 62° WB	Low Side High Side	129 353	130 362	132 374	133 390	134 410	136 432	137 458	137 488	139 522	140 559	8552-058	1 Ø, 240V 80+10/440
	80° DB 67° WB	Low Side High Side	138 362	139 371	141 384	142 400	143 420	145 443	146 470	147 501	149 535	150 573	8552-005	3 Ø, 240V 10/370
	85° DB 72° WB	Low Side High Side	143 375	144 384	146 397	147 414	148 435	150 459	151 486	152 519	154 554	155 593	8552-091	3 Ø, 460V 15/370

7961-791

TABLE 4B
AIR TEMPERATURE ENTERING OUTDOOR COIL, DEGREE °F

Model	Return Air Temperature	Pressure	75	80	85	90	95	100	105	110	115	120	Capacitors	
													Part No.	Ratings
D3SA	75° DB 62° WB	Low Side High Side	134 311	135 329	136 347	137 369	138 391	139 414	141 441	142 468	144 497	146 528	8552-079	1 Ø, 240V 45+10/370
	80° DB 67° WB	Low Side High Side	143 319	144 337	145 356	147 378	148 401	149 425	151 452	152 480	154 510	156 542	8552-005	3 Ø, 240V 10/370
	85° DB 72° WB	Low Side High Side	148 330	149 349	150 368	152 391	153 415	154 440	156 468	157 497	159 528	161 561	8552-091	3 Ø, 460V 15/370
D4SA	75° DB 62° WB	Low Side High Side	137 326	138 339	139 356	140 375	141 398	143 423	144 450	146 482	148 515	150 551	8552-094	1 Ø, 240V 30+10/370
	80° DB 67° WB	Low Side High Side	147 334	148 348	149 365	150 385	151 408	153 343	154 462	156 494	158 528	160 565	8552-005	3 Ø, 240V 10/370
	85° DB 72° WB	Low Side High Side	152 346	153 360	154 378	155 398	156 422	158 449	159 478	161 511	164 546	166 585	8552-091	3 Ø, 460V 15/370
D5SA	75° DB 62° WB	Low Side High Side	130 339	131 352	132 368	133 387	135 410	136 437	137 467	139 500	141 537	143 577	8552-080	1 Ø, 240V 40+10/370
	80° DB 67° WB	Low Side High Side	139 348	140 361	141 377	142 397	144 421	145 448	147 479	149 513	151 551	153 592	8552-005	3 Ø, 240V 10/370
	85° DB 72° WB	Low Side High Side	144 360	145 374	146 390	147 411	149 436	150 464	152 496	154 531	156 570	158 613	8552-091	3 Ø, 460V 15/370

7961-792

TABLE 5A

Model	Rated Volts, Hertz & Phase	AC POWER CIRCUIT				DC POWER CIRCUIT			
		Minimum Circuit Ampacity	Maximum External Fuse or Ckt. Breaker	Field Power Wire Size	Ground Wire	Minimum Circuit Ampacity	Maximum External Fuse or Ckt. Breaker	Field Power Wire Size	Ground Wire
D3SA-A05 / D3SL2-A05 D3SA-A10 / D3SL2-A10	208/230-60-1	26 52	40 50	8 8	10 10	17.5 17.5	20 20	12 12	16 16
D3SA-B06 / D3SL2-B06 D3SA-B09 / D3SL2-B09	208/230-60-3	18 27.1	30 30	10 10	12 12	17.5 17.5	20 20	12 12	16 16
D3SA-C06 / D3SL2-C06 D3SA-C09 / D3SL2-C09	460-60-3	9 13.5	10 15	14 14	14 14	17.5 17.5	20 20	12 12	16 16
D4SA-A05 / D4SL2-A05 D4SA-A10 / D4SL2-A10	208/230-60-1	28.2 52	45 60	8 6	10 10	17.5 17.5	20 20	12 12	16 16
D4SA-B06 / D4SL2-B06 D4SA-B09 / D4SL2-B09	208/230-60-3	19.2 27.1	30 30	10 10	10 10	17.5 17.5	20 20	12 12	16 16
D4SA-C06 / D4SL2-C06 D4SA-C09 / D4SL2-C09	460-60-3	9 13.5	15 15	14 14	14 14	17.5 17.5	20 20	12 12	16 16
D5SA-A05 / D5SL2-A05 D5SA-A10 / D5SL2-A10	208/230-60-1	35.6 52	60 60	6 6	10 10	17.5 17.5	20 20	12 12	16 16
D5SA-B06 / D5SL2-B06 D5SA-B09 / D5SL2-B09	208/230-60-3	20.6 27.1	35 35	8 8	10 10	17.5 17.5	20 20	12 12	16 16
D5SA-C06 / D5SL2-C06 D5SA-C09 / D5SL2-C09	460-60-3	10 13.5	15 15	14 14	14 14	17.5 17.5	20 20	12 12	16 16

TABLE 5B

Model	Rated Volts, Hertz & Phase	AC POWER CIRCUIT				DC POWER CIRCUIT			
		Minimum Circuit Ampacity	Maximum External Fuse or Ckt. Breaker	Field Power Wire Size	Ground Wire	Minimum Circuit Ampacity	Maximum External Fuse or Ckt. Breaker	Field Power Wire Size	Ground Wire
D36A-A05 / D36L2-A05 D36A-A10 / D36L2-A10	208/230-60-1	26 52	45 60	8 6	10 10	17.5 17.5	20 20	12 12	16 16
D36A-B06 / D36L2-B06 D36A-B09 / D36L2-B09	208/230-60-3	18 27.1	25 30	10 10	10 10	17.5 17.5	20 20	12 12	16 16
D36A-C06 / D36L2-C06 D36A-C09 / D36L2-C09	460-60-3	9 13.5	10 15	14 14	14 14	17.5 17.5	20 20	12 12	16 16
D42A-A05 / D42L2-A05 D42A-A10 / D42L2-A10	208/230-60-1	26 52	40 60	8 6	10 10	17.5 17.5	20 20	12 12	16 16
D42A-B06 / D42L2-B06 D42A-B09 / D42L2-B09	208/230-60-3	18.6 27.1	30 30	10 10	10 10	17.5 17.5	20 20	12 12	16 16
D42A-C06 / D42L2-C06 D42A-C09 / D42L2-C09	460-60-3	9 13.5	15 15	14 14	14 14	17.5 17.5	20 20	12 12	16 16
D48A-A05 / D48L2-A05 D48A-A10 / D48L2-A10	208/230-60-1	29 52	50 50	8 8	10 10	17.5 17.5	20 20	12 12	16 16
D48A-B06 / D48L2-B06 D48A-B09 / D48L2-B09	208/230-60-3	18.8 27.1	30 30	10 10	10 10	17.5 17.5	20 20	12 12	16 16
D48A-C06 / D48L2-C06 D48A-C09 / D48L2-C09	460-60-3	9 13.5	15 15	14 14	14 14	17.5 17.5	20 20	12 12	16 16
D60A-A05 / D60L2-A05 D60A-A10 / D60L2-A10	208/230-60-1	34.4 52	60 60	6 6	10 10	17.5 17.5	20 20	12 12	16 16
D60A-B06 / D60L2-B06 D60A-B09 / D60L2-B09	208/230-60-3	27.5 27.5	35 35	8 8	10 10	17.5 17.5	20 20	12 12	16 16
D60A-C06 / D60L2-C06 D60A-C09 / D60L2-C09	460-60-3	10.8 13.5	15 15	14 14	14 14	17.5 17.5	20 20	12 12	16 16

These "Minimum Circuit Ampacity" values are to be used for sizing the field power conductors. Refer to the National Electric Code (latest version), Article 310 for power conductor sizing.

CAUTION: When more than one field power circuit is run through one conduit, the conductors must be derated. Pay special attention to note 8 of Table 310 regarding Ampacity Adjustment Factors when more than three (3) current carrying conductors are in a raceway.

Maximum Size of the time delay fuse or HVAC type circuit breaker for protection of field wiring conductors.
Based on 75°C copper wire. All wiring must conform to the National Electric Code and all local codes.

**TABLE 6
INDOOR BLOWER PERFORMANCE**

MODEL	RATED ESP	MAX ESP	ECONOMIZER CFM ABOVE 40°	① ECONOMIZER CFM BELOW 40°	RATED PART LOAD COOLING CFM	② RATED FULL LOAD COOLING CFM	ELECTRIC HEAT AIRFLOW
D3SA/D3SL	0.15	0.50	1800	800	800	1100	1800
D4SA/D4SL	0.15	0.50	1800	1100	1100	1600	1800
D5SA/D5SL	0.20	0.50	1800	1100	1100	1600	1800
D36A/D36L	0.15	0.50	1800	1100	1100	1250	1800
D42A/D42L	0.20	0.50	1800	1250	1250	1400	1800
D48A/D48L	0.20	0.50	1800	1600	1600	1700	1800
D60A/D60L	0.20	0.50	1800	1600	1600	1700	1800

① Economizer Logic Control derives at this decision point, and switches the indoor motor speed. The damper actuator will then adjust to still yield a 55°F supply air temperature.

② On single-stage models, this only occurs if you have a thermostat/controller with "Y2" cooling stage connected.