

---

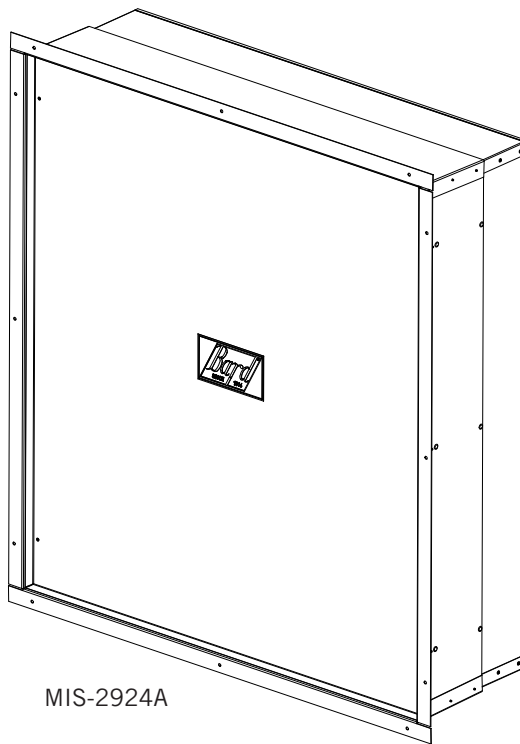
# INSTALLATION INSTRUCTIONS

---

## I-TEC<sup>®</sup> Wall Sleeve for 4" and 8" Louvers

Models:

IWS-A8H    IWS-B8H    IWS-C8H



MIS-2924A



*Climate Control Solutions*

Bard Manufacturing Company, Inc.  
Bryan, Ohio 43506  
[www.bardhvac.com](http://www.bardhvac.com)

Manual:        2100-626E  
Supersedes:   2100-626D  
Date:            8-14-23

# CONTENTS

---

<b>General Information .....</b>	<b>2</b>
Shipping Damage .....	2
General.....	2
Unpacking .....	4
Optional Louver Angles.....	4
<b>Installation .....</b>	<b>6</b>
Installation – Wood Framed Walls.....	6
Installation – Masonry Construction Walls.....	7
Attachment of Wall Sleeve to I-TEC Unit.....	8

## Getting Other Information and Publications

The following publications can help when installing the wall sleeve. They can usually be found at the local library or purchased directly from the publisher. Be sure to consult the current edition of each standard.

Standard for the Installation of Air Conditioning and Ventilating Systems.....ANSI/NFPA 90A

Standard for Warm Air Heating and Air Conditioning Systems .....ANSI/NFPA 90B

In addition, it may be helpful to consult the latest revision of I-TEC Installation Instructions manual 2100-549.

<b>Replacement Parts .....</b>	<b>10</b>
--------------------------------	-----------

## Figures and Table

Figure 1 IWS-**H Wall Sleeve Dimensions .....	4
Figure 2 I-TEC and Wall Sleeve .....	5
Figure 3 Optional Louver Angles.....	5
Figure 4 Wood Framed Installation .....	6
Figure 5 Application of Sealant to Flanges .....	7
Figure 6 Masonry Construction Installation.....	7
Figure 7 Typical Installation.....	8
Figure 8 Attachment of Wall Sleeve .....	9

For more information, contact these publishers:

**ACCA      Air Conditioning Contractors of America**  
1712 New Hampshire Ave. N.W.  
Washington, DC 20009  
Telephone: (202) 483-9370  
Fax: (202) 234-4721

**ANSI      American National Standards Institute**  
11 West Street, 13th Floor  
New York, NY 10036  
Telephone: (212) 642-4900  
Fax: (212) 302-1286

**ASHRAE    American Society of Heating, Refrigeration  
and Air Conditioning Engineers, Inc.**  
1791 Tullie Circle, N.E.  
Atlanta, GA 30329-2305  
Telephone: (404) 636-8400  
Fax: (404) 321-5478

**NFPA      National Fire Protection Association**  
Batterymarch Park  
P.O. Box 9101  
Quincy, MA 02269-9901  
Telephone: (800) 344-3555  
Fax: (617) 984-7057

---

## GENERAL INFORMATION

### Shipping Damage

Upon receipt of equipment, the carton should be checked for external signs of shipping damage. If damage is found, the receiving party must contact the last carrier immediately, preferably in writing, requesting inspection by the carrier's agent.

### General

The IWS-\*\*H Series Wall Sleeve is designed for use with I-TEC Series heat pumps and air conditioners. The wall sleeve assembly consists of a large intake sleeve and a smaller exhaust sleeve. Both sleeves are telescoping to adjust for different wall depths (see Figure 1 on page 4 and Figure 2 on page 5). The IWS-\*\*H Series Wall Sleeves are designed to be used with

4" or 8" louvers (see Table 1). A louver is not included with the IWS-\*\*H Wall Sleeve.

The equipment covered in this manual is to be installed by trained service and installation technicians. These instructions explain the recommended method to install the wall sleeve. These instructions and any instructions packaged with any separate equipment required to make the entire air conditioning system should be carefully read before beginning the installation.

While these instructions are intended as a general recommended guide, they do not supersede any national and/or local codes in any way. Authorities having jurisdiction should be consulted before the installation is made.

**TABLE 1**  
**IWS-\*\*H Wall Sleeve Application Chart**

Wall Sleeve Model No.	Louver Depth (inches)	Wall Depth (inches)	Sleeve Depth Setting (inches)	Distance Unit Extends Into Room (inches)
IWS-A8H	4	4 <sup>1</sup>	8	4 <sup>2</sup>
IWS-A8H	4	5 <sup>1</sup>	8	3 <sup>2</sup>
IWS-A8H	4	6 <sup>1</sup>	8	2 <sup>2</sup>
IWS-A8H	4	7 <sup>1</sup>	8	1 <sup>2</sup>
IWS-A8H	4	8 <sup>1</sup>	8	0
IWS-A8H	4	9	9	0
IWS-A8H	4	10	10	0
IWS-A8H	4	11	11	0
IWS-A8H	4	12	12	0
IWS-A8H	8	4	12	8
IWS-A8H	8	5	12	7
IWS-A8H	8	6	12	6
IWS-A8H	8	7	12	5
IWS-A8H	8	8	12	4 <sup>2</sup>
IWS-A8H	8	9	12	3 <sup>2</sup>
IWS-A8H	8	10	12	2 <sup>2</sup>
IWS-A8H	8	11	12	1 <sup>2</sup>
IWS-A8H	8	12	12	0
IWS-B8H	4	12	12	0
IWS-B8H	4	13	13	0
IWS-B8H	4	14	14	0
IWS-B8H	4	15	15	0
IWS-B8H	4	16	16	0
IWS-B8H	4	17	17	0
IWS-B8H	4	18	18	0
IWS-B8H	4	19	19	0
IWS-B8H	4	20	20	0
IWS-B8H	8	12	12	0
IWS-B8H	8	13	13	0
IWS-B8H	8	14	14	0
IWS-B8H	8	15	15	0
IWS-C8H	8	15	15	0
IWS-C8H	8	16	16	0
IWS-C8H	8	17	17	0
IWS-C8H	8	18	18	0
IWS-C8H	8	19	19	0
IWS-C8H	8	20	20	0

<sup>1</sup> Refer to louver manufacturer's installation requirements for minimum structural wall thickness.

<sup>2</sup> IST4 Side Trim Kit available to fill gap between unit and wall.

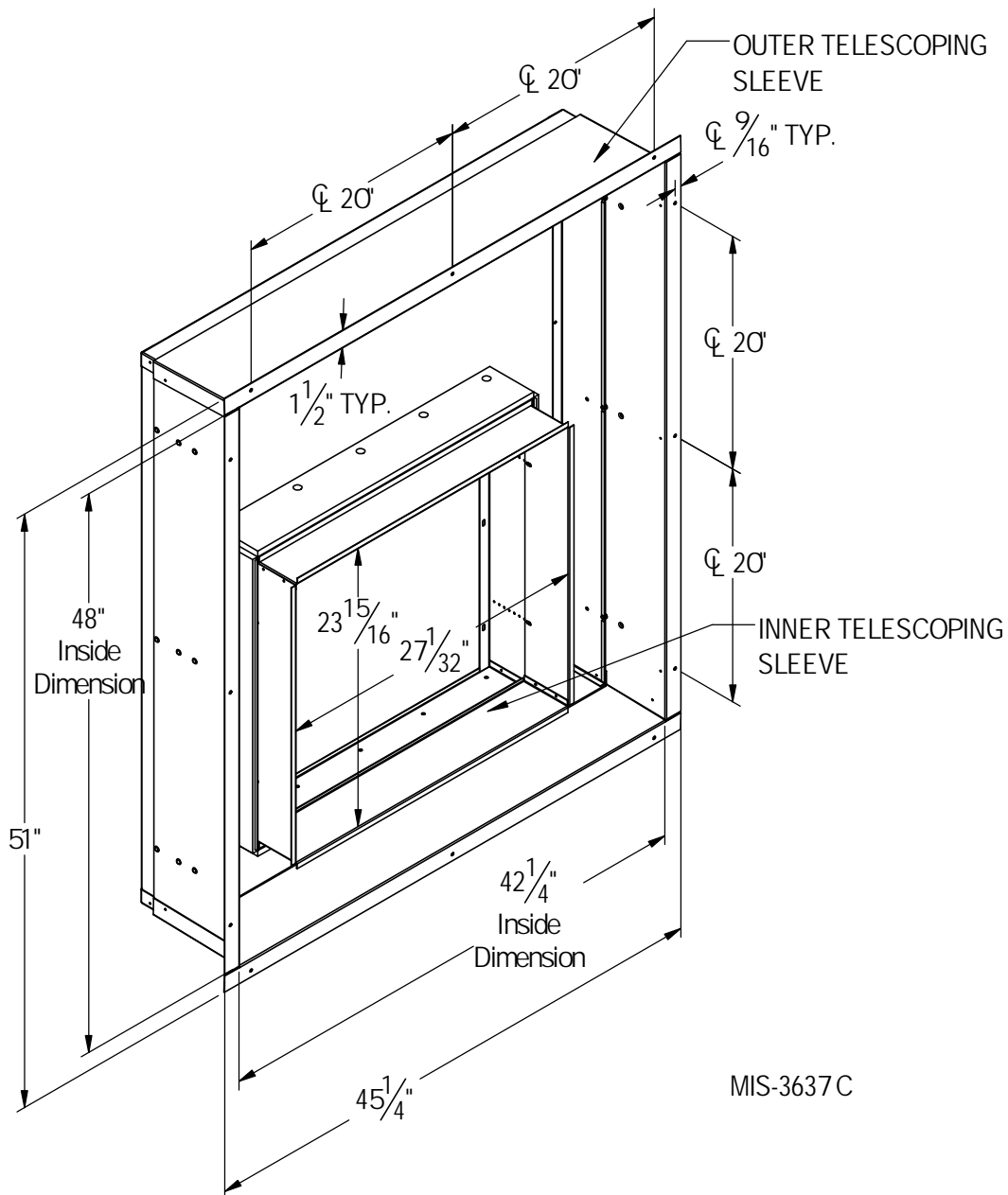
## Unpacking

1. The IWS-\*\*H Series Wall Sleeve is shipped with a weatherization/security plate. The smaller exhaust sleeve is attached to the weatherization/security plate with two (2) screws. Remove and discard these screws and set the exhaust sleeve assembly aside.
2. Remove the inner telescoping sleeve (with the rubber gasket) from larger intake sleeve and set it aside.
3. Remove intake sleeve, with weatherization/security plate attached, from the carton and turn over.
4. Remove the six (6) screws attaching the weatherization/security plate.

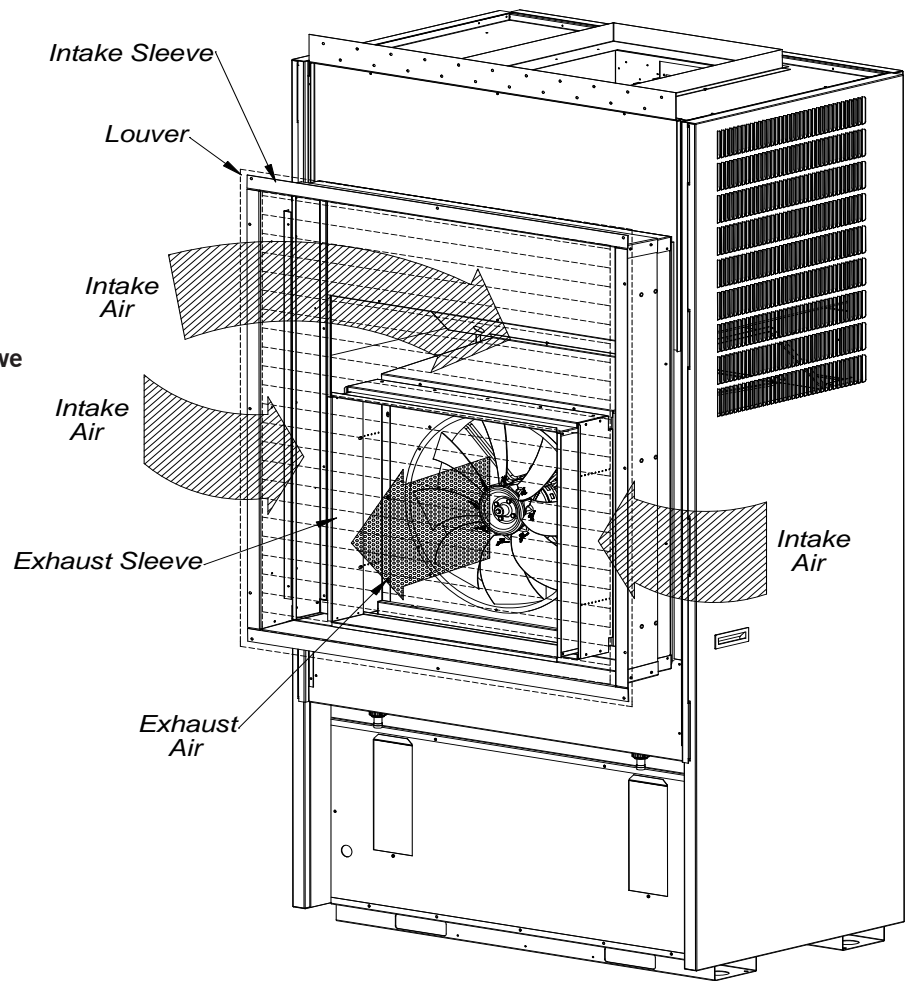
## Optional Louver Angles

Optional louver angles are supplied for use with the ILST 4" Storm Louver. Refer to Figure 3 for installation instructions.

**FIGURE 1**  
**IWS-\*\*H Wall Sleeve Dimensions**

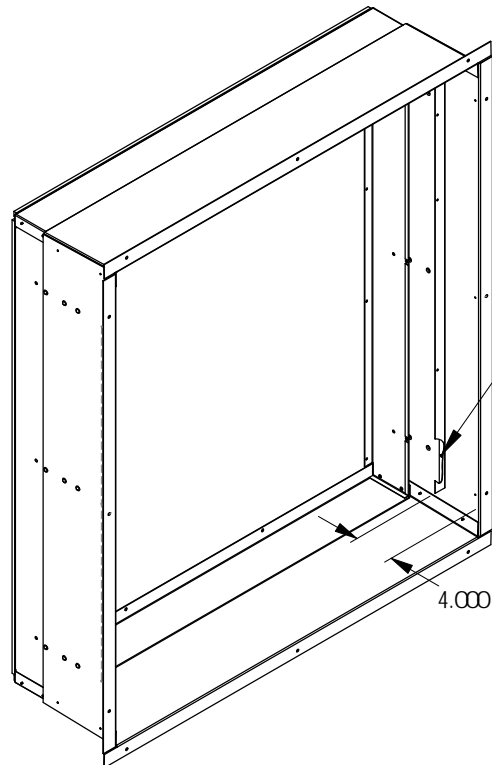


**FIGURE 2**  
I-TEC and Wall Sleeve



MIS-2981 B

**FIGURE 3**  
Optional Louver Angles



MIS-3673

# INSTALLATION

## Installation – Wood Framed Walls

For wood frame construction walls, the minimum dimensions of the opening must be 48-1/4" inches tall by 42-3/4" inches wide. A 2 x 6 header will be required for the opening. The sides of the opening must have trimmer studs to support the header and to provide a structural member on which to fasten the sleeve (see Figure 4). All of the dimensions are referenced from the finished floor height. If a riser platform accessory is used, adjust dimensions accordingly.

Once the opening is framed, the sheeting can be installed. The sheeting material must not extend into the opening.

The intake sleeve should be test fit into the opening to make sure of the dimensions. The sleeve must be inserted into the opening from the outside of the building. The bottom of the sleeve must be level from side to side, and the sleeve must be square in the opening. A slope is built into the bottom of the sleeve from the inside to the outside. This will allow any water that gets into the sleeve to drain out. Once the test fit is completed, the sleeve must be removed from the opening, and two 1/4" beads of sealant must be applied to the mounting flanges of the sleeve (see Figure 5).

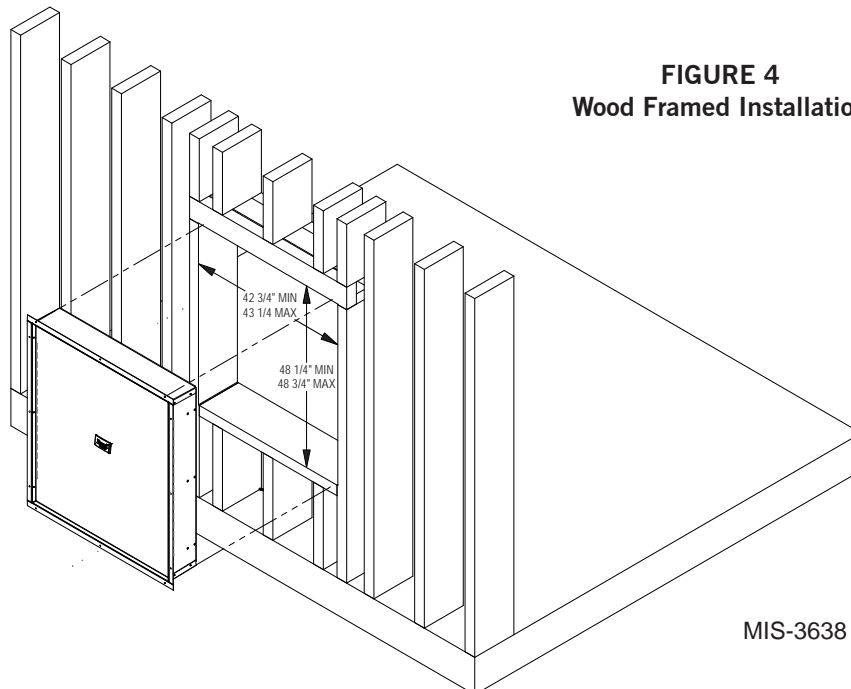
The sleeve is then reinserted into the prepared opening from the outside of the building. All of the mounting flanges must contact the exterior wall. Check to see that there is enough sealant to make this joint watertight. Additional sealant must be applied as necessary. The

sleeve must be centered in the opening, and the bottom of the sleeve must be checked to make certain that it is level from side to side. The bottom flange should be secured to the wall by using two (2) field-supplied wood screws through the holes in the bottom mounting flange of the sleeve. The sleeve must be checked to make sure that it is square in the opening. Once the sleeve is square, the side and top mounting flanges of the sleeve must be secured to the wall with ten (10) field-supplied wood screws through the holes in the flanges.

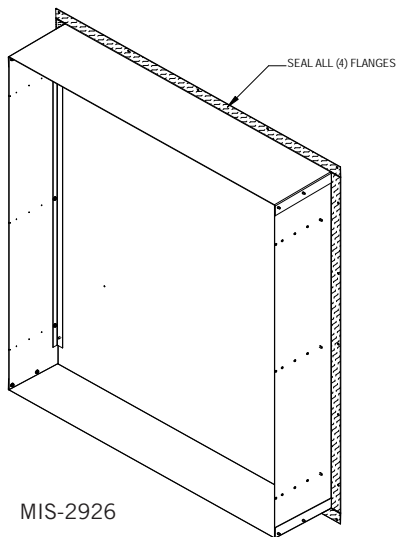
The inner portion of the intake sleeve must be inserted from the inside of the building. While holding the flanged side of the sleeve, slide it into the outer sleeve and insert far enough so it projects approximately 1/2" from either the smooth wall surface or from the sill. Final adjustment must be done from the outside.

On the inside of the building, the gaps between the sleeve and the rough wall opening must be filled with insulation.

**NOTE:** If foamed insulation is used, the final location of the inner sleeve must be determined since the foam insulation could lock the inner sleeve into an incorrect location causing either an air leak between sleeve and back of unit or preventing the unit from going as tight to the wall or sill as desired. This must be done before the unit is placed and before the inner portion of the intake sleeve is secured with screws to the outer sleeve. Insulating this space will prevent infiltration of any unwanted outside air (see Figure 7 on page 8).



**FIGURE 5**  
Application of Sealant to Flanges



If the I-TEC unit will be drained through the wall, the drain line must be installed prior to setting the unit. Information for the drain installation is provided in the installation instructions supplied with the unit. At this point, the following are options:

1. Install the weatherization plate, if the I-TEC unit is not ready to be installed.

**NOTE:** *The exhaust sleeve attaches to the I-TEC unit. Store it and any remaining mounting hardware in a safe location.*

2. Proceed to instructions on page 8 for attachment of the wall sleeve to the I-TEC unit.

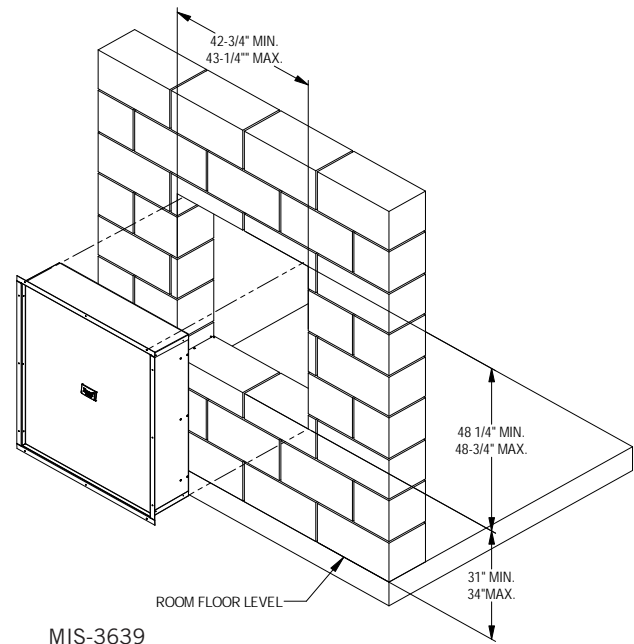
## Installation – Masonry Construction Walls

For masonry construction walls, the minimum dimensions for the opening will be 48-1/4" tall by 42-3/4" wide (see Figure 6). These dimensions are measured from the finished floor height. These will be the finish dimensions of the opening.

The intake sleeve should be test fit in the opening before final preparations are made. The sleeve will be installed into the opening from the outside of the building in. The sleeve must be centered in the opening from side to side. The mounting flanges of the sleeve must contact the outside wall all around the opening. The side and top mounting flanges must have the mounting holes drilled into the outside wall for the concrete anchors which will hold the sleeve in the wall.

The holes should be drilled through the holes in the sleeve with the sleeve level and square in the opening. A slope is built into the bottom of the sleeve from the inside to the outside. This will allow any water that gets into the sleeve to drain out. Once the test fitting has

**FIGURE 6**  
Masonry Construction Installation



been checked out, the sleeve should be removed from the wall.

With the sleeve removed, two 1/4" beads of sealant must be applied to the flanges that contact the outside wall (see Figure 5).

The sleeve must be installed back in the wall making sure that the predrilled holes in the wall line up with the holes in the mounting flanges of the sleeve. Check to make sure that there is enough sealant between the wall and the flanges to make the joint watertight. Additional sealant must be applied as required. The sleeve must be anchored to the wall. All four mounting flanges must be fastened to the outside wall using twelve (12) field-supplied masonry screws.

The inner portion of the intake sleeve must be inserted from the inside of the building. While holding the flanged side of the sleeve, slide it into the outer sleeve and insert far enough so it projects approximately 1/2" from either the smooth wall surface or from the sill. Final adjustment must be done from the outside.

On the inside of the building, the gaps between the sleeve and the rough wall opening must be filled with insulation.

**NOTE:** *If foamed insulation is used, the final location of the inner sleeve must be determined since the foam insulation could lock the inner sleeve into an incorrect location causing either an air leak between sleeve and back of unit or preventing the unit from going as tight to the wall or sill as desired. This must be done before the unit is placed and before the inner portion of the intake sleeve is secured with screws to the outer sleeve.*

Insulating this space will prevent infiltration of any unwanted outside air (see Figure 7).

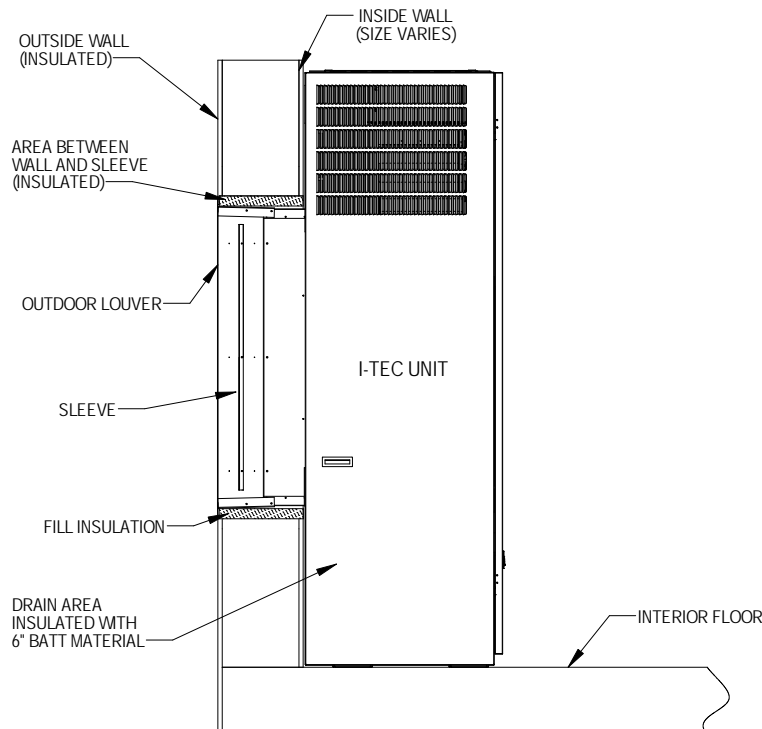
If the I-TEC unit will be drained through the wall, the drain line must be installed prior to setting the unit. Information for the drain installation is provided in the installation instructions supplied with the unit. At this point, the following are options:

1. Install the weatherization plate, if the I-TEC unit is not ready to be installed.

**NOTE:** The exhaust sleeve attaches to the I-TEC unit. Store it and any remaining mounting hardware in a safe location.

2. Proceed to instructions below for attachment of the wall sleeve to the I-TEC unit.

**FIGURE 7**  
**Typical Installation**



MIS-2928 C

### **Attachment of Wall Sleeve to I-TEC Unit (3-Piece Severe Duty Louver Shown)**

1. Prepare wall opening per wood framed or masonry construction instructions (see pages 6 and 7). Install sleeve in opening; be sure to apply a bead of silicone sealant behind mounting flange (see Figure 5).
2. Extend inner intake sleeve beyond inner wall surface by 1/2". Attach inner intake sleeve to outer intake sleeve using six (6) 5/16" x 3/4" self-tapping screws (supplied), three (3) along each side (see Figure 8). Use silicone sealant to caulk the seam between the inner intake sleeve and outer intake sleeve.
3. Install 3-piece louver (not supplied). Holes will need to be drilled where required to bolt louver to structure per specified building codes.
4. Remove center section of louver.
5. Move the I-TEC unit into place ensuring it is aligned side to side. Push unit back until the side panels are flush with the wall or until the sides contact the window sill (if applicable). Foam gasket on sleeve should be compressed between sleeve and unit. Attach inner intake sleeve to the rear of the unit with twelve (12) 5/16" x 3/4" self-tapping screws (supplied), using care to avoid damaging the gasketing material.
6. Install exhaust sleeve to unit fan shroud using six (6) 5/16" x 3/4" non-tapping screws (supplied) as shown in Figure 8. Pull inner exhaust sleeve frame out until flush with back of louver. Attach inner exhaust sleeve to outer exhaust sleeve using four (4) 5/16" x 1/2" non-tapping screws (supplied).
7. Make sure all rain exposed seams are sealed.
8. Replace center section of louver.



**FIGURE 8**  
**Attachment of Wall Sleeve**

Use (12) Field Supplied Concrete or Wood Screws to Secure Outer Sleeve to Structure.

**IMPORTANT!**

Apply Caulk bead to entire perimeter seam between inner and outer sleeve.

Use (12) 3/4" Long Self Tapping Screws to Attach Inner Sleeve to Unit Back

**IMPORTANT!**

Apply liberal amount of caulk to back of flange before installing.

REF. A

Use (6) 3/4" Long Self Tapping Screws to Attach Inner Sleeve to Outer Sleeve

REF. B

**IMPORTANT!**

Use care when inserting screws to not damage gasketing material. Doing so may compromise water seal between unit and sleeve.




Pull Inner Frame Out Until Flush With Louver back

Use (6) 3/4" Long Non-Tapping Screws to Attach Exhaust Sleeve to Unit Fan Shroud

REF. C

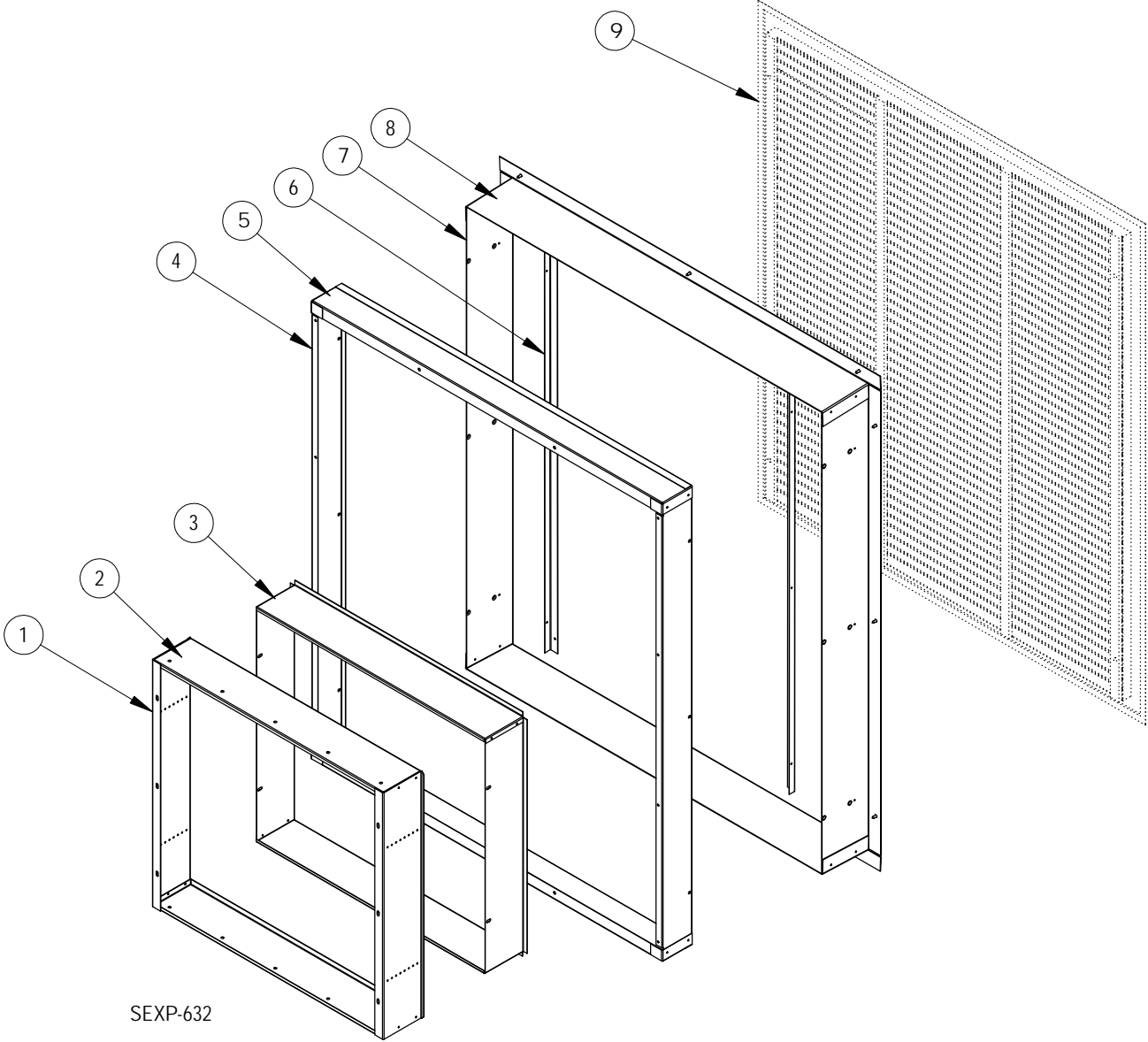
Use (4) 1/2" Long Screws to Attach Inner Exhaust Sleeve to Outer Exhaust Sleeve

REF. D

(18) 5/16" - 3/4" SELF TAPPING	REF. A AND B	
(6) 5/16" - 3/4" NON-TAPPING	REF. C	
(4) 5/16" - 1/2" NON-TAPPING	REF. D	

MIS-3640C

# REPLACEMENT PARTS



SEXP-632

Dwg No.	Part Number	Description	IWS-A8H	IWS-B8H	IWS-C8H
1	111-230-8BX	Outer Fan Sleeve Side	2		
	111-237-8BX	Outer Fan Sleeve Side		2	
	111-195-8BX	Outer Fan Sleeve Side			2
2	111-229-8BX	Outer Fan Sleeve End	2		
	111-237-8BX	Outer Fan Sleeve End		2	
	111-194-8BX	Outer Fan Sleeve End			2
3	111-231-8BX	Inner Fan Sleeve Side	2		
	111-238-8BX	Inner Fan Sleeve Side		2	
	111-196-8BX	Inner Fan Sleeve Side			2
4	111-228-8BX	Inner Sleeve Side	2		
	111-235-8BX	Inner Sleeve Side		2	
	111-339-8BX	Inner Sleeve Side			2
5	111-227-8BX	Inner Sleeve End	2		
	111-234-8BX	Inner Sleeve End		2	
	111-338-8BX	Inner Sleeve End			2
6	105-1395-8BX	Grille Support Angle	2	2	2
7	111-226-8BX	Outer Sleeve Side	2		
	111-233-8BX	Outer Sleeve Side		2	
	111-337-8BX	Outer Sleeve Side			2
8	111-225-8BX	Outer Sleeve End	2		
	111-232-8BX	Outer Sleeve End		2	
	111-336-8BX	Outer Sleeve End			2
9	107-358BX	Wall Sleeve Cover Plate	X	X	X
	Reference Spec. Sheet	Outdoor Louver Grille			