

---

# INSTALLATION AND SERVICE INSTRUCTIONS

---

## DUAL-TEC™ WALL-MOUNT PACKAGE AIR CONDITIONER

Models:

|         |         |         |         |         |         |
|---------|---------|---------|---------|---------|---------|
| D25A2PA | D35A2PA | D42A2PA | D25L2PA | D35L2PA | D42L2PA |
|         | D35A2PB | D42A2PB | D25L2PB | D35L2PB | D42L2PB |
| D28A2PA | D36A2PA | D48A2PA | D28L2PA | D36L2PA | D48L2PA |
| D28A2PB | D36A2PB | D48A2PB | D28L2PB | D36L2PB | D48L2PB |
|         |         | D60A2PA |         |         | D60L2PA |
|         |         | D60A2PB |         |         | D60L2PB |

**Part of the Bard DC Free Cooling Unit System**

***NOTE: LC Series Controllers must be used with  
D-Series Wall-Mount Units***



Climate Control Solutions

Bard Manufacturing Company, Inc.  
Bryan, Ohio 43506  
[www.bardhvac.com](http://www.bardhvac.com)

Manual: 2100-643C  
Supersedes: 2100-643B  
Date: 7-28-16

# CONTENTS

---

|   |           |
|---|-----------|
| <b>SECTION 1: Installation Instructions .....</b> | <b>5</b>  |
| List of Necessary Materials/Tools .....           | 6         |
| Site Preparation .....                            | 7         |
| Wall-Mount Unit Installation .....                | 9         |
| Wall-Mount Unit Supply Wiring.....                | 15        |
| Preliminary Start-Up.....                         | 19        |
| <b>SECTION 2: Service Instructions .....</b>      | <b>21</b> |
| General Refrigerant Information.....              | 22        |
| Sequence of Operation .....                       | 24        |
| Using the TEC-EYE™ .....                          | 27        |
| Componentry Specifications .....                  | 30        |
| Maintenance and Troubleshooting.....              | 38        |
| <b>SECTION 3: Appendix .....</b>                  | <b>45</b> |
| Wall-Mount Unit Architecture .....                | 46        |

## FIGURES AND TABLES

|             |  |    |
|-------------|--|----|
| Figure 1.1  | Wall-Mount Unit Model Nomenclature .....                           | 6  |
| Figure 1.2  | Dimensions.....  | 8  |
| Figure 1.3A | D25A, D25L, D35A, D35L<br>Mounting Instructions.....               | 10 |
| Figure 1.3B | D28A, D28L, D36A, D36L, D42A, D42L,<br>Mounting Instructions.....  | 11 |
| Figure 1.3C | D48A, D48L, D60A, D60L<br>Mounting Instructions.....               | 12 |
| Figure 1.4  | Electric Heat Clearance.....                                       | 13 |
| Figure 1.5  | Wall Mounting Instructions.....                                    | 13 |
| Figure 1.6  | Wall Mounting Instructions.....                                    | 14 |
| Figure 1.7  | Common Wall Mounting Installations.....                            | 14 |
| Figure 1.8  | Circuit Routing Label.....   | 15 |
| Figure 1.9  | <b>WIRING:</b> VAC and VDC Supply Wiring<br>Landing Points.....    | 17 |
| Figure 1.10 | Adjusting the 230/208VAC Transformer..                             | 17 |
| Figure 1.11 | Bard Polarity-Voltage Monitor.....                                 | 18 |
| Figure 2.1  | Refrigerant Sight Glass .....                                      | 23 |
| Figure 2.2  | Wall-Mount Unit Control Board .....                                | 25 |
| Figure 2.3  | TEC-EYE™ Display.....  | 27 |
| Figure 2.4  | TEC-EYE™ Connection to Unit Control....                            | 27 |
| Figure 2.5  | TEC-EYE™ Status Display.....                                       | 28 |
| Figure 2.6  | Fan Blade Setting.....   | 32 |
| Figure 2.7  | Dirty Filter Switch.....   | 32 |
| Figure 2.8  | Power Loss Relay Circuit .....                                     | 33 |
| Figure 2.9  | High Pressure Relay Circuit .....                                  | 33 |
| Figure 2.10 | Blower Motor Start Relay Circuit .....                             | 33 |
| Figure 2.11 | D25A/L, D35A/L Unit Control Panel .....                            | 34 |
| Figure 2.12 | D28A/L, D36A/L, D42A/L, D48A/L,<br>D60A/L Unit Control Panel ..... | 35 |
| Figure 2.13 | <b>WIRING:</b> D25A/L, D35A/L<br>Unit Wiring Diagram .....         | 36 |
| Figure 2.14 | <b>WIRING:</b> D28A/L, D36A/L, D42A/L, .....                       | 37 |
| Figure 2.15 | D48A/L, D60A/L Unit Wiring Diagram ....                            | 37 |
| Figure 2.15 | Troubleshooting Motor Power Supply .....                           | 39 |
| Figure 2.16 | Troubleshooting Motor Start Command ...                            | 40 |
| Figure 2.17 | Troubleshooting Speed Voltage.....                                 | 40 |
| Figure 2.18 | VDC Polarity Check.....  | 41 |
| Figure 2.19 | Verifying Incoming Voltage: VDC.....                               | 42 |
| Table 1.1   | Electrical Specifications .....                                    | 16 |
| Table 2.1   | Nominal Pressures .....  | 23 |
| Table 2.2   | Blower Speed Voltage Chart .....                                   | 24 |
| Table 2.3   | Temp vs. Resistance of Temp Sensor. ....                           | 31 |
| Table 2.4   | Indoor Blower Performance .....                                    | 32 |
| Table 2.5   | Troubleshooting 48VDC Blower Motor.....                            | 39 |
| Table 2.6   | Blower Speed Voltage Chart .....                                   | 40 |

# GENERAL INFORMATION

## DC FREE COOLING UNIT SYSTEM

The Bard DC Free Cooling Unit system is composed of two (2) D-Series DUAL-TEC™ wall-mount air conditioners matched with one (1) LC Series lead/lag controller. The D-Series, specifically engineered for the telecom market, can provide outdoor air cooling during power loss situations through the use of onsite -48VDC positive ground battery banks.

**NOTE:** *The LC Series lead/lag controller and the D-Series wall-mount units are designed specifically to work together. The controller cannot run other Bard models or other brands of systems, nor can other controllers or thermostats run the D-Series wall-mount units. They are a complete system, and must be used together.*

## WALL-MOUNT AIR CONDITIONER UNITS

The D-Series units operate on both VAC and VDC power under normal power supply conditions. If there is loss of VAC power supply (shore and/or back-up generator) the unit will continue to operate as free cooling or ventilation system using the shelter's VDC power. The indoor blower and free cooling unit operate from -48VDC and no inverter is required.

The units will supply 100% of rated cooling airflow in free cooling mode with ability to exhaust the same amount through the unit itself without any additional relief openings in the shelter.

Each of these units are fully charged with refrigerant and have auxiliary heat installed.

## GENERAL

The equipment covered in this manual is to be installed by trained, experienced service and installation technicians.

The refrigerant system is completely assembled and charged. All internal wiring is complete.

The unit is designed for use with or without duct work. Flanges are provided for attaching the supply and return ducts.

These instructions explain the recommended method to install the air cooled self-contained unit and the electrical wiring connections to the unit.

These instructions and any instructions packaged with any separate equipment required to make up the entire air conditioning system should be carefully read before beginning the installation. Note particularly any tags and/or labels attached to the equipment.

While these instructions are intended as a general recommended guide, they do not supersede any national and/or local codes in any way. Authorities having jurisdiction should be consulted before the installation is made. See **ADDITIONAL PUBLICATIONS** for information on codes and standards.

Sizing of systems for proposed installation should be based on heat loss calculation made according to methods of Air Conditioning Contractors of America (ACCA). The air duct should be installed in accordance with the *Standards of the National Fire Protection Association for the Installation of Air Conditioning and Ventilating Systems of Other Than Residence Type, NFPA No. 90A, and Residence Type Warm Air Heating and Air Conditioning Systems, NFPA No. 90B*. Where local regulations are at a variance with instructions, installer should adhere to local codes.

## SHIPPING DAMAGE

Upon receipt of equipment, the cartons should be checked for external signs of shipping damage. If damage is found, the receiving party must contact the last carrier immediately, preferably in writing, requesting inspection by the carrier's agent.

These units must remain in upright position at all times.

## ADDITIONAL PUBLICATIONS

These publications can help when installing the air conditioning system. They can usually be found at the local library or purchased directly from the publisher. Be sure to consult the current edition of each standard.

National Electrical Code .....ANSI/NFPA 70  
Standard for the Installation of Air Conditioning and Ventilating Systems .....ANSI/NFPA 90A  
Standard for Warm Air Heating and Air Conditioning Systems .....ANSI/NFPA 90B  
Load Calculation for Residential Winter and Summer Air Conditioning ..... ACCA Manual J  
Duct Design for Residential Winter and Summer Air Conditioning and Equipment Selection ..... ACCA Manual D

For more information, contact these publishers:

### **Air Conditioning Contractors of America (ACCA)**

1712 New Hampshire Ave. N.W.

Washington, DC 20009

Telephone: (202) 483-9370 Fax: (202) 234-4721

### **American National Standards Institute (ANSI)**

11 West Street, 13th Floor

New York, NY 10036

Telephone: (212) 642-4900 Fax: (212) 302-1286

**American Society of Heating, Refrigeration and Air Conditioning Engineers, Inc. (ASHRAE)**

1791 Tullie Circle, N.E.  
Atlanta, GA 30329-2305  
Telephone: (404) 636-8400 Fax: (404) 321-5478

**National Fire Protection Association (NFPA)**

Batterymarch Park  
P. O. Box 9101  
Quincy, MA 02269-9901  
Telephone: (800) 344-3555 Fax: (617) 984-7057

**ANSI Z535.5 Definitions:**

**Danger:** Indicate[s] a hazardous situation which, if not avoided, will result in death or serious injury. The signal word “DANGER” is to be limited to the most extreme situations. DANGER [signs] should not be used for property damage hazards unless personal injury risk appropriate to these levels is also involved.

**Warning:** Indicate[s] a hazardous situation which, if not avoided, could result in death or serious injury. WARNING [signs] should not be used for property damage hazards unless personal injury risk appropriate to this level is also involved.

**Caution:** Indicate[s] a hazardous situation which, if not avoided, could result in minor or moderate injury. CAUTION [signs] without a safety alert symbol may be used to alert against unsafe practices that can result in property damage only.

**Notice:** [this header is] preferred to address practices not related to personal injury. The safety alert symbol shall not be used with this signal word. As an alternative to “NOTICE” the word “CAUTION” without the safety alert symbol may be used to indicate a message not related to personal injury.



 **WARNING**

*Electrical shock hazard.*

*Have a properly trained individual perform these tasks.*

*Failure to do so could result in electric shock or death.*

 **WARNING**

*Fire hazard.*

*Maintain minimum 1/4” clearance between the supply air duct and combustible materials in the first 3’ feet of ducting.*

*Failure to do so could result in fire causing damage, injury or death.*

 **WARNING**

*Heavy item hazard.*

*Use more than one person to handle unit.*

*Failure to do so could result in unit damage or serious injury.*

 **CAUTION**

*Cut hazard.*

*Wear gloves to avoid contact with sharp edges.*

*Failure to do so could result in personal injury.*

# **SECTION 1:**

# **INSTALLATION**

# **INSTRUCTIONS**

# LIST OF NECESSARY MATERIALS/TOOLS

Additional hardware and miscellaneous supplies are needed for installation. These items are field supplied and must be sourced before installation. This list also includes tools needed for installation.

## LIST OF MATERIALS/TOOLS

- Personal protective equipment/safety devices
- Supply/return grilles
- Field-fabricated sleeves (if necessary)
- Fasteners sufficient for mounting the units such as 5/16" diameter anchor/carriage/lag bolts
- 7/8" diameter washers
- Caulking materials
- Miscellaneous hand and power tools and jobsite or shop materials
- Lifting equipment with the necessary capacity and rigging to safely move/install the systems
- Electrical supplies:
  - Two (2) 20A circuit breakers for the shelter DC power plant (one per wall-mount unit)
  - Two (2) various size circuit breakers for the shelter AC breaker box (see Table 1.1: Electrical Specifications on page 16)
  - High-voltage wire of various gauges (see Table 1.1)
  - Communication wire: 2-wire, 18 gauge, shielded with drain
  - Miscellaneous electrical supplies including rigid/flexible conduit and fittings, junction boxes, wire connectors and supports

## NOTICE

The following are required and must be sourced prior to installation of these units.

- Two (2) 20A circuit breakers for the shelter DC power plant (one per wall-mount unit)

Circuit breakers for Emerson Network Power (ENP) power plants (used in most telecomm shelters built today) are available directly through the following distributors:

- Emerson Network Power: 440.288.1122
- Master Electronics: 888.473.5297 or [www.onlinecomponents.com](http://www.onlinecomponents.com)

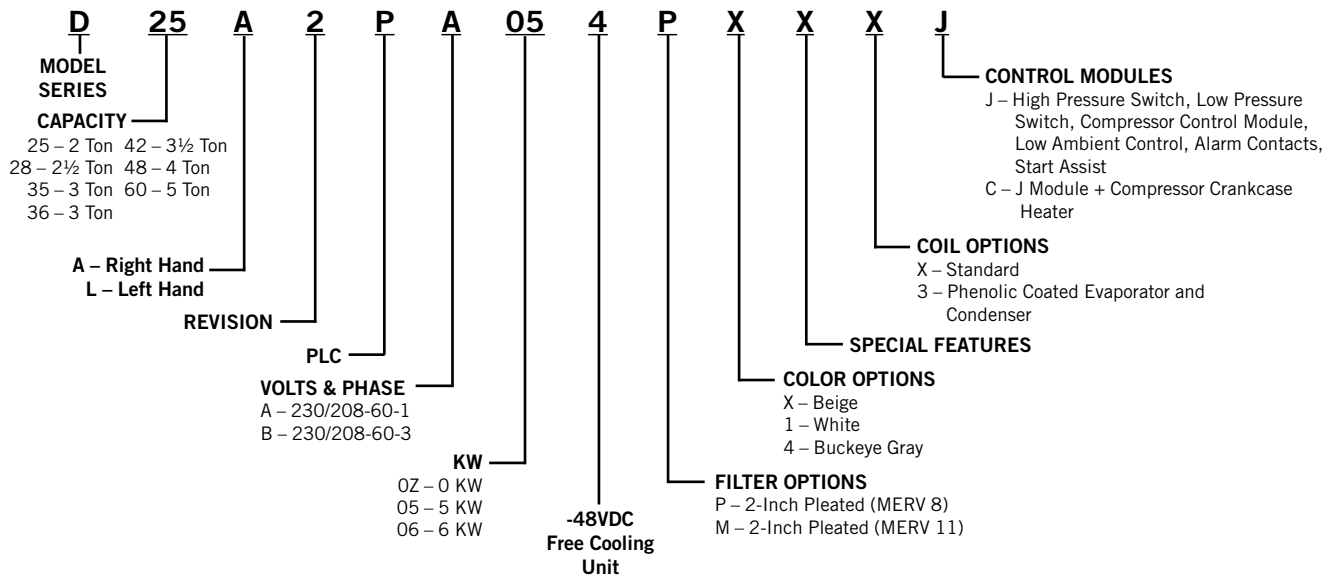
Emerson Network Power (ENP) Part Number

- 20A circuit breaker: P/N 101601

Always confirm the application before ordering.

FIGURE 1.1

### D-Series DUAL-TEC™ Wall-Mount Unit Model Nomenclature



## NEW SHELTER INSTALLATION VS. RETROFIT INSTALLATION

These installation instructions cover both new shelter installations and retrofit installations. Each installation is unique and may require special accommodations and modifications. Although Bard Manufacturing follows a long-established tradition of manufacturing equipment using industry standard dimensions for building penetration, it is occasionally necessary to move or enlarge supply and return openings when replacing non-standardized equipment in a retrofit application.

### MINIMUM CLEARANCE

D-Series wall-mount air conditioners are available in both right-hand access models and left-hand access models. Right-hand access models have the heat strip access panel, external circuit breakers access panel and internal controls access panel on the right side of the unit. Left-hand access models are a mirror image of the right-hand access models, and allow two wall-mount units to be placed in relatively close proximity and yet still allow complete access for maintenance and repair.

On side-by-side installations, maintain a minimum of 26" clearance on control side to allow access to control panel and heat strips, and to allow proper airflow to the outdoor coil. For installations where units are installed with both control panels facing each other (inward), maintain a minimum of 36" clearance to allow access. Additional clearance may be required to meet local or national codes.

Care should be taken to ensure that the recirculation and obstruction of condenser discharge air does not occur. Recirculation of condenser discharge air can be from either a single unit or multiple units. Any object such as shrubbery, a building or a large object can cause obstructions to the condenser discharge air. Recirculation or reduced airflow caused by obstructions will result in reduced capacity, possible unit pressure safety lockouts and reduced unit service life.

For units with blow through condensers, such as the D-Series units, it is recommended there be a minimum distance of 10' between the front of the unit and any barrier or 20' between the fronts of two opposing (facing) units.

### ***Clearances Required for Service Access and Adequate Condenser Airflow***

| MODELS   | LEFT SIDE         | RIGHT SIDE |
|--|-------------------|------------|
| All covered by this manual                           | 26"               | 26"        |
| Units with control panels facing each other (inward) | 36" between units |            |

## CLEARANCE TO COMBUSTIBLES

### **WARNING**

***Fire hazard.***

***Maintain minimum 1/4" clearance between the supply air duct and combustible materials in the first 3' of ducting.***

***Failure to do so could result in fire causing damage, injury or death.***

The unit itself is suitable for 0" clearance, but the supply air duct flange and the first 3' of supply air duct require a minimum of 1/4" clearance to combustible material. However, it is generally recommended that a 1" clearance is used for ease of installation and maintaining the required clearance to combustible material. See Figures 1.3A-C on pages 10-12 for details on opening sizes.

### ***Minimum Clearances Required to Combustible Materials***

| MODELS                     | SUPPLY AIR DUCT FIRST 3' | CABINET |
|----------------------------|--------------------------|---------|
| All covered by this manual | 1/4"                     | 0"      |

### MODEL IDENTIFICATION

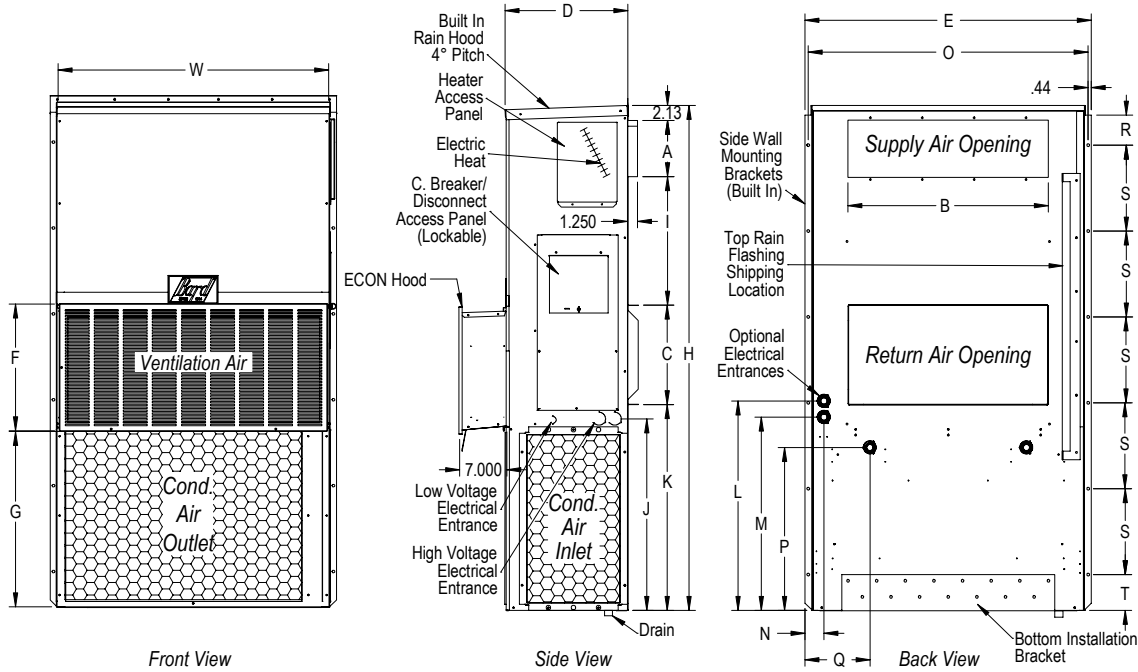
Identify the specific model using the model nomenclature information found in Figure 1.1 and/or model/serial tag found on the unit on the opposite side of the control and access panels. See Figure 1.2 on page 8 for dimensions and critical installation requirements.

**FIGURE 1.2**  
**Dimensions of Basic Unit for Architectural and Installation Requirements (Nominal)**

| Model                      | Width (W) | Depth (D) | Height (H) | Supply |       | Return |       |       |       |       |       |       |       |       |       |      |       |       |       |      |       |       |
|----------------------------|-----------|-----------|------------|--------|-------|--------|-------|-------|-------|-------|-------|-------|-------|-------|-------|------|-------|-------|-------|------|-------|-------|
|                            |           |           |            | A      | B     | C      | B     | E     | F     | G     | I     | J     | K     | L     | M     | N    | O     | P     | Q     | R    | S     | T     |
| D25A/L<br>D35A/L           | 38.200    | 17.125    | 74.563     | 7.88   | 27.88 | 13.88  | 27.88 | 40.00 | 10.88 | 29.75 | 17.93 | 30.75 | 32.75 | 33.25 | 31.00 | 2.75 | 39.13 | 26.75 | 9.14  | 4.19 | 12.00 | 9.00  |
| D28A/L<br>D36A/L<br>D42A/L | 42.075    | 22.432    | 84.875     | 9.88   | 29.88 | 15.88  | 29.88 | 43.88 | 13.56 | 31.66 | 30.00 | 32.68 | 26.94 | 34.69 | 32.43 | 3.37 | 43.00 | 23.88 | 10.00 | 1.44 | 16.00 | 1.88  |
| D48A/L<br>D60A/L           | 42.075    | 22.432    | 93.000     | 9.88   | 29.88 | 15.88  | 29.88 | 43.88 | 13.56 | 37.00 | 30.00 | 40.81 | 35.06 | 42.81 | 40.56 | 3.37 | 43.00 | 31.00 | 10.00 | 1.44 | 16.00 | 10.00 |

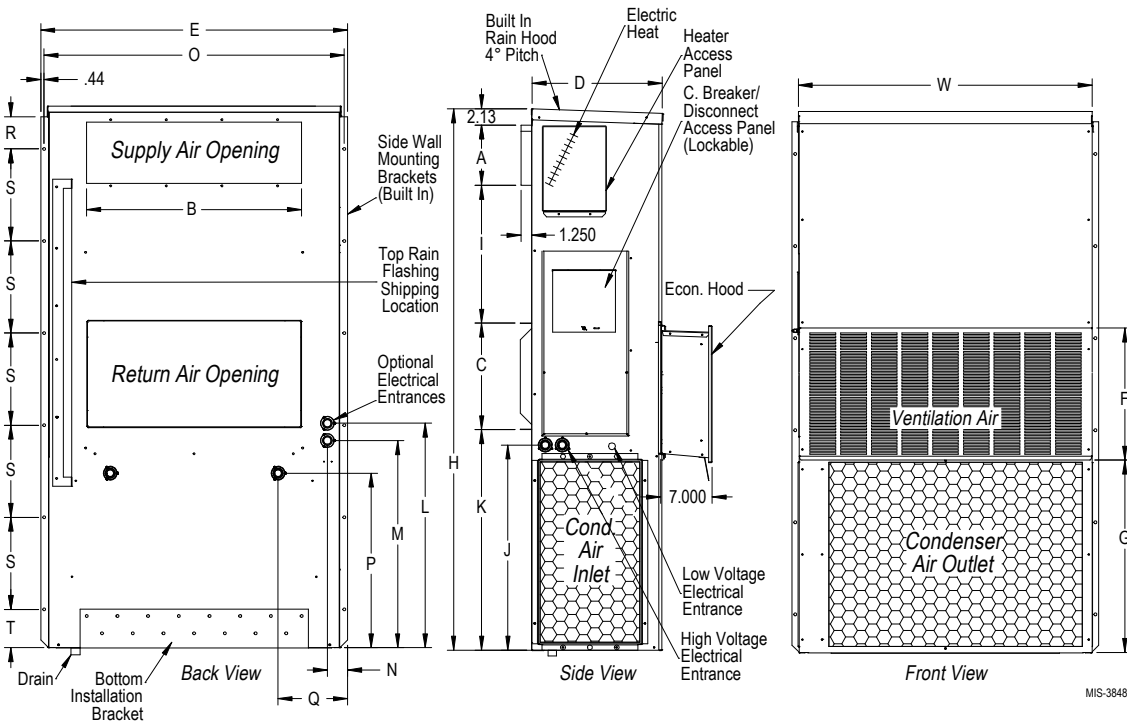
All dimensions are in inches. Dimensional drawings are not to scale.

**D\*\*A  
RIGHT  
HAND  
UNIT**



MIS-3849

**D\*\*L  
LEFT  
HAND  
UNIT**



MIS-3848



# WALL-MOUNT UNIT INSTALLATION

## MOUNTING THE UNITS

### **WARNING**

**Heavy item hazard.**

**Use more than one person to handle unit.**

**Failure to do so could result in unit damage or serious injury.**

**NOTE:** It may be best to spot some electrical knockouts (such as those located on the back of the wall-mount unit) before units are mounted and access is unavailable or limited (see Figure 1.2 to locate pre-punched knockouts).

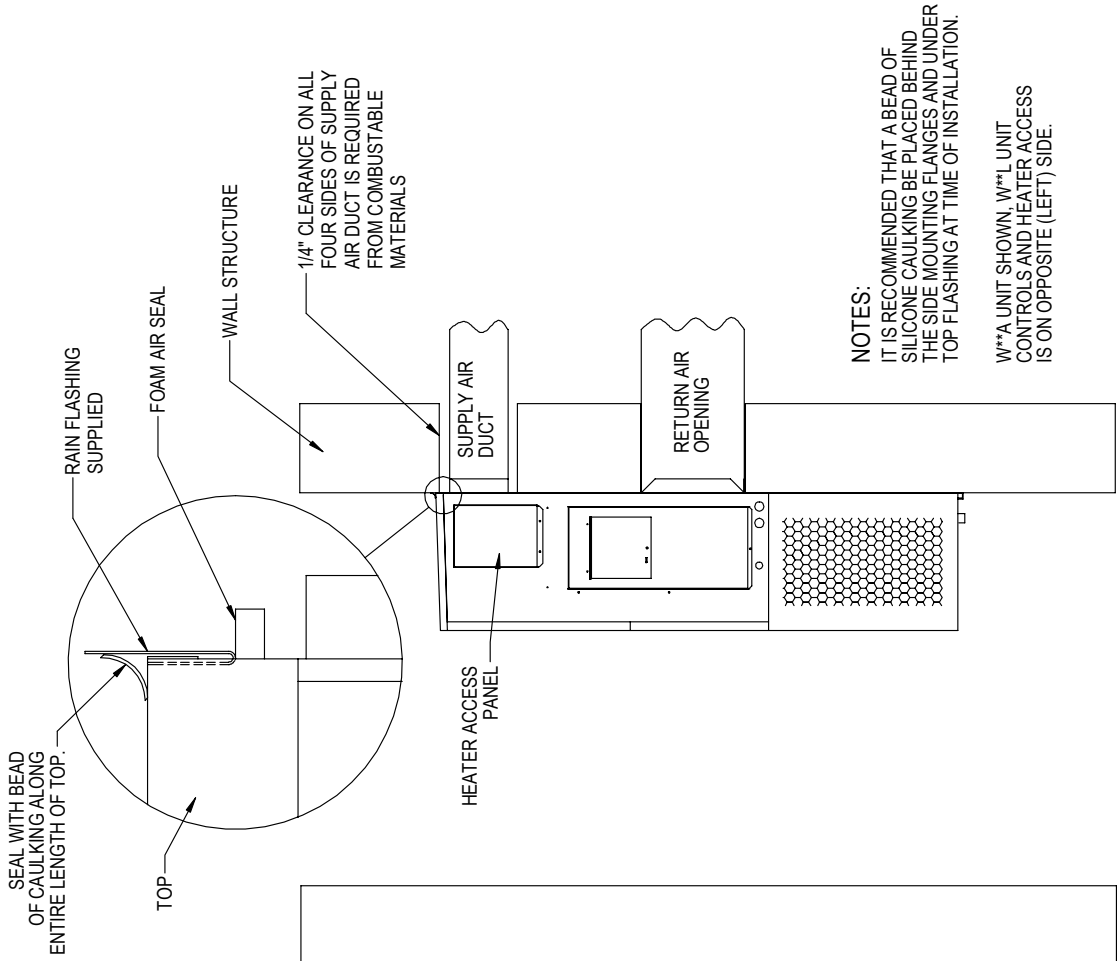
Two holes for the supply and return air openings must be cut through the wall as shown in Figures 1.3A-C on pages 10-12. On wood frame walls, the wall construction must be strong and rigid enough to carry the weight of the unit without transmitting any unit vibration. Concrete block walls must be thoroughly inspected to insure that they are capable of carrying the weight of the installed unit.

In retrofit (unit replacement) installations, the openings cut for the original equipment may not line up exactly with needs of this installation. Modifications may need to be made, such as increasing or decreasing the size of the wall cutouts. The existing bolt placement may not line up in which case the original bolts would need to be removed or cut away.

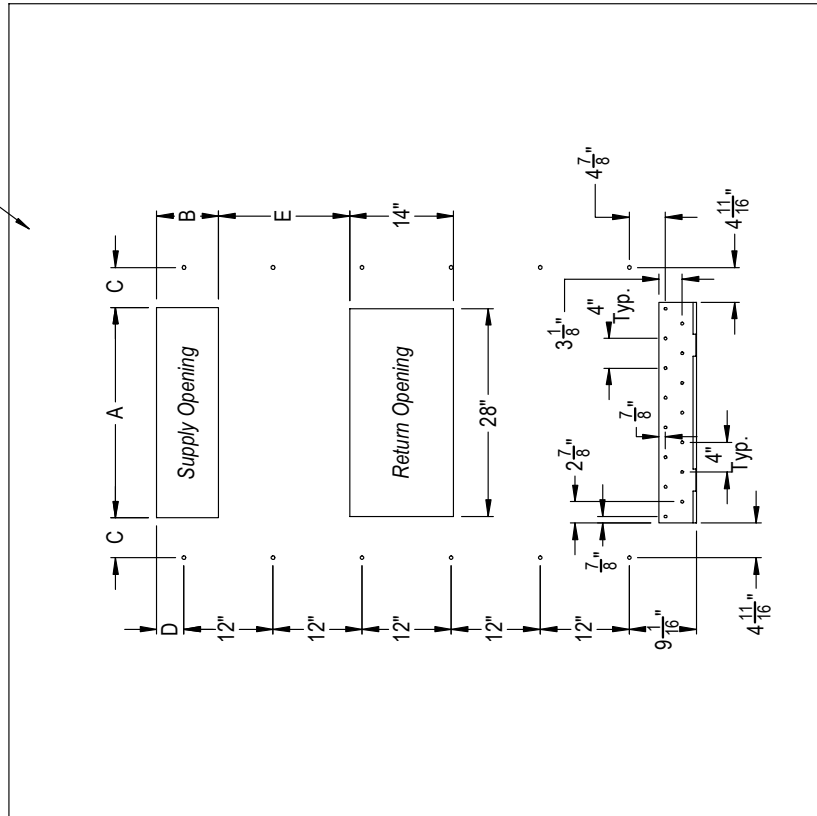
1. These units are secured by wall mounting flanges which secure the unit to the outside wall surface at both sides. A bottom mounting bracket, attached to skid for shipping, is provided for ease of installation, but is not required.
2. The unit itself is suitable for 0" clearance, but the supply air duct flange and the first 3' of supply air duct require a minimum of 1/4" clearance to combustible material. However, it is generally recommended that a 1" clearance is used for ease of installation and maintaining the required clearance to combustible material. See Figures 1.3A-C for details on opening sizes.
3. Locate and mark lag bolt locations and location for optional bottom mounting bracket, if desired (see Figures 1.3A-C).
4. Mount bottom mounting bracket (if used).
5. If desired, hook top rain flashing (attached to front-right of supply flange for shipping) under back bend of top.
6. Position unit in opening and secure with fasteners sufficient for the application such as 5/16" lag/anchor/carriage bolts; use 7/8" diameter flat washers on the bolts. It is recommended that a bead of silicone caulking be placed behind the side mounting flanges.
7. Secure optional rain flashing to wall and caulk across entire length of top (see Figures 1.3A-C).
8. For additional mounting rigidity, the return air and supply air frames or collars can be drilled and screwed or welded to the structural wall itself (depending upon wall construction). Be sure to observe required clearance if combustible wall.
9. A plastic drain hose extends from the drain pan at the top of the unit down to the unit base. There are openings in the unit base for the drain hose to pass through. In the event the drain hose is connected to a drain system of some type, it must be an open or vented type system to assure proper drainage.

**FIGURE 1.3A**  
**D25A, D25L, D35A, D35L**  
**Mounting Instructions**

|   | A      | B     | C     | D       | E      |
|---|--------|-------|-------|---------|--------|
| REQUIRED DIMENSIONS TO MAINTAIN 1/4" MIN. CLEARANCE FROM COMBUSTIBLE MATERIALS      | 28 3/8 | 8 3/8 | 5 3/8 | 3 11/16 | 17 5/8 |
| REQUIRED DIMENSIONS TO MAINTAIN RECOMMENDED 1" CLEARANCE FROM COMBUSTIBLE MATERIALS | 29 7/8 | 9 7/8 | 4 5/8 | 4 7/16  | 16 7/8 |

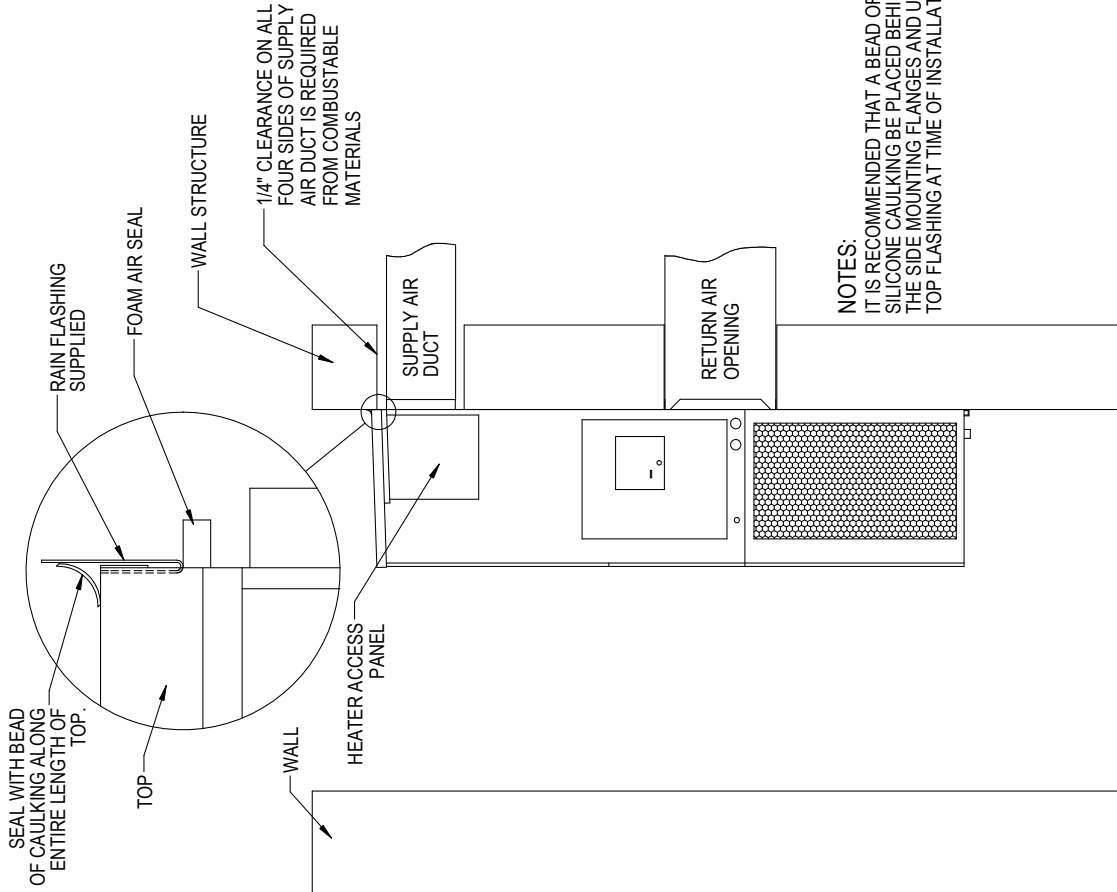


Right Side View



Wall Opening and Hole Location View

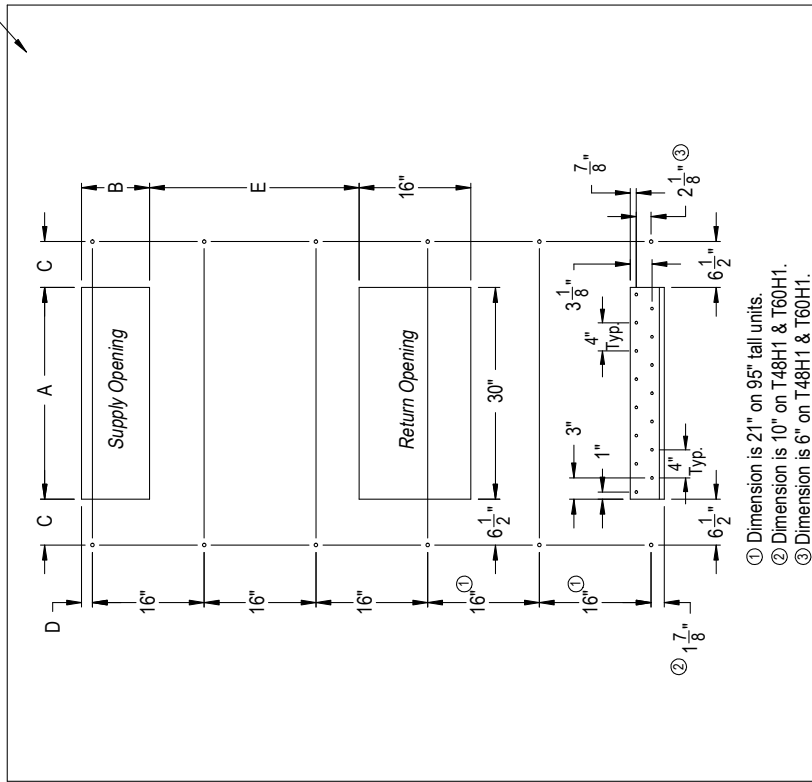
**FIGURE 1.3B**  
**D28A, D28L, D36A, D36L, D42A, D42L**  
**Mounting Instructions**



**NOTES:**  
 IT IS RECOMMENDED THAT A BEAD OF SILICONE CAULKING BE PLACED BEHIND THE SIDE MOUNTING FLANGES AND UNDER TOP FLASHING AT TIME OF INSTALLATION.

Right Side View

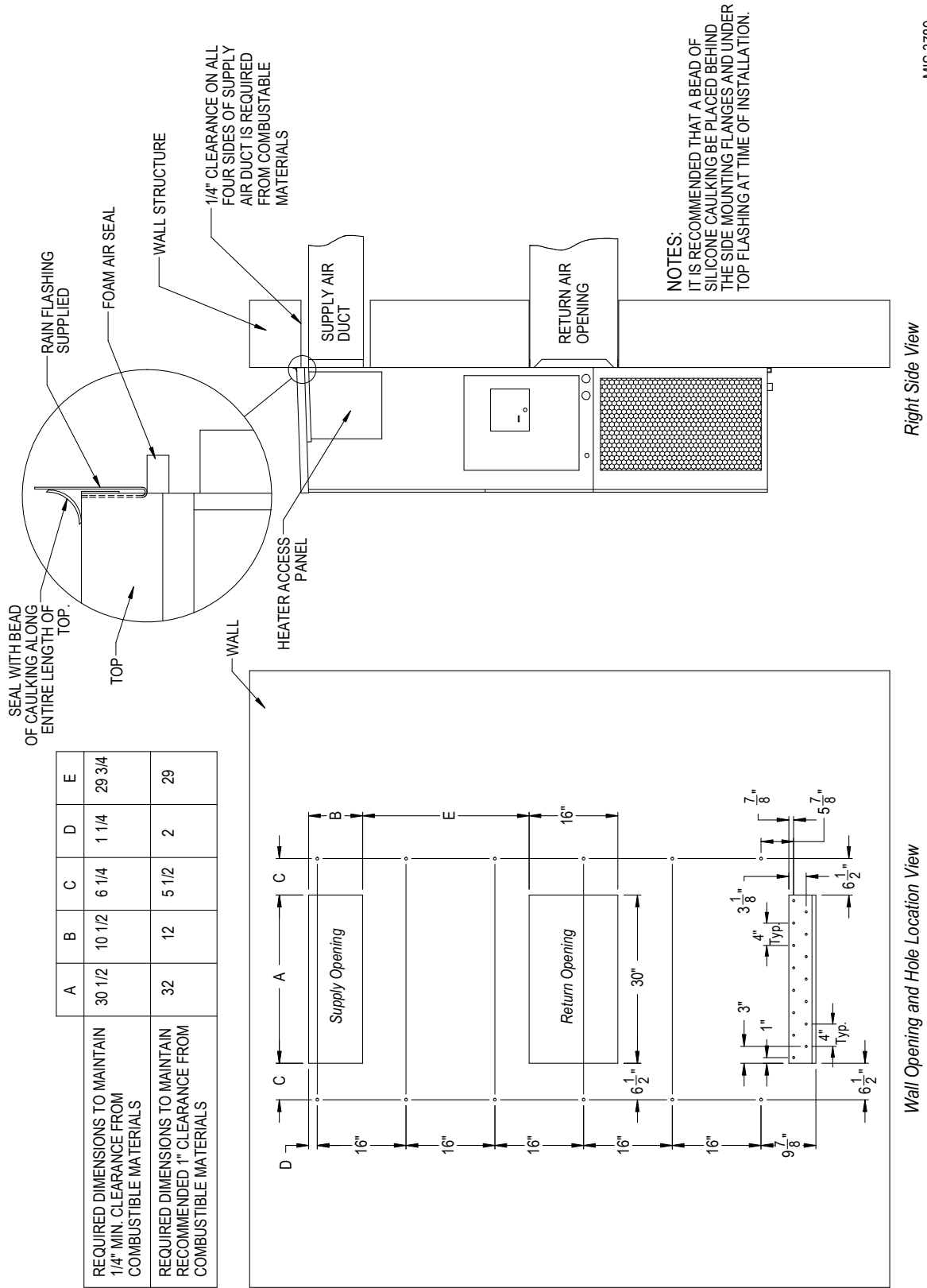
|   | A      | B      | C     | D     | E      |
|---|--------|--------|-------|-------|--------|
| REQUIRED DIMENSIONS TO MAINTAIN 1/4" MIN. CLEARANCE FROM COMBUSTIBLE MATERIALS      | 30 1/2 | 10 1/2 | 6 1/4 | 1 1/4 | 29 3/4 |
| REQUIRED DIMENSIONS TO MAINTAIN RECOMMENDED 1" CLEARANCE FROM COMBUSTIBLE MATERIALS | 32     | 12     | 5 1/2 | 2     | 29     |



- ① Dimension is 21" on 95" tall units.
- ② Dimension is 10" on T48H1 & T60H1.
- ③ Dimension is 6" on T48H1 & T60H1.

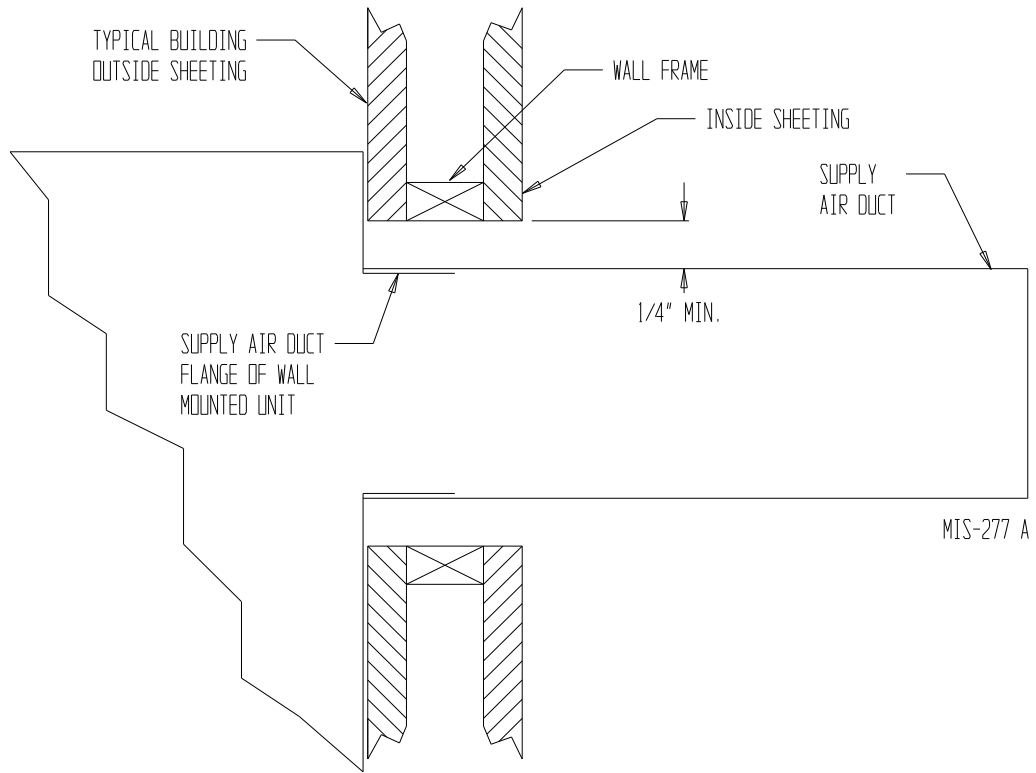
Wall Opening and Hole Location View

**FIGURE 1.3C**  
**D48A, D48L, D60A, D60L**  
**Mounting Instructions**

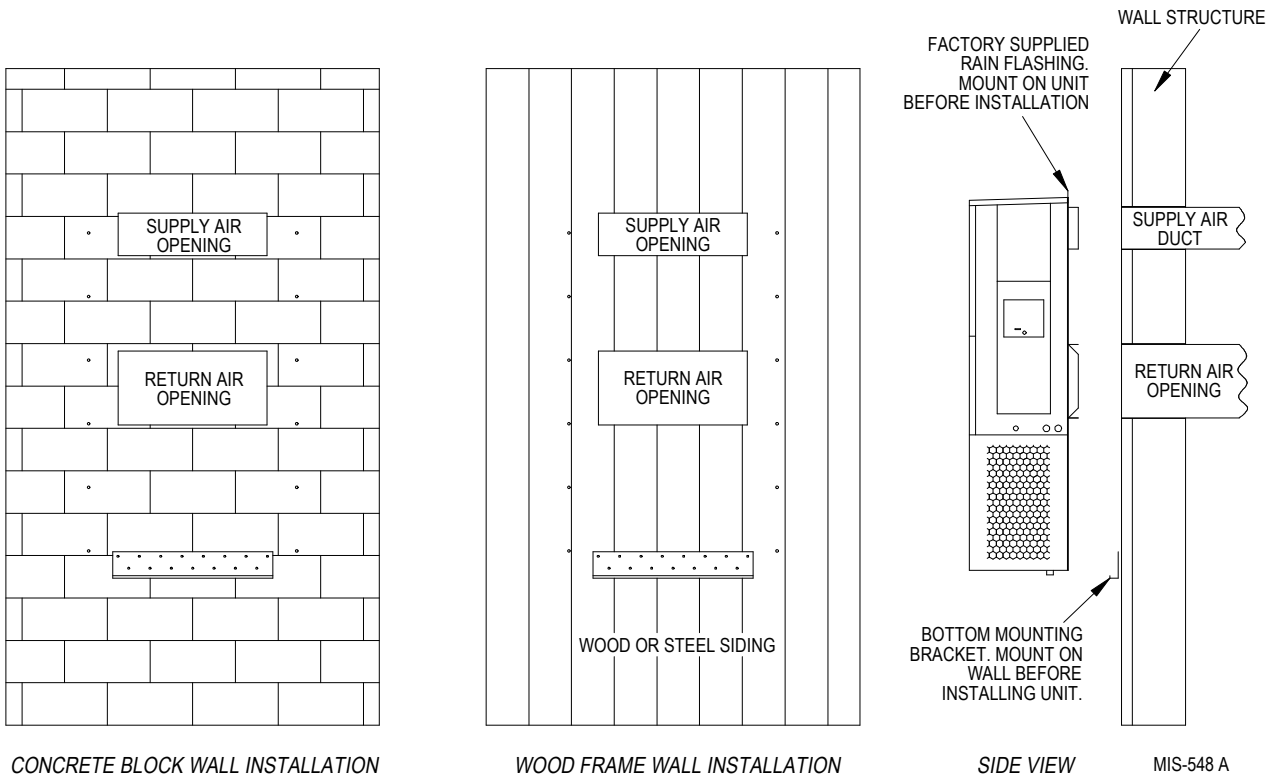


MIS-3789

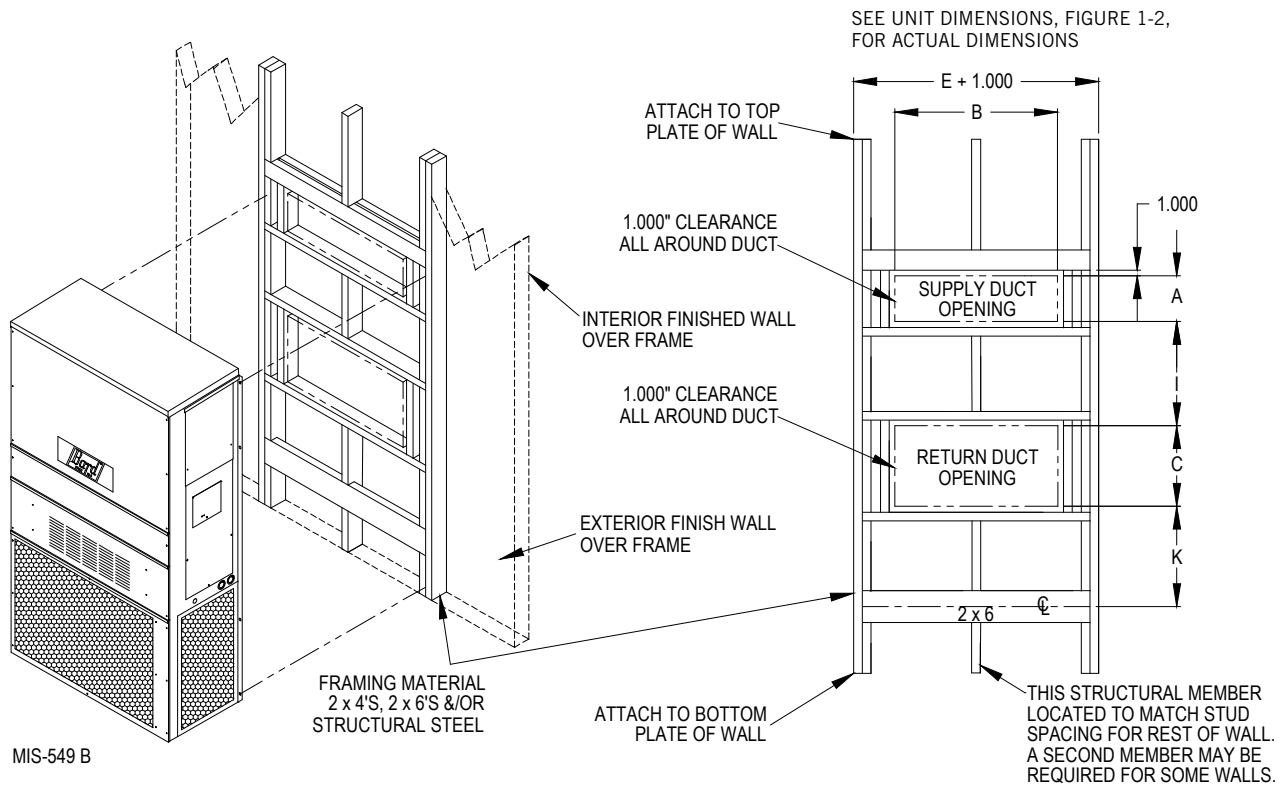
**FIGURE 1.4**  
**Electric Heat Clearance**



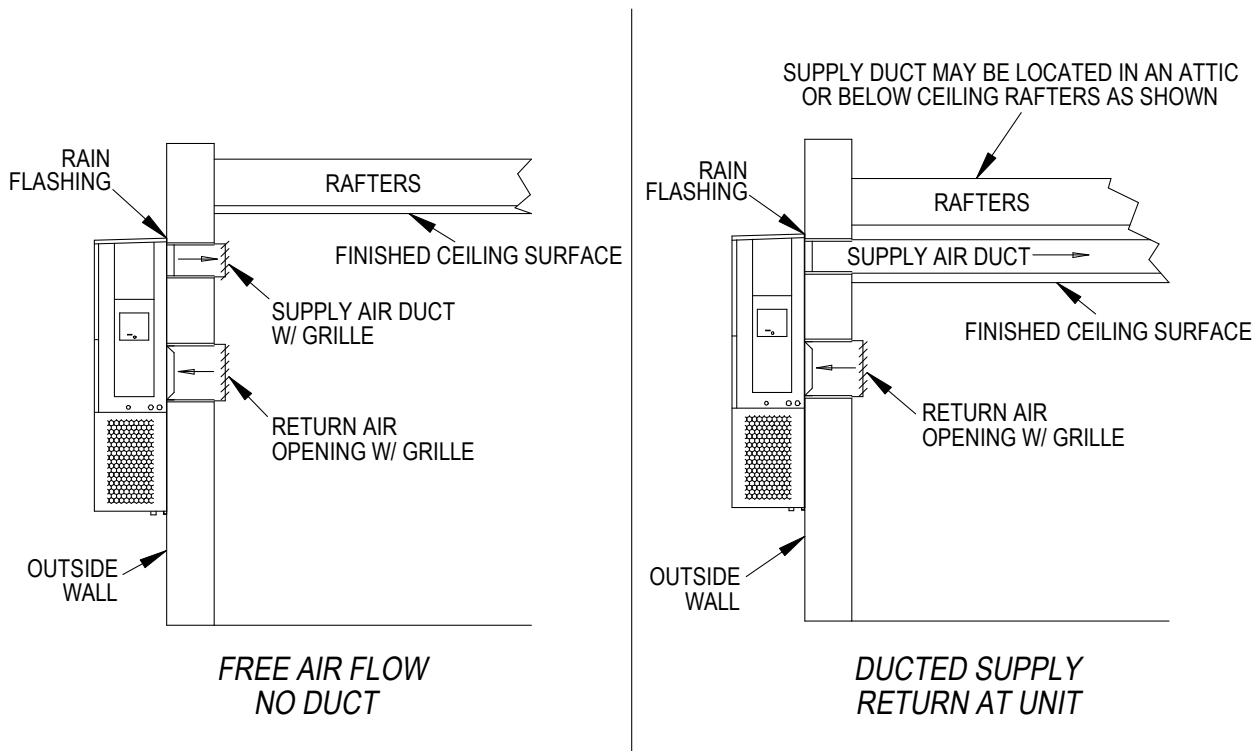
**FIGURE 1.5**  
**Wall Mounting Instructions**



**FIGURE 1.6**  
**Wall Mounting Instructions**



**FIGURE 1.7**  
**Common Wall Mounting Installations**



# WALL-MOUNT UNIT SUPPLY WIRING

## NOTICE

All models covered by this installation instruction require dual power sources: **VAC utility power** to run the compressor, heat and outdoor fan motor and **-48 VDC power** to operate the indoor blower and DC free cooling damper.

**These units require a positive ground -48 VDC copper conductor field wire connection.** Refer to the unit wiring diagram for more information.

## WARNING

**Electrical shock hazard.**

**Have a properly trained individual perform these tasks.**

**Failure to do so could result in electric shock or death.**

Refer to the unit rating plate or Table 1.1 on page 16 for wire sizing information and maximum fuse or circuit breaker size. Each outdoor unit is marked with a “Minimum Circuit Ampacity”. The field wiring used must be sized to carry that amount of current. All models are suitable only for connection with copper wire. Each unit and/or wiring diagram will be marked “Use Copper Conductors Only”. These instructions **must be** adhered to. Refer to the National Electrical Code (NEC) for complete current carrying capacity data on the various insulation grades of wiring material. All wiring must conform to NEC and all local codes.

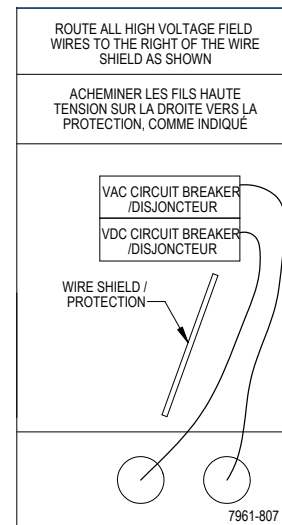
The electrical data lists fuse and wire sizes (75°C copper) for all models including the most commonly used heater sizes. Also shown are the number of field power circuits required for the various models with heaters.

The unit rating plate lists a “Maximum Time Delay Relay Fuse” or circuit breaker that is to be used with the equipment. The correct size must be used for proper circuit protection and also to assure that there will be no nuisance tripping due to the momentary high starting current of the compressor motor.

Route all field wires to the right of the wire shield as shown in the circuit routing label found in Figure 1.8 (and also on the wall-mount units).

Run communication wires in separate conduit whenever possible. If a unique installation occurs where it is not possible to isolate the communication wires, it is permissible to run communication wires in a conduit which contains a dedicated VDC voltage line. In all cases, the communication wires must be shielded, twisted wire and utilize proper filtration at the main communications board. **It is never permissible to run communication wires with VAC voltage lines.**

**FIGURE 1.8**  
**Circuit Routing Label**



See Figure 1.9 on page 17 to reference VAC and VDC supply wiring landing points.

**IMPORTANT:** 230/208V 1 phase and 3 phase equipment use dual primary voltage transformers. All equipment leaves the factory wired on 240V tap. **It is very important that the correct voltage tap is used.** For 208V operation, reconnect from 240V to 208V tap (see Figure 1.10). The acceptable operating voltage range for the 240 and 208V taps are: 240V Tap (253 – 216) and 208 Tap (220 – 197).

The disconnect access door on this unit may be locked to prevent unauthorized access to the disconnect. To convert for the locking capability, bend the tab located in the bottom left-hand corner of the disconnect opening under the disconnect access panel straight out. This tab will now line up with the slot in the door. When shut, a padlock may be placed through the hole in the tab preventing entry.

**TABLE 1.1  
Electrical Specifications**

| Model               | Rated Volts,<br>Hertz & Phase | AC POWER CIRCUIT               |   |                                     | DC POSITIVE GROUND POWER CIRCUIT |   |                                     |
|---------------------|-------------------------------|--------------------------------|---|-------------------------------------|----------------------------------|---|-------------------------------------|
|                     |                               | Minimum<br>Circuit<br>Ampacity | Maximum<br>External Fuse or<br>Ckt. Breaker | Field Power/<br>Ground Wire<br>Size | Minimum<br>Circuit<br>Ampacity   | Maximum<br>External Fuse<br>or Ckt. Breaker | Field Power/<br>Ground Wire<br>Size |
| D25A2PA0Z/D25L2PA0Z | 208/230-60-1                  | 19                             | 30  | 10/10                               | 15.6                             | 20  | 12                                  |
| D25A2PA05/D25L2PA05 | 208/230-60-1                  | 26                             | 30  | 8/10                                | 15.6                             | 20  | 12                                  |
| D35A2PA0Z/D35L2PA0Z | 208/230-60-1                  | 24                             | 40  | 8/10                                | 15.6                             | 20  | 12                                  |
| D35A2PA05/D35L2PA05 | 208/230-60-1                  | 26                             | 40  | 8/10                                | 15.6                             | 20  | 12                                  |
| D35A2PB0Z/D35L2PB0Z | 208/230-60-3                  | 19                             | 25  | 10/10                               | 15.6                             | 20  | 12                                  |
| D35A2PB06/D35L2PB06 | 208/230-60-3                  | 19                             | 25  | 10/10                               | 15.6                             | 20  | 12                                  |
| D28A2PA05/D28L2PA05 | 208/230-60-1                  | 26                             | 30  | 10/10                               | 15.6                             | 20  | 12                                  |
| D28A2PB06/D28L2PB06 | 208/230-60-3                  | 18                             | 20  | 12/12                               | 15.6                             | 20  | 12                                  |
| D36A2PA05/D36L2PA05 | 208/230-60-1                  | 26                             | 40  | 8/10                                | 15.6                             | 20  | 12                                  |
| D36A2PB06/D36L2PB06 | 208/230-60-3                  | 18                             | 25  | 10/10                               | 15.6                             | 20  | 12                                  |
| D42A2PA05/D42L2PA05 | 208/230-60-1                  | 26                             | 40  | 8/10                                | 15.6                             | 20  | 12                                  |
| D42A2PB06/D42L2PB06 | 208/230-60-3                  | 20                             | 25  | 10/10                               | 15.6                             | 20  | 12                                  |
| D48A2PA05/D48L2PA05 | 208/230-60-1                  | 30                             | 50  | 8/10                                | 15.6                             | 20  | 12                                  |
| D48A2PB06/D48L2PB06 | 208/230-60-3                  | 20                             | 30  | 10/10                               | 15.6                             | 20  | 12                                  |
| D60A2PA05/D60L2PA05 | 208/230-60-1                  | 36                             | 60  | 6/10                                | 15.6                             | 20  | 12                                  |
| D60A2PB06/D60L2PB06 | 208/230-60-3                  | 30                             | 40  | 8/10                                | 15.6                             | 20  | 12                                  |

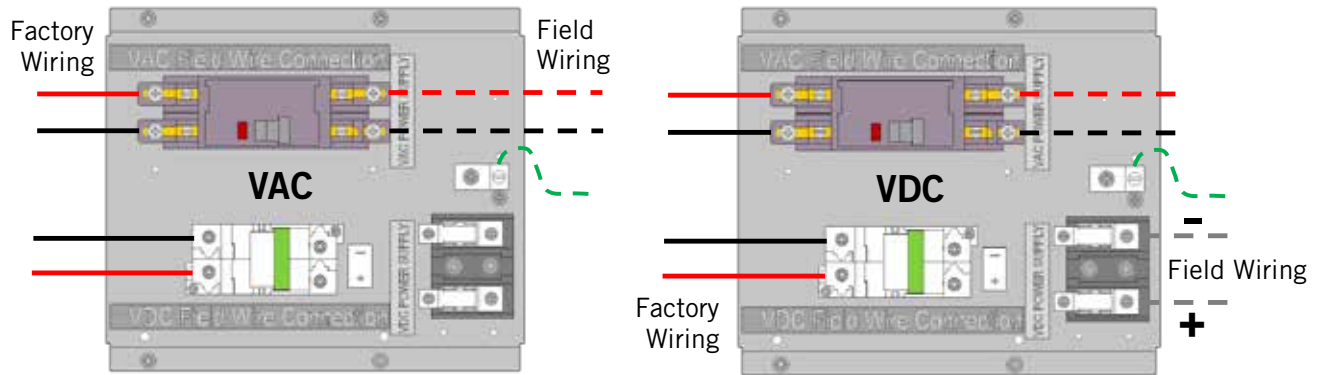
These "Minimum Circuit Ampacity" values are to be used for sizing the field power conductors. Refer to the National Electric Code (latest version), Article 310 for power conductor sizing.

**CAUTION:** When more than one field power circuit is run through one conduit, the conductors must be derated. Pay special attention to note 8 of Table 310 regarding Ampacity Adjustment Factors when more than three current carrying conductors are in a raceway.

Maximum size of the time delay fuse or circuit breaker for protection of field wiring conductors.  
Based on 75°C copper wire. All wiring must conform to the National Electric Code and all local codes.



**FIGURE 1.9**  
**VAC and VDC Supply Wiring Landing Points**



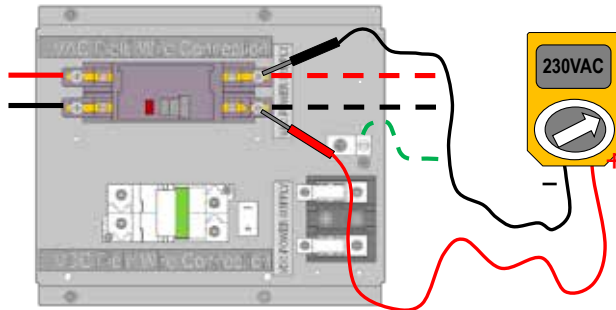
**NOTE:** Right-hand access model wiring landing points are shown here; left-hand access models will mirror this image.

**NOTE:** Right-hand access model wiring landing points are shown here; left-hand access models will mirror this image.

**FIGURE 1.10**  
**Adjusting the 230/208 VAC Transformer**

230V/208V 1 phase and 3 phase equipment use dual primary voltage transformers. All equipment leaves the factory wired on 240V tap. **It is very important that the correct voltage tap is used.** For 208V operation, reconnect from 240V to 208V tap. The acceptable operating voltage range for the 240 and 208V taps are: 240V Tap (253 – 216) and 208V Tap (220 – 197).

1. Verify incoming AC voltage: Multimeter set to VAC



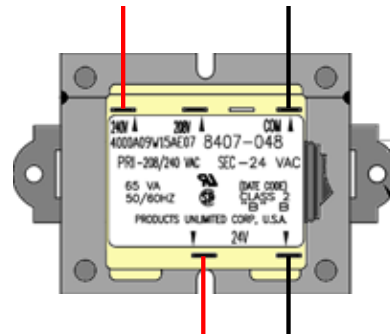
Shelter supply breaker in ON position  
 Bard system breaker in OFF position

230V/208V Single Phase Voltage Range:  
197VAC – 253VAC

230V/208V Three Phase Voltage Range:  
197VAC – 253VAC  
 (not shown)

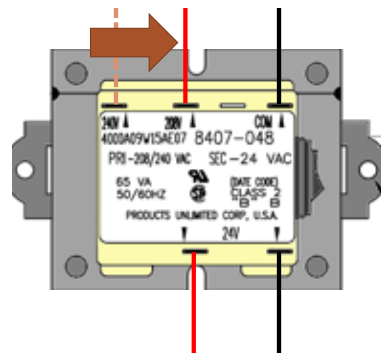
2. If incoming AC voltage is 220VAC or above...

...do not adjust transformer



3. If incoming AC voltage is below 220VAC...

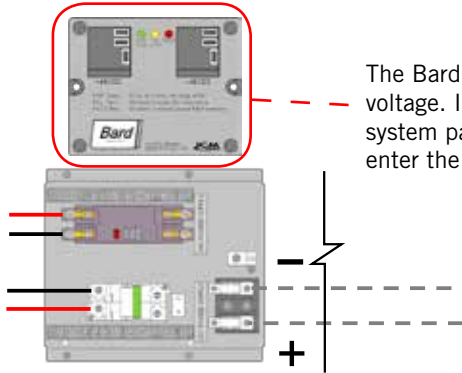
**...shut off AC breaker to unit**  
 and move factory "240V" wire to "208V" terminal



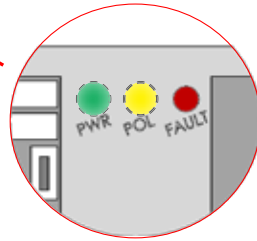
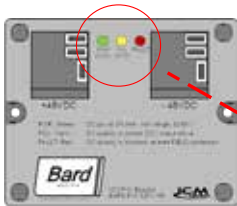
**FIGURE 1.11**  
**Bard Polarity-Voltage Monitor**



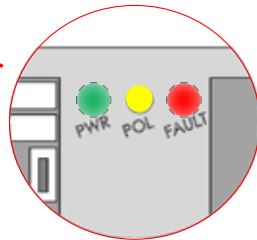
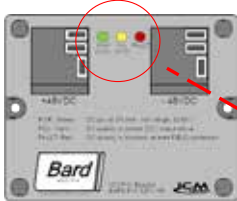
If the VDC wiring is not terminated correctly on the specific polarity-indicated terminals of the VDC terminal block, the VDC controls and motors will not activate and the wall-mounted unit will not function.



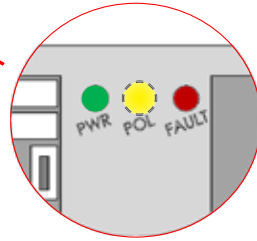
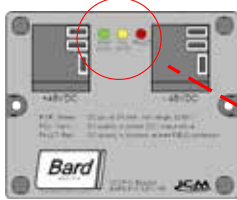
The Bard Polarity-Voltage Monitor continually monitors for correct polarity and voltage. If field wiring is connected improperly, or the voltage is outside of the system parameters, the Polarity-Voltage Monitor will not allow any VDC voltage to enter the system, protecting the internal controls and equipment.



When field wiring is correct in voltage and polarity, the green power (PWR) LED and yellow polarity (POL) LED will light, and system will operate normally.



If field wiring is incorrect in polarity, the red FAULT LED will light, and the monitor will not allow VDC voltage into the system.



If field wiring is correct in polarity but outside of the required 40VDC – 56VDC, the green PWR LED will not illuminate and the monitor not allow VDC voltage into the system.

If the Polarity-Voltage Monitor is showing a problem with polarity and/or voltage, see pages 41 and 42 of the Service section of this manual for instructions on checking VDC polarity and verifying incoming VDC voltage.

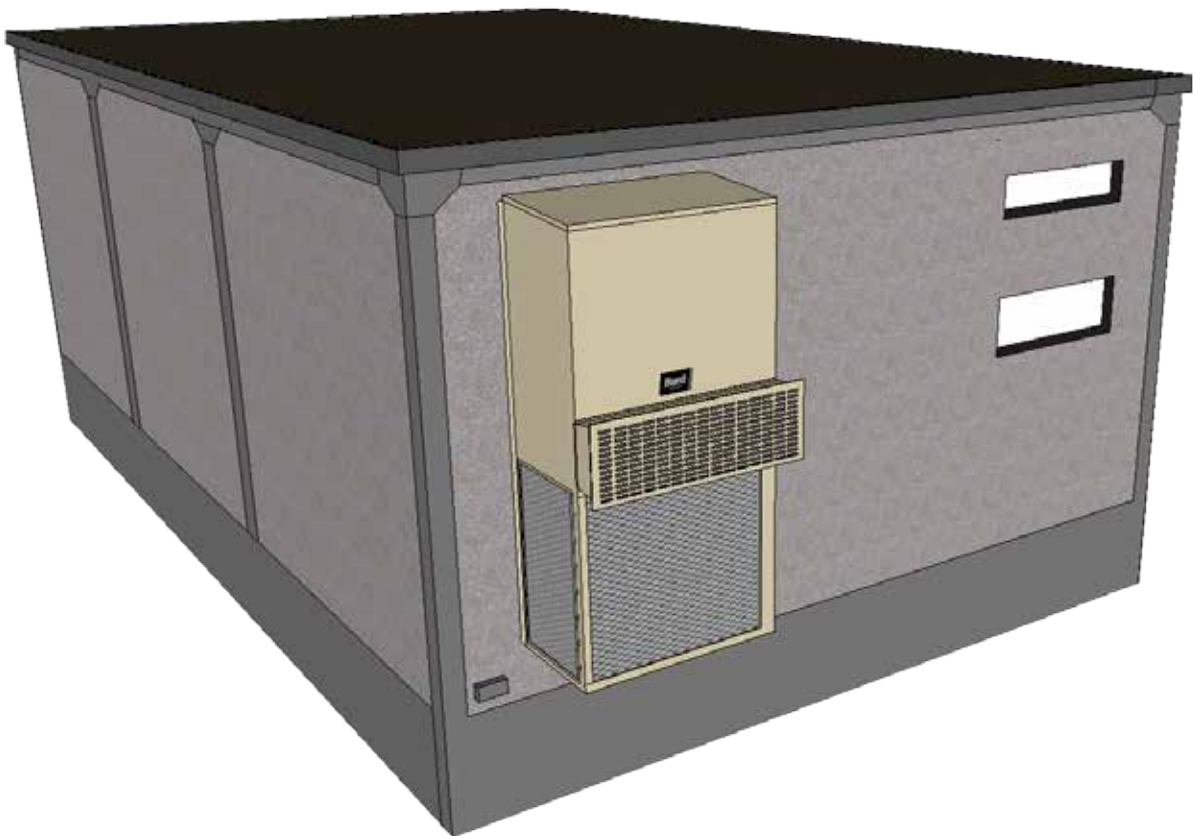
### **RUNNING IN STAND ALONE (ORPHAN) MODE**

With both AC and DC breakers turned on, each D-Series wall-mount system has the capability to run without the controller attached—this feature is called Stand Alone or Orphan Mode, and it basically keeps the shelter between 60°F and 78°F by the use of the factory-installed return air sensor in each wall-mount unit.

During installation, this allows deactivation of one of the two existing, older wall-mount units, while keeping the shelter cool with the other unit still operating. Once the first of the two Bard wall-mount units is installed, Orphan Mode can be enabled early in the installation—keeping the climate inside the shelter stable and the installers comfortable while the remainder of the older equipment is removed and the second Bard wall-mount unit and controller are installed.

Additionally, should either or both D-Series wall-mount units lose communication with the controller (such as during maintenance), they will continue to serve the shelter's needs until a repair can be made.

See the LC Series controller manual for information on connecting the communication wiring from the controller to the two wall-mount units and operating the DC free cooling unit system.





# **SECTION 2:**

# **SERVICE**

# **INSTRUCTIONS**

# GENERAL REFRIGERANT INFORMATION

## NOTICE

These units require R-410A refrigerant and polyol ester oil.

### GENERAL

1. Use separate service equipment to avoid cross contamination of oil and refrigerants.
2. Use recovery equipment rated for R-410A refrigerant.
3. Use manifold gauges rated for R-410A (800 psi/250 psi low).
4. R-410A is a binary blend of HFC-32 and HFC-125.
5. R-410A is nearly azeotropic—similar to R-22 and R-12. Although nearly azeotropic, charge with liquid refrigerant.
6. R-410A operates at 40-70% higher pressure than R-22, and systems designed for R-22 cannot withstand this higher pressure.
7. R-410A has an ozone depletion potential of zero, but must be reclaimed due to its global warming potential.
8. R-410A compressors use polyol ester oil.
9. Polyol ester oil is hygroscopic; it will rapidly absorb moisture and strongly hold this moisture in the oil.
10. A liquid line dryer must be used—even a deep vacuum will not separate moisture from the oil.
11. Limit atmospheric exposure to 15 minutes.
12. If compressor removal is necessary, always plug compressor immediately after removal. Purge with small amount of nitrogen when inserting plugs.

### TOPPING OFF SYSTEM CHARGE

If a leak has occurred in the system, Bard Manufacturing recommends reclaiming, evacuating (see criteria above) and charging to the nameplate charge. If done correctly, topping off the system charge can be done without problems.

With R-410A, there are no significant changes in the refrigerant composition during multiple leaks and recharges. R-410A refrigerant is close to being an azeotropic blend (it behaves like a pure compound or single component refrigerant). The remaining refrigerant charge in the system may be used after leaks have occurred. “Top-off” the charge by utilizing the pressure charts on the inner control panel cover as a guideline.

**REMEMBER:** When adding R-410A refrigerant, it must come out of the charging cylinder/tank as a liquid to avoid any fractionation and to insure optimal system performance. Refer to instructions for the cylinder that is being utilized for proper method of liquid extraction.

### SAFETY PRACTICES

1. Never mix R-410A with other refrigerants.
2. Use gloves and safety glasses. Polyol ester oils can be irritating to the skin, and liquid refrigerant will freeze the skin.
3. Never use air and R-410A to leak check; the mixture may become flammable.
4. Do not inhale R-410A—the vapor attacks the nervous system, creating dizziness, loss of coordination and slurred speech. Cardiac irregularities, unconsciousness and ultimately death can result from breathing this concentration.
5. Do not burn R-410A. This decomposition produces hazardous vapors. Evacuate the area if exposed.
6. Use only cylinders rated DOT4BA/4BW 400.
7. Never fill cylinders over 80% of total capacity.
8. Store cylinders in a cool area, out of direct sunlight.
9. Never heat cylinders above 125°F.
10. Never trap liquid R-410A in manifold sets, gauge lines or cylinders. R-410A expands significantly at warmer temperatures. Once a cylinder or line is full of liquid, any further rise in temperature will cause it to burst.

### R410-A REFRIGERANT CHARGE

This unit was charged at the factory with the quantity of refrigerant listed on the serial plate. AHRI capacity and efficiency ratings were determined by testing with this refrigerant charge quantity.

The pressure table found on the following page shows nominal pressures for the units. Since many installation specific situations can affect the pressure readings, this information should only be used by certified technicians as a guide for evaluating proper system performance. They shall not be used to adjust charge. If charge is in doubt, reclaim, evacuate and recharge the unit to the serial plate charge.

### PRESSURE SERVICE PORTS

High and low pressure service ports are installed on all units so that the system operating pressures can be observed. A pressure table covering all models can be found on page 23. It is imperative to match the correct pressure table to the unit by model number.

This unit employs high-flow Coremax valves instead of the typical Schrader type valves.

**WARNING! Do NOT use a Schrader valve core removal tool with these valves. Use of such a tool could result in eye injuries or refrigerant burns!**

To change a Coremax valve without first removing the refrigerant, a special tool is required which can be obtained at [www.fastestinc.com/en/SCCA07H](http://www.fastestinc.com/en/SCCA07H). See the replacement parts manual for replacement core part numbers.

**TABLE 2.1  
Nominal Pressures**

| Model  | Return Air Temperature | Pressure  | Air Temperature Entering Outdoor Coil, Degree °F |     |     |     |     |     |     |     |     |     | Capacitors |                        |
|--------|------------------------|-----------|--|-----|-----|-----|-----|-----|-----|-----|-----|-----|------------|------------------------|
|        |                        |           | 75   | 80  | 85  | 90  | 95  | 100 | 105 | 110 | 115 | 120 | Part No.   | Ratings                |
|        |                        |           |  |     |     |     |     |     |     |     |     |     |            |                        |
| D25A/L | 75° DB                 | Low Side  | 132  | 133 | 134 | 136 | 137 | 138 | 140 | 142 | 144 | 147 | 8552-050   | 1 Ø, 240V<br>40+15/370 |
|        | 62° WB                 | High Side | 292  | 308 | 327 | 347 | 369 | 392 | 417 | 445 | 474 | 505 |            |                        |
|        | 80° DB                 | Low Side  | 141  | 142 | 143 | 145 | 146 | 148 | 150 | 152 | 154 | 157 | 8552-002   | 3 Ø, 240V<br>5/370     |
| 67° WB | High Side              | 299       | 316  | 335 | 356 | 378 | 402 | 428 | 456 | 486 | 518 |     |            |                        |
| D28A/L | 75° DB                 | Low Side  | 137  | 137 | 137 | 139 | 140 | 141 | 143 | 144 | 146 | 148 | 8552-055   | 1 Ø, 240V<br>40+10/370 |
|        | 62° WB                 | High Side | 279  | 299 | 321 | 342 | 366 | 389 | 413 | 439 | 464 | 491 |            |                        |
|        | 80° DB                 | Low Side  | 146  | 146 | 147 | 149 | 150 | 151 | 153 | 154 | 156 | 158 | 8552-005   | 3 Ø, 240V<br>10/370    |
| 67° WB | High Side              | 286       | 307  | 329 | 351 | 375 | 399 | 424 | 450 | 476 | 504 |     |            |                        |
| D35A/L | 75° DB                 | Low Side  | 118  | 120 | 122 | 125 | 127 | 129 | 132 | 134 | 136 | 137 | 8552-052   | 1 Ø, 240V<br>45+15/370 |
|        | 62° WB                 | High Side | 327  | 349 | 371 | 396 | 421 | 448 | 475 | 504 | 533 | 565 |            |                        |
|        | 80° DB                 | Low Side  | 126  | 128 | 131 | 134 | 136 | 138 | 141 | 143 | 145 | 147 | 8552-002   | 3 Ø, 240V<br>5/370     |
| 67° WB | High Side              | 335       | 358  | 381 | 406 | 432 | 459 | 487 | 517 | 547 | 579 |     |            |                        |
| D36A/L | 75° DB                 | Low Side  | 133  | 135 | 137 | 138 | 139 | 141 | 143 | 145 | 147 | 149 | 8552-079   | 1 Ø, 240V<br>45+10/370 |
|        | 62° WB                 | High Side | 313  | 327 | 342 | 361 | 382 | 406 | 432 | 461 | 492 | 527 |            |                        |
|        | 80° DB                 | Low Side  | 142  | 144 | 146 | 148 | 149 | 151 | 153 | 155 | 157 | 159 | 8552-005   | 3 Ø, 240V<br>10/370    |
| 67° WB | High Side              | 321       | 335  | 351 | 370 | 392 | 416 | 443 | 473 | 505 | 540 |     |            |                        |
| D42A/L | 75° DB                 | Low Side  | 131  | 132 | 134 | 136 | 137 | 139 | 142 | 144 | 146 | 149 | 8552-079   | 1 Ø, 240V<br>45+10/370 |
|        | 62° WB                 | High Side | 315  | 331 | 348 | 368 | 388 | 410 | 435 | 461 | 489 | 520 |            |                        |
|        | 80° DB                 | Low Side  | 140  | 141 | 143 | 145 | 147 | 149 | 152 | 154 | 156 | 159 | 8552-005   | 3 Ø, 240V<br>10/370    |
| 67° WB | High Side              | 323       | 339  | 357 | 377 | 398 | 421 | 446 | 473 | 502 | 533 |     |            |                        |
| D48A/L | 75° DB                 | Low Side  | 133  | 136 | 137 | 139 | 141 | 142 | 144 | 145 | 147 | 148 | 8552-089   | 1 Ø, 240V<br>70+10/370 |
|        | 62° WB                 | High Side | 325  | 341 | 360 | 379 | 401 | 424 | 449 | 477 | 505 | 535 |            |                        |
|        | 80° DB                 | Low Side  | 142  | 145 | 147 | 149 | 151 | 152 | 154 | 155 | 157 | 158 | 8552-005   | 3 Ø, 240V<br>10/370    |
| 67° WB | High Side              | 333       | 350  | 369 | 389 | 411 | 435 | 461 | 489 | 518 | 549 |     |            |                        |
| D60A/L | 75° DB                 | Low Side  | 129  | 130 | 132 | 133 | 134 | 136 | 137 | 137 | 139 | 140 | 8552-058   | 1 Ø, 240V<br>80+10/440 |
|        | 62° WB                 | High Side | 353  | 362 | 374 | 390 | 410 | 432 | 458 | 488 | 522 | 559 |            |                        |
|        | 80° DB                 | Low Side  | 138  | 139 | 141 | 142 | 143 | 145 | 146 | 147 | 149 | 150 | 8552-005   | 3 Ø, 240V<br>10/370    |
| 67° WB | High Side              | 362       | 371  | 384 | 400 | 420 | 443 | 470 | 501 | 535 | 573 |     |            |                        |
| D60A/L | 85° DB                 | Low Side  | 143  | 144 | 146 | 147 | 148 | 150 | 151 | 152 | 154 | 155 | 8552-005   | 3 Ø, 240V<br>10/370    |
|        | 72° WB                 | High Side | 375  | 384 | 397 | 414 | 435 | 459 | 486 | 519 | 554 | 593 |            |                        |

Low Side Pressure ±4 PSIG  
High Side Pressure ±10PSIG

**FIGURE 2.1  
Refrigerant Sight Glass**

The refrigerant sight glass installed in this unit is not a charging indicator. The sight glass is for moisture reference only. If charge is in doubt, reclaim, evacuate and recharge the unit to the serial plate charge.



# SEQUENCE OF OPERATION

## D-SERIES WALL-MOUNT UNIT SEQUENCE OF OPERATION

### Overview

This product is designed to function like a typical telecom air conditioning system with an outdoor air-cooling damper. However, the DC Free Cooling Unit system does have some special features, like a control board which allows for advanced alarming and a “DC Free Cooling” feature that allows for forced emergency ventilated cooling anytime “shore power” VAC power from the utility company is lost. The internal controls within this unit automatically recognize a loss of shore power, energizing the indoor blower motor and powering the actuator to open the damper to bring in outdoor air. The power utilized during this time is the stored battery power from the equipment shelter.

### Indoor Blower

The indoor blower is a 48VDC motor, completely separate from the VAC circuit(s). For the blower to activate, two separate actions must take place:

1. 24VDC from terminal N07 (Blower Motor Start Relay)
2. 0-10VDC signal from terminal Y1 (Speed Voltage)

While the 24VDC from N07 will always stay the same, the 0-10VDC signal from terminal Y1 will vary depending upon the mode. See Table 2.2.

### DC Free Cooling Damper

This controller is enabled for dewpoint control, specifically examining the combination of temperature and relative humidity to determine the proper control of cooling. The system will utilize free cooling when the following conditions are true:

1. The outdoor temperature is below 70°F
2. The dewpoint of the outdoor air is below 60°F
3. The outdoor humidity is below 80% RH
4. The indoor humidity is below 60% RH

To signal the 24VDC damper actuator to open, a 2-10VDC signal must come from the Y2 terminal. Additionally, while other modes get only a single speed from the indoor blower, free cooling mode will get two: one for outdoor air temperature above 40°F (faster), and another for those below 40°F (slower). See Table 2.2.

### Cooling Call

When a call for cooling generates from the controller, the system will first determine which mode of cooling to employ based on the outdoor temperature, the outdoor humidity and the indoor temperature.

- If the outdoor temperature and humidity ratio are conducive to free cooling, the control board will send:
  1. 2-10VDC Signal from Y2 (Damper Signal)
    - Modulates damper to achieve 55°F at supply air temperature sensor
  2. 24VDC from terminal N07 (Blower Motor Start Relay)
  3. 0-10VDC signal from terminal Y1 (Speed Voltage)
- If the outdoor conditions are conducive to free cooling, but a 2nd stage cooling call is generated, the board will additionally add 24VAC signal from the N02 terminal to the CCM, activating the compressor. The damper will limit outdoor air to keep supply air temperature at 55°F.

**TABLE 2.2**  
**Blower Speed Voltage Chart**

| Model     | Blower Only                     | Free Cooling Mode<br>(CFM/VDC<br>Speed Voltage) | Free Cooling Mode<br>Below 40°F<br>(CFM/VDC<br>Speed Voltage) | Cooling<br>(CFM/VDC<br>Speed Voltage) | Electric Heat |
|-----------|---------------------------------|---|---|---------------------------------------|---------------|
| D25A/D25L | Same as<br>Free Cooling<br>Mode | 1500/6.0  | 900/2.0   | 900/2.0                               | 1100/4.0      |
| D28A/D28L |                                 |   | 800/2.8   | 1100/3.8                              | 1800/7.0      |
| D35A/D35L |                                 |   | 1100/3.0  | 1100/4.0                              | 1100/4.0      |
| D36A/D36L |                                 |   | 800/2.8   | 1100/3.8                              | 1800/7.0      |
| D42A/D42L |                                 |   | 950/3.1   | 1250/4.7                              | 1800/7.0      |
| D48A/D48L |                                 |   | 1100/3.8  | 1600/6.3                              | 1800/7.0      |
| D60A/D60L |                                 |   | 1100/3.8  | 1600/6.3                              | 1800/7.0      |



- If conditions outside are not conducive to free cooling, the control board will send:
  1. 24VAC signal from NO2 to CCM (Compressor)
  2. 24VDC from terminal NO7 (Blower Motor Start Relay)
  3. 0-10VDC signal from Y1 (Speed Voltage)

### Heating Call

When a call for heating generates from the controller, the control board will send:

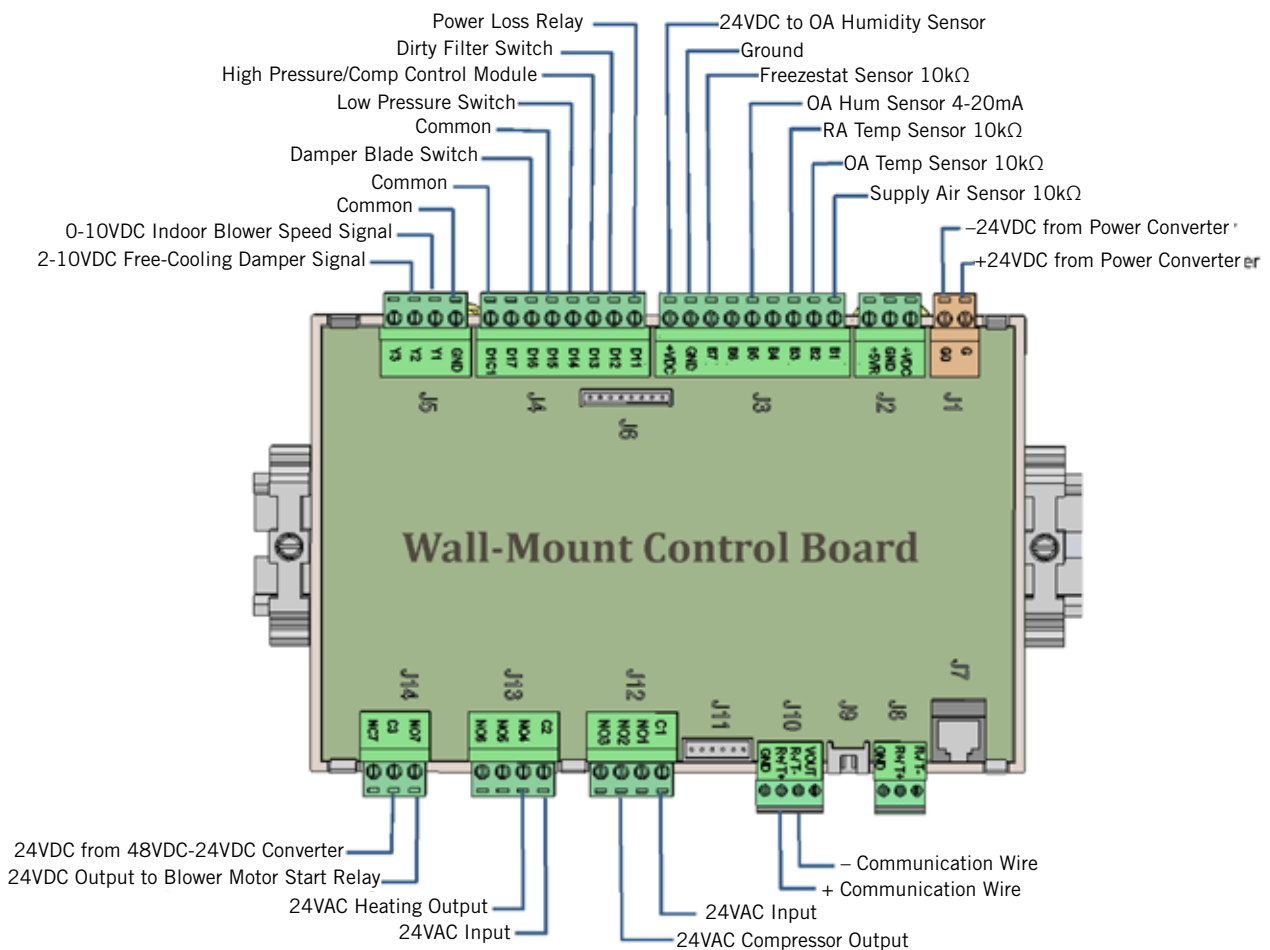
1. 24VAC signal from terminal NO4 to heat strip contactor.
2. 24VDC from terminal NO7 (Blower Motor Start Relay)
3. 0-10VDC signal from terminal Y1 (Motor Speed)

### Loss of Utility Power

When AC power is lost to the unit (no shore power, no generator), the AC power loss relay will send a digital input to terminal DI 1, alerting the board. If the temperature outside is warmer than the shelter internal temperature, the units will remain static. If the temperature outside is cooler than the internal temperature and there is a generated cooling call, the control board will send:

1. 2-10VDC Signal from terminal Y2 (Damper Signal)
  - Modulates damper to achieve 55°F at supply air temperature sensor
2. 24VDC from terminal NO7 (Blower Motor Start Relay)
3. 0-10VDC signal from terminal Y1 (Motor Speed)

**FIGURE 2.2**  
**Wall-Mount Unit Control Board**



### Special Considerations

- Compressor Run Time – Once activated, the compressor will run for a minimum of 5 minutes, regardless of setpoint (control board programming)
- Compressor Off Time – Once deactivated, the compressor will not start again for a minimum of 2 minutes.
- High Pressure Situation – The high pressure switch routes through the compressor control module (CCM), which allows one switch opening followed by a delay (soft lockout) of at least 2 minutes before trying again. If the switch is still open—or opens again on the same call—the CCM locks out the compressor and outdoor fan. Additionally, the CCM will send 24V to the high pressure alarm relay, which will then send a digital input to the DI 3 terminal.
- Low Pressure Situation – The low pressure switch is connected directly to DI 4:
  1. On a call for cooling, the board ignores the low pressure switch status for 2 minutes (OAT above 50°F) or 3 minutes (OAT below 50°F).
  2. If the switch is still open, the compressor will shut down and the controller will wait an additional 2 minutes.
  3. If the switch is still open, the controller will notify of an alarm and lock out the compressor. However, if the switch closes during this time, the compressor will start again and wait for 2 minutes (OAT above 50°F) or 3 minutes (OAT below 50°F).
  4. If the low pressure switch is open at this time, the compressor will lock out and the controller will notify of an alarm.
- High Temperature 2 Alarm – Should the shelter controller see 90°F, both free-cooling dampers will open (regardless of outdoor temperature) to cool the building.
- Smoke Alarm – Should the smoke detector send an alarm signal to the controller, all blower, compressor and ventilations functions cease.
- Hydrogen Alarm – Should the hydrogen detector send an alarm signal to the controller, both free cooling dampers will open (regardless of temperature) to dilute the shelter air.
- Freezestat – If the coil temperature is below 30°F for 120 seconds, the compressor will deactivate for 5 minutes, or until the sensor sees 55°F, whichever comes first.
- Generator Run – During generator operation, the system may limit compressor operation to only one unit providing that a specific jumper was removed from the LC controller terminal block and the alarm wires were connected to a generator-run relay (please refer to the Installation section of this manual regarding alarms and wiring).

**FIGURE 2.3**  
TEC-EYE™ Display



**ALARM KEY**

Allows viewing of active alarms  
Silences audible alarms  
Resets active alarms

**MENU KEY**

Allows entry to Main Menu

**ESCAPE KEY**

Returns to previous menu level  
Cancels a changed entry

**UP KEY**

Steps to next screen in the display menu  
Changes (increases) the value of a modifiable field

**ENTER KEY**

Accepts current value of a modifiable field  
Advances cursor

**DOWN KEY**

Steps back to previous screen in the display menu  
Changes (decreases) the value of a modifiable field

**TEC-EYE™ HAND-HELD DIAGNOSTIC TOOL**

The microprocessor control used in this wall mount air conditioning system allows for complete control and monitoring through the use of the provided TEC-EYE™ hand-held monitor. This comprehensive service tool utilizes the latest in state-of-the-art technology including a large, easy-to-read backlit LCD graphic display.

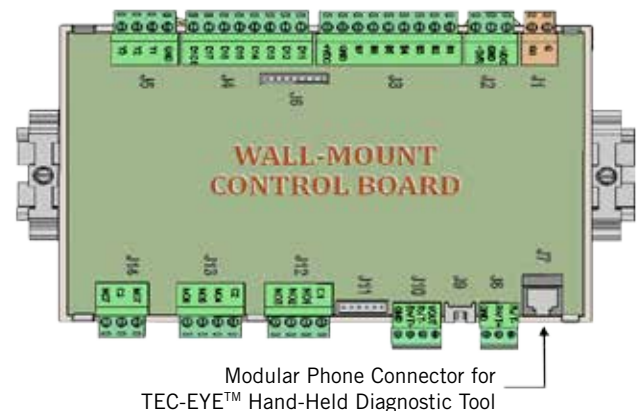
The menu driven interface provides users the ability to scroll through three menu levels: Info, Control and Service. The menus permit the user to easily view, control and configure the unit.

The controller is completely programmed at the factory; therefore, most applications will require no field set-up. However, the default setpoints and their ranges are easily viewed and adjusted from the TEC-EYE™ display. The program and operating parameters are permanently stored on FLASH-MEMORY in case of power failure. The controller is designed to manage temperature levels to a user-defined setpoint via control output signals to the wall mount air conditioning system.

The TEC-EYE™ connects to the wall-mount unit control board via an RJ11 modular phone connector as shown in Figure 2.4.

The TEC-EYE™ hand-held diagnostic tool should be stored somewhere inside the shelter, preferably close to the controller. The TEC-EYE™ has integrated magnets on the back of the tool, so it can be attached to the front, sides, bottom or top of the control box.

**FIGURE 2.4**  
TEC-EYE™ Connection to Unit Control



## TEC-EYE™ Menu Structure

- On/Off Unit
- Setpoints
- Clock/Scheduler
- Input/Output
  - Analog Inputs
  - Digital Inputs
  - Relay Outputs
  - Analog Outputs
- Alarm History
- Technician
  - Information
  - Working Hours
  - Service Settings
    - Control Loops
    - Probe Adjustment
  - Manual Management
    - Analog Inputs
    - Digital Inputs
    - Relay Outputs
    - Analog Outputs
- Factory
  - Configuration
  - I/O Configuration
  - Factory Settings

In addition to the menu structure above, there are also Status and Alarm screens.

## TEC-EYE™ Acronyms

SAT – Supply air temperature  
RAT – Return air temperature  
OAT – Outdoor air temperature  
OAH – Outdoor air humidity  
Sp – Temperature setpoint  
Space – Space temperature  
U1 – Unit 1  
U2 – Unit 2  
F – Indoor blower status  
D – DC free cooling damper position status  
EM – Emergency ventilation mode  
C1 – Compressor activate status  
HT – Heater status  
OA Dew Point – Calculated outdoor dew point  
FC – DC free cooling status  
RN – Component run time in minutes in last hour  
ST – Number of start requests in last hour

Press the MENU key to access the Main Menu screen. Press the UP or DOWN keys to scroll through the available menus. When the desired menu is highlighted, press the ENTER key to access that menu. Press the ESCAPE key or MENU key to return to the STATUS screen from the Main Menu.

## Status Screen

The STATUS screen is the default start-up screen and also the return screen after 5 minutes of no activity. The screen can be accessed any time by pressing the ESCAPE button repeatedly.

The STATUS screen displays the current date, time, return air temperature, supply air temperature, outdoor air temperature, outdoor humidity and dewpoint conditions. It also indicates the current system operating status for Unit 1 (U1) or Unit 2 (U2). The screen displays whether the blower is off or on and what percentage the damper is open.

**FIGURE 2.5**  
**TEC-EYE™ Status Display**



For the following items, press the MENU key to access programming.

## Executing a Run Test

Execute a run test on each unit to verify the equipment is functioning correctly.

1. Go to Technician menu, press ENTER key.
2. Press UP or DOWN arrow keys to get to Service Settings menu, press ENTER key.
3. Press UP or DOWN arrow keys to get to Control Loops menu, press ENTER key.
4. Cursor will be flashing in upper left corner of screen. Press DOWN arrow key to scroll through screens to Run Test.
5. Press ENTER key to scroll to Enable. Press UP or DOWN arrow keys to change No to Yes. Unit will begin the run test.

## Run Test Approximate Timings (in Minutes)

|            |                     |
|------------|---------------------|
| Blower     | On: 0:00            |
| Damper     | Open: 0:00 – 2:40   |
|            | Closed: 2:41 – 4:57 |
| Compressor | On: 4:58            |
|            | Off: 6:00           |
| Heat       | On: 6:01            |
|            | Off: 7:10           |
| Blower     | Off: 8:19           |

### Identifying a Unit Address

1. Go to Setpoints menu, press ENTER key.
2. Press UP or DOWN arrow keys to get to Fieldbus Address, press ENTER key. The wall-mount unit's current address value will display.

**NOTE:** This value can be changed if there was an error with the Auto Address sequence or the user would like to manually set the address of the unit.

### Manual Override Outputs

#### Blower

1. Go to Technician menu, press ENTER key.
2. Go to Manual Management, press ENTER key.
3. Go to Relay Outputs, press the DOWN arrow to get to Blower Relay Output. Move the cursor to the selected choice by pressing the ENTER key. Press UP or DOWN arrow keys to change the Manual Relay and Manual Position to "ON."
4. Press ESCAPE key, go to Analog Outputs.
5. Go to Blower Motor Analog Output, press Enter key to move the cursor to Mode. Change to Hand by pressing the UP arrow key. Press ENTER key. Next change the Manual Value to test blower speed voltage for the unit model and press ENTER key. Refer to the unit blower speed voltages provided in Table 2.6 on page 40; do not exceed the maximum speed voltage (VDC) for the unit model.

#### DC Free Cooling Damper

1. Go to Technician menu, press ENTER key.
2. Go to Manual Management, press ENTER key.
3. Go to Analog Outputs, press ENTER key.
4. Press DOWN arrow key to scroll screens to Analog Output 2 Damper.
5. Press ENTER key to scroll to Mode line. Press DOWN key to change Auto to Hand.

6. Press ENTER key to scroll to Manual Value line; Press UP or DOWN arrow keys to change the manual value to a desired value (maximum is 10VDC) to perform damper test.
7. Verify damper operation.

#### Compressor

1. Go to Technician menu, press ENTER key.
2. Go to Manual Management, press ENTER key.
3. Go to Relay Output, press ENTER key.
4. Go to Relay Output Cooling Stage. Press UP or DOWN arrow keys to change Manual Relay to "ON"; press ENTER key. Press UP or DOWN arrow keys to change manual position to "ON" and press ENTER key.
5. Verify compressor is running.

#### Heat

1. Go to Technician menu, press ENTER key.
2. Go to Manual Management, press ENTER key.
3. Go to Relay Output, press ENTER key.
4. Go to Relay Output Heating, press ENTER key.
5. Press UP or DOWN arrow keys to change Manual Relay and Manual Position to "ON" and press ENTER key.
6. Verify heater "ON" status.

## CAUTION

The Bard DC Free Cooling Unit System has been pre-programmed with what is widely considered to be the best settings for efficiency and operation. Any changes to internal programming through the LC Series Controller or the TEC-EYE™ not covered within this manual may cause the systems to operate improperly, cause internal damage to the HVAC units, cause the shelter to overheat or other very serious consequences. Although complete controller programming architecture for both the LC Controller and TEC-EYE™ has been provided, going outside the boundaries of what has been covered in this manual is not recommended.

# COMPONENTRY SPECIFICATIONS

## **WARNING**

**Electrical shock hazard.**

**Disconnect both VAC and VDC power supplies before servicing.**

**Failure to do so could result in electric shock or death.**

### **LOW PRESSURE SWITCH**

Cut-out pressure: 40psi (+/- 4 psi)

Cut-in pressure: 55psi (+/- 4psi)

### **HIGH PRESSURE SWITCH**

Cut-out pressure: 650psi (+/- 10 psi)

Cut-in pressure: 520psi (+/- 15psi)

### **LOW AMBIENT CONTROL**

Modulating head-pressure control that allows full speed at pressures above 315psi. Below 315psi, the control will slow fan speed—following internal head pressures—until a minimum RPM is reached (approx 300 RPM). Below this point, the control will shut the fan completely off until internal pressures rise. The control is preset from the factory, but should adjustment become necessary, there is an adjustment screw located on the bottom of the control behind a weatherproof cap. One full turn clockwise equals approximately +48 psi.

### **REMOTE INDOOR TEMPERATURE SENSOR**

White, decorative plastic casing, Bard logo, field-installed in shelter: 10k ohm resistance, see Table 2.3.

### **DISCHARGE TEMP SENSOR**

4.75" stainless probe factory mounted in supply opening of wall-mount unit: 10k ohm resistance, see Table 2.3.

### **RETURN TEMPERATURE SENSOR**

Exposed thermistor-element style with copper-coated steel clip, attached in return opening of wall-mount unit: 10k ohm resistance, see Table 2.3.

### **EVAPORATOR TEMP SENSOR (FREEZESTAT)**

Exposed thermistor-element style with copper-coated steel clip, attached to evaporator coil of wall-mount unit: 10k ohm resistance, see Table 2.3.

### **OUTDOOR TEMPERATURE/HUMIDITY SENSOR**

Gray, weather-proof octagonal case with dip tube, located in condenser section of wall-mount unit.

- Temperature sensor: 10k ohm resistance, see Table 2.3.
- Humidity sensor: 4-20mA.

### **COMPRESSOR CONTROL MODULE**

Compressor protection device that has an adjustable 30-second to 5-minute timer (red-dial). This module features a delay-on-make for initial start-up (or anytime power is interrupted) for a minimum 2 minutes plus 10% of the red-dial setting. There is no delay during routine operation of the unit. The compressor control module (CCM) also monitors the high pressure switch, and will allow one automatic retry (after soft lockout delay) before disabling the compressor in a hard lockout (requires manual reset). If hard lockout does occur, the ALR terminal on the CCM will become active with 24V, which will power the high pressure relay within the wall-mount unit, breaking a digital input to the control board—signaling a high-pressure situation to the system.

### **PHASE MONITOR**

Used only on 3-phase equipment, the phase monitor is a compressor protection device that will prohibit operation of the compressor if the device senses a possible reverse-rotation situation due to incorrect phasing. On a call for compressor (and only compressor), the device will check incoming phase, check for severe voltage imbalance and check for proper frequency. Under nominal conditions, a green LED light will show on the face of the monitor. If there is improper phasing, voltage imbalance or frequency deviation, the device will show a red LED light and prohibit compressor operation.

### **TRANSFORMER**

75VA with external 4A circuit breaker, 230VAC/208VAC convertible. Directly feeds power loss relay in wall-mount unit during normal operation. Should loss of utility power occur, transformer failure or transformer external circuit breaker open, the loss of VAC power will cause the contacts within the power loss relay to open, interrupting a digital input to the control board—signaling a loss-of-power situation to the system.

**TABLE 2.3**  
**Temperature (F) vs. Resistance (R) of Temperature Sensor**

| F     | R      | F    | R     | F    | R     | F     | R    |
|-------|--------|------|-------|------|-------|-------|------|
| -25.0 | 196871 | 13.0 | 56985 | 53.0 | 19374 | 89.0  | 7507 |
| -24.0 | 190099 | 14.0 | 55284 | 52.0 | 18867 | 90.0  | 7334 |
| -23.0 | 183585 | 15.0 | 53640 | 53.0 | 18375 | 91.0  | 7165 |
| -22.0 | 177318 | 16.0 | 52051 | 54.0 | 17989 | 92.0  | 7000 |
| -21.0 | 171289 | 17.0 | 50514 | 55.0 | 17434 | 93.0  | 6840 |
| -20.0 | 165487 | 18.0 | 49028 | 56.0 | 16984 | 94.0  | 6683 |
| -19.0 | 159904 | 19.0 | 47590 | 57.0 | 16547 | 95.0  | 6531 |
| -18.0 | 154529 | 20.0 | 46200 | 58.0 | 16122 | 96.0  | 6383 |
| -17.0 | 149355 | 21.0 | 44855 | 59.0 | 15710 | 97.0  | 6239 |
| -16.0 | 144374 | 22.0 | 43554 | 60.0 | 15310 | 98.0  | 6098 |
| -15.0 | 139576 | 23.0 | 42295 | 61.0 | 14921 | 99.0  | 5961 |
| -14.0 | 134956 | 24.0 | 41077 | 62.0 | 14544 | 100.0 | 5827 |
| -13.0 | 130506 | 25.0 | 39898 | 63.0 | 14177 | 101.0 | 5697 |
| -12.0 | 126219 | 26.0 | 38757 | 64.0 | 13820 | 102.0 | 5570 |
| -11.0 | 122089 | 27.0 | 37652 | 65.0 | 13474 | 103.0 | 5446 |
| -10.0 | 118108 | 28.0 | 36583 | 66.0 | 13137 | 104.0 | 5326 |
| -9.0  | 114272 | 29.0 | 35548 | 67.0 | 12810 | 105.0 | 5208 |
| -8.0  | 110575 | 30.0 | 34545 | 68.0 | 12492 | 106.0 | 5094 |
| -7.0  | 107010 | 31.0 | 33574 | 69.0 | 12183 | 107.0 | 4982 |
| -6.0  | 103574 | 32.0 | 32634 | 70.0 | 11883 | 108.0 | 4873 |
| -5.0  | 100260 | 33.0 | 31723 | 71.0 | 11591 | 109.0 | 4767 |
| -4.0  | 97064  | 34.0 | 30840 | 72.0 | 11307 | 110.0 | 4663 |
| -3.0  | 93981  | 35.0 | 29986 | 73.0 | 11031 | 111.0 | 4562 |
| -2.0  | 91008  | 36.0 | 29157 | 74.0 | 10762 | 112.0 | 4464 |
| -1.0  | 88139  | 37.0 | 28355 | 75.0 | 10501 | 113.0 | 4367 |
| 0.0   | 85371  | 38.0 | 27577 | 76.0 | 10247 | 114.0 | 4274 |
| 1.0   | 82699  | 39.0 | 26823 | 77.0 | 10000 | 115.0 | 4182 |
| 2.0   | 80121  | 40.0 | 26092 | 78.0 | 9760  | 116.0 | 4093 |
| 3.0   | 77632  | 41.0 | 25383 | 79.0 | 9526  | 117.0 | 4006 |
| 4.0   | 75230  | 42.0 | 24696 | 80.0 | 9299  | 118.0 | 3921 |
| 5.0   | 72910  | 43.0 | 24030 | 81.0 | 9077  | 119.0 | 3838 |
| 6.0   | 70670  | 44.0 | 23384 | 82.0 | 8862  | 120.0 | 3757 |
| 7.0   | 68507  | 45.0 | 22758 | 83.0 | 8653  | 121.0 | 3678 |
| 8.0   | 66418  | 46.0 | 22150 | 84.0 | 8449  | 122.0 | 3601 |
| 9.0   | 64399  | 47.0 | 21561 | 85.0 | 8250  | 123.0 | 3526 |
| 10.0  | 62449  | 48.0 | 20989 | 86.0 | 8057  | 124.0 | 3452 |
| 11.0  | 60565  | 49.0 | 20435 | 87.0 | 7869  |       |      |
| 12.0  | 58745  | 50.0 | 19896 | 88.0 | 7686  |       |      |

**BATTERIES**

Used in wall-mount unit and controller boards, flat-disk style BR2330 3V battery. Used only for time/date during complete power loss. Estimated lifespan 7-8 years.

**48VDC TO 24VDC POWER CONVERTER**

Used in both wall-mount units and LC-Series controller to change shelter-provided 48VDC to 24VDC power for control boards, relays, smoke detector and hydrogen detector: Phoenix Quint PS-Series. **NOTE: Output must be minimum 22.8 VDC to allow proper control board operation.**

## OUTDOOR FAN MOTOR

Due to design considerations of the condenser section of the wall-mount unit, placement/clearance of the motor/fan blade is critical to heat dispersal. Should a change of motor or fan blade be necessary, please view Figure 2.6 for proper clearance adjustment.

## DIRTY FILTER SWITCH

Located inside the blower compartment, this switch measures air pressure differential across the filter (see Figure 2.7). Manual reset only. Default setting: 0.8" static, 50% blocked filter (approximately).

## INDOOR BLOWER MOTOR

Unlike most other system fan motors, this motor is a 48VDC motor, and is very specialized in application. Please see Table 2.4 (blower table).

## PHOENIX ISOLATION RELAY: WALL-MOUNT UNIT

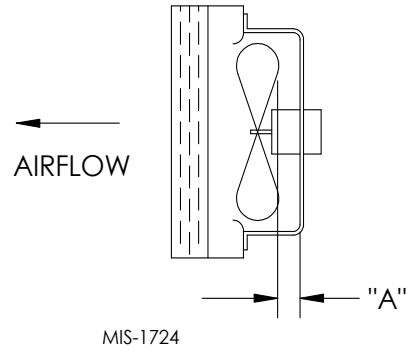
Green DIN-Rail mount isolation relay used in the wall-mount unit to isolate/filter 48VDC power, motor speed signal and ground from the control board: Phoenix Mini MCR-Style.

## ZETTLER ISOLATION RELAYS: WALL-MOUNT UNIT

Black Zettler surface mount relays used in the wall-mount unit to isolate the start signal from:

- Power loss relay circuit (see Figure 2.8)
- High pressure relay circuit (see Figure 2.9)
- Blower motor start signal relay circuit (see Figure 2.10)

**FIGURE 2.6**  
Fan Blade Setting



| Model                      | Dimension A |
|----------------------------|-------------|
| All covered by this manual | 1.75"       |

**FIGURE 2.7**  
Dirty Filter Switch



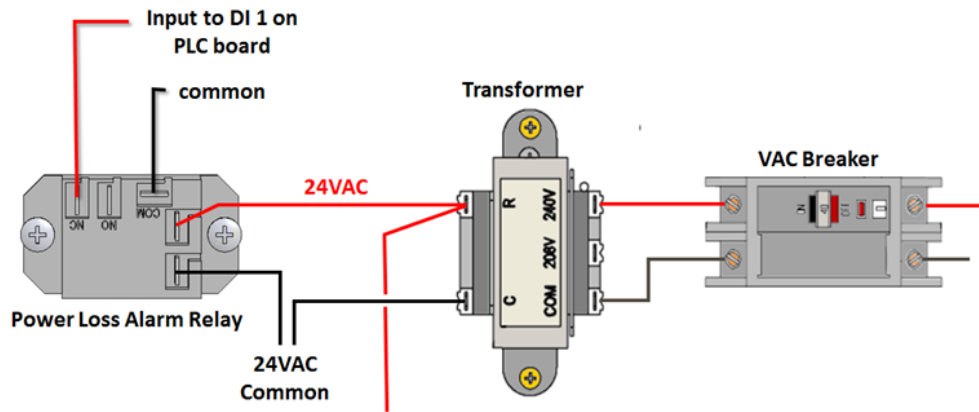
**TABLE 2.4**  
Indoor Blower Performance

| MODEL     | RATED ESP | MAX ESP | FREE COOLING CFM ABOVE 40° | FREE COOLING CFM BELOW 40°<br>① | RATED FULL LOAD COOLING CFM | ELECTRIC HEAT AIRFLOW |
|-----------|-----------|---------|----------------------------|---------------------------------|-----------------------------|-----------------------|
| D25A/D25L | 0.15      | 0.50    | 1500                       | 800                             | 800                         | 1100                  |
| D28A/D28L | 0.10      | 0.50    | 1800                       | 800                             | 1100                        | 1800                  |
| D35A/D35L | 0.15      | 0.50    | 1500                       | 800                             | 1100                        | 1100                  |
| D36A/D36L | 0.15      | 0.50    | 1800                       | 800                             | 1100                        | 1800                  |
| D42A/D42L | 0.20      | 0.50    | 1800                       | 950                             | 1250                        | 1800                  |
| D48A/D48L | 0.20      | 0.50    | 1800                       | 1100                            | 1600                        | 1800                  |
| D60A/D60L | 0.20      | 0.50    | 1800                       | 1100                            | 1600                        | 1800                  |

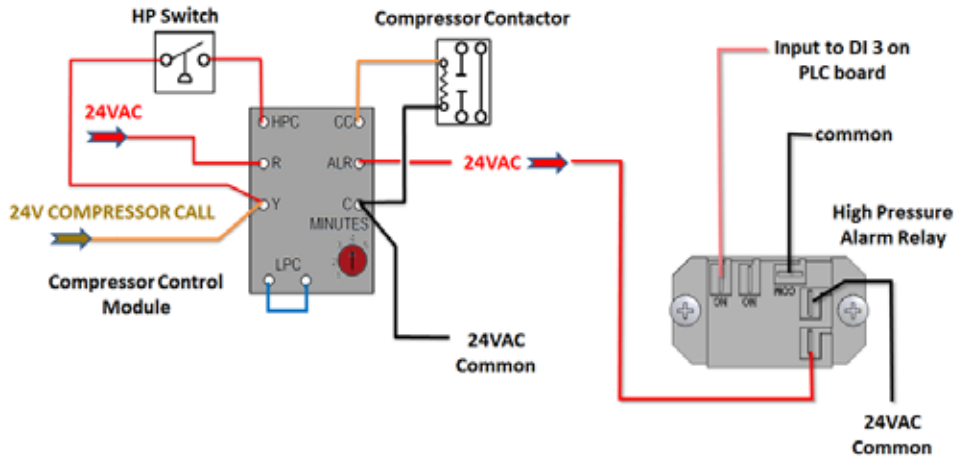
① LC Series controller derives at this decision point and switches the indoor motor speed. The damper actuator will then adjust to still yield a 55°F supply air temperature.



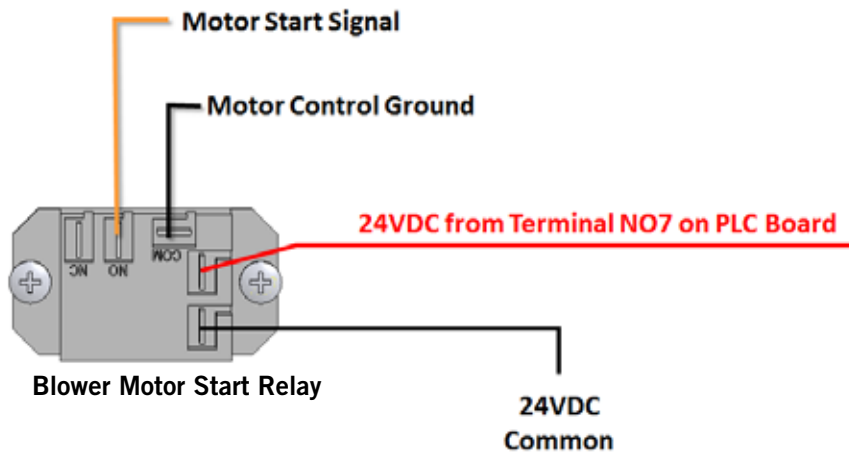
**FIGURE 2.8**  
Power Loss Relay Circuit



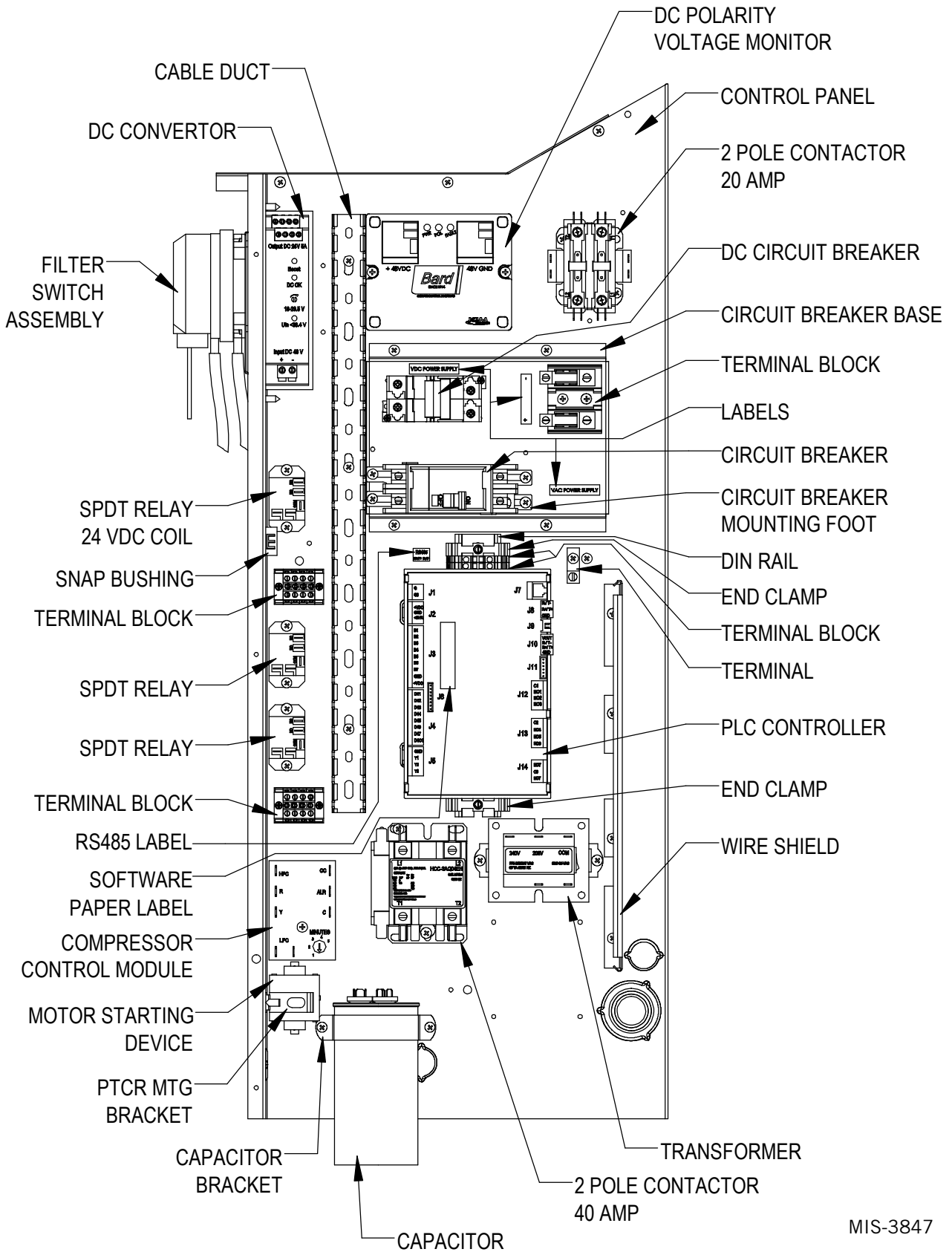
**FIGURE 2.9**  
High Pressure Relay Circuit



**FIGURE 2.10**  
Blower Motor Start Relay Circuit

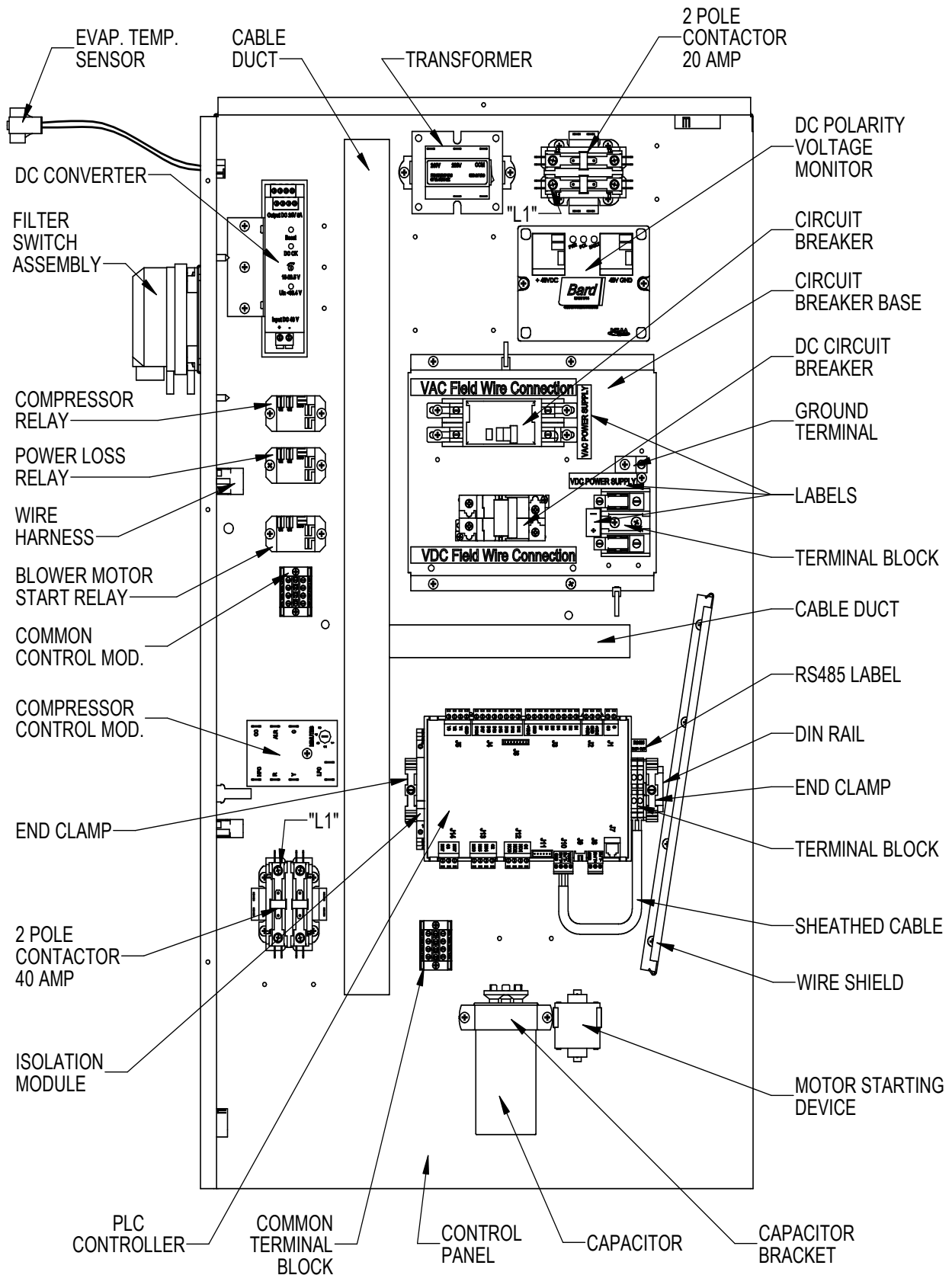


**FIGURE 2.11**  
**D25A/L, D35A/L Unit Control Panel**



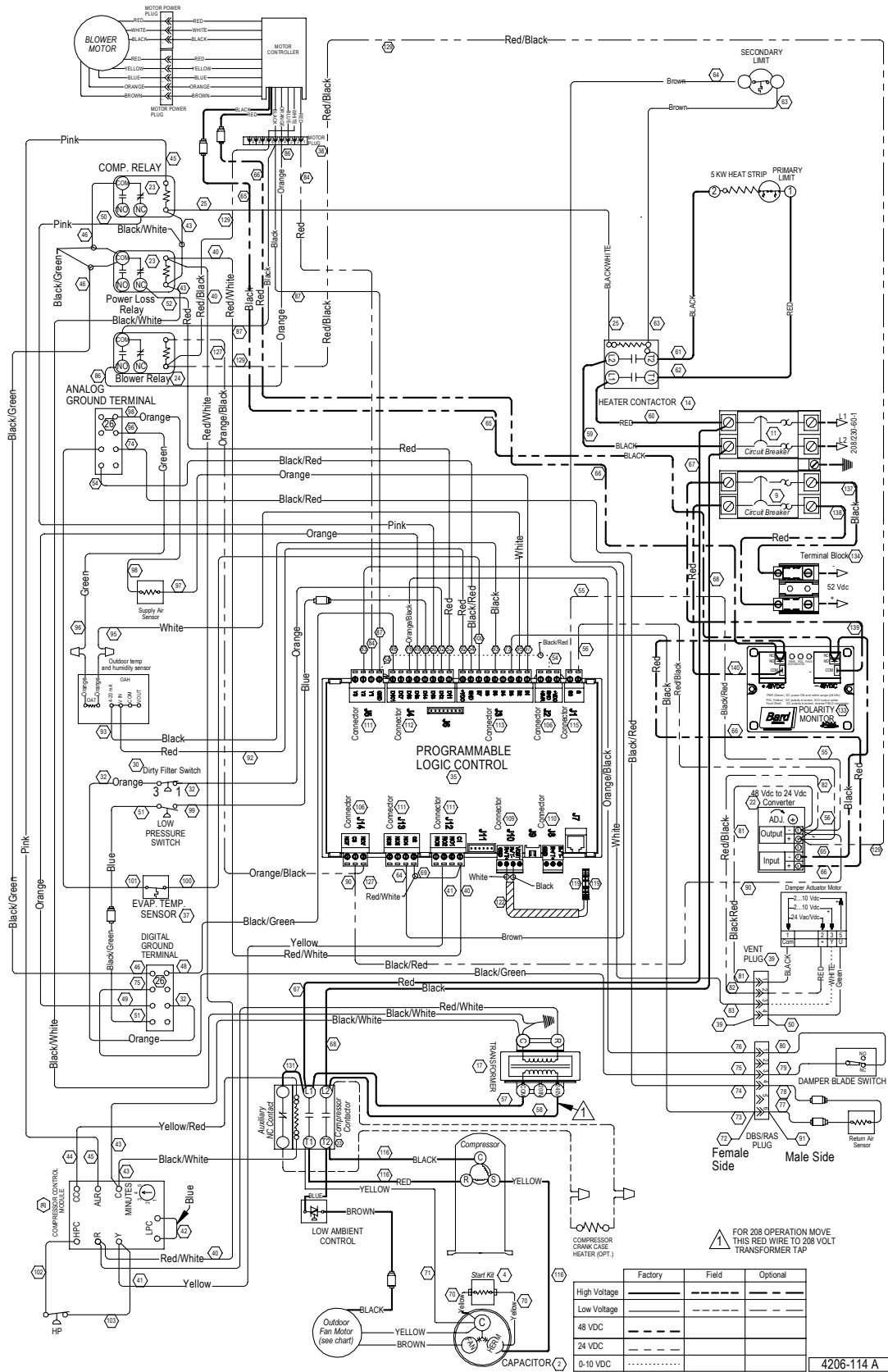
MIS-3847

**FIGURE 2.12**  
**D28A/L, D36A/L, D42A/L, D48A/L, D60A/L Unit Control Panel**

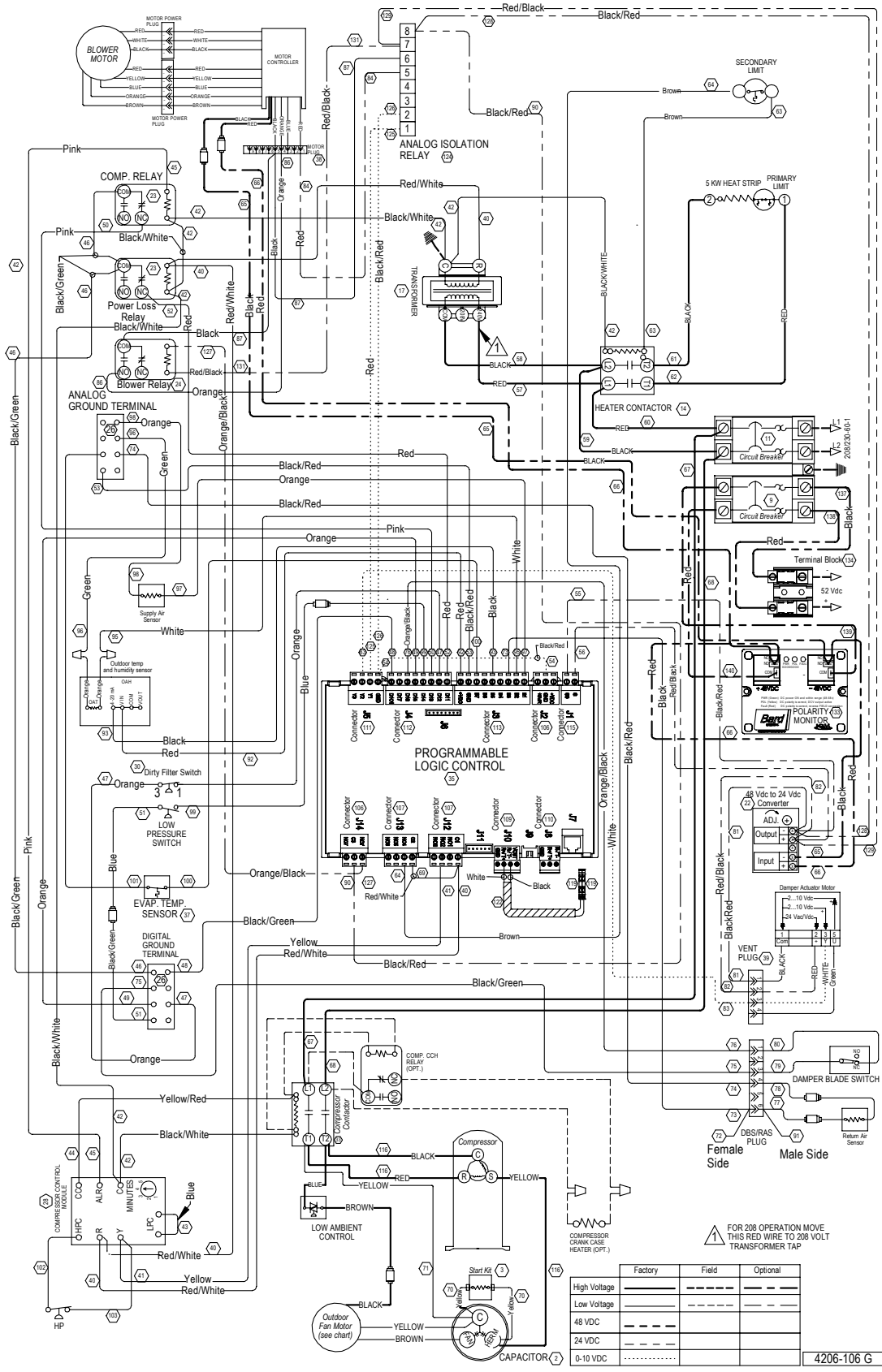


MIS-3671

**FIGURE 2.13**  
**D25A/L, D35A/L Unit Wiring Diagram**



**FIGURE 2.14**  
**D28A/L, D36A/L, D42A/L, D48A/L, D60A/L Unit Wiring Diagram**



# MAINTENANCE AND TROUBLESHOOTING

---

## STANDARD MAINTENANCE PROCEDURES

### **WARNING**

**Electrical shock hazard.**

**Disconnect both VAC and VDC power supplies before servicing.**

**Failure to do so could result in electric shock or death.**

### **CAUTION**

**Cut hazard.**

**Wear gloves to avoid contact with sharp edges.**

**Failure to do so could result in personal injury.**

1. Disable system from LC controller (see controller manual).
2. Turn off both AC and DC breakers at wall-mount units.
3. Check inlet sides of condenser and evaporator coils for obstructions/debris—clean if necessary using a quality manufactured coil cleaning product specific for the evaporator or condenser coil.
  - Condenser coil: Remove the fan shroud/motor/motor bracket as an assembly from the condenser section. This will give clear access to the inlet side of the coil for cleaning. Follow the coil cleaner manufacturer's directions for necessary safety gear and precautions, as well as for application and use. More than one application may be necessary. Rinse thoroughly.
  - Evaporator coil: Remove the evaporator section panel and apply specific evaporator cleaner directly to the inlet side of coil, being very careful not to overspray into insulation or surrounding panels and wiring. Residual cleaner and dissolved debris should drip into the drain pan and leave the unit through the condensate hose. More than one application may be necessary. Rinse thoroughly.
4. Manually spin fan and blower motors to ensure they turn freely. All motors are permanently lubricated, so no oil is necessary.
5. Inspect free cooling damper actuator and linkage.
6. Install new air filter; check for additional filter grilles internal to the structure.
7. Inspect the control panel of the system.
  - Look for insect or rodent activity and remove any nesting materials.
  - Manually push contactor closed, observe for movement—contactor points should have minimal discoloration, no spalling or other signs of arcing. Replace if doubtful.
  - Check field and factory wiring for tightness and look for signs of overheating (discoloration of terminals or wire insulation).
8. Ensure that supply and return registers are not obstructed, and more importantly, are not recycling the air to one another. Adjust supply louvers if necessary to direct discharge air away from any direct route to the return grille.
9. Re-assemble wall-mount unit and turn breakers back on.
10. Enable system from LC controller (see controller manual).
11. Repeat steps for second wall-mount unit.

## SPECIFIC TROUBLESHOOTING – 48VDC Blower Motor

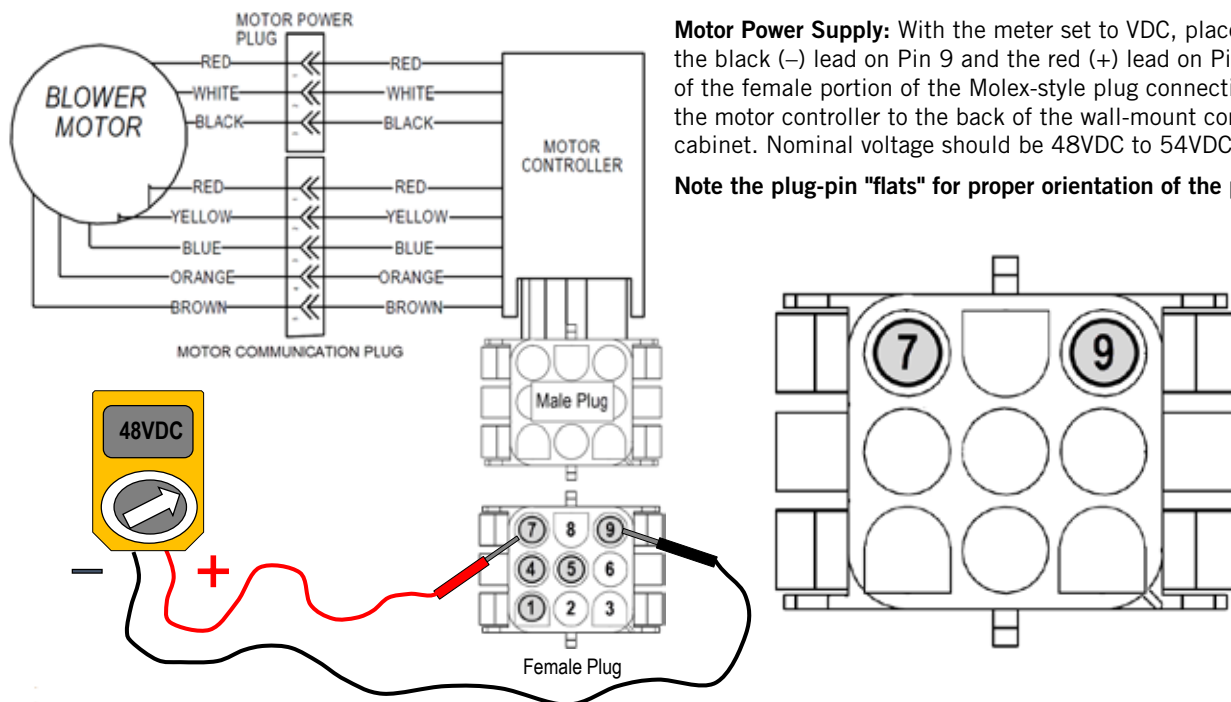
To troubleshoot the 48VDC blower motor, check for proper voltage and commands to the motor controller from the wall-mount unit. Under a command for blower,

disconnect the 9-pin Molex plug connecting the motor control to the wall-mount unit control wiring harness (this Molex is located in the chassis wall of the control panel) and test for the items in Table 2.5 (see Figure 2.15 below and Figures 2.16 and 2.17 on page 40).

**TABLE 2.5**  
**Troubleshooting the 48VDC Indoor Blower Motor**

| Motor Controller Molex Plug | Color  | Function       | Description of Application  |
|-----------------------------|--------|----------------|---|
| 1                           | Red    | SPEED INPUT    | 0-10 VDC input, varying voltage input between 0-10 VDC dictates the motor speed/CFM delivery                                    |
| 2                           |        |                |   |
| 3                           |        |                |   |
| 4                           | Orange | RUN            | Start Command – a contact closure between this wire and the control ground (Pin 5) will issue and order for the motor to start. |
| 5                           | Black  | CONTROL GROUND | Control Ground for both start-stop function and speed control voltage   |
| 6                           |        |                |   |
| 7                           | Red    | 52 VDC (+)     | "+" VDC power supplied to motor   |
| 8                           |        |                |   |
| 9                           | Black  | 52 VDC (-)     | "-" VDC power supplied to motor   |

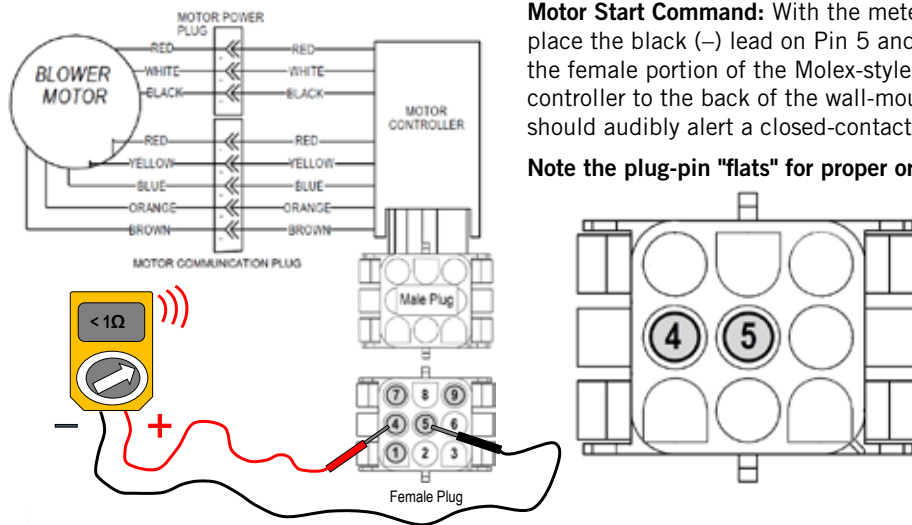
**FIGURE 2.15**  
**Troubleshooting Motor Power Supply**



**Motor Power Supply:** With the meter set to VDC, place the black (-) lead on Pin 9 and the red (+) lead on Pin 7 of the female portion of the Molex-style plug connecting the motor controller to the back of the wall-mount control cabinet. Nominal voltage should be 48VDC to 54VDC.

**Note the plug-pin "flats" for proper orientation of the plug.**

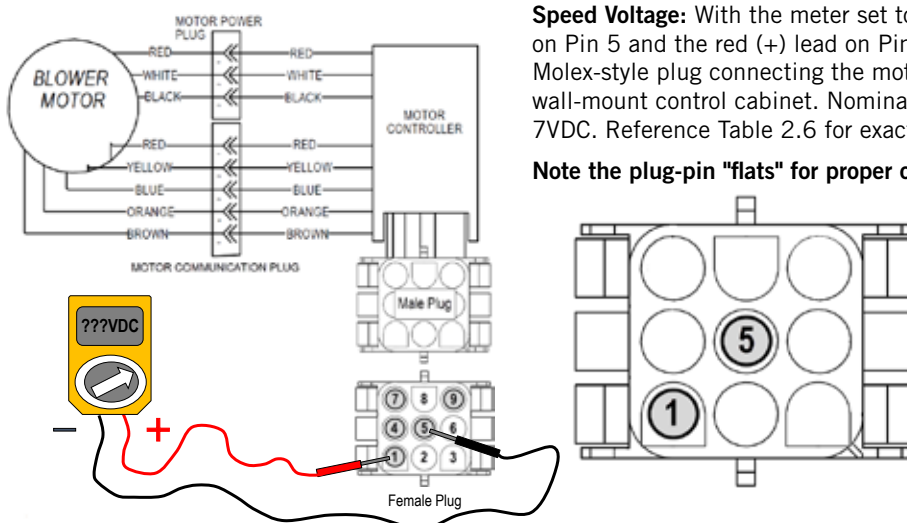
**FIGURE 2.16**  
**Troubleshooting Motor Start Command**



**Motor Start Command:** With the meter set to Continuity Beeper, place the black (-) lead on Pin 5 and the red (+) lead on Pin 4 of the female portion of the Molex-style plug connecting the motor controller to the back of the wall-mount control cabinet. Meter should audibly alert a closed-contact condition.

**Note the plug-pin "flats" for proper orientation of the plug.**

**FIGURE 2.17**  
**Troubleshooting Speed Voltage**



**Speed Voltage:** With the meter set to VDC, place the black (-) lead on Pin 5 and the red (+) lead on Pin 1 of the female portion of the Molex-style plug connecting the motor controller to the back of the wall-mount control cabinet. Nominal voltage should be 2.8VDC to 7VDC. Reference Table 2.6 for exact voltage.

**Note the plug-pin "flats" for proper orientation of the plug.**

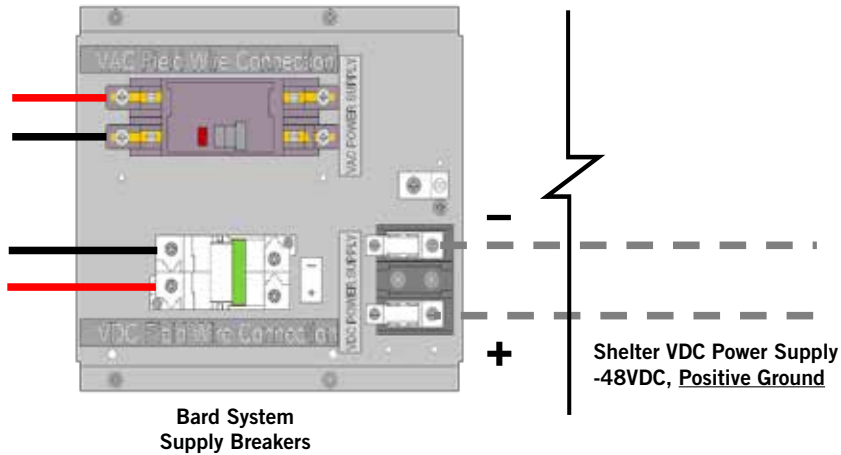
**TABLE 2.6**  
**Blower Speed Voltage Chart**

| Model     | Blower Only               | Free Cooling Mode (CFM/VDC Speed Voltage) | Free Cooling Mode Below 40°F (CFM/VDC Speed Voltage) | Cooling (CFM/VDC Speed Voltage) | Electric Heat |
|-----------|---------------------------|---|--|---------------------------------|---------------|
| D25A/D25L | Same as Free Cooling Mode | 1500/6.0                                  | 900/2.0  | 900/2.0                         | 1100/4.0      |
| D28A/D28L |                           |   | 800/2.8  | 1100/3.8                        | 1800/7.0      |
| D35A/D35L |                           |   | 1100/3.0   | 1100/4.0                        | 1100/4.0      |
| D36A/D36L |                           |   | 800/2.8  | 1100/3.8                        | 1800/7.0      |
| D42A/D42L |                           |   | 950/3.1  | 1250/4.7                        | 1800/7.0      |
| D48A/D48L |                           |   | 1100/3.8   | 1600/6.3                        | 1800/7.0      |
| D60A/D60L |                           |   | 1100/3.8   | 1600/6.3                        | 1800/7.0      |

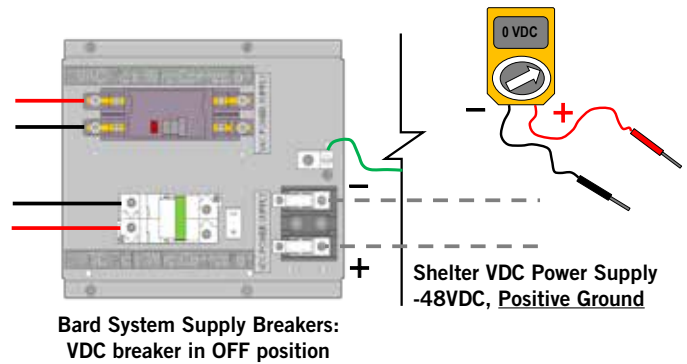


**FIGURE 2.18**  
**VDC Polarity Check**

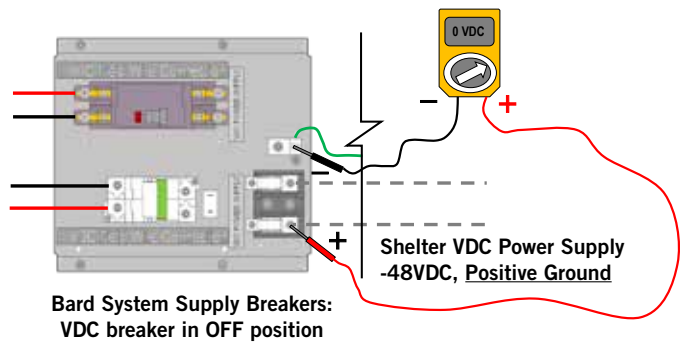
If the VDC wiring is not terminated correctly on the specific polarity-indicated terminals of the VDC terminal block, the VDC controls and motors will not activate and the wall-mounted unit will not function.



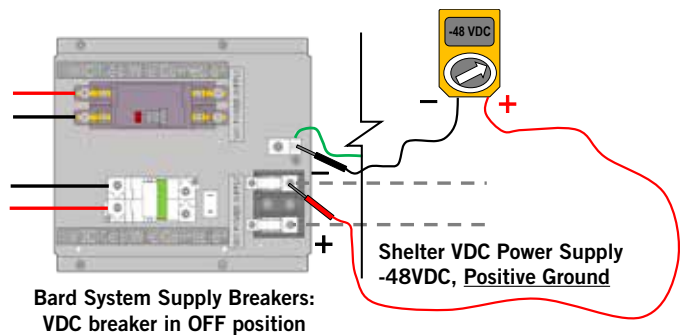
**Step 1**  
Multimeter set to VDC:  
Display reveals "0" voltage potential



**Step 2**  
Multimeter set to VDC:  
Positive-to-ground reveals  
"0" voltage potential

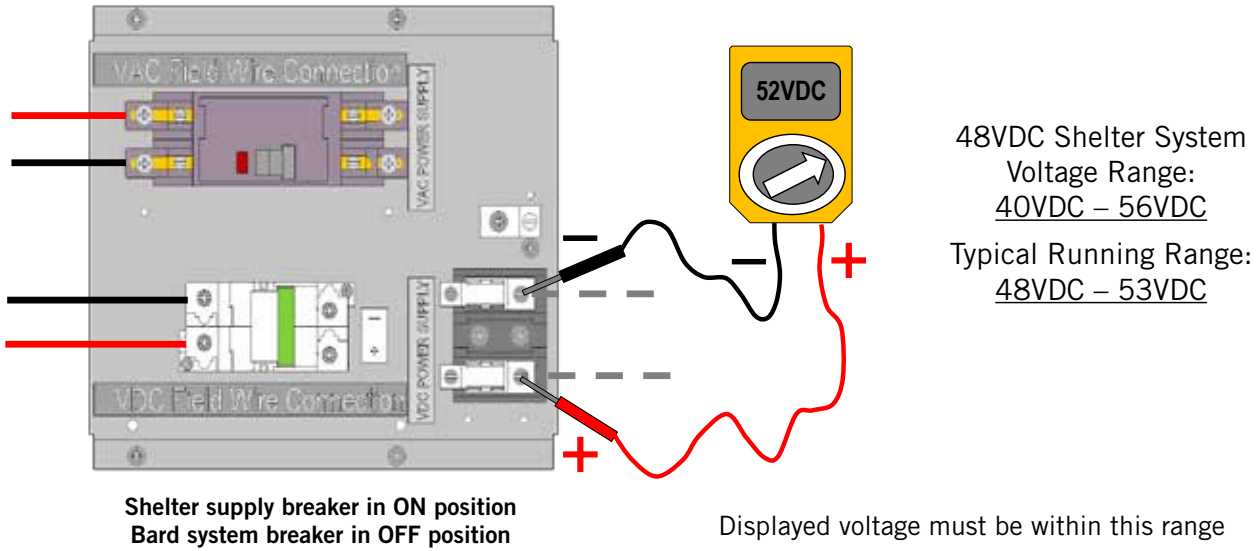


**Step 3**  
Multimeter set to VDC:  
Negative-to-ground reveals  
"-48" voltage potential



**FIGURE 2.19**  
**Verifying Incoming Voltage: VDC**

Multimeter set to VDC



## TROUBLESHOOTING WALL-MOUNT UNIT ALARMS

In the event that a problem is encountered with a wall-mount unit, the TEC-EYE™ hand-held tool may be used to diagnose the cause. If the problem can't be resolved using these guidelines, contact the BARD Technical Service Department at 419.636.0439 for assistance.

| Signal                                     | Description   | Possible Cause   | Component to Check   | Recommended Action   | Device Actions  |
|--|---|--|--|--|---|
| Low Pressure Alarm                         | Alarm is activated when a low pressure event is present in the refrigeration system and the compressor is running.  | Lack of refrigerant  | Run the unit and check if the low pressure value is in the normal range.                                 | Charge appropriate amount of refrigeration.  | Compressor/<br>Condensor Fan:<br>Off  |
|  |   | The switch is defective.   | Check if the pressure switch is OK.  | If defective, replace.   |   |
|  |   | Check if the connection to the corresponding input terminal is ok or if the controller board is defective. | Check if the connection is OK. Check is the controller board is OK.                                      | Reconnect the cables. If the controller board is defective, replace.                 |   |
| High Pressure Alarm                        | If the alarm activates once or twice in an hour, it is reset automatically. If it occurs three times in an hour, the compressor and condenser fan are locked. | Abnormal site condition  | Check open door or for abnormal site condition. Check if the high pressure value is in the normal range. | Clean the condenser.   | Compressor/<br>Condensor Fan:<br>Off  |
|  |   | Condenser fan has failed. The condenser fan speed controller has failed.                                   | Check the condenser fan status while the high pressure is outside the normal setting.                    | Replace the condenser fan. Replace the condenser low ambient (fan speed) controller. |   |
|  |   | The switch is defective.   | Check if the high pressure switch is OK.   | If defective, replace.   |   |
|  |   | Check if the connection to the corresponding input terminal is ok or if the controller board is defective. | Check if the connection is OK. Check is the controller board is OK.                                      | Reconnect the cables. If the controller board is defective, replace.                 |   |
| Landline/Shore/<br>Prime Power<br>Outage   | Alarm is reset automatically.   | Primary power has gone off.  |  |  | Indoor Blower:<br>On<br>Compressor/<br>Condensor Fan:<br>Off<br>Heat: Off<br>Damper: On |
| Dirty Air Filter Alarm                     | The alarm is a warning to check the filter. Alarm can only be reset manually.   | Filter is clogged.   | Check if the filter is dirty.  | Clean or replace the filter.   |   |
|  |   | Check if the connection to the corresponding input terminal is OK or if the controller board is defective. | Check if the connection is OK.   | Reconnect the cable. If the controller board is defective, replace.                  |   |
|  |   | The value set for the differential air pressure switch is too low.   | Check the differential air pressure switch value.  | Correct the value of the switch to standard value.                                   |   |
| DC Free Cooling Damper Fails to Open Alarm | Alarm is reset automatically.   | DC free cooling damper fails to open.  | Check the damper linkage. Check to see if anything is in the way of the damper.                          |  | Indoor Blower:<br>On<br>Damper: Off   |

## TROUBLESHOOTING WALL-MOUNT UNIT ALARMS (CONT.)

| Signal   | Description  | Possible Cause   | Component to Check  | Recommended Action  | Device Actions                   |
|--|--|--|---|---|----------------------------------|
| DC Free Cooling Damper Fails to Close Alarm      | Alarm is reset automatically.  | DC free cooling damper fails to close.   | Check the damper linkage. Check to see if anything is in the way of the damper.   |   | Indoor Blower: On<br>Damper: Off |
| Communication Failed Alarm                       | Alarm is reset automatically.  | Communication is lost with the LC Series main controller.  | Check the RS485 port. Check for damage to the communications cable between the controllers.   | Reconnect the communications cable. If the controller board RS485 port is defective, replace. |                                  |
| Supply Air Temperature Sensor Failed Alarm (B01) | The alarm is activated if the sensor is faulty, a sensor wire is loose or an out-of-range value is read. | The alarm is activated if the sensor is faulty, a sensor wire is loose or an out-of-range value is read. | Check the supply air temperature sensor wiring.<br>Check temperature vs. resistance of temperature sensor (see Table 2.3 on page 31). | Replace the supply air temperature sensor.  |                                  |
| Outdoor Temperature Sensor Failed Alarm (B02)    | The alarm is activated if the sensor is faulty, a sensor wire is loose or an out-of-range value is read. | The alarm is activated if the sensor is faulty, a sensor wire is loose or an out-of-range value is read. | Check the outdoor temperature sensor wiring.<br>Check temperature vs. resistance of temperature sensor (see Table 2.3 on page 31).    | Replace the outdoor temperature sensor.   |                                  |
| Outdoor Humidity Sensor Failed Alarm (B05)       | The alarm is activated if the sensor is faulty, a sensor wire is loose or an out-of-range value is read. | The alarm is activated if the sensor is faulty, a sensor wire is loose or an out-of-range value is read. | Check the humidity sensor wiring.   | Replace the humidity sensor.  |                                  |
| Return Air Temperature Sensor Failed Alarm (B03) | The alarm is activated if the sensor is faulty, a sensor wire is loose or an out-of-range value is read. | The alarm is activated if the sensor is faulty, a sensor wire is loose or an out-of-range value is read. | Check the return air temperature sensor wiring.<br>Check temperature vs. resistance of temperature sensor (see Table 2.3 on page 31). | Replace the return air temperature sensor.  |                                  |

### NEED ASSISTANCE?

This document contains the most current product information as of this printing. For the most up-to-date product information, go to [www.bardhvac.com](http://www.bardhvac.com) where there are links to product specifications, installation instructions, replacement parts manuals and wiring diagrams. Should any assistance be required during the installation or servicing of this product, contact the Bard Technical Service Department at 419.636.0439.

# **SECTION 3:**

# **APPENDIX**

# WALL-MOUNT UNIT ARCHITECTURE

**CAUTION:** The Bard DC Free Cooling Unit System has been pre-programmed with what is widely considered to be the best settings for efficiency and operation. Any changes to internal programming through the LC Series controller or the TEC-EYE™ not covered within this manual may cause the systems to operate improperly, cause internal damage to the HVAC units, cause the shelter to overheat or other very serious consequences. Although complete controller programming architecture for the wall-mount unit controller has been provided, going outside the boundaries of what has been covered in this manual not recommended.

| Screen   | Menu Item             | Range  | Default Value  | Description  |
|--|-----------------------|--|----------------|--|
| <b>MAIN STATUS SCREEN</b>  |                       |  |                |  |
| The Status screen is the default screen on startup, and anytime more than 5 minutes has elapsed from last change. (Use UP/DOWN keys to scroll)         |                       |  |                | Displays current data  |
|  | RAT                   |  | °F             | Current return air temperature   |
|  | SAT                   |  | °F             | Current supply Air temperature   |
|  | OAT                   |  | °F             | Current outdoor air temperature  |
|  | OAH                   |  | %              | Current outdoor air humidity   |
|  | Dewpoint              |  | °F             | Current temperature of dewpoint  |
|  | Blower                | Off/On   |                | Displays status of blower  |
|  | Damper                |  | %              | Displays percentage of current opening   |
|  | Master Control        |  | Master Control | Current operational status, "Running Stand Alone" if communication lost                  |
|  | Status                |  | Unit On        | D-Series controller board is currently active, "Off by Keyboard" if disabled by TEC-EYE™ |
| <b>MAIN MENU</b>   |                       |  |                |  |
| Main Menu screen(s) allows access to operational programming, access by pressing MENU key at any time. (MENU key to enter, use UP/DOWN keys to scroll) |                       |  |                |  |
| <b>ON/OFF UNIT</b>   |                       |  |                |  |
|  | Unit Address          |  | 1              | Physical address of controller   |
|  | Power by Display      | On/Off   | On             |  |
|  | Status                |  | Blower         | "OFF by Keyboard" system has been turned off at controller                               |
| <b>End of ON/OFF UNIT</b>  |                       |  |                |  |
| <b>SETPOINTS</b>   |                       | All setpoint changes are limited to 60 minutes |                |  |
|  | Cooling Setpoint      | 65°F – 90°F                                    | 77°F           |  |
|  | Heating Setpoint      | 52°F – 75°F                                    | 60°F           |  |
|  | Cooling Stg. Diff.    | 1°F – 5°F                                      | 5°F            |  |
|  | Heating Stg. Diff.    | 1°F – 5°F                                      | 2°F            |  |
|  | FreeCool              | 55°F, 57°F, 59°F, 61°F                         | 55°F           |  |
|  | DC OA-Return Diff.    | 0°F – 99.9°F                                   | 7°F            |  |
|  | Supply Temp Low Limit | 28°F – 65°F                                    | 35°F           |  |
|  | Differential          | 0°F – 99.9°F                                   | 20°F           |  |
|  | Damper Time           | 0-999  | 150 seconds    | Time allotted before damper fail is realized   |
|  | Runtest Time          | 0-999  | 60 seconds     |  |
|  | Freeze Temp Low Limit | 0°F – 99.9°F                                   | 30°F           | Temperature sensed by Freezestat which initiates compressor shutdown                     |

| Screen | Menu Item            | Range          | Default Value | Description  |
|--------|----------------------|----------------|---------------|--|
|        | Reset Temperature    | 0°F – 99.9°F   | 55°F          | Temperature sensed by Freezestat which cancels compressor shutdown   |
|        | Reset Time           | 0-999          | 300 seconds   | Time allotted which will also cancel compressor shutdown   |
|        | Blower Settings      |                |               |  |
|        | Continuous           | None/Both/Lead | None          |  |
|        | Blower Speeds        |                |               |  |
|        | Heat                 | 0.0 – 7.6V     | 7.0V          | Control voltage supplied from wall-mount unit control boards to blower in heat                                   |
|        | Econ                 | 0.0 – 7.6V     | 7.0V          | Control voltage supplied from wall-mount unit control boards to blower in regular DC free cooling                |
|        | Econ Low Temp        | 0.0 – 7.6V     | 3.8V          | Control voltage supplied from wall-mount unit control boards to blower in low ambient condition DC free cooling  |
|        | Full Load            | 0.0 – 7.6V     | 6.3V          | Control voltage supplied from wall-mount unit control boards to blower in mechanical cooling                     |
|        | Low Pressure Setup   |                |               |  |
|        | Outside Setpoint     | 0°F – 99.9°F   | 55°F          | Temperature at which control separates two (2) different low pressure situations                                 |
|        | Differential         | 0°F – 9.9°F    | 5°F           | This differential applies to the outside setpoint  |
|        | Above Setpoint Delay | 0-999          | 120 seconds   | Any low pressure situation above the outside setpoint will be delayed 120 seconds before an alarm is initialized |
|        | Below Setpoint Delay | 0-999          | 180 seconds   | Any low pressure situation below the outside setpoint will be delayed 180 seconds before an alarm is initialized |
|        | Time btwn 2 1p       | 0-999          | 15 minutes    |  |
|        | Fieldbus Address     | 0-999          | 11            |  |
|        | Compressor Timers    |                |               |  |
|        | Minimum Off          | 0-999          | 120 seconds   | Once stopped, the compressor remains inactive for this period of time  |
|        | Minimum On           | 0-999          | 300 seconds   | Once started, the compressor remains on for this period of time  |
|        | Comp Stage Delay     | 0-999          | 60 seconds    | Minimum run time for first stage of two-stage compressors  |
|        | Modulating Setup     |                |               |  |
|        | Damper               |                |               |  |
|        |                      | DIR/REV Both   |               |  |
|        | Cntrl: DIR P+1       | P/P+I/PID      |               |  |
|        | Band                 | 0-999          | 75            |  |
|        | Deadband             | 99.9           | 0             |  |
|        | Int.                 | 0-999          | 120 seconds   |  |
|        | Minimum              | 0-999          | 0             |  |

## WALL-MOUNT UNIT ARCHITECTURE (CONT.)

| Screen                        | Menu Item                        | Range                              | Default Value             | Description   |
|-------------------------------|----------------------------------|------------------------------------|---------------------------|---|
|                               | Maximum                          | -1000 – 1000                       | 1000                      |   |
|                               | Period                           | 500 – 9999mS                       | 500mS                     |   |
| <b>End of SETPOINTS</b>       |                                  |                                    |                           |   |
| <b>CLOCK/SCHEDULER</b>        |                                  |                                    |                           |   |
|                               | Clock                            |                                    |                           |   |
|                               | Time                             |                                    |                           |   |
|                               | Date                             |                                    | (Current date)            |   |
|                               | Hour                             | 1:00 – 24:00                       | (Current time)            |   |
|                               | Day                              | Mon. – Fri.                        | (Current day of week)     |   |
|                               | Daylight Savings Time            | Enable/Disable                     | Enable                    | System clock will follow DST Protocol, "Disable" if desired |
|                               | Transition Time                  | 0-240                              | 60 minutes                |   |
|                               | Start:                           | First, Second, Third, Fourth, Last | Last                      |   |
|                               |                                  | Sunday – Saturday                  | Sunday                    |   |
|                               |                                  | January – December                 | March                     |   |
|                               |                                  | 0:00 – 12:00                       | 2:00                      |   |
|                               | End: F in at 0.00 - 12.00        | irst, Second, Third, Fourth, Last  | Last                      |   |
|                               |                                  | Sunday – Saturday                  | Sunday                    |   |
|                               |                                  | January – December                 | October                   |   |
|                               |                                  | 0:00 – 12:00                       | 3:00                      |   |
| <b>End of CLOCK/SCHEDULER</b> |                                  |                                    |                           |   |
| <b>INPUTS/OUTPUTS</b>         |                                  |                                    |                           |   |
|                               | Analog Inputs                    |                                    |                           |   |
|                               | Supply Air Temp Input B001       |                                    | (Current SAT)             |   |
|                               | Outdoor Air Temp Input B002      |                                    | (current OAT)             |   |
|                               | Return Air Temp Input B003       |                                    | (Current RAT)             |   |
|                               | Outdoor Humidity Input B005      |                                    | (Current %RH)             |   |
|                               | Freezestat Input B007            |                                    | (Current Freezestat temp) |   |
|                               | Digital Inputs                   |                                    |                           |   |
|                               | Power Loss DI 1 Status           |                                    | Open                      |   |
|                               | Filter Switch DI 2 Status        |                                    | Open                      |   |
|                               | High Pressure Switch DI 3 Status |                                    | Open                      |   |



| Screen                       | Menu Item                         | Range                 | Default Value   | Description                    |
|------------------------------|-----------------------------------|-----------------------|-----------------|--------------------------------|
|                              | Low Pressure Switch<br>DI4 Status |                       | Open            |                                |
|                              | Blower DI 5 Status                |                       | Open            |                                |
|                              | Damper Switch<br>DI 6 Status      |                       | Open            |                                |
|                              | Relay Outputs                     |                       |                 |                                |
|                              | Cooling Stage 1<br>Relay 2 Status |                       | Off             |                                |
|                              | Cooling Stage 2<br>Relay 3 Status |                       | Off             |                                |
|                              | Heating Relay 4 Status            |                       | Off             |                                |
|                              | Blower Relay 7 Status             |                       | Off             |                                |
|                              | Analog Outputs                    |                       |                 |                                |
|                              | Analog Output 1<br>Blower Motor   |                       | 0.00vdc         |                                |
|                              | Analog Output 2 Damper            |                       | 2.70vdc         |                                |
| <b>End of INPUTS/OUTPUTS</b> |                                   |                       |                 |                                |
|                              | <b>ALARM HISTORY</b>              |                       |                 |                                |
|                              | 020: Damper Close Fail            |                       |                 |                                |
|                              | Supply Air                        |                       |                 |                                |
|                              | Outdoor Air                       |                       |                 |                                |
|                              | Return Air                        |                       |                 |                                |
|                              | Outdoor Humidity                  |                       |                 |                                |
|                              | Blower Speed                      |                       |                 |                                |
|                              | Damper Position                   |                       |                 |                                |
| <b>End of ALARM HISTORY</b>  |                                   |                       |                 |                                |
|                              | <b>TECHNICIAN</b>                 |                       |                 |                                |
|                              | Information                       |                       |                 |                                |
|                              | Bard Code                         | -3276.8 –<br>3276.7   | Unit Controller |                                |
|                              | Version                           | 0-99                  | 1.20            |                                |
|                              | Bios                              | 0-99                  | 6.33            |                                |
|                              | Boot                              | 0-99                  | 4.05            |                                |
|                              | FLSH 2048                         | 9999                  |                 | Internal memory specifications |
|                              | RAM 512                           | 999                   |                 |                                |
|                              | OMB                               | 0-9                   |                 |                                |
|                              | T memory writes                   | 0-32767               |                 |                                |
|                              | 4.8 cycle/s                       | 0-9999                |                 |                                |
|                              | Power Cycle Status                |                       |                 |                                |
|                              | Last On Time                      | 0-99                  |                 |                                |
|                              | Last Off Time                     | 0-99                  |                 |                                |
|                              | Length Time Off                   | 0-32767               |                 |                                |
|                              | Days: ### Hrs: ###<br>Min: ###    | 32767/32767/<br>32767 |                 |                                |

## **WALL-MOUNT UNIT ARCHITECTURE (CONT.)**

| Screen | Menu Item               | Range            | Default Value | Description        |
|--------|-------------------------|------------------|---------------|--------------------|
|        | Working Hours           |                  |               |                    |
|        | Run Hours               | -3276.8 – 3276.7 |               |                    |
|        | Compressor              |                  |               |                    |
|        | Run Hours               | -3276.8 – 3276.7 |               | Hours of operation |
|        | Num Starts              | -3276.8 – 3276.7 |               | Number of starts   |
|        | Compressor Full Load    |                  |               |                    |
|        | Run Hours               | -3276.8 – 3276.7 |               | Hours of operation |
|        | Num Starts              | -3276.8 – 3276.7 |               | Number of starts   |
|        | Free Cool               |                  |               |                    |
|        | Run Hours               | -3276.8 – 3276.7 |               | Hours of operation |
|        | Num Starts              | -3276.8 – 3276.7 |               | Number of starts   |
|        | Heat                    |                  |               |                    |
|        | Run Hours               | -3276.8 – 3276.7 |               | Hours of operation |
|        | Num Starts              | -3276.8 – 3276.7 |               | Number of starts   |
|        | Blower                  |                  |               |                    |
|        | Run Hours               | -3276.8 – 3276.7 |               | Hours of operation |
|        | Num Starts              | -3276.8 – 3276.7 |               | Number of starts   |
|        | Service Settings        |                  |               |                    |
|        | Control Loops           |                  |               |                    |
|        | Modulating Setup Damper |                  |               |                    |
|        | Input                   | 0-999            |               |                    |
|        | Output                  | 0-9              | 0             |                    |
|        | Setpoint                | 0-99.9           | 55            |                    |
|        | Band                    | 1.0 – 999.9      | 75            |                    |
|        | Integration Time        | 1-999            | 120           |                    |
|        | Delays                  |                  |               |                    |
|        | Damper Alarm Delays     |                  |               |                    |
|        | Fail to Open            | 0 – 999s         | 20s           |                    |
|        | Fail to Close           | 0 – 999s         | 300s          |                    |
|        | Freezer Start           | 0 – 999s         | 120s          |                    |
|        | Freecoll Cp             | 0 – 999s         | 90s           |                    |
|        | Run Test                |                  |               |                    |
|        | Run Test Time           | 0 – 999s         | 60s           |                    |
|        | Enable                  | Yes/No           | No            |                    |

| Screen | Menu Item                       | Range            | Default Value  | Description   |
|--------|---------------------------------|------------------|----------------|---|
|        | Language                        |                  |                |   |
|        | Language                        | 0-1              | English        |   |
|        | Probe Adjustment                |                  |                |   |
|        | Analog Inputs                   |                  |                |   |
|        | SAT Input B001                  |                  |                |   |
|        | Offset                          | -9.9 – 9.9       | 0              |   |
|        | Value                           | -3276.8 – 3276.7 |                |   |
|        | OAT Input B002                  |                  |                |   |
|        | Offset                          | -9.9 – 9.9       | 0              |   |
|        | Value                           | -3276.8 – 3276.7 |                |   |
|        | RAT Input B003                  |                  |                |   |
|        | Offset                          | -9.9 – 9.9       | 0              |   |
|        | Value                           | -3276.8 – 3276.7 |                |   |
|        | Outdoor Air Humidity Input B005 |                  |                |   |
|        | Offset                          | -9.9 – 9.9       | 0              |   |
|        | Value                           | -3276.8 – 3276.7 |                |   |
|        | Freezestat Input B007           |                  |                |   |
|        | Offset                          | -9.9 – 9.9       | 0              |   |
|        | Value                           | -3276.8 – 3276.7 |                |   |
|        | Manual Management               |                  |                |   |
|        | Analog Inputs                   |                  |                |   |
|        | Supply Air Temp                 |                  |                |   |
|        | Manual Control B001             | Off/On           | Off            | On to manually change temperature seen by controller  |
|        | Manual Position                 | -1000 – 1000     | 0              | Degrees of change in sensor for manual control        |
|        | Value                           |                  | (Temp + Value) | Current temperature plus the value in manual position |
|        | Outdoor Air Temp                |                  |                |   |
|        | Manual Control B002             | Off/On           | Off            | On to manually change temperature seen by controller  |
|        | Manual Position                 | -1000 – 1000     | 0              | Degrees of change in sensor for manual control        |
|        | Value                           |                  | (Temp + Value) | Current temperature plus the value in manual position |

## **WALL-MOUNT UNIT ARCHITECTURE (CONT.)**

| Screen | Menu Item            | Range        | Default Value  | Description   |
|--------|----------------------|--------------|----------------|---|
|        | Return Air Temp      |              |                |   |
|        | Manual Control B003  | Off/On       | Off            | On to manually change temperature seen by controller                |
|        | Manual Position      | -1000 – 1000 | 0              | Degrees of change in sensor for manual control                      |
|        | Value                |              | (Temp + Value) | Current temperature plus the value in manual position               |
|        | Outdoor Humidity     |              |                |   |
|        | Manual Control B005  | Off/On       | Off            | On to manually change temperature seen by controller                |
|        | Manual Position      | -1000 – 1000 | 0              | Degrees of change in sensor for manual control                      |
|        | Value                |              | (% RH + Value) | Current %RH plus the value in manual position                       |
|        | Freeze               |              |                |   |
|        | Manual Control B007  | Off/On       | Off            | On to manually change temperature seen by controller                |
|        | Manual Position      | -1000 – 1000 | 0              | Degrees of change in sensor for manual control                      |
|        | Value                |              | (Temp + Value) | Current temperature plus the value in manual position               |
|        | Digital Inputs       |              |                |   |
|        | Power Loss           |              |                |   |
|        | Manual DI 1          | Off/On       | Off            | "On" to allow artificial manipulation power loss input              |
|        | Manual Position      | Closed/Open  | Closed         | Change to "Open" to artificially create power loss input            |
|        | D1 Status            |              |                | Current status of power loss input (closed means no input)          |
|        | Filter Switch        |              |                |   |
|        | Manual DI 2          | Off/On       | Off            | "On" to allow artificial manipulation filter switch input           |
|        | Manual Position      | Closed/Open  | Closed         | Change to "Open" to artificially create filter switch input         |
|        | D2 Status            |              |                | Current status of filter switch input (closed means no input)       |
|        | High Pressure Switch |              |                |   |
|        | Manual DI 3          | Off/On       | Off            | "On" to allow artificial manipulation of high pressure switch input |
|        | Manual Position      | Closed/Open  | Closed         | Change to "Closed" to artificially create high pressure input       |
|        | D3 Status            |              |                | Current status of high pressure input (open means no input)         |
|        | Low Pressure Switch  |              |                |   |
|        | Manual DI 4          | Off/On       | Off            | "On" to allow artificial manipulation of low pressure switch input  |
|        | Manual Position      | Closed/Open  | Closed         | Change to "Closed" to artificially create low pressure input        |

| Screen | Menu Item          | Range       | Default Value | Description   |
|--------|--------------------|-------------|---------------|---|
|        | D4 Status          |             |               | Current status of low pressure input (open means no input)            |
|        | Blower Status      |             |               |   |
|        | Manual DI 5        | Off/On      | Off           | "On" to allow artificial manipulation of blower status input          |
|        | Manual Position    | Closed/Open | Closed        | Change to "Closed" to artificially create blower status input         |
|        | D5 Status          |             |               | Current status of blower status input (open means no input)           |
|        | Damper Switch      |             |               |   |
|        | Manual Status DI 6 | Off/On      | Off           | "On" to allow artificial manipulation of damper switch status input   |
|        | Manual Position    | Closed/Open | Closed        | Change to "Closed" to artificially create damper switch status input  |
|        | D3 Status          |             |               | Current status of damper switch status input (open means no input)    |
|        | Relay Outputs      |             |               |   |
|        | Cooling Stg 1      |             |               |   |
|        | Manual Relay 2     | Off/On      | Off           | "On" to allow artificial manipulation of cooling stage 1 relay action |
|        | Manual Position    | Off/On      | Off           | Change to "On" to artificially force cooling stage 1 relay            |
|        | Relay 2 Status     | Off/On      | Off           | Current status of cooling stage 1 relay (off means no relay action)   |
|        | Cooling Stg 2      |             |               |   |
|        | Manual Relay 3     | Off/On      | Off           | "On" to allow artificial manipulation of cooling stage 2 relay action |
|        | Manual Position    | Off/On      | Off           | Change to "On" to artificially force cooling stage 2 relay            |
|        | Relay 3 Status     | Off/On      | Off           | Current status of cooling stage 2 relay (off means no relay action)   |
|        | Heating            |             |               |   |
|        | Manual Relay 6     | Off/On      | Off           | "On" to allow artificial manipulation of heating relay action         |
|        | Manual Position    | Off/On      | Off           | Change to "On" to artificially force heating relay                    |
|        | Relay 6 Status     | Off/On      | Off           | Current status of heating relay (off means no relay action)           |
|        | HVAC 2 Fail Alarm  |             |               |   |
|        | Manual Relay 4     | Off/On      | Off           |   |
|        | Manual Position    | Off/On      | Off           |   |
|        | Relay 4 Status     | Off/On      | Off           |   |
|        | Blower             |             |               |   |
|        | Manual Relay 7     | Off/On      | Off           | "On" to allow artificial manipulation of blower relay action          |
|        | Manual Position    | Off/On      | Off           | Change to "On" to artificially force blower relay                     |

## **WALL-MOUNT UNIT ARCHITECTURE (CONT.)**

| Screen                   | Menu Item             | Range         | Default Value | Description  |
|--------------------------|-----------------------|---------------|---------------|--|
|                          | Relay 7 Status        | Off/On        | Off           | Current status of blower relay (off means no relay action) |
|                          | Analog Outputs        |               |               |  |
|                          | Analog Output 1       |               |               |  |
|                          | Blower Motor          |               |               |  |
|                          | Mode                  | Hand/Auto     | Auto          |  |
|                          | Manual Value          | 0.0 – 10.0vdc | 0vdc          |  |
|                          | Output                | 0.0 – 10.0vdc |               |  |
|                          | Analog Output 2       |               |               |  |
|                          | Damper                |               |               |  |
|                          | Mode                  | Hand/Auto     | Auto          |  |
|                          | Manual Value          | 0.0 – 10.0vdc | 0vdc          |  |
|                          | Output                | 0.0 – 10.0vdc |               |  |
| <b>End of TECHNICIAN</b> |                       |               |               |  |
|                          | <b>FACTORY</b>        |               |               |  |
|                          | Initialization        |               |               |  |
|                          | Passwords             |               |               |  |
|                          | Insert new passwords  |               |               |  |
|                          | User                  |               | 2000          |  |
|                          | Technician (PW1)      |               | 1313          |  |
|                          | Factory (PW2)         |               | 9254          |  |
|                          | Configuration         |               |               |  |
|                          | Temperature Units     | °F/°C         | °F            |  |
|                          | Pressure Units        | psi/bar       | psi           |  |
|                          | Force Clock Enable    | Yes/No        | Yes           |  |
|                          | Clock Mode            | 24h/12h       | 24 hour       |  |
|                          | Disable Buzzer        | Yes/No        | Yes           |  |
|                          | Startup Delay         | 0s – 9999s    | 1 second      |  |
|                          | Enable Unit           |               |               |  |
|                          | by digit input        | On/Off        | On            |  |
|                          | by supervisor         | On/Off        | Off           |  |
|                          | by pLAN network       | On/Off        | On            |  |
|                          | by schedule           | On/Off        | Off           |  |
|                          | Analog Input Fitering |               |               |  |
|                          | Enable                | No/Yes        | No            |  |
|                          | Input 1               | 4s – 256ms    | 19 seconds    |  |
|                          | Input 2               | 4s – 256ms    | 19 seconds    |  |
|                          | Input 3               | 4s – 256ms    | 19 seconds    |  |
|                          | Input 4               | 4s – 256ms    | 19 seconds    |  |
|                          | Input 5               | 4s – 256ms    | 19 seconds    |  |
|                          | Factory Settings      |               |               |  |
|                          | Manual Control Reset  |               |               |  |
|                          | Enable                | Yes/No        | Yes           |  |

| Screen | Menu Item            | Range  | Default Value | Description |
|--------|----------------------|--|---------------|-------------|
|        | Time                 | 0m – 500m  | 60m           |             |
|        | Local Setpoint Reset | 0m – 180m  | 60m           |             |
|        | PW/Return Delay      | 0s – 9999s   | 300s          |             |
|        | I/O Configuration    |  |               |             |
|        | Analog Inputs        |  |               |             |
|        | Supply Air Temp      |  |               |             |
|        | Enable B001          | On/Off   | On            |             |
|        | Resolution           | Normal/High Res.   |               |             |
|        | Type                 | <b>Ohm x5</b> , Ohm x1,<br>NTC, PT1000,<br>0-1VDC,<br>0-10VDC,<br>4-20mA, On/Off,<br>0-4VDC, NTC HT,<br>50T90, 10T170,<br>nu10,<br>SPKP00B7T0,<br>nu12, nu13 | Normal Ohm x5 |             |
|        | Minimum              | -3276.8 –<br>3276.7  | 0.0           |             |
|        | Maximum              | -3276.8 –<br>3276.7  | 100.0         |             |
|        | Offset               | -3276.8 –<br>3276.7  | 0.0           |             |
|        | Value                | -3276.8 –<br>3276.7  |               |             |
|        | Supply Air Temp      |  |               |             |
|        | Input B001           | ###  |               |             |
|        | Out of Range Alarm   |  |               |             |
|        | Power Delay          | 0s – 999s  | 5 Seconds     |             |
|        | Run Delay            | 0s – 999s  | 5 Seconds     |             |
|        | Units                | Pressure/<br>Temperature/<br>Other   |               |             |
|        | Outdoor Air Temp     |  |               |             |
|        | Enable B002          | On/Off   | On            |             |
|        | Resolution           | Normal/High Res.   |               |             |
|        | Type                 | <b>Ohm x5</b> , Ohm x1,<br>NTC, PT1000,<br>0-1VDC,<br>0-10VDC,<br>4-20mA, On/Off,<br>0-4VDC, NTC HT,<br>50T90, 10T170,<br>nu10,<br>SPKP00B7T0,<br>nu12, nu13 | Normal Ohm x5 |             |
|        | Minimum              | -3276.8 –<br>3276.7  | 0.0           |             |

## WALL-MOUNT UNIT ARCHITECTURE (CONT.)

| Screen | Menu Item          | Range  | Default Value | Description |
|--------|--------------------|--|---------------|-------------|
|        | Maximum            | -3276.8 – 3276.7   | 100.0         |             |
|        | Offset             | -3276.8 – 3276.7   | 0.0           |             |
|        | Value              | -3276.8 – 3276.7   |               |             |
|        | Outdoor Air Temp   |  |               |             |
|        | Input B002         |  |               |             |
|        | Out of Range Alarm |  |               |             |
|        | Power Delay        | 0s – 999s  | 5 Seconds     |             |
|        | Run Delay          | 0s – 999s  | 5 Seconds     |             |
|        | Units              | Pressure/<br>Temperature/<br>Other   | Temperature   |             |
|        | Return Air Temp    |  |               |             |
|        | Enable B003        | On/Off   | On            |             |
|        | Resolution         | Normal/High Res.   |               |             |
|        | Type               | <b>Ohm x5</b> , Ohm x1,<br>NTC, PT1000,<br>0-1VDC,<br>0-10VDC,<br>4-20mA, On/Off,<br>0-4VDC, NTC HT,<br>50T90, 10T170,<br>nu10,<br>SPKP00B7T0,<br>nu12, nu13 | Normal Ohm x5 |             |
|        | Minimum            | -3276.8 – 3276.7   | 0.0           |             |
|        | Maximum            | -3276.8 – 3276.7   | 100.0         |             |
|        | Offset             | -3276.8 – 3276.7   | 0.0           |             |
|        | Value              | -3276.8 – 3276.7   |               |             |
|        | Return Air Temp    |  |               |             |
|        | Input B003         |  |               |             |
|        | Out of Range Alarm |  |               |             |
|        | Power Delay        | 0s – 999s  | 5 Seconds     |             |
|        | Run Delay          | 0s – 999s  | 5 Seconds     |             |
|        | Units              | Pressure/<br>Temperature/<br>Other   | Temperature   |             |
|        | Outdoor Humidity   |  |               |             |
|        | Enable B005        | On/Off   | On            |             |
|        | Resolution         | Normal/High Res.   |               |             |



| Screen | Menu Item          | Range  | Default Value | Description |
|--------|--------------------|--|---------------|-------------|
|        | Type               | Ohm x5, Ohm x1,<br>NTC, PT1000,<br>0-1VDC,<br>0-10VDC,<br><b>4-20mA</b> , On/Off,<br>0-4VDC, NTC HT,<br>50T90, 10T170,<br>nu10,<br>SPKP00B7T0,<br>nu12, nu13 | Normal 4-20mA |             |
|        | Minimum            | -3276.8 –<br>3276.7  | 0.0           |             |
|        | Maximum            | -3276.8 –<br>3276.7  | 100.0         |             |
|        | Offset             | -3276.8 –<br>3276.7  | 0.0           |             |
|        | Value              | -3276.8 –<br>3276.7  |               |             |
|        | Outdoor Humidity   |  |               |             |
|        | Input B005         |  |               |             |
|        | Out of Range Alarm |  |               |             |
|        | Power Delay        | 0s – 999s  | 5 Seconds     |             |
|        | Run Delay          | 0s – 999s  | 5 Seconds     |             |
|        | Units              | Pressure/<br>Temperature/<br>Other   |               |             |
|        | Freeze             |  |               |             |
|        | Enable B007        | On/Off   | On            |             |
|        | Resolution         | Normal/High Res.   |               |             |
|        | Type               | Ohm x5, Ohm x1,<br>NTC, PT1000,<br>0-1VDC,<br>0-10VDC,<br><b>4-20mA</b> , On/Off,<br>0-4VDC, NTC HT,<br>50T90, 10T170,<br>nu10,<br>SPKP00B7T0,<br>nu12, nu13 | Normal 4-20mA |             |
|        | Minimum            | -3276.8 –<br>3276.7  | 0.0           |             |
|        | Maximum            | -3276.8 –<br>3276.7  | 100.0         |             |
|        | Offset             | -3276.8 –<br>3276.7  | 0.0           |             |
|        | Value              | -3276.8 –<br>3276.7  |               |             |
|        | Outdoor Humidity   |  |               |             |
|        | Input B007         |  |               |             |
|        | Out of Range Alarm |  |               |             |

## WALL-MOUNT UNIT ARCHITECTURE (CONT.)

| Screen | Menu Item            | Range                              | Default Value | Description |
|--------|----------------------|------------------------------------|---------------|-------------|
|        | Power Delay          | 0s – 999s                          | 5 Seconds     |             |
|        | Run Delay            | 0s – 535s                          | 5 Seconds     |             |
|        | Units                | Pressure/<br>Temperature/<br>Other | Pressure      |             |
|        | Digital Inputs       |                                    |               |             |
|        | Power Loss Switch    |                                    |               |             |
|        | Enable Channel 1     | On/Off                             | On            |             |
|        | Action               | Closed/Open                        | Closed        |             |
|        | Delay                | 0s – 999s                          | 0 Seconds     |             |
|        | Status               |                                    |               |             |
|        | Filter Switch        |                                    |               |             |
|        | Enable Channel 2     | On/Off                             | On            |             |
|        | Action               | Closed/Open                        | Closed        |             |
|        | Delay                | 0s – 999s                          | 1 Second      |             |
|        | Status               |                                    |               |             |
|        | High Pressure Switch |                                    |               |             |
|        | Enable Channel 3     | On/Off                             | On            |             |
|        | Action               | Closed/Open                        | Open          |             |
|        | Delay                | 0s – 999s                          | 0 Seconds     |             |
|        | Status               |                                    |               |             |
|        | Low Pressure Switch  |                                    |               |             |
|        | Enable Channel 4     | On/Off                             | On            |             |
|        | Action               | Closed/Open                        | Open          |             |
|        | Delay                | 0s – 999s                          | 0 Seconds     |             |
|        | Status               |                                    |               |             |
|        | Blower Status        |                                    |               |             |
|        | Enable Channel 5     | On/Off                             | On            |             |
|        | Action               | Closed/Open                        | Closed        |             |
|        | Delay                | 0s – 999s                          | 0 Seconds     |             |
|        | Status               |                                    |               |             |
|        | Damper Switch        |                                    |               |             |
|        | Enable Channel 6     | On/Off                             | On            |             |
|        | Action               | Closed/Open                        | Closed        |             |
|        | Delay                | 0s – 999s                          | 0 Seconds     |             |
|        | Status               |                                    |               |             |
|        | Relay Outputs        |                                    |               |             |
|        | Cooling Stage 1      |                                    |               |             |
|        | Enable               | No/Yes                             | Yes           |             |
|        | Channel              | 2                                  |               |             |
|        | Direction            | N.O./N.C.                          | N.O.          |             |
|        | Status               |                                    | Off           |             |

| Screen                | Menu Item            | Range          | Default Value | Description                   |
|-----------------------|----------------------|----------------|---------------|-------------------------------|
|                       | Cooling Stage 2      |                |               |                               |
|                       | Enable               | No/Yes         | Yes           |                               |
|                       | Channel              | 3              |               |                               |
|                       | Direction            | N.O./N.C.      | N.O.          |                               |
|                       | Status               |                | Off           |                               |
|                       | Heating              |                |               |                               |
|                       | Enable               | No/Yes         | Yes           |                               |
|                       | Channel              | 4              |               |                               |
|                       | Direction            | N.O./N.C.      | N.O.          |                               |
|                       | Status               |                | Off           |                               |
|                       | Blower               |                |               |                               |
|                       | Enable               | No/Yes         | Yes           |                               |
|                       | Channel              | 7              |               |                               |
|                       | Direction            | N.O./N.C.      | N.O.          |                               |
|                       | Status               |                | Off           |                               |
|                       | Analog Outputs       |                |               |                               |
|                       | Blower Motor         |                |               |                               |
|                       | Enable               | Yes/No         | Yes           |                               |
|                       | Channel              | 1/0            | 1             |                               |
|                       | Action               | Direct/Reverse | Direct        |                               |
|                       | Minimum              | 0 – 10v        | 0v            |                               |
|                       | Maximum              | 0 – 10v        | 10v           |                               |
|                       | Damper               |                |               |                               |
|                       | Enable               | Yes/No         | Yes           |                               |
|                       | Channel              | 2/0            | 2             |                               |
|                       | Action               | Direct/Reverse | Direct        |                               |
|                       | Minimum              | 0 – 10v        | 2.7v          |                               |
|                       | Maximum              | 0 – 10v        | 10v           |                               |
|                       | Factory Settings     |                |               |                               |
|                       | Damper Delay Test    |                |               |                               |
|                       | Enable               | Yes/No         | Yes           |                               |
|                       | Voltage              | 0 – 10v        | 2.5v          |                               |
|                       | Time                 | 0s – 999s      | 30 seconds    |                               |
|                       | Blower Status Switch |                |               |                               |
|                       | Minimum Off          | 0s – 999s      | 45 seconds    |                               |
|                       | Unit Controller      |                |               |                               |
|                       | Serial Number        | 00000000000000 |               | Wall-mount unit serial number |
|                       | Model Number         | 60 X           |               | Wall-mount unit model number  |
| <b>End of FACTORY</b> |                      |                |               |                               |