INSTALLATION AND SERVICE INSTRUCTIONS

DC FREE COOLING UNIT SYSTEM

TWO (2) D-SERIES DUAL-TEC™
WALL-MOUNTED PACKAGE
AIR CONDITIONERS

&

ONE (1) BARD-LINK™ PLC
LEAD/LAG CONTROLLER

AIR CONDITIONER MODELS

D28A2PA	D48A2PA	D28L2PA	D48L2PA
D28A2PB	D48A2PB	D28L2PB	D48L2PB
D36A2PA	D60A2PA	D36L2PA	D60L2PA
D36A2PB	D60A2PB	D36L2PB	D60L2PB
D42A2PA		D42L2PA	
D42A2PB		D42L2PB	

CONTROLLER MODEL

LC2000-100

**NOTE: BARD-LINK™ LC2000-100 Controllers must be used with
D-Series Wall-Mount Units**



Climate Control Solutions

Bard Manufacturing Company, Inc.
Bryan, Ohio 43506
www.bardhvac.com

Manual : 2100-643
Supersedes: **NEW**
Date: 10-27-15

CONTENTS

SECTION 1: Installation Instructions	7
List of Necessary Materials/Tools	8
Site Preparation	9
Wall-Mount Unit Installation	11
Wall-Mount Unit Supply Wiring.....	15
Preliminary Start-Up.....	19
Bard-Link™ Controller Installation	20
System Start-Up	34
SECTION 2: Service Instructions	37
General Refrigerant Information.....	38
Sequence of Operation	40
Advanced Programming	47
Using the TEC-EYE	52
Componentry Specifications	55
Maintenance and Troubleshooting.....	62
SECTION 3: Appendices	71
Appendix 1: LC-Series Controller Architecture.....	72
Appendix 2: TEC-EYE Architecture	79

FIGURES AND TABLES

Figure 1.1 Wall-Mount Unit Model Nomenclature	8
Figure 1.2 Dimensions.....	10
Figure 1.3 Mounting Instructions	12
Figure 1.4 Electric Heat Clearance.....	13
Figure 1.5 Wall Mounting Instructions.....	13
Figure 1.6 Wall Mounting Instructions.....	14
Figure 1.7 Common Wall Mounting Installations.....	14
Figure 1.8 Circuit Routing Label	16
Figure 1.9 WIRING: VAC Supply Wiring Landing Points. 16	
Figure 1.10 Adjusting the 230/208VAC Transformer.. 17	
Figure 1.11 WIRING: VDC Supply Wiring Landing Points. 17	
Figure 1.12 Bard Polarity-Voltage Monitor.....	18
Figure 1.13 WIRING: Typical LC2000 Wiring.....	20
Figure 1.14 Remote Temperature Sensor Install	22
Figure 1.15 Additional Remote Temp Sensor Install... 23	
Figure 1.16 Power and Signal Connections – Smoke.. 24	
Figure 1.17 Power/Signal Connections – Hydrogen 25	
Figure 1.18 LC2000 Generator Run	25
Figure 1.19 WIRING: LC2000 External Alarm Wiring.. 26	
Figure 1.20 WIRING: Communication Wiring	27
Figure 1.21 WIRING: Communication Wiring: Controller Termination.....	28
Figure 1.22 WIRING: Communication Wiring: 1st Unit Termination	29
Figure 1.23 WIRING: Communication Wiring: 2nd Unit Termination.....	30
Figure 1.24 Controller Supply Wiring.....	31
Figure 1.25 Controller Grounding Posts	31
Figure 1.26 WIRING: LC2000 Wiring Diagram	33
Figure 1.27 Bard-Link™ Controller Display	34
Figure 1.28 Clock/Scheduler Menu	34
Figure 1.29 Status Display Showing Units "Online".... 34	
Figure 1.30 Executing Run Test.....	35
Figure 2.1 Refrigerant Sight Glass	39
Figure 2.2 Wall-Mount Unit Control Board	41
Figure 2.3 Controller Board and Terminal Block.....	43
Figure 2.4 LC Series Controller Control Board	44
Figure 2.5 Free Cooling Damper Operation.....	46
Figure 2.6 Bard-Link™ Controller Display	47
Figure 2.7 Controller Status Display	48
Figure 2.8 TEC-EYE Display	52
Figure 2.9 TEC-EYE Connection to Unit Control	52
Figure 2.10 TEC-EYE Status Display	53
Figure 2.11 Fan Blade Setting.....	57
Figure 2.12 Dirty Filter Switch.....	57
Figure 2.13 Power Loss Relay Circuit	58
Figure 2.14 High Pressure Relay Circuit	58
Figure 2.15 Blower Motor Start Relay Circuit	58
Figure 2.16 Unit Control Panel	59
Figure 2.17 WIRING: Unit Wiring Diagram.....	60
Figure 2.18 Low Voltage Connections	61
Figure 2.19 Troubleshooting Motor Power Supply	63
Figure 2.20 Troubleshooting Motor Start Command ... 64	
Figure 2.21 Troubleshooting Speed Voltage.....	64
Figure 2.22 VDC Polarity Check.....	65
Figure 2.23 Verifying Incoming Voltage.....	66
Table 1.1 Electrical Specifications	15
Table 1.2 Terminal Block Index.....	32
Table 1.3 Controller Default Settings	36
Table 2.1 Nominal Pressures	39
Table 2.2 Blower Speed Voltage Chart	40
Table 2.3 Controller Default Settings	46
Table 2.4 Controller Programmable Features	50
Table 2.5 Temp vs. Resistance of Temp Sensor.....	56
Table 2.6 Indoor Blower Performance	57
Table 2.7 Troubleshooting 48VDC Blower Motor.....	63
Table 2.8 Blower Speed Voltage Chart	64

GENERAL INFORMATION

DC FREE COOLING UNIT SYSTEM (DC-FCU)

The Bard DC Free Cooling Unit system is composed of two (2) D-Series DUAL-TEC™ wall-mounted air conditioners matched with one (1) Bard-Link™ PLC lead/lag controller. The D-Series, specifically engineered for the telecom market, can provide outdoor air cooling during power loss situations through the use of onsite -48VDC positive ground battery banks.

NOTE: *The Bard-Link™ PLC lead/lag controller and the D-Series wall-mount units are designed specifically to work together. The PLC controller cannot run other Bard models or other brands of systems, nor can other controllers or thermostats run the D-Series wall-mount units. They are a complete system, and must be used together.*

WALL-MOUNT AIR CONDITIONER UNITS

The D-Series units operate on both VAC and VDC power under normal power supply conditions. If there is loss of VAC power supply (shore and/or back-up generator) the unit will continue to operate as free cooling or ventilation system using the shelter's VDC power. The indoor blower and free cooling unit operate from -48VDC and no inverter is required.

The units will supply 100% of rated cooling airflow in free cooling mode with ability to exhaust the same amount through the unit itself without any additional relief openings in the shelter.

Each of these units are fully charged with refrigerant and have auxilliary heat installed.

BARD-LINK™ PLC CONTROLLER

LC2000-100 (controller and accessories included shown below).

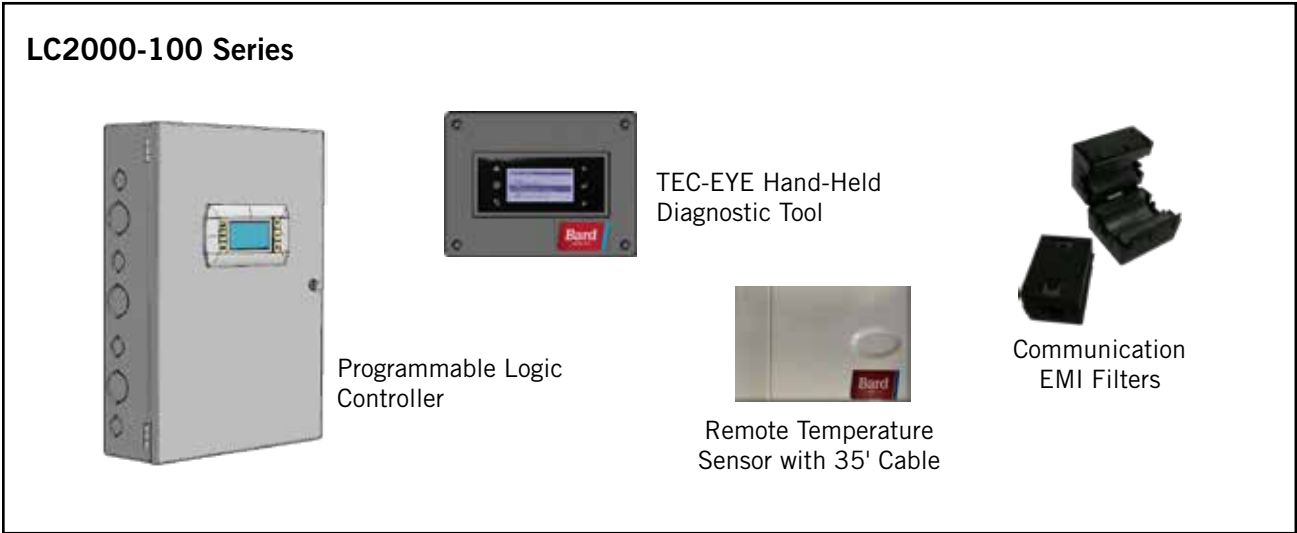

The equipment covered in this manual is to be installed by trained, experienced service and installation technicians.

The refrigerant system is completely assembled and charged. All internal wiring is complete.

The unit is designed for use with or without duct work. Flanges are provided for attaching the supply and return ducts.

These instructions explain the recommended method to install the air cooled self-contained unit and the electrical wiring connections to the unit.

These instructions and any instructions packaged with any separate equipment required to make up the entire air conditioning system should be carefully read before beginning the installation. Note particularly "Starting Procedure" and any tags and/or labels attached to the equipment.

While these instructions are intended as a general recommended guide, they do not supersede any national and/or local codes in any way. Authorities having jurisdiction should be consulted before the installation is made. See **ADDITIONAL PUBLICATIONS** for information on codes and standards.

Sizing of systems for proposed installation should be based on heat loss calculation made according to methods of Air Conditioning Contractors of America (ACCA). The air duct should be installed in accordance with the *Standards of the National Fire Protection Association for the Installation of Air Conditioning and Ventilating Systems of Other Than Residence Type, NFPA No. 90A, and Residence Type Warm Air Heating and Air Conditioning Systems, NFPA No. 90B*. Where local regulations are at a variance with instructions, installer should adhere to local codes.

Shipping Damage

Upon receipt of equipment, the cartons should be checked for external signs of shipping damage. If damage is found, the receiving party must contact the last carrier immediately, preferably in writing, requesting inspection by the carrier's agent.

These units must remain in upright position at all times.

ADDITIONAL PUBLICATIONS

These publications can help when installing the furnace. They can usually be found at the local library or purchased directly from the publisher. Be sure to consult the current edition of each standard.

National Electrical Code.....ANSI/NFPA 70
Standard for the Installation of Air Conditioning and Ventilating SystemsANSI/NFPA 90A
Standard for Warm Air Heating and Air Conditioning SystemsANSI/NFPA 90B
Load Calculation for Residential Winter and Summer Air Conditioning ACCA Manual J
Duct Design for Residential Winter and Summer Air Conditioning and Equipment Selection ACCA Manual D

For more information, contact these publishers:

Air Conditioning Contractors of America (ACCA)
1712 New Hampshire Ave. N.W.
Washington, DC 20009
Telephone: (202) 483-9370
Fax: (202) 234-4721

American National Standards Institute (ANSI)
11 West Street, 13th Floor
New York, NY 10036
Telephone: (212) 642-4900
Fax: (212) 302-1286

American Society of Heating, Refrigeration and Air Conditioning Engineers, Inc. (ASHRAE)
1791 Tullie Circle, N.E.
Atlanta, GA 30329-2305
Telephone: (404) 636-8400
Fax: (404) 321-5478

National Fire Protection Association (NFPA)
Batterymarch Park
P. O. Box 9101
Quincy, MA 02269-9901
Telephone: (800) 344-3555
Fax: (617) 984-7057

ANSI Z535.5 Definitions:

Danger: Indicate[s] a hazardous situation which, if not avoided, will result in death or serious injury. The signal word “DANGER” is to be limited to the most extreme situations. DANGER [signs] should not be used for property damage hazards unless personal injury risk appropriate to these levels is also involved.

Warning: Indicate[s] a hazardous situation which, if not avoided, could result in death or serious injury. WARNING [signs] should not be used for property damage hazards unless personal injury risk appropriate to this level is also involved.

Caution: Indicate[s] a hazardous situation which, if not avoided, could result in minor or moderate injury. CAUTION [signs] without a safety alert symbol may be used to alert against unsafe practices that can result in property damage only.

Notice: [this header is] preferred to address practices not related to personal injury. The safety alert symbol shall not be used with this signal word. As an alternative to “NOTICE” the word “CAUTION” without the safety alert symbol may be used to indicate a message not related to personal injury.



WARNING

Electrical shock hazard.

Have a properly trained individual perform these tasks.

Failure to do so could result in electric shock or death.

WARNING

Fire hazard.

Maintain minimum 1/4” clearance between the supply air duct and combustible materials in the first 3’ feet of ducting.

Failure to do so could result in fire causing damage, injury or death.

WARNING

Heavy item hazard.

Use more than one person to handle unit.

Failure to do so could result in unit damage or serious injury.

CAUTION

Cut hazard.

Wear gloves to avoid contact with sharp edges.

Failure to do so could result in personal injury.

SECTION 1:

INSTALLATION

INSTRUCTIONS

LIST OF NECESSARY MATERIALS/TOOLS

Additional hardware and miscellaneous supplies are needed for installation. These items are field supplied and must be sourced before installation. This list also includes tools needed for installation.

LIST OF MATERIALS/TOOLS

- Personal protective equipment/safety devices
- Supply/return grilles
- Field-fabricated sleeves (if necessary)
- Fasteners sufficient for mounting the units such as 5/16" diameter anchor/carriage/lag bolts
- 7/8" diameter washers
- Caulking materials
- Miscellaneous hand and power tools and jobsite or shop materials
- Lifting equipment with the necessary capacity and rigging to safely move/install the systems
- Electrical supplies
 - Two (2) 20A circuit breakers for the shelter DC power plant (one per wall-mount unit)
 - One (1) 5A circuit breaker for the shelter DC power plant (for the Bard-Link™ controller)
 - Two (2) various size circuit breakers for the shelter AC breaker box (see Table 1.1: Electrical Specifications on page 15)
 - High-voltage wire of various gauges (see Table 1.1)
 - Communication wire: 2-wire, 18 gauge, shielded with drain
 - 18 gauge non-shielded wire for connecting smoke detector, hydrogen detector and/or generator, if applicable, to controller
- CAT 6 Ethernet cable of field-determined length (for remote communication, if applicable)
- Miscellaneous electrical supplies including rigid/flexible conduit and fittings, junction boxes, wire connectors and supports

NOTICE

The following are required and must be sourced prior to installation of these units.

- Two (2) 20A circuit breakers for the shelter DC power plant (one per wall-mount unit)
- One (1) 5A circuit breaker for the shelter DC power plant (for the Bard-Link™ controller)

Circuit breakers for Emerson Network Power (ENP) power plants (used in most telecomm shelters built today) are available directly through the following distributors:

- Emerson Network Power: 440.288.1122
- Master Electronics: 888.473.5297 or www.onlinecomponents.com

Emerson Network Power (ENP) Part Numbers

- 20A circuit breaker: P/N 101601
- 5A circuit breaker: P/N 101598

Always confirm the application before ordering.

FIGURE 1.1
D-Series DUAL-TEC™ Wall-Mount Unit Model Nomenclature

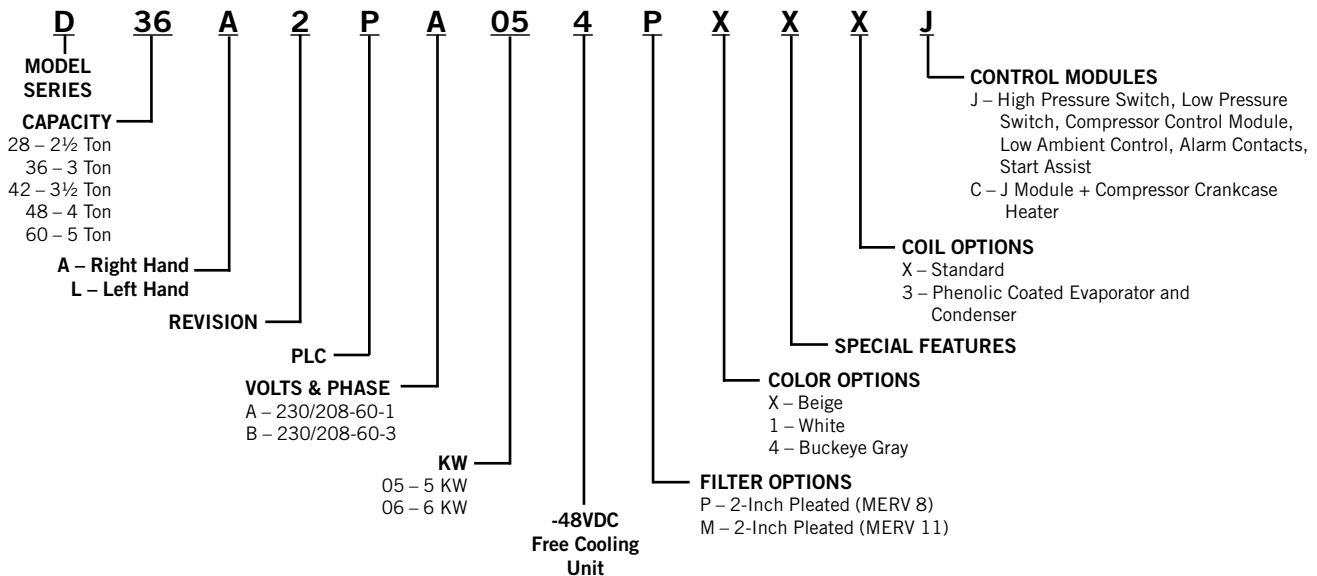

NEW SHELTER INSTALLATION VS. RETROFIT INSTALLATION

These installation instructions cover both new shelter installations and retrofit installations. Each installation is unique and may require special accommodations and modifications. Although Bard Manufacturing follows a long-established tradition of manufacturing equipment using industry standard dimensions for building penetration, it is occasionally necessary to move or enlarge supply and return openings when replacing non-standardized equipment in a retrofit application.

MINIMUM CLEARANCE

D-Series wall-mount air conditioners are available in both right-hand access models and left-hand access models. Right-hand access models have the heat strip access panel, external circuit breakers access panel and internal controls access panel on the right side of the unit. Left-hand access models are a mirror image of the right-hand access models, and allow two wall-mount units to be placed in relatively close proximity and yet still allow complete access for maintenance and repair.

On side-by-side installations, maintain a minimum of 26" clearance on control side to allow access to control panel and heat strips, and to allow proper airflow to the outdoor coil. For installations where units are installed with both control panels facing each other (inward), maintain a minimum of 36" clearance to allow access. Additional clearance may be required to meet local or national codes.

Care should be taken to ensure that the recirculation and obstruction of condenser discharge air does not occur. Recirculation of condenser discharge air can be from either a single unit or multiple units. Any object such as shrubbery, a building or a large object can cause obstructions to the condenser discharge air. Recirculation or reduced airflow caused by obstructions will result in reduced capacity, possible unit pressure safety lockouts and reduced unit service life.

For units with blow through condensers, such as the D-Series units, it is recommended there be a minimum distance of 10' between the front of the unit and any barrier or 20' between the fronts of two opposing (facing) units.

Clearances Required for Service Access and Adequate Condenser Airflow

MODELS	LEFT SIDE	RIGHT SIDE
All covered by this manual	26"	26"
Units with control panels facing each other (inward)	36" between units	

CLEARANCE TO COMBUSTIBLES

WARNING

Fire hazard.

Maintain minimum 1/4" clearance between the supply air duct and combustible materials in the first 3' of ducting.

Failure to do so could result in fire causing damage, injury or death.

The unit itself is suitable for 0" clearance, but the supply air duct flange and the first 3' of supply air duct require a minimum of 1/4" clearance to combustible material. However, it is generally recommended that a 1" clearance is used for ease of installation and maintaining the required clearance to combustible material. See Figure 1.3 on page 12 for details on opening sizes.

Minimum Clearances Required to Combustible Materials

MODELS	SUPPLY AIR DUCT FIRST 3'	CABINET
All covered by this manual	1/4"	0"

MODEL IDENTIFICATION

Identify the specific model using the model nomenclature information found in Figure 1.1 and/or model/serial tag found on the unit on the opposite side of the control and access panels. See Figure 1.2 on page 10 for dimensions and critical installation requirements.

WALL-MOUNT UNIT INSTALLATION

MOUNTING THE UNITS

WARNING

Heavy item hazard.

Use more than one person to handle unit.

Failure to do so could result in unit damage or serious injury.

NOTE: It may be best to spot some electrical knockouts (such as those located on the back of the wall-mount unit) before units are mounted and access is unavailable or limited (see Figure 1.2 to locate pre-punched knockouts).

Two holes for the supply and return air openings must be cut through the wall as shown in Figure 1.3 on page 12. On wood frame walls, the wall construction must be strong and rigid enough to carry the weight of the unit without transmitting any unit vibration. Concrete block walls must be thoroughly inspected to insure that they are capable of carrying the weight of the installed unit.

In retrofit (unit replacement) installations, the openings cut for the original equipment may not line up exactly with needs of this installation. Modifications may need to be made, such as increasing or decreasing the size of the wall cutouts. The existing bolt placement may not line up in which case the original bolts would need to be removed or cut away.

1. These units are secured by wall mounting flanges which secure the unit to the outside wall surface at both sides. A bottom mounting bracket, attached to skid for shipping, is provided for ease of installation, but is not required.
2. The unit itself is suitable for 0" clearance, but the supply air duct flange and the first 3' of supply air duct require a minimum of 1/4" clearance to combustible material. However, it is generally recommended that a 1" clearance is used for ease of installation and maintaining the required clearance to combustible material. See Figure 1.3 for details on opening sizes.
3. Locate and mark lag bolt locations and location for optional bottom mounting bracket, if desired (see Figure 1.3).
4. Mount bottom mounting bracket (if used).

5. If desired, hook top rain flashing (attached to front-right of supply flange for shipping) under back bend of top.
6. Position unit in opening and secure with fasteners sufficient for the application such as 5/16" lag/anchor/carriage bolts; use 7/8" diameter flat washers on the bolts. It is recommended that a bead of silicone caulking be placed behind the side mounting flanges.
7. Secure optional rain flashing to wall and caulk across entire length of top (see Figure 1.3).
8. For additional mounting rigidity, the return air and supply air frames or collars can be drilled and screwed or welded to the structural wall itself (depending upon wall construction). Be sure to observe required clearance if combustible wall.
9. A plastic drain hose extends from the drain pan at the top of the unit down to the unit base. There are openings in the unit base for the drain hose to pass through. In the event the drain hose is connected to a drain system of some type, it must be an open or vented type system to assure proper drainage.

FIGURE 1.3
Mounting Instructions

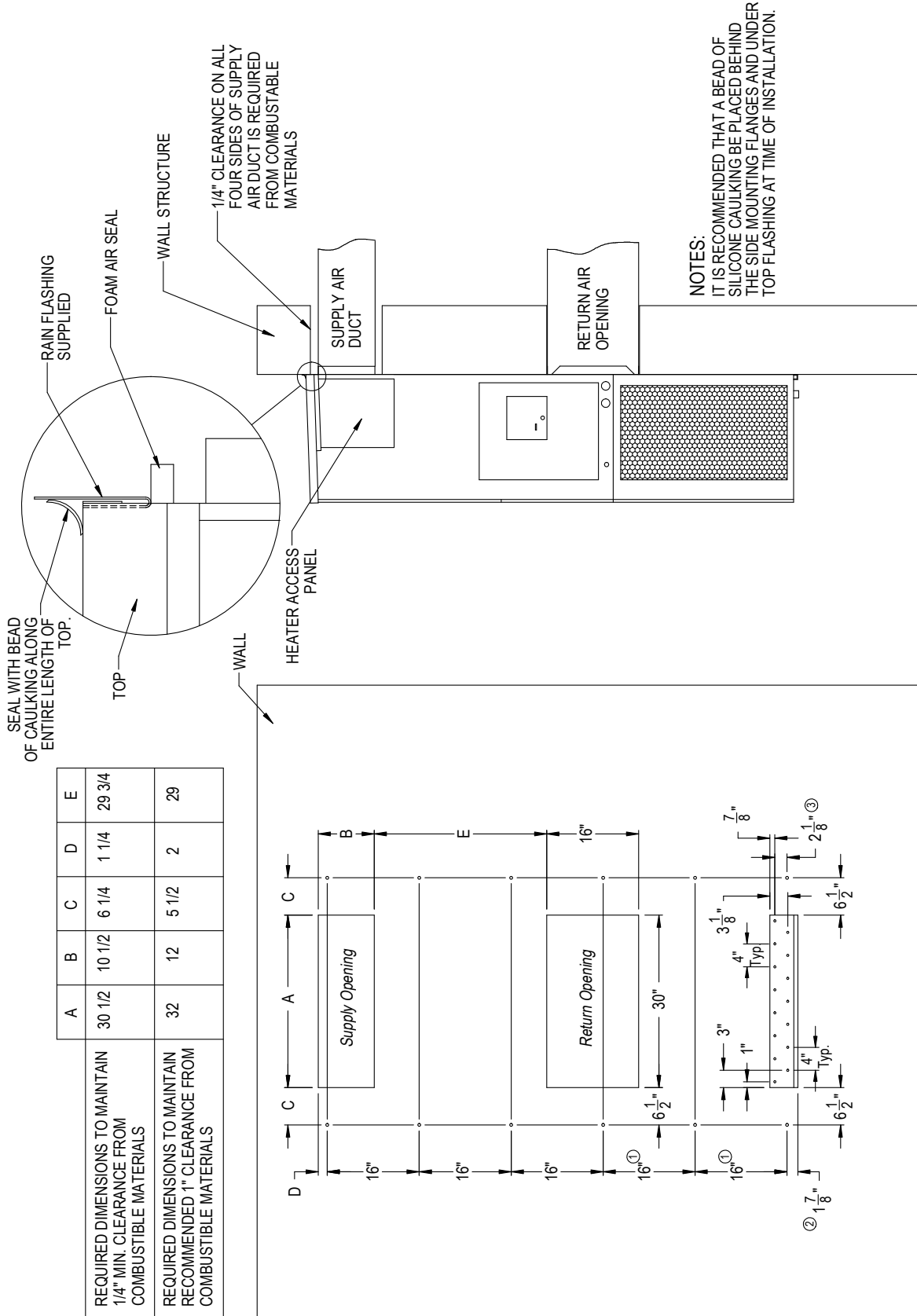

FIGURE 1.4
Electric Heat Clearance

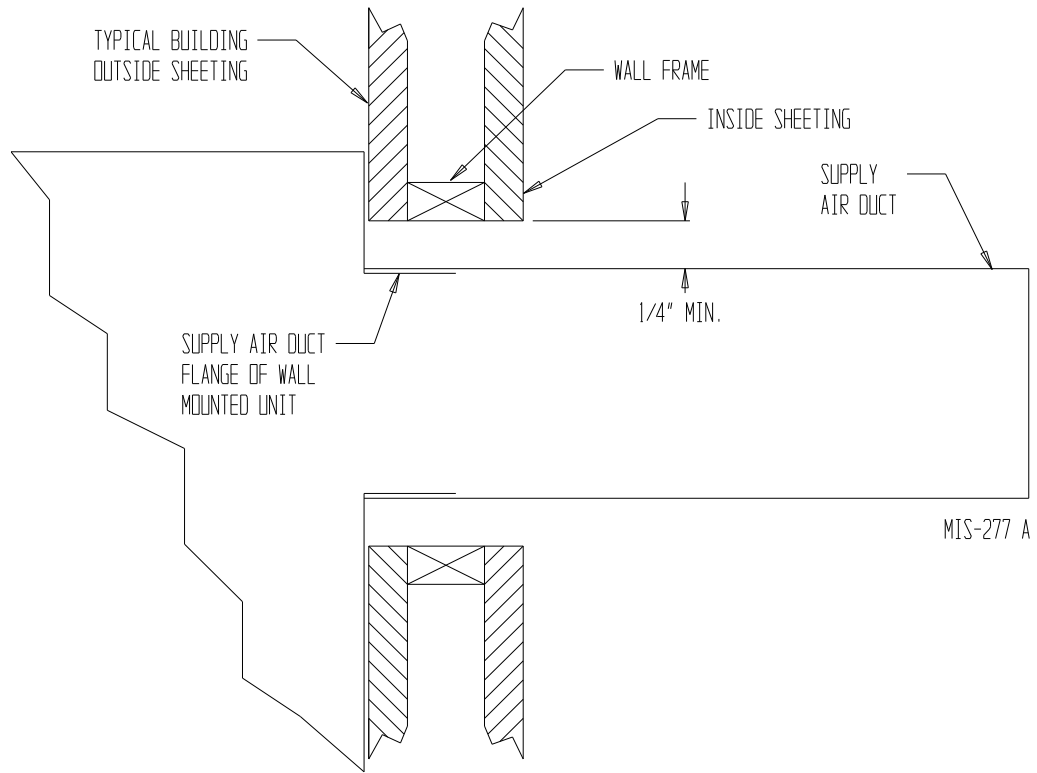

FIGURE 1.5
Wall Mounting Instructions

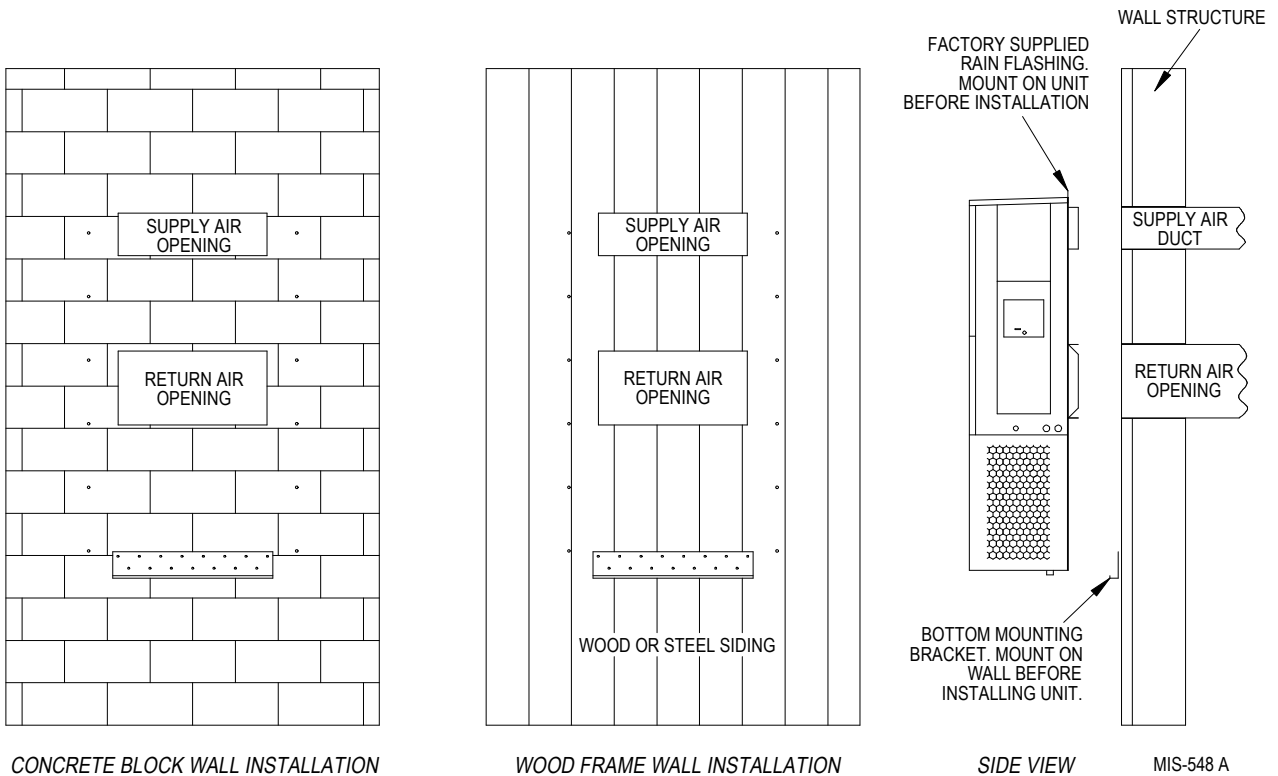

FIGURE 1.6
Wall Mounting Instructions

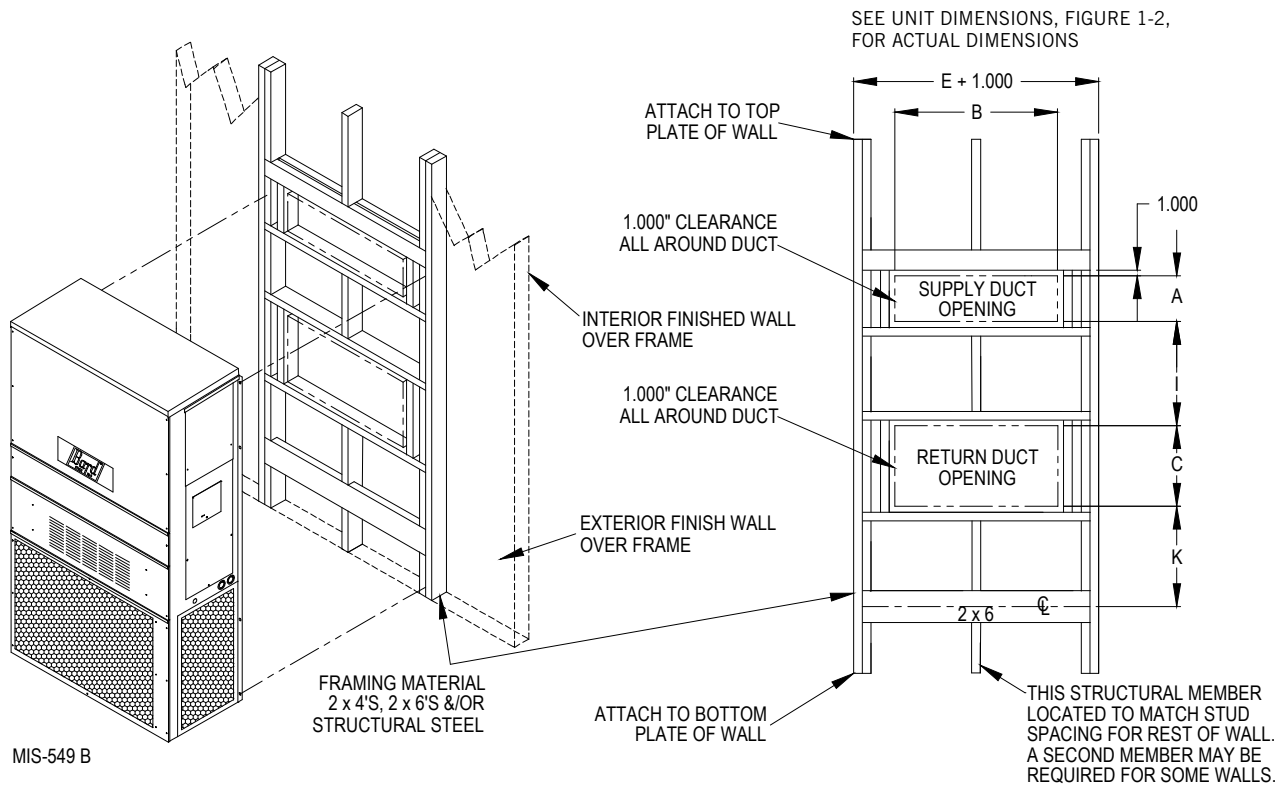
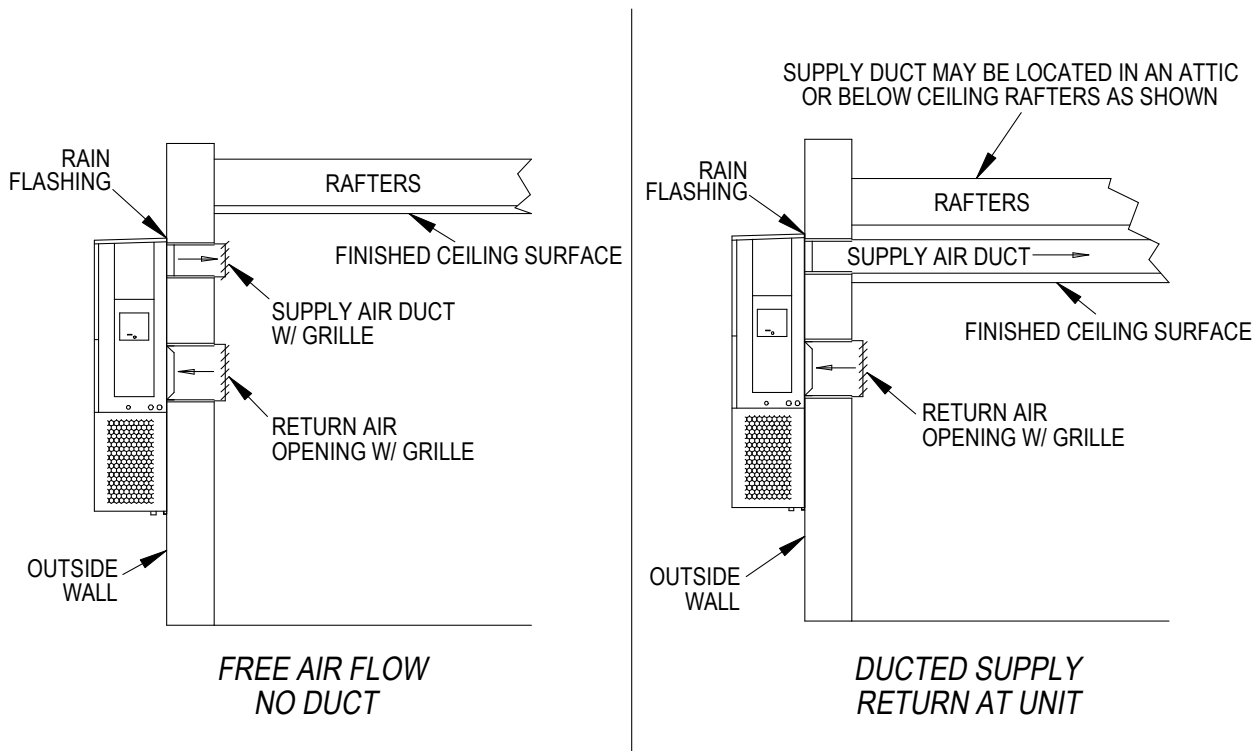

FIGURE 1.7
Common Wall Mounting Installations



WALL-MOUNT UNIT SUPPLY WIRING

NOTICE

All models covered by this installation instruction require dual power sources: **VAC utility power** to run the compressor, heat and outdoor fan motor and **-48 VDC power** to operate the indoor blower and DC free cooling damper.

These units require a positive ground -48 VDC copper conductor field wire connection. Refer to the unit wiring diagram for more information.

WARNING

Electrical shock hazard.

Have a properly trained individual perform these tasks.

Failure to do so could result in electric shock or death.

Refer to the unit rating plate or Table 1.1 for wire sizing information and maximum fuse or circuit breaker size. Each outdoor unit is marked with a “Minimum Circuit Ampacity”. The field wiring used must be sized to carry that amount of current. All models are suitable only for connection with copper wire. Each unit and/or wiring diagram will be marked “Use Copper Conductors Only”. These instructions **must be** adhered to. Refer to the National Electrical Code (NEC) for complete current carrying capacity data on the various insulation grades of wiring material. All wiring must conform to NEC and all local codes.

TABLE 1.1
Electrical Specifications

Model	Rated Volts, Hertz & Phase	AC POWER CIRCUIT			DC POSITIVE GROUND POWER CIRCUIT		
		Minimum Circuit Ampacity	Maximum External Fuse or Ckt. Breaker	Field Power/ Ground Wire Size	Minimum Circuit Ampacity	Maximum External Fuse or Ckt. Breaker	Field Power/ Ground Wire Size
D28A2PA05/D28L2PA05	208/230-60-1	26	30	10	15.6	20	12
D28A2PB06/D28L2PB06	208/230-60-3	18	20	12	15.6	20	12
D36A2PA05/D36L2PA05	208/230-60-1	26	40	8	15.6	20	12
D36A2PB06/D36L2PB06	208/230-60-3	18	25	10	15.6	20	12
D42A2PA05/D42L2PA05	208/230-60-1	26	40	8	15.6	20	12
D42A2PB06/D42L2PB06	208/230-60-3	20	25	10	15.6	20	12
D48A2PA05/D48L2PA05	208/230-60-1	30	50	8	15.6	20	12
D48A2PB06/D48L2PB06	208/230-60-3	20	30	10	15.6	20	12
D60A2PA05/D60L2PA05	208/230-60-1	36	60	6	15.6	20	12
D60A2PB06/D60L2PB06	208/230-60-3	30	40	8	15.6	20	12

These “Minimum Circuit Ampacity” values are to be used for sizing the field power conductors. Refer to the National Electric Code (latest version), Article 310 for power conductor sizing.

CAUTION: When more than one field power circuit is run through one conduit, the conductors must be derated. Pay special attention to note 8 of Table 310 regarding Ampacity Adjustment Factors when more than three current carrying conductors are in a raceway.

Maximum size of the time delay fuse or circuit breaker for protection of field wiring conductors.

Based on 75°C copper wire. All wiring must conform to the National Electric Code and all local codes.

The electrical data lists fuse and wire sizes (75°C copper) for all models including the most commonly used heater sizes. Also shown are the number of field power circuits required for the various models with heaters.

The unit rating plate lists a “Maximum Time Delay Relay Fuse” or circuit breaker that is to be used with the equipment. The correct size must be used for proper circuit protection and also to assure that there will be no nuisance tripping due to the momentary high starting current of the compressor motor.

Route all field wires to the right of the wire shield as shown in the circuit routing label found in Figure 1.8 (and also on the wall-mount units).

FIGURE 1.8
Circuit Routing Label

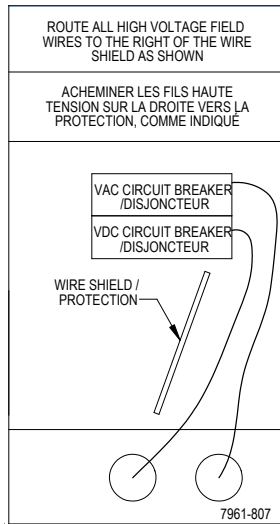

See Figure 1.9 to reference VAC landing points and Figure 1.11 to reference VDC landing points.

The disconnect access door on this unit may be locked to prevent unauthorized access to the disconnect. To convert for the locking capability, bend the tab located in the bottom left-hand corner of the disconnect opening under the disconnect access panel straight out. This tab will now line up with the slot in the door. When shut, a padlock may be placed through the hole in the tab preventing entry.

FIGURE 1.9
VAC Supply Wiring Landing Points

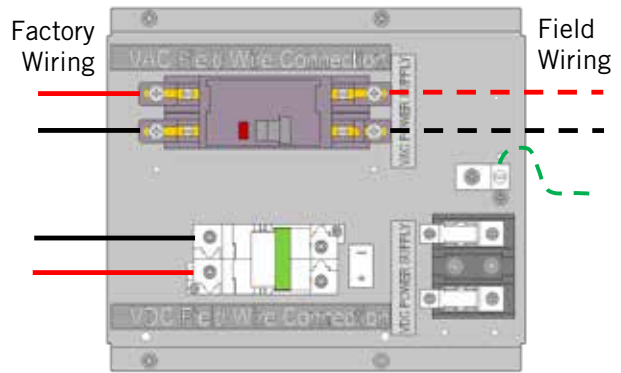

NOTE: Right-hand access model wiring landing points are shown here; left-hand access models will mirror this image.

IMPORTANT

230/208V 1 phase and 3 phase equipment use dual primary voltage transformers. All equipment leaves the factory wired on 240V tap. **It is very important that the correct voltage tap is used.** For 208V operation, reconnect from 240V to 208V tap (see Figure 1.10). The acceptable operating voltage range for the 240 and 208V taps are: 240V Tap (253 – 216) and 208 Tap (220 – 197).

FIGURE 1.10
Adjusting the 230/208 VAC Transformer

It is very important that the correct voltage tap (240V or 208V) is used

1. Verify incoming AC voltage: Multimeter set to VAC

2. If incoming AC voltage is 220VAC or above...

...do not adjust transformer

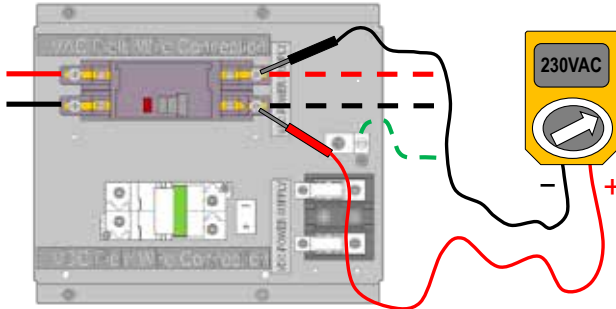

Shelter supply breaker in ON position
 Bard system breaker in OFF position

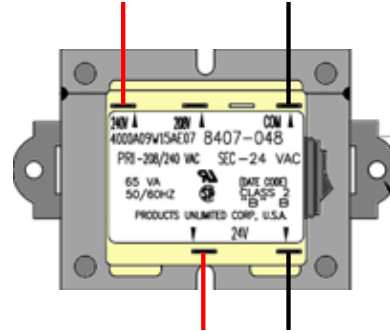

3. If incoming AC voltage is below 220VAC...

...shut off AC breaker to unit

and move factory "240V" wire to "208V" terminal

230V/208V Single Phase Voltage Range:
197VAC – 253VAC

230V/208V Three Phase Voltage Range:
197VAC – 253VAC
 (not shown)

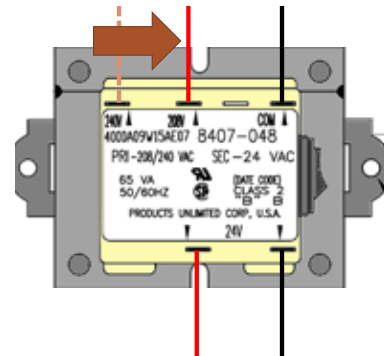
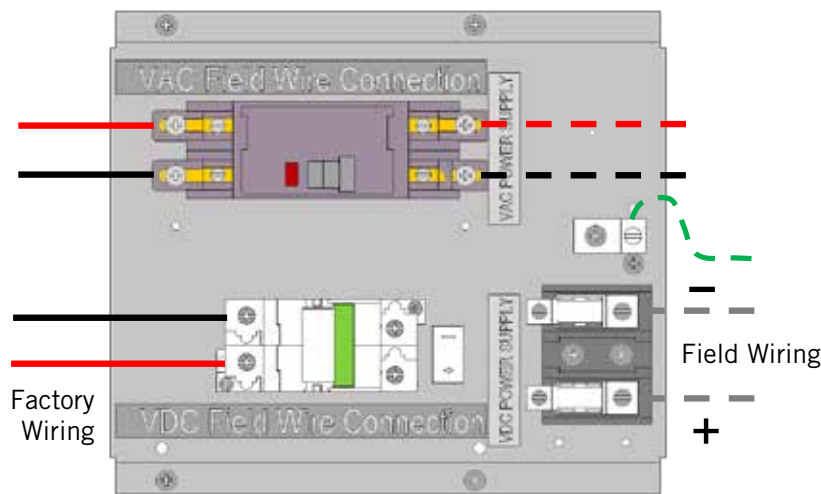

FIGURE 1.11
VDC Supply Wiring Landing Points



NOTE: Right-hand access model wiring landing points are shown here; left-hand access models will mirror this image.

FIGURE 1.12
Bard Polarity-Voltage Monitor



If the VDC wiring is not terminated correctly on the specific polarity-indicated terminals of the VDC terminal block, the VDC controls and motors will not activate and the wall-mounted unit will not function.

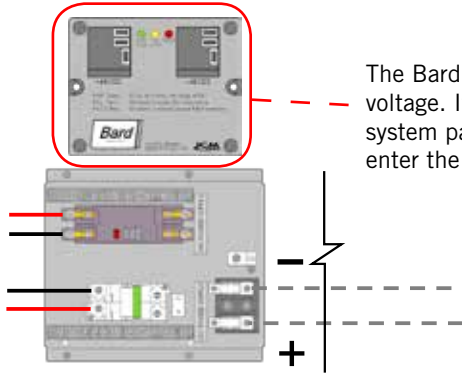

The Bard Polarity-Voltage Monitor continually monitors for correct polarity and voltage. If field wiring is connected improperly, or the voltage is outside of the system parameters, the Polarity-Voltage Monitor will not allow any VDC voltage to enter the system, protecting the internal controls and equipment.

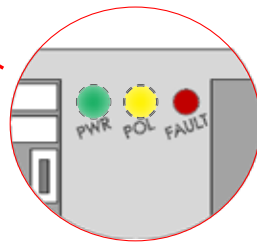
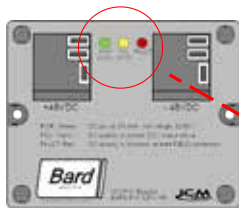

When field wiring is correct in voltage and polarity, the green power (PWR) LED and yellow polarity (POL) LED will light, and system will operate normally.

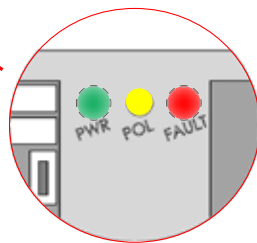
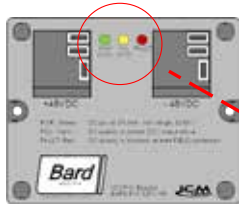

If field wiring is incorrect in polarity, the red FAULT LED will light, and the monitor will not allow VDC voltage into the system.

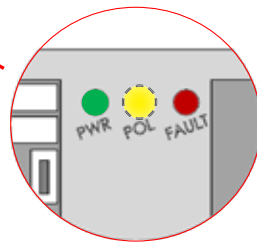
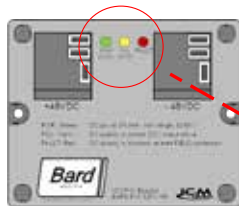

If field wiring is correct in polarity but outside of the required 40VDC – 56VDC, the green PWR LED will not illuminate and the monitor not allow VDC voltage into the system.

If the Polarity-Voltage Monitor is showing a problem with polarity and/or voltage, see pages 65 and 66 of the Service section of this manual for instructions on checking VDC polarity and verifying incoming VDC voltage.

RUNNING IN STAND ALONE (ORPHAN) MODE

With both AC and DC breakers turned on, each D-Series wall-mount system has the capability to run without the PLC controller attached—this feature is called Stand Alone or Orphan Mode, and it basically keeps the shelter between 60°F and 78°F by the use of the factory-installed return air sensor in each wall-mount unit.

During installation, this allows deactivation of one of the two existing, older wall-mount units, while keeping the shelter cool with the other unit still operating. Once the first of the two Bard wall-mount units is installed, Orphan Mode can be enabled early in the installation—keeping the climate inside the shelter stable and the installers comfortable while the remainder of the older equipment is removed and the second Bard wall-mount unit and PLC controller is installed.

Additionally, should either or both D-Series wall-mount units lose communication with the PLC controller (such as during maintenance), they will continue to serve the shelter's needs until a repair can be made.

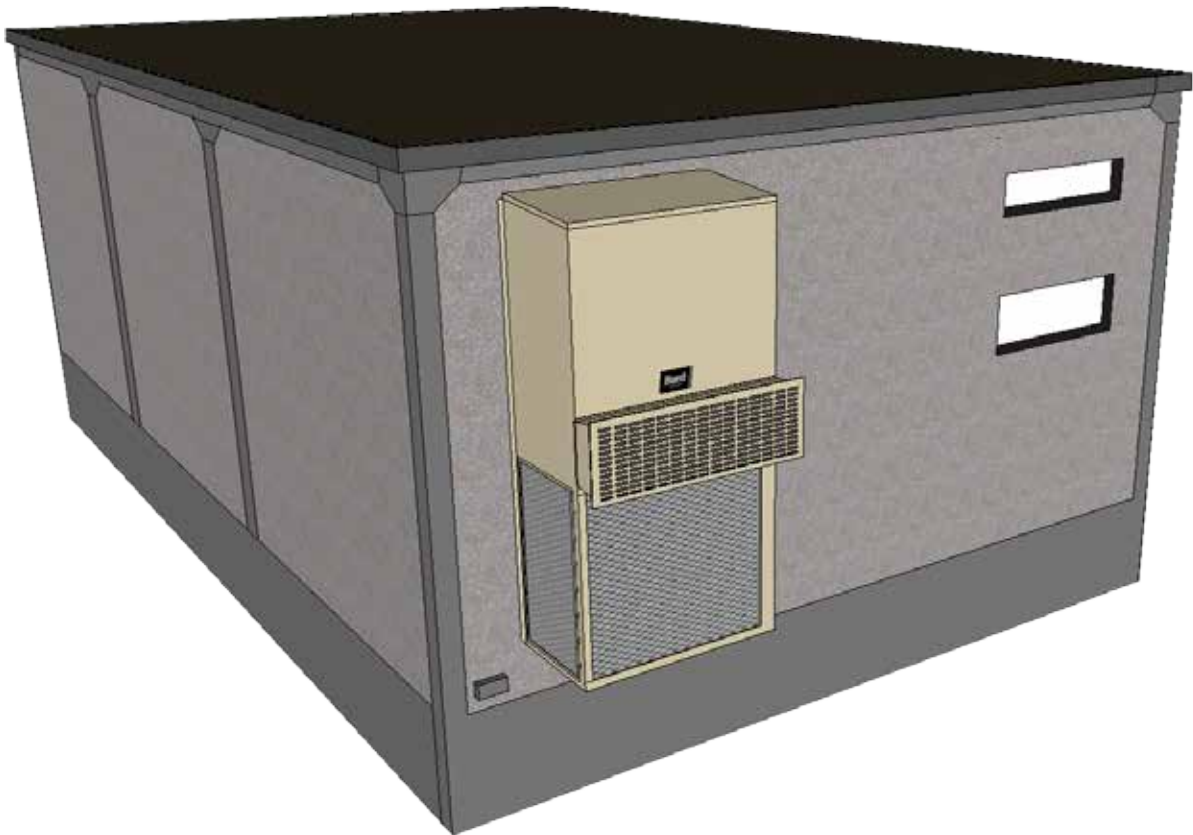

BARD-LINK™ CONTROLLER INSTALLATION

FIGURE 1.13
Typical LC2000 Wiring

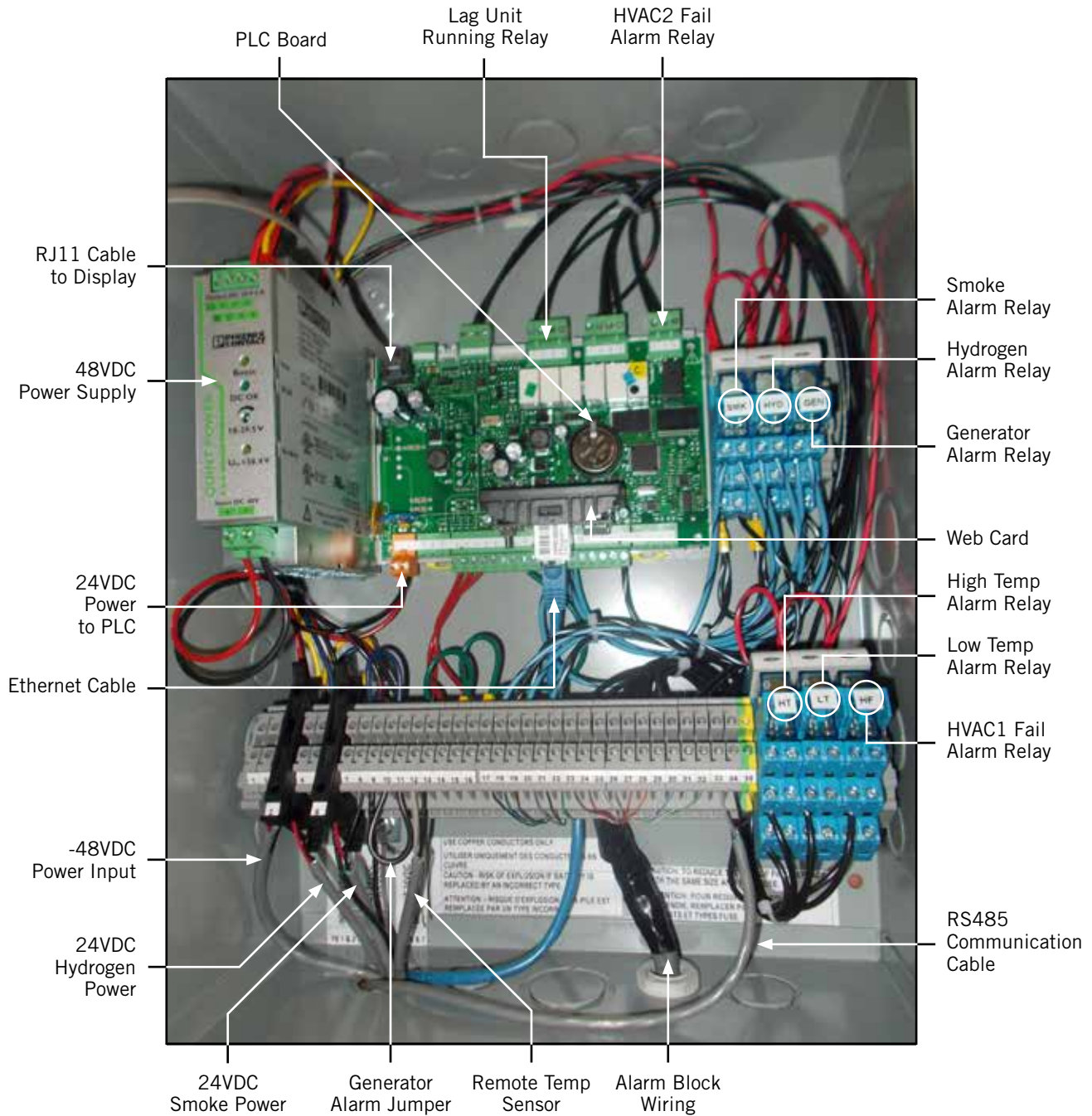

WARNING

Electrical shock hazard.

Disconnect both VAC and VDC power supplies before servicing.

Failure to do so could result in electric shock or death.

LC2000-100 CONTROLLER

The Bard-Link™ LC2000-100 controller is part of the DC Free Cooling Unit system. It is used to control two wall-mount air conditioners from one controller. The microprocessor control provides an easy-to-read interface with large LCD graphical display. It provides total redundancy for the structure and equal wear on both units. The Bard-Link™ controller is configured for lead/lag/lead/lag sequence.

The LC2000-100 controller comes pre-packaged with a TEC-EYE hand-held diagnostic tool, one remote temperature sensor and a pair of communication EMI filters. This controller is meant for new shelter construction only, and should never be used in the field as a retrofit replacement.

Conduit is recommended for all wiring. Use separate conduits for communication and supply wiring.

1. Mounting the Controller

Because the Bard-Link™ controller utilizes a remote temperature sensor as opposed to one located in the controller box, the controller itself can be installed in any indoor location that is suitable, preferably at eye level. Four (4) mounting holes are provided for mounting to the wall and holes for conduit connections are provided in both the base, sides and top of the controller.

2. Installing Remote Indoor Temperature Sensor(s)

A single remote indoor temperature sensor is included with the controller. This sensor must be installed for proper operation. Use the included 35' shielded cable to mount the temperature sensor in a location least likely to be affected by open doors, rack-mounted fans, radiant heat sources, etc. Locating the sensor between both return grilles is often the best location, but every installation is unique. Location height should be approximately 48" above the floor. The sensor should be installed on a 4" by 4" junction box to allow for control wire conduit (see Figure 1.14).

For proper operation, the remote indoor temperature sensors must be configured properly with the controller. If only the single remote indoor temperature sensor supplied with the controller is installed, the configuration setting is

FIGURE 1.14
Remote Indoor Temperature Sensor Installation

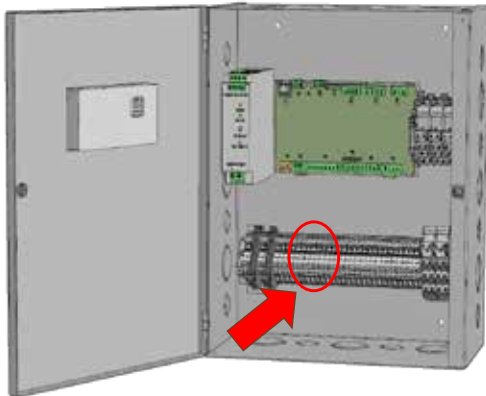

1. Connect wires from provided 35' shielded cable to terminals #11 and #12. The connection is not polarity-sensitive.

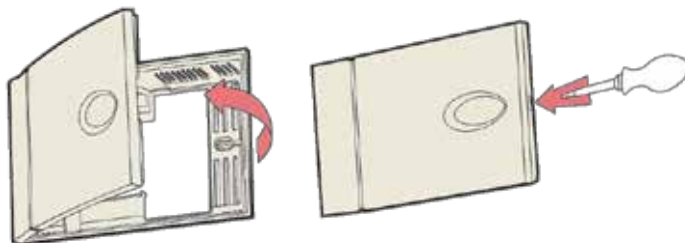
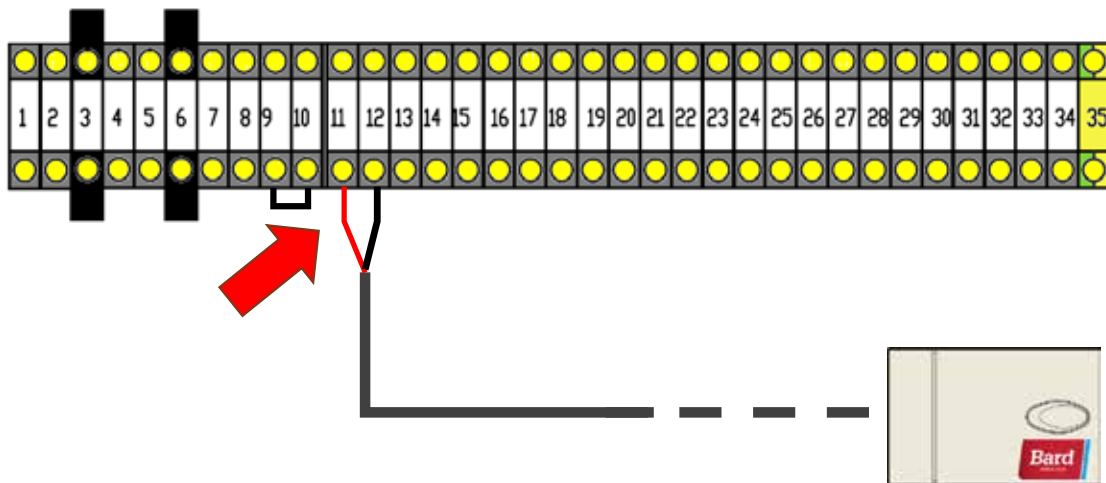

2. Connect the other end of the 35' shielded cable to either of the sensor terminals. These connections are also not polarity sensitive.

Sensor is best mounted on a junction box, and it is recommended that the cable be in conduit.

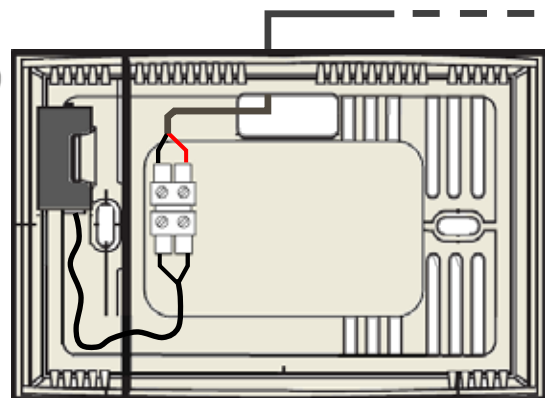

"0". This is the default setting. For information on checking the remote indoor temperature sensor configuration, see **Configuring Additional Remote Indoor Temperature Sensors** on page 49.

For unique situations involving temperature flux within the shelter, up to two (2) additional sensors may be purchased and installed to provide temperature-averaging or highest-temperature protection (see Figure 1.15). Please see **Configuring Additional Remote Indoor Temperature Sensors** on page 49 in the Service section of this manual to set up the additional remotes.

FIGURE 1.15
Additional Remote Temperature Sensor Installation

Up to two (2) additional sensors may be purchased and installed for averaging or highest-temp mode. Use terminals #13, #14, #15 and #16. These connections are not polarity-sensitive.

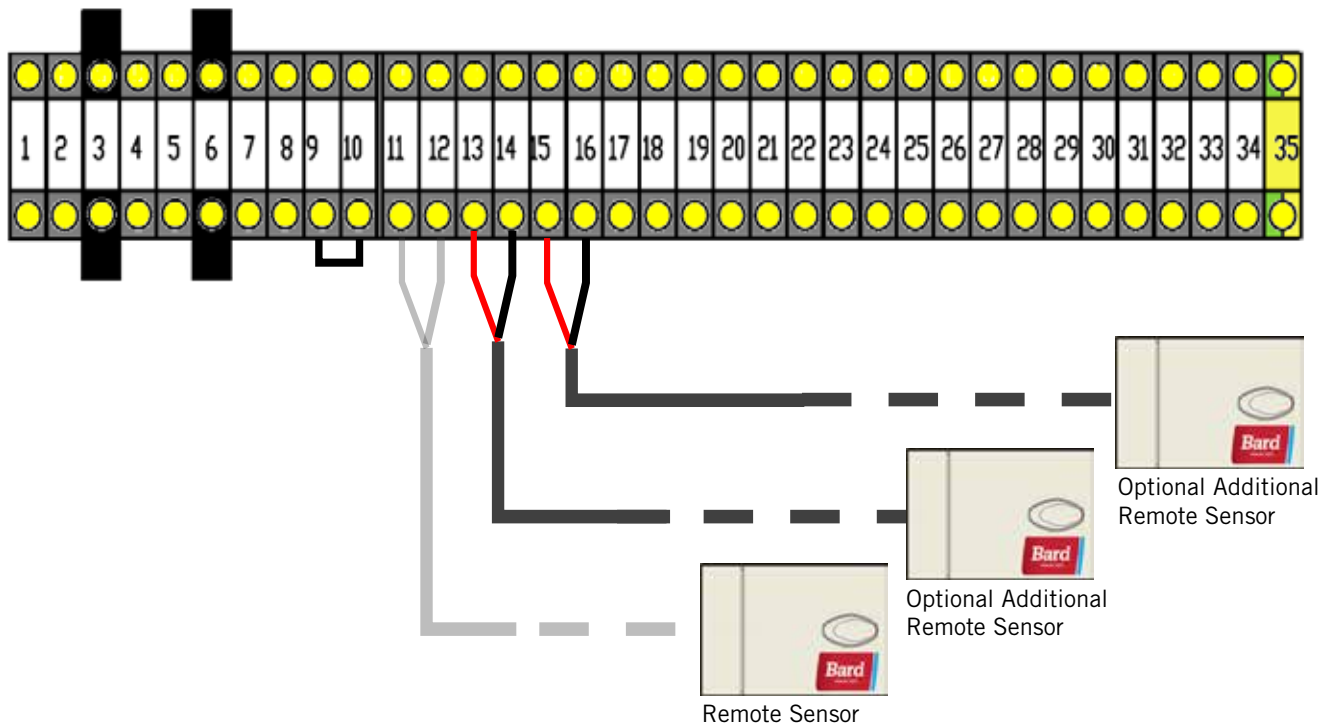

3. Smoke, Hydrogen and Generator Alarms

The LC2000-100 controller has the capacity to provide power to a 24VDC smoke detector and a 24VDC hydrogen detector through fused power supply terminals. Follow the installation instructions provided with each detector for location and mounting practices. For proper power and alarm wiring, review the provided wiring diagrams (see Figures 1.16 and 1.17).

Should the desired NC contact closure need to be changed to the alternative contact closure, please refer to the Service section of this manual to reprogram the PLC control.

The generator run alarm (if desired) will be signaled through a field-provided relay attached to the site generator. The signal from the controller will route through a set of normally closed contacts. Should the generator start, the contacts will open, triggering the alarm and initiating "Generator Run Mode" (both compressors cannot operate concurrently). Since some sites do not have a generator present, there is a factory-installed jumper across terminals #9 and #10. If there is no generator, no action is necessary. If generator run alarm is desired, remove the factory-installed jumper and wire per Figure 1.18.

FIGURE 1.16
Power and Signal Connections for Smoke Detector (If Applicable)

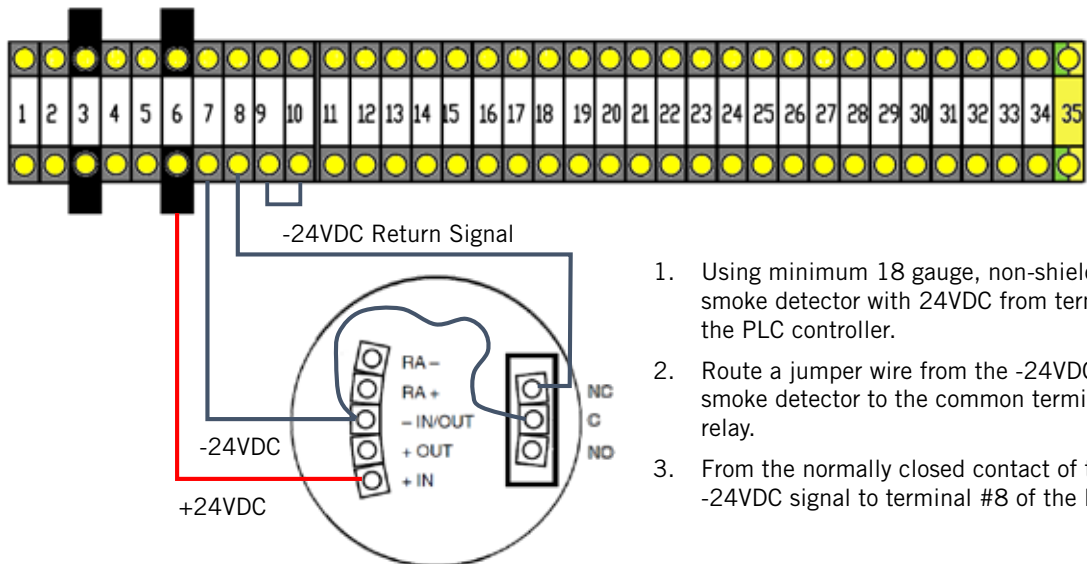
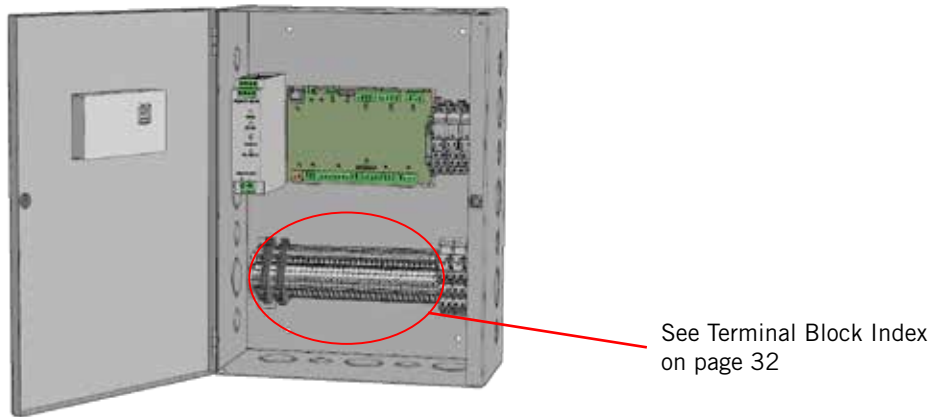

1. Using minimum 18 gauge, non-shielded wire, supply the smoke detector with 24VDC from terminals 6 and 7 of the PLC controller.
2. Route a jumper wire from the -24VDC terminal on the smoke detector to the common terminal of the on-board relay.
3. From the normally closed contact of the relay, return the -24VDC signal to terminal #8 of the PLC controller.

FIGURE 1.17
Power and Signal Connections for Hydrogen Detector (If Applicable)

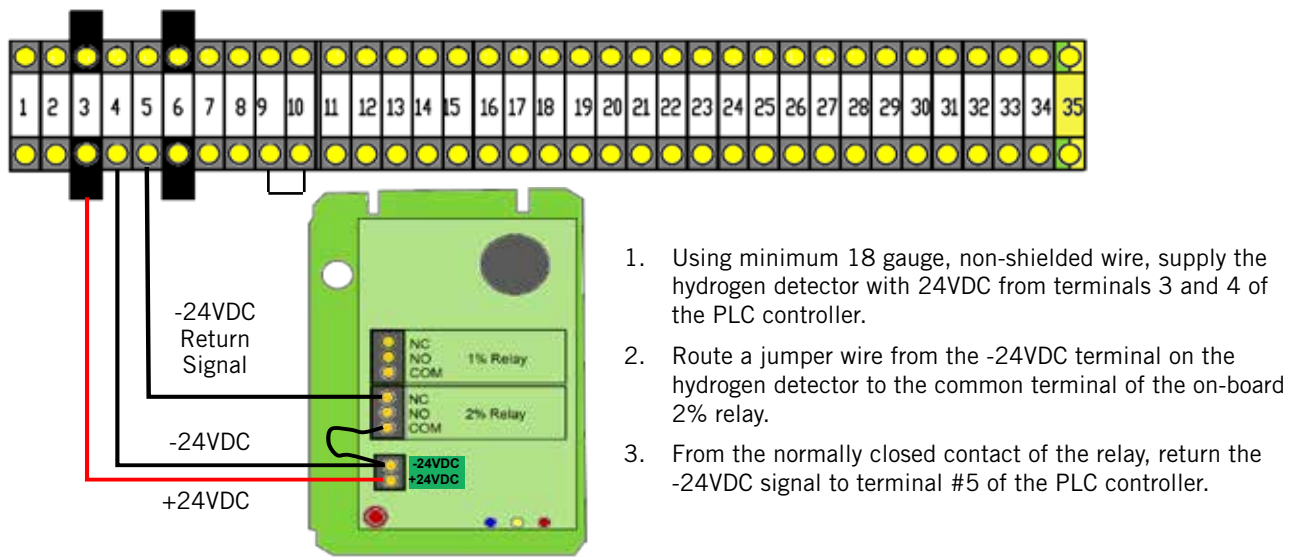
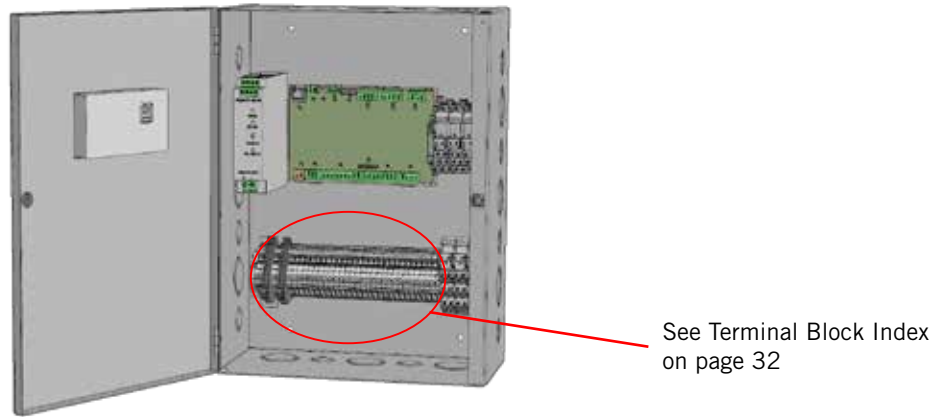
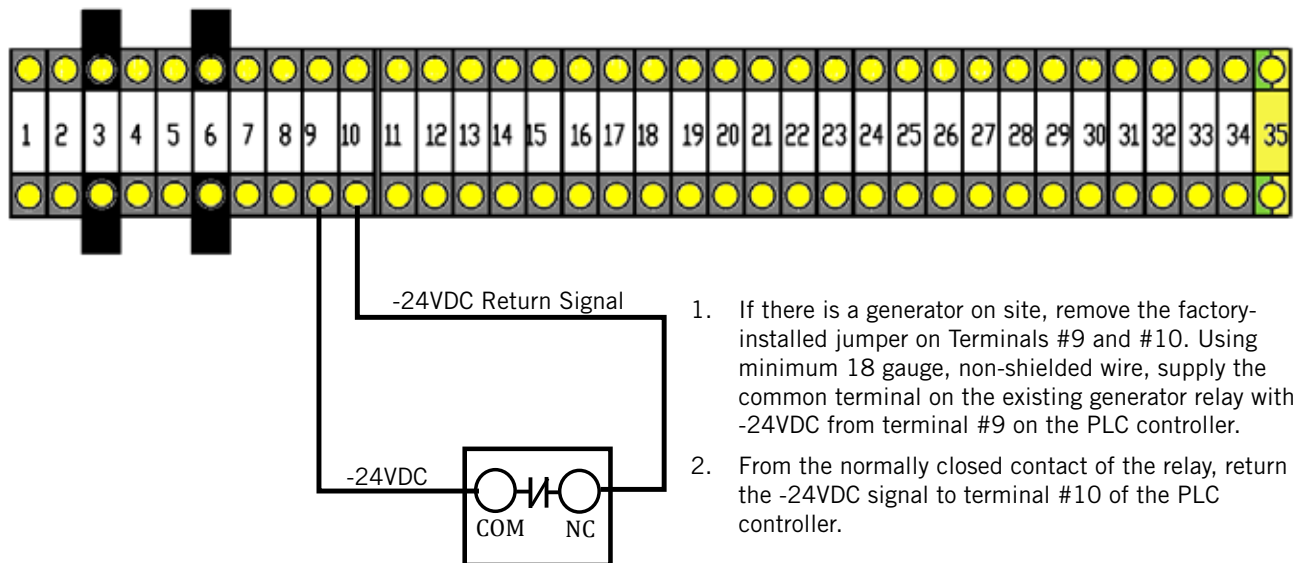

FIGURE 1.18
LC2000-100 Series Generator Run (If Applicable)



4. Connecting External Alarm Points

The LC2000-100 controller has the capability to provide NC contacts for the following eight (8) alarms:

- Smoke
- Generator
- High Temp*
- HVAC 1 Fail
- Hydrogen
- Lag Unit Run
- Low Temp*
- HVAC 2 Fail

The LC2000 provides contacts for alarms at the internal terminal block (see Figure 1.19).

FIGURE 1.19
LC2000-100 External Alarm Wiring

On the terminal strip of the LC2000 controller, there are eight (8) separate series of normally closed **dry contacts** for the following alarms:

- Smoke
- Generator
- High Temp*
- HVAC 1 Fail
- Hydrogen
- Lag Unit Run
- Low Temp*
- HVAC 2 Fail

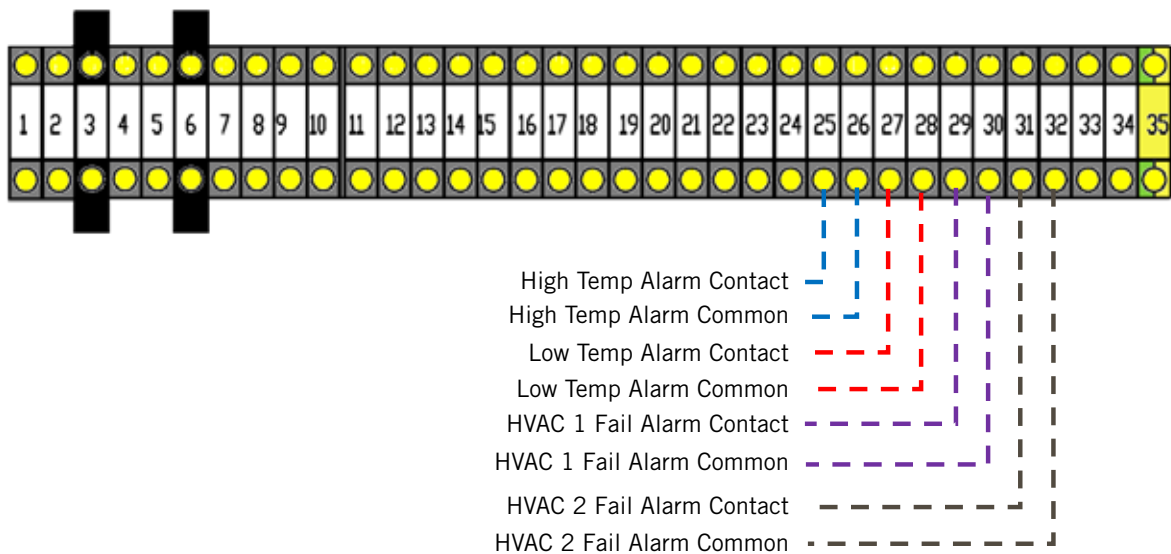
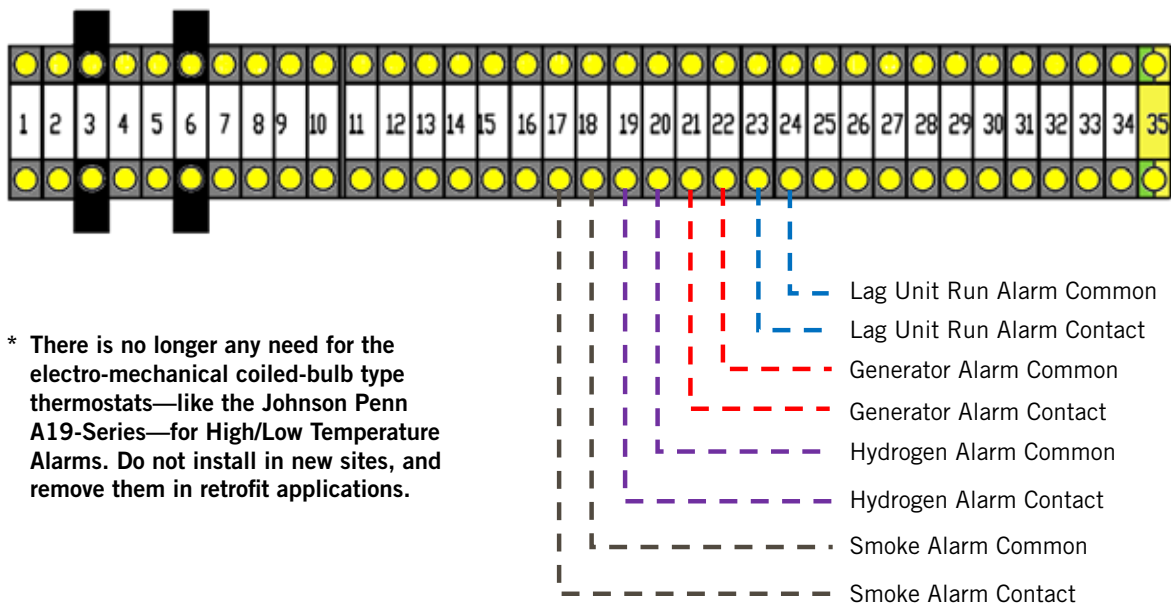

5. Communication Wiring

Connect the communication wiring from the two wall-mount units to the controller in the manner shown in Figure 1.20. The communication wire should be 2-wire, 18 gauge shielded cable with drain. Be sure to match "+" and "-" symbols on controller terminal blocks to prewired unit control terminal block (see Figures 1.22 and 1.23 on pages 29 and 30). Attach communication wire filters as shown in Figure 1.21 on page 28. **Use separate conduits for communication and supply wiring.**

FIGURE 1.20
Communication Wiring

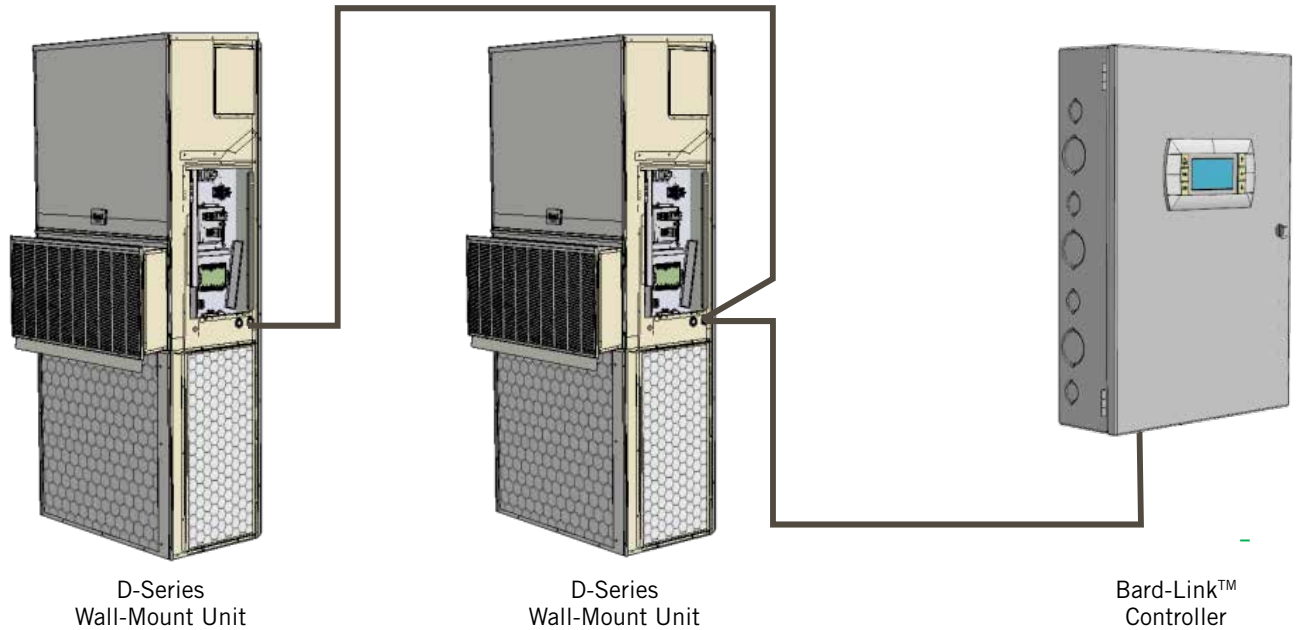
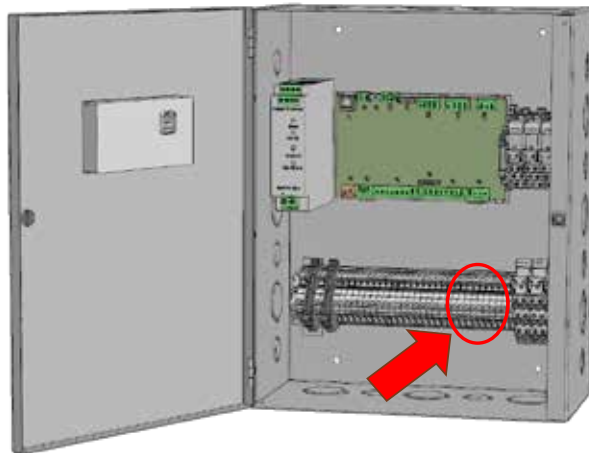
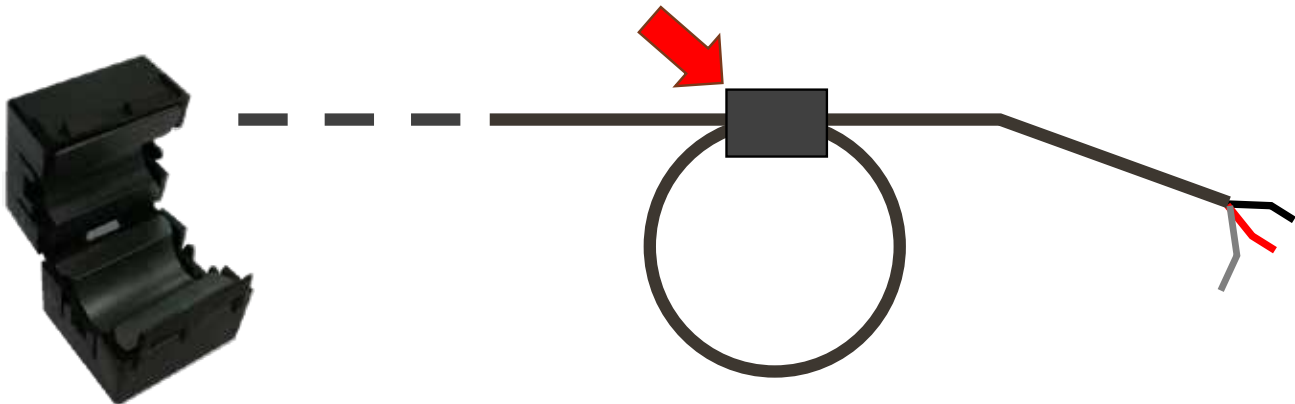

FIGURE 1.21
Communication Wiring: Termination at the Controller



1. Using the field-provided shielded cable, make a small service loop after entering the controller and attach the provided EMI filter at the intersection of the loop.



2. Connect one wire to terminal #33 (negative), the other wire to terminal #34 (positive) and the drain wire to ground terminal #35.

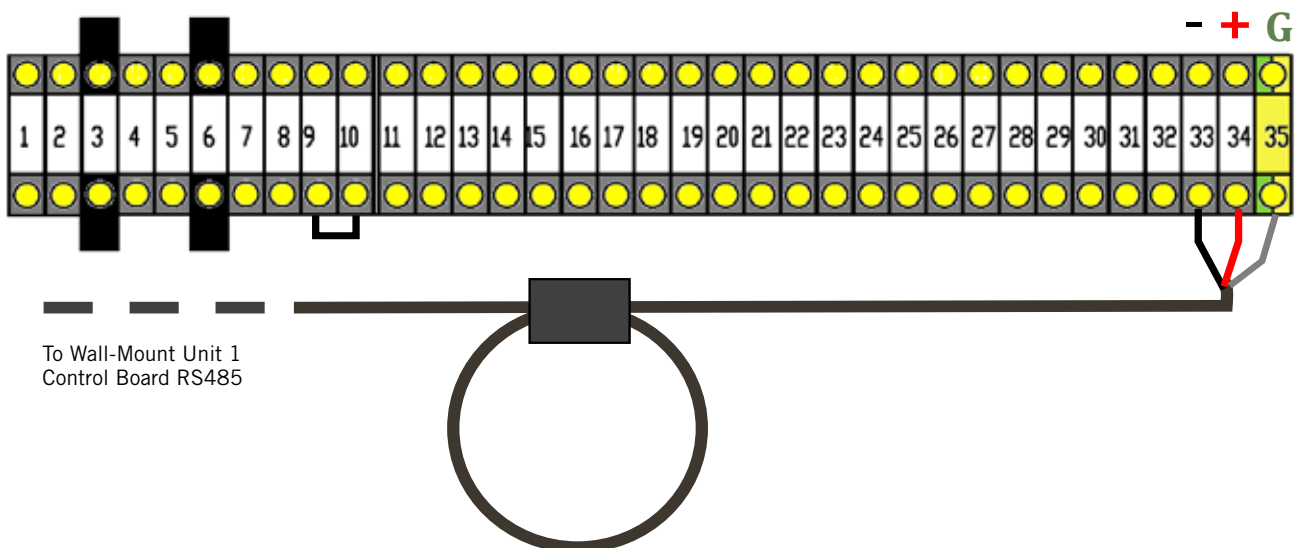
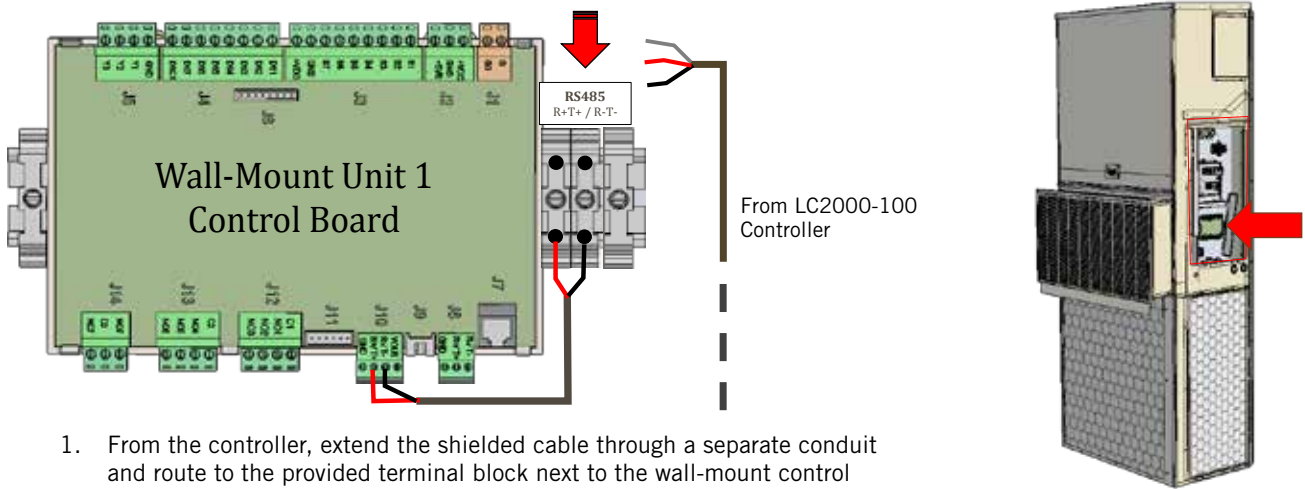
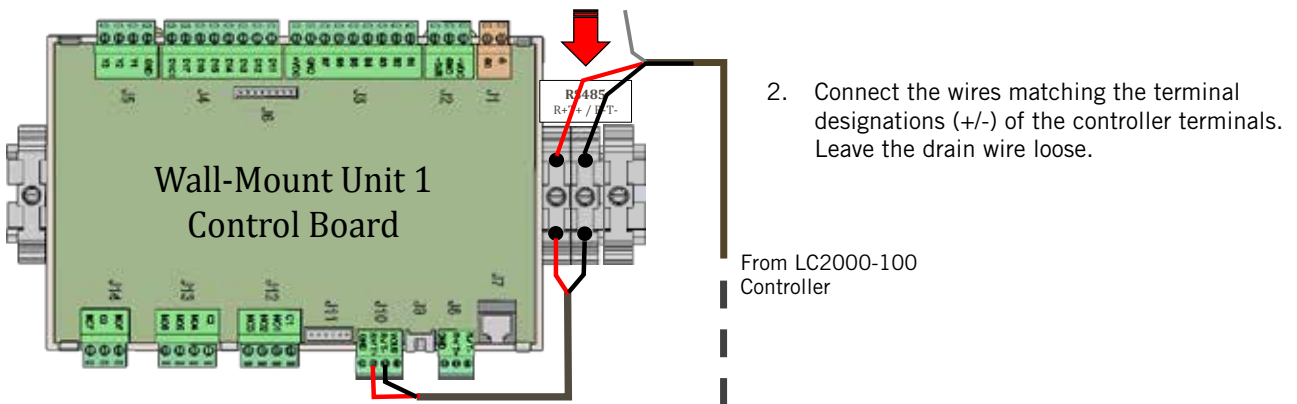

FIGURE 1.22
Communication Wiring: Termination at the First Wall-Mount Unit



1. From the controller, extend the shielded cable through a separate conduit and route to the provided terminal block next to the wall-mount control board.

Note that the terminal block label is clearly marked “+” and “-”. These connections are polarity-sensitive. Two-wire communication from control board is prewired to terminal block. Make sure to match “+” and “-” symbols on controller terminal blocks.



2. Connect the wires matching the terminal designations (+/-) of the controller terminals. Leave the drain wire loose.

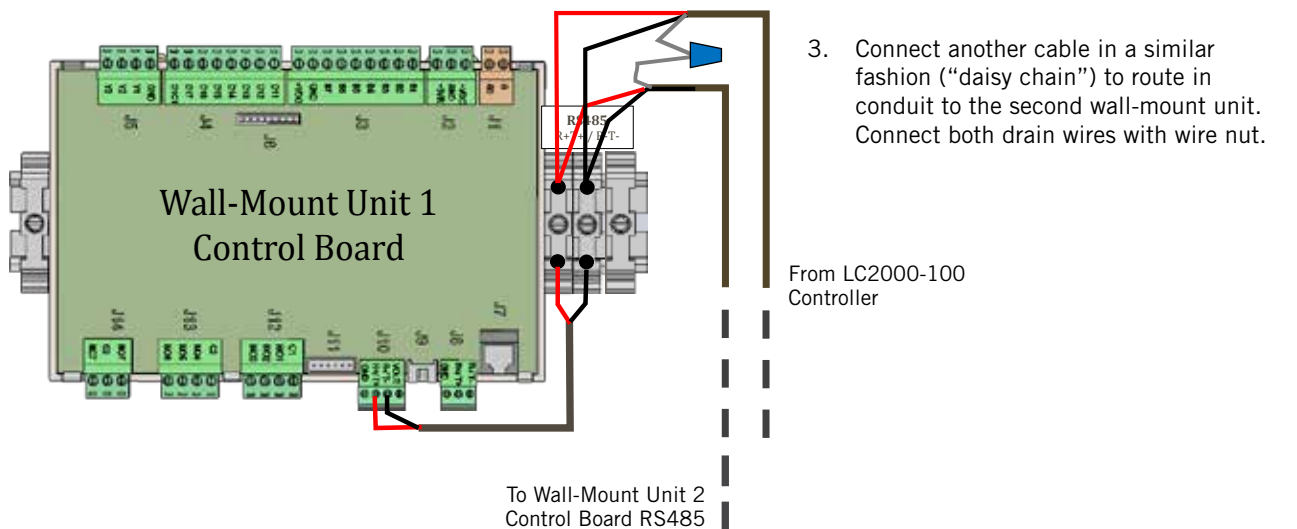

3. Connect another cable in a similar fashion (“daisy chain”) to route in conduit to the second wall-mount unit. Connect both drain wires with wire nut.

FIGURE 1.23
Communication Wiring: Termination at the Second Wall-Mount Unit

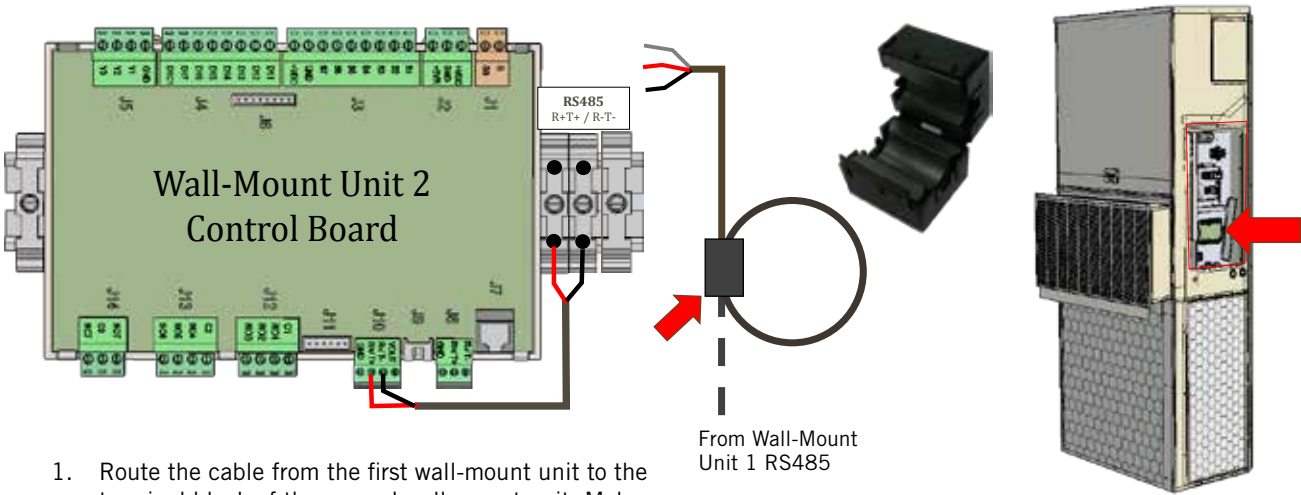

1. Route the cable from the first wall-mount unit to the terminal block of the second wall-mount unit. Make a small service loop and attach EMI filter as shown.

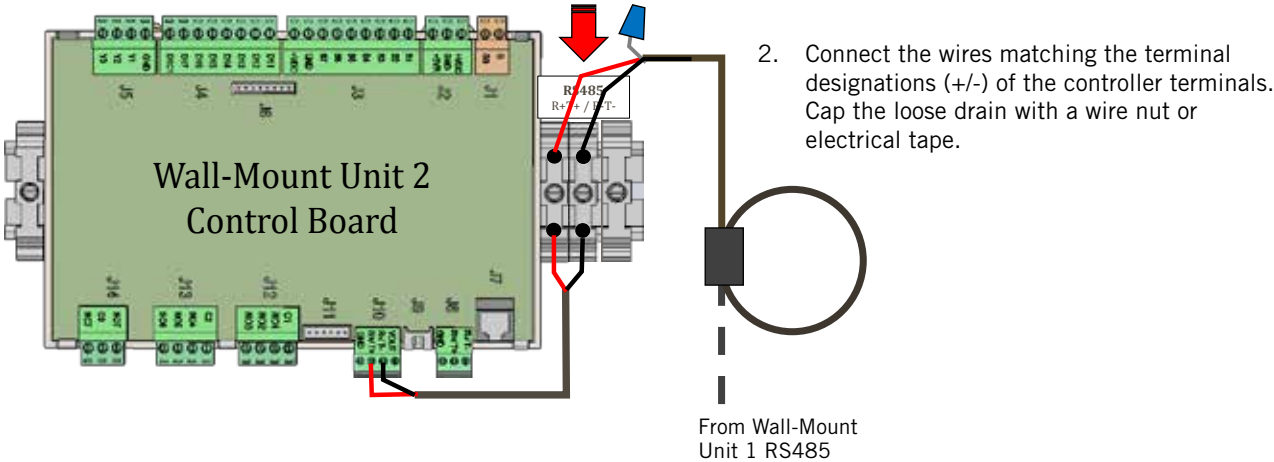

2. Connect the wires matching the terminal designations (+/-) of the controller terminals. Cap the loose drain with a wire nut or electrical tape.

6. Supply Wiring

The LC2000-100 controller is powered by -48VDC from the shelter. A field-supplied 5 amp DC circuit breaker is required. Field-supplied supply wiring should be minimum 16 guage, maximum 14 guage (see Figure 1.24). A reliable earth ground must be connected in addition to any grounding from conduit. Grounding posts are included with the controller for this purpose; install as shown in Figure 1.25. **Failing to ground the controller box properly could result in damage to the equipment.**

FIGURE 1.24
Bard-Link™ LC2000-100 Controller Supply Wiring

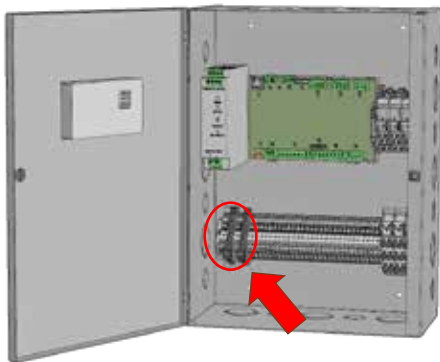

The Bard-Link™ controller requires a separate -48VDC power supply, an additional 5-amp DC breaker (field supplied) and minimum 16 gauge supply wire.

-48VDC termination at controller: Bring the -48VDC power supply wires through conduit to the controller box. Land the positive (+) 48VDC wire to terminal #1 and the negative (-) 48VDC wire to terminal #2.



NOTE: If the DC wiring is not terminated correctly on the specific polarity-indicated terminals of the PLC block, the PLC controller will not activate and will not function. Verify polarity of connections and wait to initialize controller until "startup procedures."

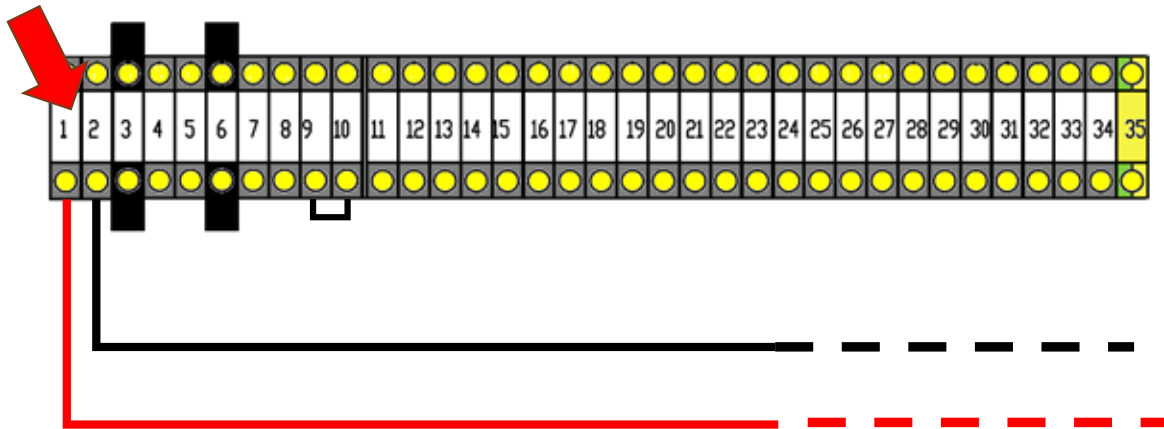
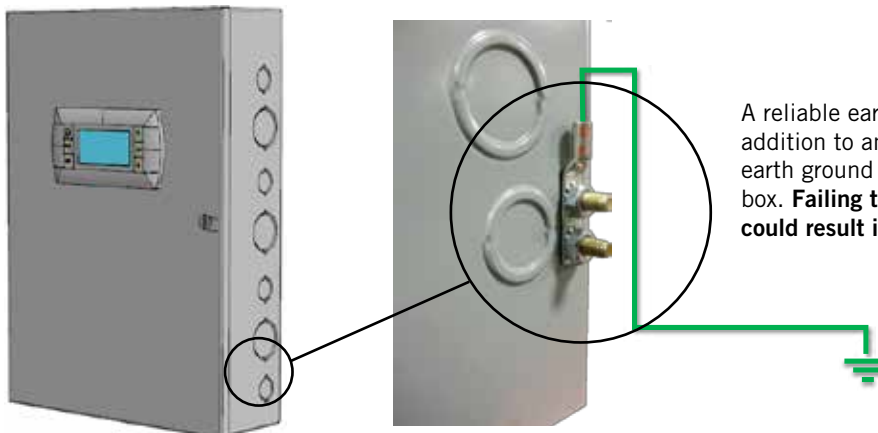

FIGURE 1.25
Controller Grounding Posts



A reliable earth ground must be connected in addition to any grounding from conduit. Attach earth ground to dedicated lugs on side of controller box. **Failing to ground the controller box properly could result in damage to the equipment.**

TABLE 1.2
Terminal Block Index

TB#	Wire Mark	Description	NO	NC
1	48+	48+ VDC Input		
2	48-	48- VDC Input		
3	24+	24+VDC Input – Hydrogen		
4	24-	24-VDC Input – Hydrogen		
5	HA2	HA2 – Hydrogen ALR Signal Return		
6	24+	24+ VDC Input – Smoke		
7	24-	24- VDC Input – Smoke		
8	SA2	SA2 – Smoke ALR Signal Return		
9	24-	24- VDC		
10	GA2	GA2 – Generator ALR Signal Return		
11	B1	Indoor Remote Sensor		
12	GND	GND		
13	B2	Spare Remote Sensor 1		
14	GND	GND		
15	B3	Spare Remote Sensor 2		
16	GND	GND		
17	S24	Smoke ALR Relay Contact		
18	S21	Smoke ALR Relay Contact Common		
19	H24	Hydrogen ALR Relay Contact		
20	H21	Hydrogen ALR Relay Contact Common		
21	G24	Generator ALR Relay Contact		
22	G21	Generator ALR Relay Contact Common		
23	NO1	Lag Unit Run Relay Contact		
24	C1	Lag Unit Run Relay Contact Common		
25	HT12	High Temp ALR Relay Contact		
26	HT11	High Temp ALR Relay Contact Common		
27	LT12	Low Temp ALR Relay Contact		
28	LT11	Low Temp ALR Relay Contact Common		
29	HF12	HVAC1 Fail ALR Relay Contact		
30	HF11	HVAC1 Fail ALR Relay Contact Common		
31	NO7	HVAC2 Fail ALR Relay Contact		
32	C3	HVAC2 Fail ALR Relay Contact Common		
33	R-	RS485 RX-/TX-		
34	R+	RS485 RX+/TX+		
35	GND	Drain Shield Grounding Wire		

FIGURE 1.26
LC2000 Wiring Diagram

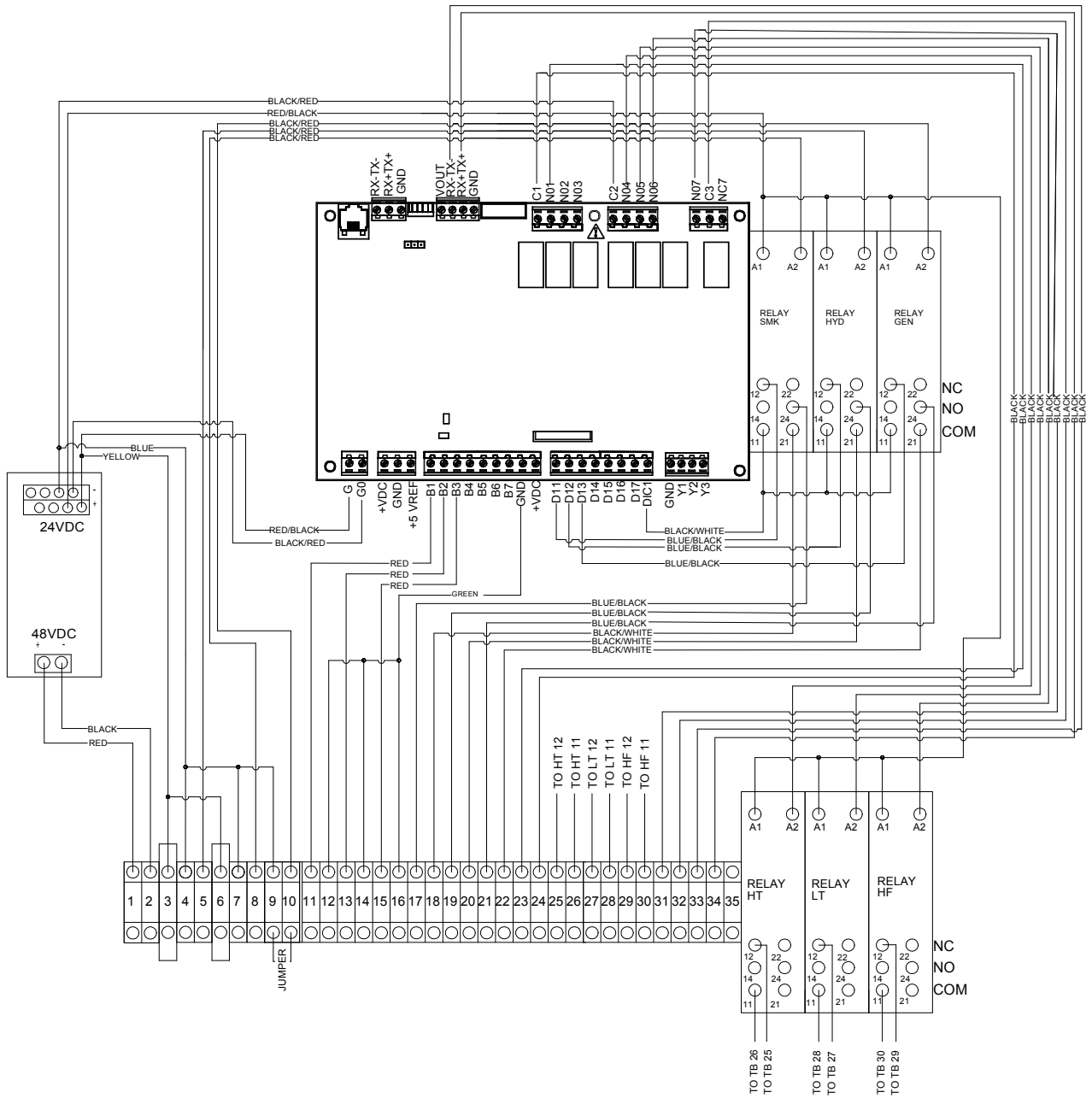

MIS-3632

SYSTEM START-UP

FIGURE 1.27
Bard-Link™ Controller Display



ALARM KEY

Allows viewing of active alarms
Silences audible alarms
Resets active alarms

MENU KEY

Allows entry to Main Menu

ESCAPE KEY

Returns to previous menu level
Cancels a changed entry

UP KEY

Steps to next screen in the display menu
Changes (increases) the value of a modifiable field

ENTER KEY

Accepts current value of a modifiable field
Advances cursor

DOWN KEY

Steps back to previous screen in the display menu
Changes (decreases) the value of a modifiable field

1. Set Controller Date and Time

- 1) Shut down all breakers to system, both wall-mount units and the Bard-Link™ controller.
- 2) Restore power (both AC and DC) to the two wall-mount units.
- 3) Turn on power to the Bard-Link™ controller. There is a forty (40) second delay prior to any function (other than display backlight) becoming active. The Status screen is the default screen when the controller has power.
- 4) Access the Main Menu by pressing the Menu key.
- 5) Press the UP or DOWN keys to scroll to the Clock/Scheduler menu. Press the ENTER key (see Figure 1.28).

- 6) Move the cursor to the Date line by pressing the ENTER key. Press the UP or DOWN keys to change the date. The Day line will automatically change when the date has been altered.
- 7) Press the ENTER key to move to the Hour line. Press the UP or DOWN keys to change the time. Press the ENTER key to set the time.
- 8) Press the ESCAPE several times to return to the Status menu.

2. Verify Communication to Units

Check controller display to see that both units are "ON-LINE" (see Figure 1.29). This typically takes 3-4 minutes after controller is powered.

FIGURE 1.28
Clock/Scheduler Menu

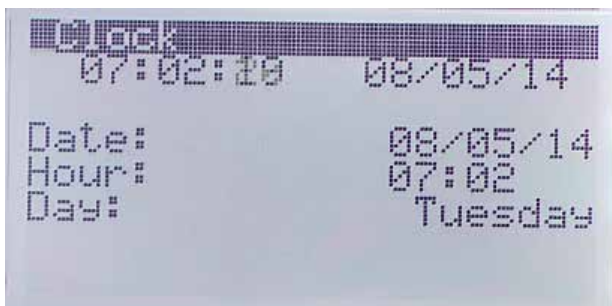
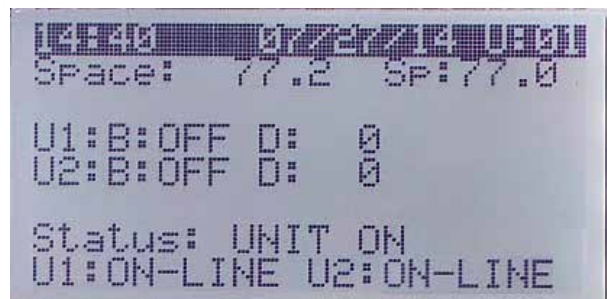

FIGURE 1.29
Status Display Showing Units "Online"



For shelter applications involving only a single DUAL-TEC™ DC Free Cooling Unit, see page 36.

3. Conduct Run Test

Execute a run test on each unit to verify the equipment is functioning correctly.

On Bard-Link™ controller, navigate to the Run Test screen (Figure 1.30).

FIGURE 1.30
Executing Run Test

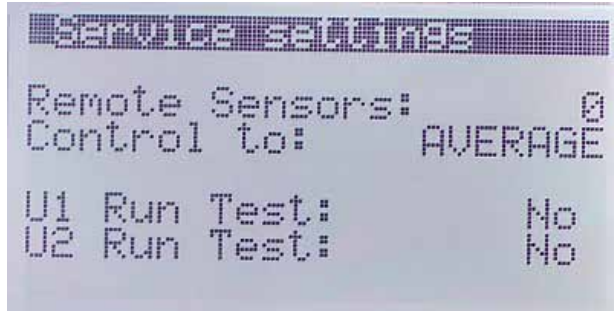

- 1) From the Main Menu screen, press the UP or DOWN key to get to Technician menu, hit ENTER key. (If not already on Main Menu screen, press MENU key to get to Main Menu.)
- 2) Use UP or DOWN key to get to Service menu, press ENTER key.

- 3) Use UP or DOWN key to get to Control menu, press ENTER key.
- 4) Cursor will be flashing in upper left corner of screen. Press ENTER key to scroll to U1 Run Test.

- 5) Press UP key to change 'No' on screen to 'Yes'. Unit 1 will begin the run test.

Note: While initiating the run test on each unit, use this opportunity to appropriately label each system as "Unit 1" or "Unit 2."

- 6) After the Unit 1 run test ends, press ENTER key to scroll to U2 Run Test.

- 7) Press UP key to change 'No' on screen to 'Yes'. Unit 2 will begin the run test.

Run Test Approximate Timings (in Minutes)

Blower	On: 0:00
Damper	Open: 0:00 – 2:40 Closed: 2:41 – 4:57
Compressor	On: 4:58 Off: 6:00
Heat	On: 6:01 Off: 7:10
Blower	Off: 8:19

4. Completing Installation

Once all the installation steps have been completed, and system verification and run test results were satisfactory, the installation can now be considered "complete". The Bard-Link™ PLC lead/lag controller has been pre-programmed with what is widely considered to be the most efficient operating parameters—see Table 1.3 on page 36. Further information on exact sequence of operation and advanced programming changes can be found in the Service section of this manual.

Cool Weather Operation (Free Cooling Available):

Stage 1 Cooling	78°F – Lead unit free-cooling damper opens (Setpoint + Cooling Stage 1 Differential)
Stage 2 Cooling	79°F – Lag unit free-cooling damper opens (+ Cooling Stage 2 Differential)
Stage 3 Cooling	81°F – Lead unit compressor, damper will stay open if conditions are conducive for free cooling (+ Cooling Stage 3 Differential)
Stage 4 Cooling	83°F – Lag unit compressor, damper will stay open if conditions are conducive for free cooling (+ Cooling Stage 4 Differential)
Hi-Temp Alarm #1	85°F
Hi-Temp Alarm #2	90°F – <u>Emergency ventilation initiates</u> , both dampers open, both blowers run 75°F – All cooling stops, blowers stop (Setpoint -2°F)
Stage 1 Heating	58°F – Lead unit heat strip activates
Stage 2 Heating	56°F – Lag unit heat strip activates
Low-Temp Alarm	45°F 62°F – All heating stops, blowers stop

Warm Weather Operation (No Free Cooling Available):

Stage 1 Cooling	78°F – Lead unit compressor (Setpoint + Cooling Stage 1 Differential)
Stage 2 Cooling	83°F – Lag unit compressor (+ Cooling Stage 2, Stage 3 and Stage 4 Differentials)
Hi-Temp Alarm #1	85°F
Hi-Temp Alarm #2	90°F – <u>Emergency ventilation initiates</u> , both dampers open, both blowers run 75°F – All cooling stops, blowers stop (Setpoint -2°F)

TABLE 1.3
Controller Default Settings

Description	Default Setpoint
Temperature at local remote (main) sensor	--
Temperature Setpoint	77°F
Heating Setpoint	60°F
Temperature High Limit – Level 1	85°F
Temperature High Limit – Level 2 (High Temp Alarm)	90°F
Temperature Low Limit	45°F
Cooling Stage 1 Differential	1°F
Cooling Stage 2 Differential	1°F
Cooling Stage 3 Differential	2°F
Cooling Stage 4 Differential	2°F
Heating Stage 1 Differential	2°F
Heating Stage 2 Differential	2°F
Minimum Compressor Run Time	5 Minutes
Minimum Compressor Off Time	2 Minutes
Comfort Mode Setpoint	72°F
Comfort Mode Operation Time	60 Minutes
DC Freecooling Setpoint	55°F
Lead/Lag Changeover Time (Rotation)	1
Temperature Units	°F

WEB CARD COMMUNICATION BOARD

Note: A web card communications board allows remote access, via Ethernet, to all functions of the controller system. This is the same as if one was in the building where the controller system is physically installed.

Connect the Bard-Link™ LC2000-100 controller Ethernet port to the existing Ethernet card in the shelter (if applicable) using CAT 6 Ethernet cable.

TEC-EYE HAND-HELD DIAGNOSTIC TOOL

The TEC-EYE hand-held diagnostic tool is included with each Bard-Link™ PLC lead/lag controller. Before leaving the jobsite, make sure to store the TEC-EYE hand-held diagnostic tool inside the shelter, preferably close to the Bard-Link™ PLC controller. The TEC-EYE has integrated magnets on the back of the tool, so it can even be attached to the front, sides, bottom or top of the PLC control box. Although the tool is not necessary for installation purposes, the “TEC-EYE” will be very valuable to technicians performing maintenance or repair procedures. Do not let the TEC-EYE leave the shelter.

SINGLE HVAC UNIT SHELTERS ONLY

In certain applications, only one wall-mount unit will be installed on a particular shelter. This may be desirable due to space considerations, load specifics or other non-typical situations. If only one Dual-Tec™ unit will be connected to the Bard-Link™ PLC controller, please follow the steps below to allow operation without nuisance alarms.

1. Go to the Setpoints menu on Bard-Link™ PLC controller; press ENTER key.
2. Press DOWN arrow key seven (7) times to reach "Number of Units" screen. Press ENTER key to cause cursor to flash.
3. Press DOWN arrow key to change value to "1".
4. Cycle power to Bard-Link™ PLC controller.

SPECIAL OPERATIONAL FORMAT: COASTAL MODE

In certain locations (geographical or situational), outdoor air used for “free cooling” can be corrosive or have other non-desirable qualities. Although the DC-FCU system was meant to take full advantage of outdoor air cooling, Bard Manufacturing has included a special operations format within the programming that will not allow any damper activity for “free cooling”. By enabling the “Coastal Mode” function, the DC-FCU system will only cool through mechanical (compressor) means. However, the damper will still open under emergency conditions (high temperature #2 alarm or hydrogen alarm, if installed) to flood the room with outdoor air, and the damper will allow for “free cooling” under a power loss situation when the compressor cannot function.

This mode is **set by the model and serial number**—completely automatic—and cannot be overridden locally.

SECTION 2:

SERVICE

INSTRUCTIONS

GENERAL REFRIGERANT INFORMATION

NOTICE

These units require R-410A refrigerant and polyol ester oil.

GENERAL

1. Use separate service equipment to avoid cross contamination of oil and refrigerants.
2. Use recovery equipment rated for R-410A refrigerant.
3. Use manifold gauges rated for R-410A (800 psi/250 psi low).
4. R-410A is a binary blend of HFC-32 and HFC-125.
5. R-410A is nearly azeotropic—similar to R-22 and R-12. Although nearly azeotropic, charge with liquid refrigerant.
6. R-410A operates at 40-70% higher pressure than R-22, and systems designed for R-22 cannot withstand this higher pressure.
7. R-410A has an ozone depletion potential of zero, but must be reclaimed due to its global warming potential.
8. R-410A compressors use polyol ester oil.
9. Polyol ester oil is hygroscopic; it will rapidly absorb moisture and strongly hold this moisture in the oil.
10. A liquid line dryer must be used—even a deep vacuum will not separate moisture from the oil.
11. Limit atmospheric exposure to 15 minutes.
12. If compressor removal is necessary, always plug compressor immediately after removal. Purge with small amount of nitrogen when inserting plugs.

TOPPING OFF SYSTEM CHARGE

If a leak has occurred in the system, Bard Manufacturing recommends reclaiming, evacuating (see criteria above) and charging to the nameplate charge. If done correctly, topping off the system charge can be done without problems.

With R-410A, there are no significant changes in the refrigerant composition during multiple leaks and recharges. R-410A refrigerant is close to being an azeotropic blend (it behaves like a pure compound or single component refrigerant). The remaining refrigerant charge in the system may be used after leaks have occurred. "Top-off" the charge by utilizing the pressure charts on the inner control panel cover as a guideline.

REMEMBER: When adding R-410A refrigerant, it must come out of the charging cylinder/tank as a liquid to avoid any fractionation and to insure optimal system performance. Refer to instructions for the cylinder that is being utilized for proper method of liquid extraction.

SAFETY PRACTICES

1. Never mix R-410A with other refrigerants.
2. Use gloves and safety glasses. Polyol ester oils can be irritating to the skin, and liquid refrigerant will freeze the skin.
3. Never use air and R-410A to leak check; the mixture may become flammable.
4. Do not inhale R-410A—the vapor attacks the nervous system, creating dizziness, loss of coordination and slurred speech. Cardiac irregularities, unconsciousness and ultimately death can result from breathing this concentration.
5. Do not burn R-410A. This decomposition produces hazardous vapors. Evacuate the area if exposed.
6. Use only cylinders rated DOT4BA/4BW 400.
7. Never fill cylinders over 80% of total capacity.
8. Store cylinders in a cool area, out of direct sunlight.
9. Never heat cylinders above 125°F.
10. Never trap liquid R-410A in manifold sets, gauge lines or cylinders. R-410A expands significantly at warmer temperatures. Once a cylinder or line is full of liquid, any further rise in temperature will cause it to burst.

R410-A REFRIGERANT CHARGE

This unit was charged at the factory with the quantity of refrigerant listed on the serial plate. AHRI capacity and efficiency ratings were determined by testing with this refrigerant charge quantity.

The pressure table found on the following page shows nominal pressures for the units. Since many installation specific situations can affect the pressure readings, this information should only be used by certified technicians as a guide for evaluating proper system performance. They shall not be used to adjust charge. If charge is in doubt, reclaim, evacuate and recharge the unit to the serial plate charge.

TABLE 2.1
Nominal Pressures

Model	Return Air Temperature	Pressure	Air Temperature Entering Outdoor Coil, Degree °F										Capacitors	
			75	80	85	90	95	100	105	110	115	120	Part No.	Ratings
			Low Side	High Side	Low Side	High Side	Low Side	High Side	Low Side	High Side	Low Side	High Side		
D28A	75° DB 62° WB	Low Side High Side	137 279	137 299	137 321	139 342	140 366	141 389	143 413	144 439	146 464	148 491	8552-055	1 Ø, 240V 40+10/370
	80° DB 67° WB	Low Side High Side	146 286	146 307	147 329	149 351	150 375	151 399	153 424	154 450	156 476	158 504		
	85° DB 72° WB	Low Side High Side	151 296	151 318	152 341	154 363	155 388	156 413	158 439	159 466	161 493	164 522		
D36A	75° DB 62° WB	Low Side High Side	133 313	135 327	137 342	138 361	139 382	141 406	143 432	145 461	147 492	149 527	8552-079	1 Ø, 240V 45+10/370
	80° DB 67° WB	Low Side High Side	142 321	144 335	146 351	148 370	149 392	151 416	153 443	155 473	157 505	159 540		
	85° DB 72° WB	Low Side High Side	147 332	149 347	151 363	153 383	154 406	156 431	158 459	160 490	162 523	165 559		
D42A	75° DB 62° WB	Low Side High Side	131 315	132 331	134 348	136 368	137 388	139 410	142 435	144 461	146 489	149 520	8552-079	1 Ø, 240V 45+10/370
	80° DB 67° WB	Low Side High Side	140 323	141 339	143 357	145 377	147 398	149 421	152 446	154 473	156 502	159 533		
	85° DB 72° WB	Low Side High Side	145 334	146 351	148 369	150 390	152 412	154 436	157 462	159 490	161 520	165 552		
D48A	75° DB 62° WB	Low Side High Side	133 325	136 341	137 360	139 379	141 401	142 424	144 449	145 477	147 505	148 535	8552-089	1 Ø, 240V 70+10/370
	80° DB 67° WB	Low Side High Side	142 333	145 350	147 369	149 389	151 411	152 435	154 461	155 489	157 518	158 549		
	85° DB 72° WB	Low Side High Side	147 345	150 362	152 382	154 403	156 425	157 450	159 477	160 506	162 536	164 568		
D60A	75° DB 62° WB	Low Side High Side	129 353	130 362	132 374	133 390	134 410	136 432	137 458	137 488	139 522	140 559	8552-058	1 Ø, 240V 80+10/440
	80° DB 67° WB	Low Side High Side	138 362	139 371	141 384	142 400	143 420	145 443	146 470	147 501	149 535	150 573		
	85° DB 72° WB	Low Side High Side	143 375	144 384	146 397	147 414	148 435	150 459	151 486	152 519	154 554	155 593		

Low Side Pressure ±4 PSIG
High Side Pressure ±10PSIG

FIGURE 2.1
Refrigerant Sight Glass

The refrigerant sight glass installed in this unit is not a charging indicator. The sight glass is for moisture reference only. If charge is in doubt, reclaim, evacuate and recharge the unit to the serial plate charge.



SEQUENCE OF OPERATION

D-SERIES WALL-MOUNT UNIT SEQUENCE OF OPERATION

Overview

This product is designed to function like a typical telecom air conditioning system with an outdoor air-cooling damper. However, the DC-FCU system does have some special features, like a PLC control which allows for advanced alarming and a “DC Free Cooling” feature that allows for forced emergency ventilated cooling anytime “shore power” VAC power from the utility company is lost. The internal controls within this unit automatically recognize a loss of shore power, energizing the indoor blower motor and powering the actuator to open the damper to bring in outdoor air. The power utilized during this time is the stored battery power from the equipment shelter.

Indoor Blower

The indoor blower is a 48VDC motor, completely separate from the VAC circuit(s). For the blower to activate, two separate actions must take place:

1. 24VDC from terminal N07 (Blower Motor Start Relay)
2. 0-10VDC signal from terminal Y1 (Speed Voltage)

While the 24VDC from N07 will always stay the same, the 0-10VDC signal from terminal Y1 will vary depending upon the mode. See Table 2.2.

DC Free Cooling Damper

This controller is enabled for dewpoint control, specifically examining the combination of temperature and relative humidity to determine the proper control of cooling. This calculated dewpoint property then determines the proper mode of cooling—Outdoor Air, Mechanical Cooling, or both. To signal the 24VDC damper actuator to open, a 2-10VDC signal must come from the Y2 terminal. Additionally, while other

modes get only a single speed from the indoor blower, free cooling mode will get two: one for outdoor air temperature above 40°F (faster), and another for those below 40°F (slower). See Table 2.2.

Cooling Call

When a call for cooling generates from the controller, the system will first determine which mode of cooling to employ based on the outdoor temperature, the outdoor humidity and the indoor temperature.

- If the outdoor temperature and humidity ratio are conducive to free cooling, the control board will send:
 1. 2-10VDC Signal from Y2 (Damper Signal)
 - Modulates damper to achieve 55°F at supply air temperature sensor
 2. 24VDC from terminal N07 (Blower Motor Start Relay)
 3. 0-10VDC signal from terminal Y1 (Speed Voltage)
- If the outdoor conditions are conducive to free cooling, but a 2nd stage cooling call is generated, the board will additionally add 24VAC signal from the N02 terminal to the CCM, activating the compressor. The damper will limit outdoor air to keep supply air temperature at 55°F.
- If conditions outside are not conducive to free cooling, the control board will send:
 1. 24VAC signal from N02 to CCM (Compressor)
 2. 24VDC from terminal N07 (Blower Motor Start Relay)
 3. 0-10VDC signal from Y1 (Speed Voltage)

TABLE 2.2
Blower Speed Voltage Chart

Model	Blower Only	Free Cooling Mode (CFM/VDC Speed Voltage)	Free Cooling Mode Below 40°F (CFM/VDC Speed Voltage)	Cooling (CFM/VDC Speed Voltage)	Electric Heat
D28A/D28L	Same as Free Cooling Mode	1800/7.0	800/2.8	1100/3.8	1800/7.0
D36A/D36L			800/2.8	1100/3.8	
D42A/D42L			950/3.1	1250/4.7	
D48A/D48L			1100/3.8	1600/6.3	
D60A/D60L			1100/3.8	1600/6.3	

Heating Call

When a call for heating generates from the controller, the control board will send:

1. 24VAC signal from terminal NO4 to heat strip contactor.
2. 24VDC from terminal N07 (Blower Motor Start Relay)
3. 0-10VDC signal from terminal Y1 (Motor Speed)

Loss of Utility Power

When AC power is lost to the unit (no shore power, no generator), the AC power loss relay will send a digital input to terminal DI 1, alerting the board. If the temperature outside is warmer than the shelter internal temperature, the units will remain static. If the temperature outside is cooler than the internal temperature and there is a generated cooling call, the control board will send:

1. 2-10VDC Signal from terminal Y2 (Damper Signal)
 - Modulates damper to achieve 55°F at supply air temperature sensor

2. 24VDC from terminal N07 (Blower Motor Start Relay)
3. 0-10VDC signal from terminal Y1 (Motor Speed)

Special Considerations

- Compressor Run Time – Once activated, the compressor will run for a minimum of 5 minutes, regardless of setpoint (PLC programming)
- Compressor Off Time – Once deactivated, the compressor will not start again for a minimum of 2 minutes.
- High Pressure Situation – The high pressure switch routes through the compressor control module (CCM), which allows one switch opening followed by a delay (soft lockout) of at least 2 minutes before trying again. If the switch is still open—or opens again on the same call—the CCM locks out the compressor and outdoor fan. Additionally, the CCM will send 24V to the high pressure alarm relay, which will then send a digital input to the DI 3 terminal.

FIGURE 2.2
Wall-Mount Unit Control Board

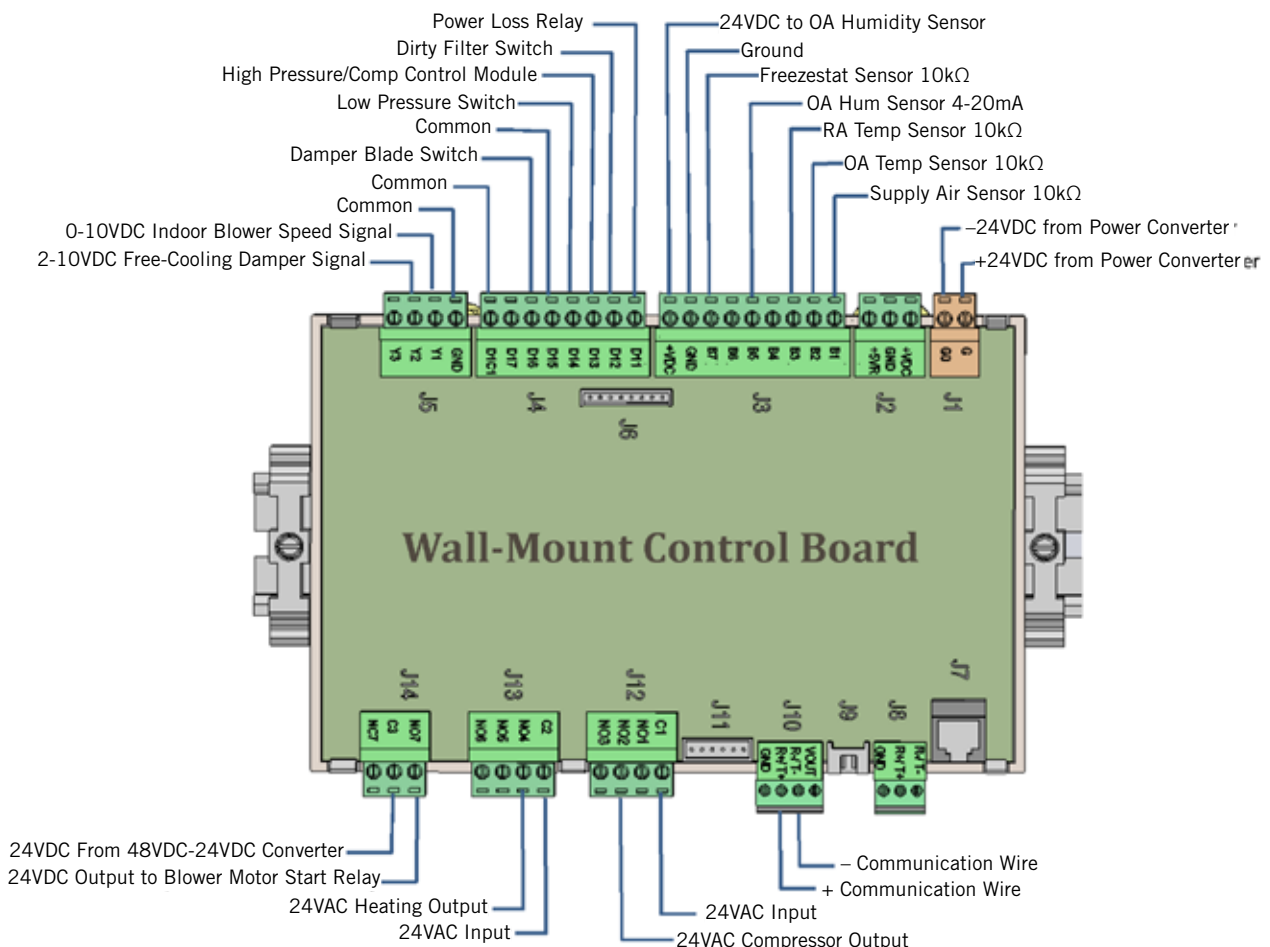

- Low Pressure Situation – The low pressure switch is routed directly to DI 4 on the board and has a very specific scheme of operation:
 1. If the switch opens, the board ignores the switch for 2 minutes (OAT above 50°F) or 3 minutes (OAT below 50°F).
 2. If the switch is still open after the delay, the board will stop compressor and outdoor fan function (soft lockout) for 2 minutes.
 3. If after 2 minutes, the low pressure switch is still open, or opens again immediately afterward, the board will delay for 2 minutes again (soft lockout).
 4. On the 3rd attempt, the board will lock out the compressor and outdoor fan until manually reset.
- High Temperature 2 Alarm – Should the shelter controller see 90°F, both free-cooling dampers will open (regardless of outdoor temperature) to cool the building.
- Smoke Alarm – Should the smoke detector send an alarm signal to the controller, all blower, compressor and ventilations functions cease.
- Hydrogen Alarm – Should the hydrogen detector send an alarm signal to the controller, both free cooling dampers will open (regardless of temperature) to dilute the shelter air.
- Freezestat – If coil temperature below 30°F is sensed by the freezestat, the compressor will deactivate for 5 minutes, or until the sensor sees 55°F, whichever comes first.
- Generator Run – During generator operation, the system may limit compressor operation to only one unit providing that a specific jumper was removed from the LC controller terminal block and the alarm wires were connected to a generator-run relay (please refer to the Installation section of this manual regarding alarms and wiring).

LC SERIES PLC CONTROLLER SEQUENCE OF OPERATION

Overview

The LC Series PLC controller is designed to operate two (2) Bard D-Series wall-mount units in a lead/lag fashion, while offering extensive alarming capabilities as well as remote communication. Inside the LC-2000 cabinet, there is a control board, a 48VDC to 24VDC converter/power source, six (6) isolation relays (to protect against errant voltages) and a terminal block. The duty of the PLC controller is to monitor temperature and alarm conditions within the shelter and to send cooling or heating orders to one, or both, wall-mount units. The controller also monitors the units and sends alarms.

Inputs/Outputs

The LC controller will make decisions and trigger alarms by the use of inputs and outputs to various field-installed connections to the terminal block. Please refer to the Installation section of this manual for further information on field-wire connections.

Power Inputs:

- -48VDC positive-ground power to terminals 1 (+) and 2 (-). This feeds the 48VDC to 24VDC power converter, which then powers the board and hydrogen and smoke detectors. **NOTE: Output must be minimum 22.8 VDC to allow proper PLC board operation.**

Power Outputs:

- 24VDC power to hydrogen detector through terminals 3 (+) and 4 (-). The + terminal block is fused internally (see Componentry section).
- 24VDC power to smoke detector through terminals 6 (+) and 7 (-). The + terminal block is fused internally (see Componentry section).
- -24VDC power to generator run relay contacts (if available) on terminal 9.

Detector Return Voltages:

- -24VDC signal from hydrogen detector on terminal 5 (always energizes hydrogen alarm isolation relay; de-energizes on alarm).
- -24VDC signal from smoke detector on terminal 8 (always energizes smoke alarm isolation relay; de-energizes on alarm).
- -24VDC signal from generator run contacts on terminal 10 (always energizes generator run alarm isolation relay; de-energizes on alarm).

Signal Inputs:

- 10K ohm remote indoor temperature sensor on terminals 11 and 12.
- 10K ohm optional remote indoor temperature sensor on terminals 13 and 14.
- 10K ohm optional remote indoor temperature sensor on terminals 15 and 16.

NC Contacts for External Alarm(s):

- Smoke alarm NC contacts on terminals 17 and 18.
- Hydrogen alarm NC contacts on terminals 19 and 20.
- Generator run alarm NC contacts on terminals 21 and 22.
- Lag unit run alarm NC contacts on terminals 23 and 24.
- High temp fail alarm NC contacts on terminals 25 and 26.
- Low temp fail alarm NC contacts on terminals 27 and 28.
- HVAC 1 contacts on terminals 29 and 30.
- HVAC 2 contacts on terminals 31 and 32.

Communication Output:

- Negative (-) communication wire to terminal 33.
- Positive (+) communication wire to terminal 34.
- Cable drain wire to terminal 35.

Isolation Relays and Alarm Schemes

Note that three of the factory-wired isolation relays (smoke, hydrogen and generator) will be always energized by their respective detectors—with all alarm signals sent through the NO contacts of the relays (which are closed as long as the relays are energized). The remaining three factory-wired isolation relays (low temp, high temp and HVAC 1 fail) relays are only energized during an alarm situation, and all alarm signals are sent through the NC contacts of the relays. These contacts open on alarm.

- Smoke: If smoke is detected in the shelter, the detector will open internal contact supplying -24VDC to terminal 8. This will de-energize the smoke isolation relay, which will send digital inputs to the board as well as open contacts 17 and 18. Board will then send remote alarms, and direct both wall-mount units to cease all operations until cleared.
- Hydrogen: If hydrogen is detected in the shelter, the detector will open internal contact supplying -24VDC to terminal 5. This will de-energize the hydrogen isolation relay, which will send digital

FIGURE 2.3
LC Series Controller Control Board and Terminal Block

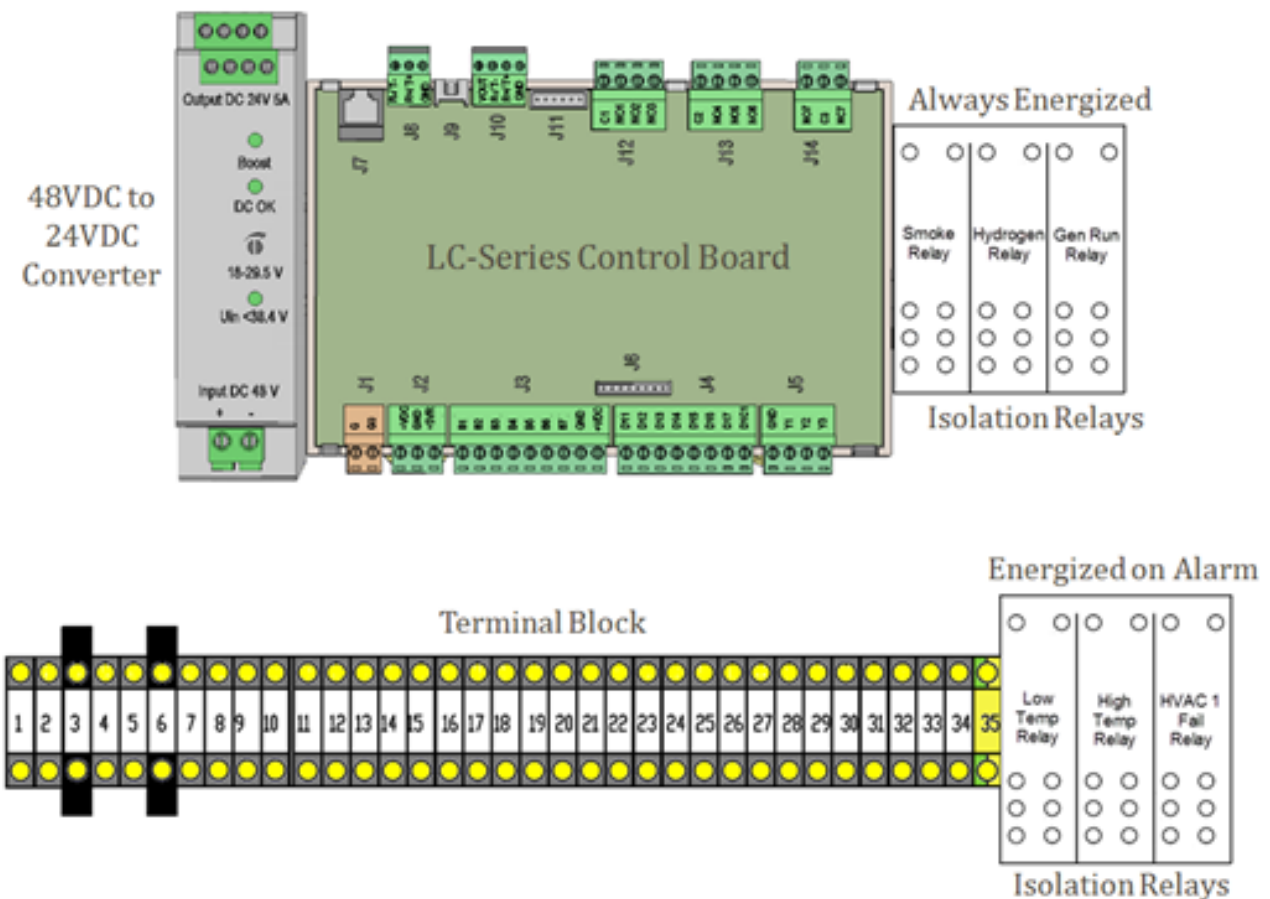

inputs to the board as well as open contacts 19 and 20. The LC board will then send remote alarms and direct both wall-mount units to activate free cooling dampers to dilute the shelter with outdoor air until cleared.

- Generator Run: If there is a generator onsite that is not large enough to power both wall-mount units in mechanical cooling, the installers were to pull a factory-installed jumper on terminals 9 and 10 and wire those terminals to the normally closed contacts of an existing or field-provided generator run relay. If this has been done, when the generator activates, the existing or field-provided generator run relay will open contacts and sever the -24VDC to terminal 10. This will de-energize the internal generator run relay, which will send digital inputs to the board as well as open contacts on terminals 21 and 22. The LC board will then send remote alarms and direct only the LEAD unit to operate until cleared. If the factory-mounted jumper has not been removed, generator operation will have no effect on the controller actions.

- Low Temp: If 45°F is sensed in the shelter, the LC board will send -24VAC to the low temp relay to energize the relay, opening contacts on terminals 27 and 28. Additionally, the board will send remote alarms.
- High Temp: If 90°F is sensed in the shelter, the LC board will send -24VAC to the high temp relay to energize the relay, opening contacts on terminals 25 and 26. Additionally, the LC will send remote alarms and enable blowers and free cooling dampers in an attempt to cool the shelter.
- HVAC 1 Fail: The HVAC 1 fail relay will be energized from the LC board through any of the following situations:
 - Unit 1 Loss of Power
 - Unit 1 Dirty Filter Switch
 - Unit 1 High/Low Pressure Switches
 - Unit 1 SAT/OAT/RAT/OAH Sensor Fail
 - Unit 1 Loss of Communication
 - Unit 1 Damper Fail to Open/Close

FIGURE 2.4
LC Series Controller Control Board

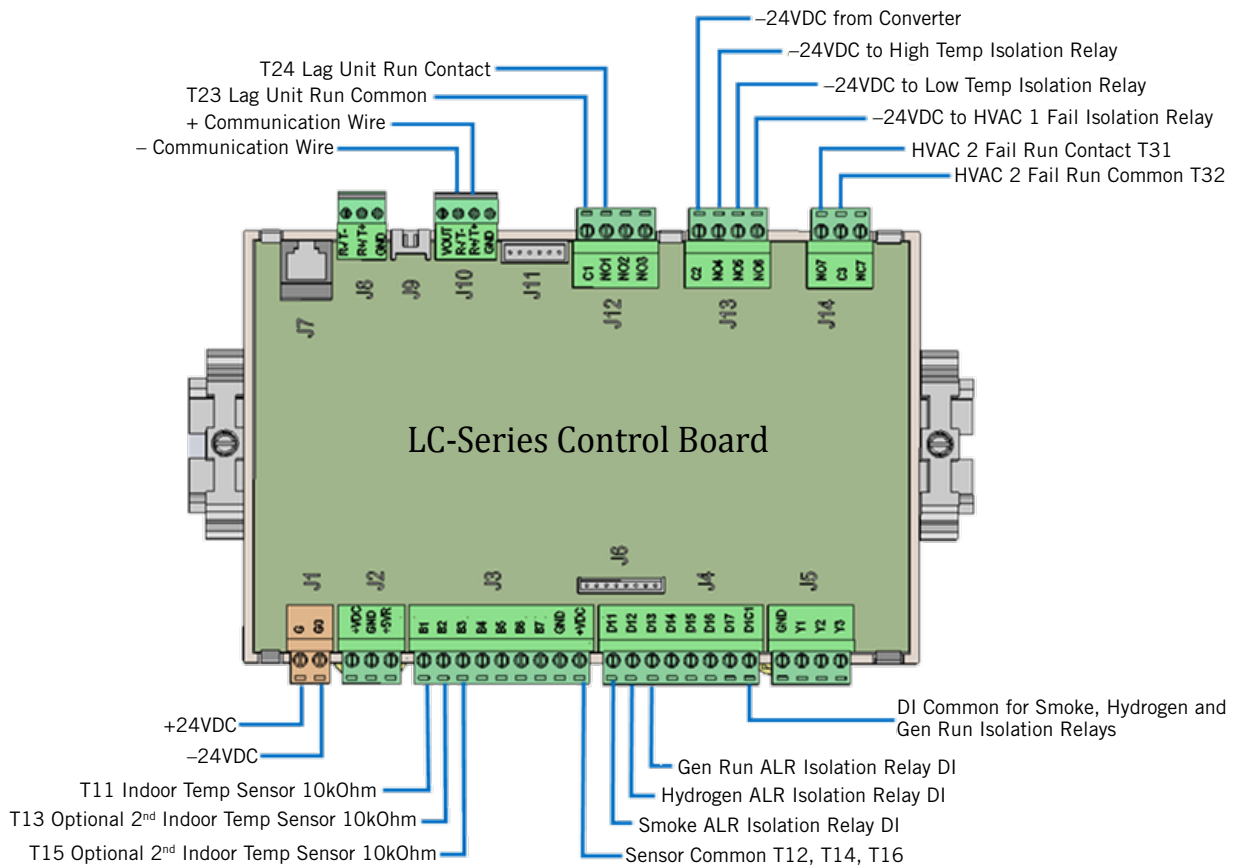

- Unit 1 Damper Fail to Close
- Unit 1 Filter Maintenance Alarm

Should Unit 1 encounter any of these issues, they will be communicated to the LC board which will energize the HVAC 1 fail relay with -24VDC, opening terminals 29 and 30. Additionally, the board will enable remote alarms.

Board Relays and Alarm Schemes

There are two alarms handled without the use of external isolation relays. They are board-initiated relays.

- HVAC 2 Fail: The HVAC 2 fail relay will be energized from the LC board through any of the following situations:
 - Unit 2 Loss of Power
 - Unit 2 Dirty Filter Switch

- Unit 2 High/Low Pressure Switches
- Unit 2 SAT/OAT/RAT/OAH Sensor Fail
- Unit 2 Loss of Communication
- Unit 2 Damper Fail to Open/Close
- Unit 2 Damper Fail to Close
- Unit 2 Filter Maintenance Alarm

Should Unit 2 encounter any of these issues, they will be communicated to the LC board, which will enable remote alarms and also open terminals 31 and 32.

- Lag Unit Run: Should temperature rise within the shelter require both compressors to run concurrently, the LC board will enable remote alarms and open terminals 23 and 24.

DC-FREE COOLING UNIT OPERATIONAL PARAMETERS

Overview

The Bard DC-Free Cooling Unit system is pre-programmed to provide the most efficient operating parameters based on indoor temperature, outdoor temperature, dewpoint and relative humidity. The following operational parameters are factory default.

Cool Weather Operation (Free Cooling Available):

Stage 1 Cooling	78°F – Lead unit free-cooling damper opens (Setpoint + Cooling Stage 1 Differential)
Stage 2 Cooling	79°F – Lag unit free-cooling damper opens (+ Cooling Stage 2 Differential)
Stage 3 Cooling	81°F – Lead unit compressor, damper will stay open if conditions are conducive for free cooling (+ Cooling Stage 3 Differential)
Stage 4 Cooling	83°F – Lag unit compressor, damper will stay open if conditions are conducive for free cooling (+ Cooling Stage 4 Differential)
Hi-Temp Alarm #1	85°F
Hi-Temp Alarm #2	90°F – <u>Emergency ventilation initiates</u> , both dampers open, both blowers run 75°F – All cooling stops, blowers stop (Setpoint -2°F)
Stage 1 Heating	58°F – Lead unit heat strip activates
Stage 2 Heating	56°F – Lag unit heat strip activates
Low-Temp Alarm	45°F 62°F – All heating stops, blowers stop

Warm Weather Operation (No Free Cooling Available):

Stage 1 Cooling	78°F – Lead unit compressor (Setpoint + Cooling Stage 1 Differential)
Stage 2 Cooling	83°F – Lag unit compressor (+ Cooling Stage 2, Stage 3 and Stage 4 Differentials)
Hi-Temp Alarm #1	85°F
Hi-Temp Alarm #2	90°F – <u>Emergency ventilation initiates</u> , both dampers open, both blowers run 75°F – All cooling stops, blowers stop (Setpoint -2°F)

FIGURE 2.5
Free Cooling Damper Operation

Free cooling can take place providing the outside air meets three separate criteria:

1. The dewpoint must be below 60°F
2. The relative humidity must be below 80%
3. The outside air must be cooler than the current setpoint.

With an accurate psychrometer, it is easy to pinpoint when the damper should be open or closed during normal operations.

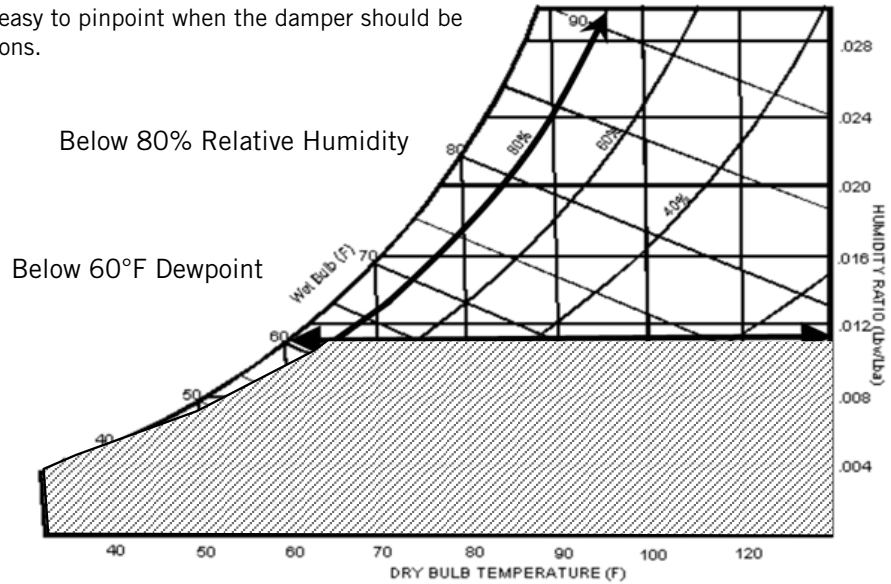

TABLE 2.3
Controller Default Settings

Description	Default Setpoint	Description	Default Setpoint
Temperature at local remote (main) sensor	--	Heating Stage 1 Differential	2°F
Temperature Setpoint	77°F	Heating Stage 2 Differential	2°F
Heating Setpoint	60°F	Minimum Compressor Run Time	5 Minutes
Temperature High Limit – Level 1	85°F	Minimum Compressor Off Time	2 Minutes
Temperature High Limit – Level 2 (High Temp Alarm)	90°F	Comfort Mode Setpoint	72°F
Temperature Low Limit	45°F	Comfort Mode Operation Time	60 Minutes
Cooling Stage 1 Differential	1°F	DC Freecooling Setpoint	55°F
Cooling Stage 2 Differential	1°F	Lead/Lag Changeover Time (Rotation)	1
Cooling Stage 3 Differential	2°F	Temperature Units	°F
Cooling Stage 4 Differential	2°F		

ADVANCED PROGRAMMING

FIGURE 2.6
Bard-Link™ Controller Display



ALARM KEY

Allows viewing of active alarms
Silences audible alarms
Resets active alarms

MENU KEY

Allows entry to Main Menu

ESCAPE KEY

Returns to previous menu level
Cancels a changed entry

UP KEY

Steps to next screen in the display menu
Changes (increases) the value of a modifiable field

ENTER KEY

Accepts current value of a modifiable field
Advances cursor

DOWN KEY

Steps back to previous screen in the display menu
Changes (decreases) the value of a modifiable field

BARD LINK™ CONTROLLER USER INTERFACE

The microprocessor control used in these wall mount air conditioners allows for complete control and monitoring through the use of the Bard Link™ LC2000-100 controller. This controller utilizes the latest in state-of-the-art technology including a large, easy-to-read backlit LCD graphic display.

The menu driven interface provides users the ability to scroll through three menu levels: Info, Control and Service. The menus permit the user to easily view, control and configure the unit.

The controller is completely programmed at the factory; therefore, most applications will require no field set-up. However, the default setpoints and their ranges are easily viewed and adjusted from the controller display. The program and operating parameters are permanently stored on FLASH-MEMORY in case of power failure. The controller is designed to manage temperature levels to a user-defined setpoint via control output signals to the wall-mount air conditioning system.

WEB CARD COMMUNICATION BOARD

A web card communications board allows remote access, via Ethernet, to all functions of the controller system. This is the same as if one was in the building where the controller system is physically installed.

CONTROLLER POWER-UP

Whenever power is first applied to the controller, there is a forty (40) second time delay prior to any function (other than display) becoming active.

CONTROLLER INTERFACE ACRONYMS

SAT – Supply air temperature
RAT – Return air temperature
OAT – Outdoor air temperature
OAH – Outdoor air humidity
Dew – Dewpoint temperature
Sp – Temperature setpoint
Space – Space temperature
U1 – Unit 1
U2 – Unit 2
F – Indoor blower status
D – DC free cooling damper position status
EM – Emergency ventilation mode
C1 – Compressor activate status/
Compressor stage 1 activate status
HT – Heater status
OA Dew Point – Calculated outdoor dew point
FC – DC free cooling status
RN – Component run time in minutes in last hour
ST – Number of start requests in last hour
Dp – DC free cooling damper

CONTROLLER INTERFACE MENU STRUCTURE

- On/Off Unit
- Setpoint
- Clock/Scheduler
- Input/Output
 - Analog Inputs
 - Digital Inputs
 - Relay Outputs
 - Analog Outputs
- Alarm History
- Technician
 - Information
 - BMS Configuration
 - Service Settings
 - Control Loops
 - Probe Adjustment
 - Manual Management
 - Analog Inputs
 - Digital Inputs
 - Relay Outputs
 - Analog Outputs
- Factory
 - Configuration
 - I/O Configuration
 - Factory Settings
 - Initialization

In addition to the menu structure above, there are also Status and Alarm screens.

Press the MENU key from any screen to return to the Main Menu. Press the UP or DOWN keys to scroll through the available menus. When the desired menu is highlighted, press the ENTER key to access that menu. Press the ESCAPE key or MENU key to return to the STATUS screen from the Main Menu.

NOTE: Normal operating setpoints have been locked and cannot be changed permanently, except by remote access. Any changes made to normal operational setpoints will be held for only 60 minutes. The following programming for typical application items can be accessed/changed locally and will not revert back after 60 minutes.

Comfort Mode

1. Press and release the ENTER key for comfort mode to change the Cooling Setpoint to 72°F for a period of 1 hour.
2. Setpoints will return to the programmed settings automatically after 1 hour.
3. The status screen will display COMFORT MODE while in override mode.
4. Pressing the ENTER key during the 1-hour period will deactivate COMFORT MODE.

Status Screen

The STATUS screen is the default start-up screen and also the return screen after 5 minutes of no activity. The screen can be accessed any time by pressing the ESCAPE button repeatedly.

The main screen of the STATUS screen displays the current date, time, space temperature and temperature setpoint. The same screen will also show the current system operating status for Unit 1 (U1) and Unit 2 (U2).

The screen will display "B" for blower with "ON" or "OFF" and "D" for damper followed by the percentage that the damper is open. If the compressor is running, it will be noted by "C1".

Using the UP/DOWN arrow keys, the user can scroll through a host of other information:

- SAT/RAT/OAT/OAH and dewpoints at either unit
- Last hour averages information
- Last hour tracking information

FIGURE 2.7
Controller Status Display

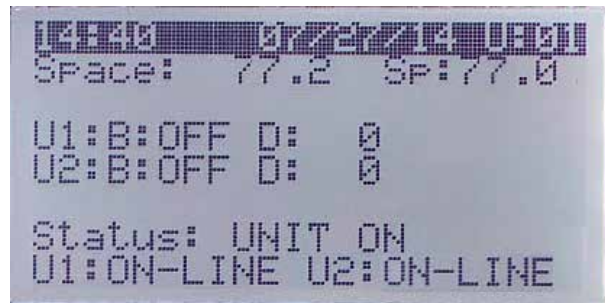

For the following items, press the MENU key to access programming.

Run Test

Execute a run test on each unit to verify the equipment is functioning correctly.

1. Go to Technician menu, press ENTER key.
2. Press UP or DOWN arrow keys to get to Service Settings menu, press ENTER key.
3. Press UP or DOWN arrow keys to get to Control Loops menu, press ENTER key.
4. Cursor will be flashing in upper left corner of screen. Press ENTER key to scroll to U1 Run Test.
5. Press UP key to change 'No' on screen to "Yes". Unit 1 will begin the run test.
6. After the Unit 1 run test ends, press ENTER key to scroll to U2 Run Test.
7. Press UP key to change 'No' on screen to "Yes". Unit 2 will begin the run test.

Run Test Approximate Timings (in Minutes)

Blower	On: 0:00
Damper	Open: 0:00 – 2:40
	Closed: 2:41 – 4:57
Compressor	On: 4:58
	Off: 6:00
Heat	On: 6:01
	Off: 7:10
Blower	Off: 8:19

Adjusting Date and Time

1. Go to Clock/Scheduler menu, press ENTER key.
2. Move the cursor to the selected choice by pressing the ENTER key.
3. Press UP or DOWN arrow keys to change the date and/or time. The day will automatically change when the date has been altered.

Setting Continuous Blower

1. Go to Setpoint menu, press ENTER key.
2. Go to Blower Settings screen, move the cursor to the selected choice by pressing the ENTER key.
3. Press UP or DOWN arrow keys to change the desired value:
Lead: Lead unit blower only
Both: Both units continuous

Advancing Lead/Lag Positions

1. Go to Clock/Scheduler menu, press ENTER key.
2. Go to Unit Rotation screen.
3. To switch lead unit: Move the cursor to the selected choice by pressing the ENTER key. Press UP or DOWN arrow keys to change the desired value. Unit rotation will change from 1 to 2 or 2 to 1.

Changing to Celsius

1. Go to Factory menu, press ENTER key.
2. Go to Configuration menu. Move the cursor to Temperature Unit by pressing the ENTER key. Press UP or DOWN arrow keys to change to °C. This will be a global change within the units on the structure; the temperature value will be displayed in °C for all locations within the display.

Calibrating Sensors

1. Go to Technician menu, press ENTER key.
2. Go to Service Settings menu, press ENTER key.
3. Go to Probe Adjustment, press ENTER key.
4. Move the cursor to enter the offset to the temperature value.

Example: The sensor reading displays on the screen as 80°F and the actual measured value using a calibrated sensor is 77°F. Enter an offset

of -3.0°F to display the temperature correctly. An offset of -9.9°F to +9.9°F can be entered.

Resetting Controller Model/Serial Numbers

1. Go to Factory menu, press ENTER key.
2. Go to Factory Settings screen, press ENTER key.
3. Press the ENTER key to move the cursor to the Serial Number selection. Press and hold UP or DOWN arrow keys to get to the desired value and then press ENTER key. Repeat for the rest of the digits/characters: Press and hold UP or DOWN arrow keys to get to the desired value and then press ENTER key to key in next digits/characters.
4. Model number is entered by the factory. In the case it is accidentally changed, the field technicians will need to enter the model number. Follow Step 3 above to enter the model number in the same fashion that the serial number was entered.

Configuring Additional Remote Indoor Temperature Sensors

Follow the steps below to configure additional remote indoor temperature sensors. The default remote sensor supplied by Bard is identified as B01, the first additional sensor added is B02 and the second additional sensor is B03 (see page 23 for directions on connecting the additional remote sensors to terminals 13 and 14 (B02) and 15 and 16 (B03)).

1. Go to Technician menu, press ENTER key.
2. Go to Service Settings menu, press ENTER key.
3. Go to Control Settings, press ENTER key.
4. Use the ENTER key to select Remote Sensors. The number displayed is the quantity of additional remote indoor temperature sensors installed. The default setting is 0 meaning only the remote sensor supplied by Bard with the controller is installed.
5. Press the UP or DOWN arrow keys to enter quantity of additional remote sensors installed—1 or 2.
6. Move the cursor to Control using the ENTER key to pick AVERAGE (default) or HIGHEST for the sensors to control and maintain space temperature.

Disabling One Unit/Control and Making the Controller Work with Only One Unit

1. Go to Setpoint menu, press ENTER key.
2. Press UP or DOWN arrow keys to go to the screen where it displays Number of Units and press ENTER key.
3. Change the value of Number of Units by pressing the DOWN arrow once to change to One (1), then press ENTER key.

An outdoor unit may now be powered down for an indefinite period of time for repairs or maintenance. The controller will operate on one system only.

Acknowledging/Clearing Alarms

Alarm conditions activate a red LED indicator that backlights the ALARM function key. As an option, an alarm condition may also be enunciated by an audible alarm signal. An alarm is acknowledged by pressing the ALARM key. This calls up alarm display screen(s) that provide a text message detailing the alarm condition(s). After an alarm condition is corrected, the alarm can be cleared by pressing the ALARM key.

Simulating Alarms (Smoke, Hydrogen, Generator Alarms)

NOTE: Many smoke and hydrogen detectors have manual test buttons on the face of the devices which may be easier to manipulate.

1. Go to Technician menu, press ENTER key.
2. Go to Manual Management, press ENTER key.
3. Go to Digital Inputs, press ENTER key.
4. Press the ENTER key to move the cursor to Smoke Manual DI 1 and press ENTER key.
5. Press UP or DOWN arrow keys to change the value from "Open" to "Closed"; alarm activates.
6. Reverse procedure to terminate test.
7. Repeat steps for hydrogen and generator using programming lines Hydrogen DI and Generator Run DI 3.

Simulating Alarms (High/Low Temp, HVAC 1/2 Fail, Lag Alarms)

1. Go to Technician menu, press ENTER key.
2. Go to Manual Management, press ENTER key.
3. Go to Relay Outputs, press ENTER key.
4. Press the ENTER key to move the cursor to High Temp Relay 4 and press ENTER key.
5. Press UP or DOWN arrow keys to change the value from "On" to "Off"; alarm activates.
6. Reverse procedure to terminate test.
7. Repeat steps using programming lines for low temp, HVAC fail and lag unit alarms.

Changing NC Contacts to NO Contacts

For lag unit on, high temp alarm, low temp alarm, HVAC 1 fail alarm and HVAC 2 fail alarm:

1. Go to Factory menu, press ENTER key.
2. Go to I/O Configuration, press ENTER key.
3. Go to Relay Outputs, press ENTER key.
4. Press UP or DOWN arrow keys to scroll to the desired relay output.
5. Press the ENTER key to move the cursor to Direction; press the UP arrow to change the contact direction to NO (from default NC). Verify the status of this relay contact change to Off.
6. When cursor is flashing at top left, press UP or DOWN arrow keys to make changes to other relay outputs if required.

TABLE 2.4
Controller Programmable Features and Default Settings

Description	Range	Default Setpoint	Units
Temperature at local remote (main) sensor	--	--	--
Temperature Setpoint*	65 - 90	77	°F
Heating Setpoint*	52 - 75	60	°F
Temperature High Limit - Level 1*	70 - 120	85	°F
Temperature High Limit - Level 2*	70 - 120	90	°F
Temperature Low Limit	28 - 65	45	°F
Cooling Stage Differential*	1 - 5	5	°F
Heating Stage Differential*	1 - 5	2	°F
Comfort Mode Setpoint*	65 - 80	72	°F
Comfort Mode Operation Time*	30 - 90	60	Minutes
DC Freecooling Setpoint	--	55	°F
Lead-Lag Changeover Time (Rotation)	1 - 30 days, or 0 for disabled	1	Day(s)
Temperature Units	°F/°C	°F	--

* Normal operating setpoints have been locked and cannot be changed permanently, except by remote access. Any changes made to normal operational setpoints will be held for only 60 minutes.

CAUTION

The Bard DC-FCU System has been pre-programmed with what is widely considered to be the best settings for efficiency and operation. Any changes to internal programming through the LC-Series Controller or the TEC-EYE not covered within this manual may cause the systems to operate improperly, cause internal damage to the HVAC units, cause the shelter to overheat or other very serious consequences. Although complete controller programming architecture for both the LC-Controller and TEC-EYE has been provided, going outside the boundaries of what has been covered in this manual is not recommended.

USING THE TEC-EYE

FIGURE 2.8
TEC-EYE Display



ALARM KEY

Allows viewing of active alarms
Silences audible alarms
Resets active alarms

MENU KEY

Allows entry to Main Menu

ESCAPE KEY

Returns to previous menu level
Cancels a changed entry

UP KEY

Steps to next screen in the display menu
Changes (increases) the value of a modifiable field

ENTER KEY

Accepts current value of a modifiable field
Advances cursor

DOWN KEY

Steps back to previous screen in the display menu
Changes (decreases) the value of a modifiable field

TEC-EYE HAND-HELD DIAGNOSTIC TOOL

The microprocessor control used in this wall mount air conditioning system allows for complete control and monitoring through the use of the provided TEC-EYE hand-held monitor. This comprehensive service tool utilizes the latest in state-of-the-art technology including a large, easy-to-read backlit LCD graphic display.

The menu driven interface provides users the ability to scroll through three menu levels: Info, Control and Service. The menus permit the user to easily view, control and configure the unit.

The controller is completely programmed at the factory; therefore, most applications will require no field set-up. However, the default setpoints and their ranges are easily viewed and adjusted from the TEC-EYE display. The program and operating parameters are permanently stored on FLASH-MEMORY in case of power failure. The controller is designed to manage temperature levels to a user-defined setpoint via control output signals to the wall mount air conditioning system.

The TEC-EYE connects to the wall-mount unit control board via an RJ11 modular phone connector as shown in Figure 2.9.

The TEC-EYE hand-held diagnostic tool should be stored somewhere inside the shelter, preferably close to the Bard-Link™ PLC controller. The TEC-EYE has integrated magnets on the back of the tool, so it can be attached to the front, sides, bottom or top of the PLC control box.

FIGURE 2.9
TEC-EYE Connection to Unit Control

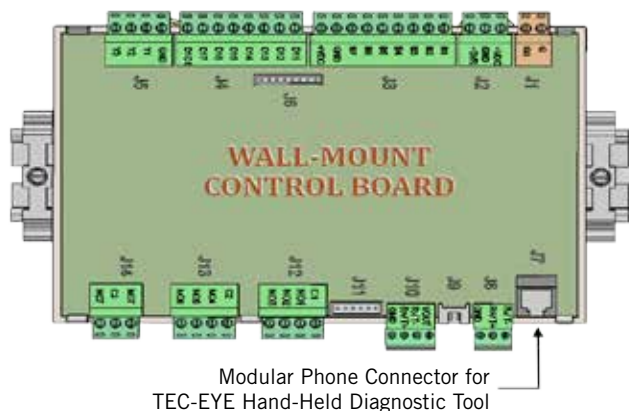

TEC-EYE Menu Structure

- On/Off Unit
- Setpoint
- Clock/Scheduler
- Input/Output
 - Analog Inputs
 - Digital Inputs
 - Relay Outputs
 - Analog Outputs
- Alarm History
- Technician
 - Information
 - Working Hours
 - Service Settings
 - Control Loops
 - Probe Adjustment
 - Manual Management
 - Analog Inputs
 - Digital Inputs
 - Relay Outputs
 - Analog Outputs
- Factory
 - Configuration
 - I/O Configuration
 - Factory Settings

In addition to the menu structure above, there are also Status and Alarm screens.

TEC-EYE Acronyms

- SAT – Supply air temperature
- RAT – Return air temperature
- OAT – Outdoor air temperature
- OAH – Outdoor air humidity
- Sp – Temperature setpoint
- Space – Space temperature
- U1 – Unit 1
- U2 – Unit 2
- F – Indoor blower status
- D – DC free cooling damper position status
- EM – Emergency ventilation mode
- C1 – Compressor activate status
- HT – Heater status
- OA Dew Point – Calculated outdoor dew point
- FC – DC free cooling status
- RN – Component run time in minutes in last hour
- ST – Number of start requests in last hour

Press the MENU key to access the Main Menu screen. Press the UP or DOWN keys to scroll through the available menus. When the desired menu is highlighted, press the ENTER key to access that menu. Press the ESCAPE key or MENU key to return to the STATUS screen from the Main Menu.

NOTE: Normal operating setpoints have been locked and cannot be changed permanently, except by remote access. Any changes made to normal operational setpoints will be held for only 60 minutes. The following programming for typical application items can be accessed/changed locally and will not revert back after 60 minutes.

Status Screen

The STATUS screen is the default start-up screen and also the return screen after 5 minutes of no activity. The screen can be accessed any time by pressing the ESCAPE button repeatedly.

The STATUS screen displays the current date, time, return air temperature, supply air temperature, outdoor air temperature, outdoor humidity and dewpoint conditions. It also indicates the current system operating status for Unit 1 (U1) or Unit 2 (U2). The screen displays whether the blower is off or on and what percentage the damper is open.

FIGURE 2.10
TEC-EYE Status Display



For the following items, press the MENU key to access programming.

Executing a Run Test

Execute a run test on each unit to verify the equipment is functioning correctly.

1. Go to Technician menu, press ENTER key.
2. Press UP or DOWN arrow keys to get to Service Settings menu, press ENTER key.
3. Press UP or DOWN arrow keys to get to Control Loops menu, press ENTER key.
4. Cursor will be flashing in upper left corner of screen. Press DOWN arrow key to scroll through screens to Run Test.
5. Press ENTER key to scroll to Enable. Press UP or DOWN arrow keys to change No to Yes. Unit will begin the run test.

Run Test Approximate Timings (in Minutes)

Blower	On: 0:00
Damper	Open: 0:00 – 2:40 Closed: 2:41 – 4:57
Compressor	On: 4:58 Off: 6:00
Heat	On: 6:01 Off: 7:10
Blower	Off: 8:19

Identifying a Unit Address

1. Go to On/Off Unit menu.
2. Screen will display individual address of wall-mount unit.

Manual Override Outputs

Blower

1. Go to Technician menu, press ENTER key.
2. Go to Manual Management, press ENTER key.
3. Go to Relay Outputs, press the DOWN arrow to get to Blower Relay Output. Move the cursor to the selected choice by pressing the ENTER key. Press UP or DOWN arrow keys to change the Manual Relay and Manual Position to "ON."
4. Press ESCAPE key, go to Analog Outputs.
5. Go to Blower Motor Analog Output, press Enter key to move the cursor to Mode. Change to Hand by pressing the UP arrow key. Press ENTER key. Next change the Manual Value to test blower speed voltage for the unit model and press ENTER key. Refer to the unit blower speed voltages provided in Table 2.8 on page 64; do not exceed the maximum speed voltage (VDC) for the unit model.

DC Free Cooling Damper

1. Go to Technician menu, press ENTER key.
2. Go to Manual Management, press ENTER key.
3. Go to Analog Outputs, press ENTER key.
4. Press DOWN arrow key to scroll screens to Analog Output 2 Damper.
5. Press ENTER key to scroll to Mode line. Press DOWN key to change Auto to Hand.
6. Press ENTER key to scroll to Manual Value line; Press UP or DOWN arrow keys to change the manual value to a desired value (maximum is 10VDC) to perform damper test.
7. Verify damper operation.

Compressor

1. Go to Technician menu, press ENTER key.
2. Go to Manual Management, press ENTER key.
3. Go to Relay Output, press ENTER key.
4. Go to Relay Output Cooling Stage. Press UP or DOWN arrow keys to change Manual Relay to "ON"; press ENTER key. Press UP or DOWN arrow keys to change manual position to "ON" and press ENTER key.
5. Verify compressor is running.

Heat

1. Go to Technician menu, press ENTER key.
2. Go to Manual Management, press ENTER key.
3. Go to Relay Output, press ENTER key.
4. Go to Relay Output Heating, press ENTER key.
5. Press UP or DOWN arrow keys to change Manual Relay and Manual Position to "ON" and press ENTER key.
6. Verify heater "ON" status.

CAUTION

The Bard DC-FCU System has been pre-programmed with what is widely considered to be the best settings for efficiency and operation. Any changes to internal programming through the LC-Series Controller or the TEC-EYE not covered within this manual may cause the systems to operate improperly, cause internal damage to the HVAC units, cause the shelter to overheat or other very serious consequences. Although complete controller programming architecture for both the LC-Controller and TEC-EYE has been provided, going outside the boundaries of what has been covered in this manual is not recommended.

COMPONENTRY SPECIFICATIONS

WARNING

Electrical shock hazard.

Disconnect both VAC and VDC power supplies before servicing.

Failure to do so could result in electric shock or death.

LOW PRESSURE SWITCH

Cut-out pressure: 40psi (+/- 4 psi)

Cut-in pressure: 55psi (+/- 4psi)

HIGH PRESSURE SWITCH

Cut-out pressure: 650psi (+/- 10 psi)

Cut-in pressure: 520psi (+/- 15psi)

LOW AMBIENT CONTROL

Modulating head-pressure control that allows full speed at pressures above 315psi. Below 315psi, the control will slow fan speed—following internal head pressures—until a minimum RPM is reached (approx 300 RPM). Below this point, the control will shut the fan completely off until internal pressures rise. The control is preset from the factory, but should adjustment become necessary, there is an adjustment screw located on the bottom of the control behind a weatherproof cap. One full turn clockwise equals approximately +48 psi.

REMOTE INDOOR TEMPERATURE SENSOR

White, decorative plastic casing, Bard logo, field-installed in shelter: 10k ohm resistance, see Table 2.5 on page 56.

DISCHARGE TEMP SENSOR

4.75" stainless probe factory mounted in supply opening of wall-mount unit: 10k ohm resistance, see Table 2.5 on page 56.

RETURN TEMPERATURE SENSOR

Exposed thermistor-element style with copper-coated steel clip, attached in return opening of wall-mount unit: 10k ohm resistance, see Table 2.5 on page 56.

EVAPORATOR TEMP SENSOR (FREEZESTAT)

Exposed thermistor-element style with copper-coated steel clip, attached to evaporator coil of wall-mount unit: 10k ohm resistance, see Table 2.5 on page 56.

OUTDOOR TEMPERATURE/HUMIDITY SENSOR

Gray, weather-proof octagonal case with dip tube, located in condenser section of wall-mount unit.

- Temperature sensor: 10k ohm resistance, see Table 2.5 on page 56.
- Humidity sensor: 4-20mA.

COMPRESSOR CONTROL MODULE

Compressor protection device that has an adjustable 30-second to 5-minute timer (red-dial). This module features a delay-on-make for initial start-up (or anytime power is interrupted) for a minimum 2 minutes plus 10% of the red-dial setting. There is no delay during routine operation of the unit. The compressor control module (CCM) also monitors the high pressure switch, and will allow one automatic retry (after soft lockout delay) before disabling the compressor in a hard lockout (requires manual reset). If hard lockout does occur, the ALR terminal on the CCM will become active with 24V, which will power the high pressure relay within the wall-mount unit, breaking a digital input to the PLC control—signaling a high-pressure situation to the system.

PHASE MONITOR

Used only on 3-phase equipment, the phase monitor is a compressor protection device that will prohibit operation of the compressor if the device senses a possible reverse-rotation situation due to incorrect phasing. On a call for compressor (and only compressor), the device will check incoming phase, check for severe voltage imbalance and check for proper frequency. Under nominal conditions, a green LED light will show on the face of the monitor. If there is improper phasing, voltage imbalance or frequency deviation, the device will show a red LED light and prohibit compressor operation.

TRANSFORMER

75VA with external 4A circuit breaker, 230VAC/208VAC convertible. Directly feeds power loss relay in wall-mount unit during normal operation. Should loss of utility power occur, transformer failure or transformer external circuit breaker open, the loss of VAC power will cause the contacts within the power loss relay to open, interrupting a digital input to the PLC control—signaling a loss-of-power situation to the system.

FUSED TERMINAL BLOCKS

Black, hinged DIN-rail mount terminal block with an internal glass tube fuse, used in the LC-Series controller for 24VDC power supply to both hydrogen and smoke alarms: Phoenix UK5-HESI

TABLE 2.5
Temperature (F) vs. Resistance (R) of Temperature Sensor

F	R	F	R	F	R	F	R
-25.0	196871	13.0	56985	53.0	19374	89.0	7507
-24.0	190099	14.0	55284	52.0	18867	90.0	7334
-23.0	183585	15.0	53640	53.0	18375	91.0	7165
-22.0	177318	16.0	52051	54.0	17989	92.0	7000
-21.0	171289	17.0	50514	55.0	17434	93.0	6840
-20.0	165487	18.0	49028	56.0	16984	94.0	6683
-19.0	159904	19.0	47590	57.0	16547	95.0	6531
-18.0	154529	20.0	46200	58.0	16122	96.0	6383
-17.0	149355	21.0	44855	59.0	15710	97.0	6239
-16.0	144374	22.0	43554	60.0	15310	98.0	6098
-15.0	139576	23.0	42295	61.0	14921	99.0	5961
-14.0	134956	24.0	41077	62.0	14544	100.0	5827
-13.0	130506	25.0	39898	63.0	14177	101.0	5697
-12.0	126219	26.0	38757	64.0	13820	102.0	5570
-11.0	122089	27.0	37652	65.0	13474	103.0	5446
-10.0	118108	28.0	36583	66.0	13137	104.0	5326
-9.0	114272	29.0	35548	67.0	12810	105.0	5208
-8.0	110575	30.0	34545	68.0	12492	106.0	5094
-7.0	107010	31.0	33574	69.0	12183	107.0	4982
-6.0	103574	32.0	32634	70.0	11883	108.0	4873
-5.0	100260	33.0	31723	71.0	11591	109.0	4767
-4.0	97064	34.0	30840	72.0	11307	110.0	4663
-3.0	93981	35.0	29986	73.0	11031	111.0	4562
-2.0	91008	36.0	29157	74.0	10762	112.0	4464
-1.0	88139	37.0	28355	75.0	10501	113.0	4367
0.0	85371	38.0	27577	76.0	10247	114.0	4274
1.0	82699	39.0	26823	77.0	10000	115.0	4182
2.0	80121	40.0	26092	78.0	9760	116.0	4093
3.0	77632	41.0	25383	79.0	9526	117.0	4006
4.0	75230	42.0	24696	80.0	9299	118.0	3921
5.0	72910	43.0	24030	81.0	9077	119.0	3838
6.0	70670	44.0	23384	82.0	8862	120.0	3757
7.0	68507	45.0	22758	83.0	8653	121.0	3678
8.0	66418	46.0	22150	84.0	8449	122.0	3601
9.0	64399	47.0	21561	85.0	8250	123.0	3526
10.0	62449	48.0	20989	86.0	8057	124.0	3452
11.0	60565	49.0	20435	87.0	7869		
12.0	58745	50.0	19896	88.0	7686		

FUSES

5x20mm time delay, glass tube fuse: 250VAC rated voltage, 35 rated amp interruption at rated voltage: Bussman S506-2.5R

BATTERIES

Used in wall-mount unit and controller boards, flat-disk style BR2330 3V battery. Used only for time/date during complete power loss. Estimated lifespan 7-8 years.

48VDC TO 24VDC POWER CONVERTER

Used in both wall-mount units and LC-Series controller to change shelter-provided 48VDC to 24VDC power for PLC boards, relays, smoke detector and hydrogen detector: Phoenix Quint PS-Series. **NOTE: Output must be minimum 22.8 VDC to allow proper PLC board operation.**

OUTDOOR FAN MOTOR

Due to design considerations of the condenser section of the wall-mount unit, placement/clearance of the motor/fan blade is critical to heat dispersal. Should a

change of motor or fan blade be necessary, please view Figure 2.11 for proper clearance adjustment.

DIRTY FILTER SWITCH

Located inside the blower compartment, this switch measures air pressure differential across the filter (see Figure 2.12). Manual reset only. Default setting: 0.8" static, 50% blocked filter (approximately).

INDOOR BLOWER MOTOR

Unlike most other system fan motors, this motor is a 48VDC motor, and is very specialized in application. Please see Table 2.6 (blower table).

PHOENIX ISOLATION RELAY: WALL-MOUNT UNIT

Green DIN-Rail mount isolation relay used in the wall-mount unit to isolate/filter 48VDC power, motor speed signal and ground from the PLC board: Phoenix Mini MCR-Style.

ZETTLER ISOLATION RELAYS: WALL-MOUNT UNIT

Black Zettler surface mount relays used in the wall-mount unit to isolate the start signal from:

- Power loss relay circuit (see Figure 2.13 on page 58)
- High pressure relay circuit (see Figure 2.14 on page 58)
- Blower motor start signal relay circuit (see Figure 2.15 on page 58)

ISOLATION RELAYS: LC-CONTROLLER

Blue DIN-Rail mount isolation relays used in the controller to isolate the PLC board from varying voltages within the same shelter.

**FIGURE 2.11
Fan Blade Setting**

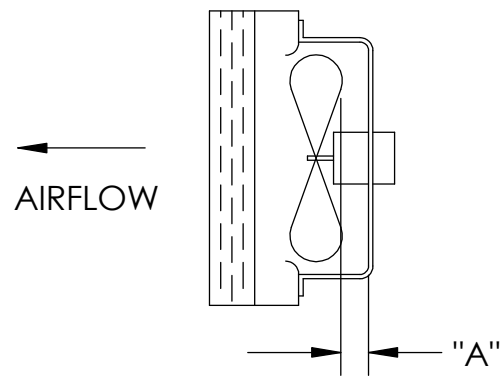

MIS-1724

Model	Dimension A
All covered by this manual	1.75"

**FIGURE 2.12
Dirty Filter Switch**



**TABLE 2.6
Indoor Blower Performance**

MODEL	RATED ESP	MAX ESP	FREE COOLING CFM ABOVE 40°	FREE COOLING CFM BELOW 40° ①	RATED FULL LOAD COOLING CFM	ELECTRIC HEAT AIRFLOW
D28A/D28L	0.10	0.50	1800	800	1100	1800
D36A/D36L	0.15	0.50	1800	800	1100	1800
D42A/D42L	0.20	0.50	1800	950	1250	1800
D48A/D48L	0.20	0.50	1800	1100	1600	1800
D60A/D60L	0.20	0.50	1800	1100	1600	1800

① PLC controller derives at this decision point and switches the indoor motor speed. The damper actuator will then adjust to still yield a 55°F supply air temperature.

FIGURE 2.13
Power Loss Relay Circuit

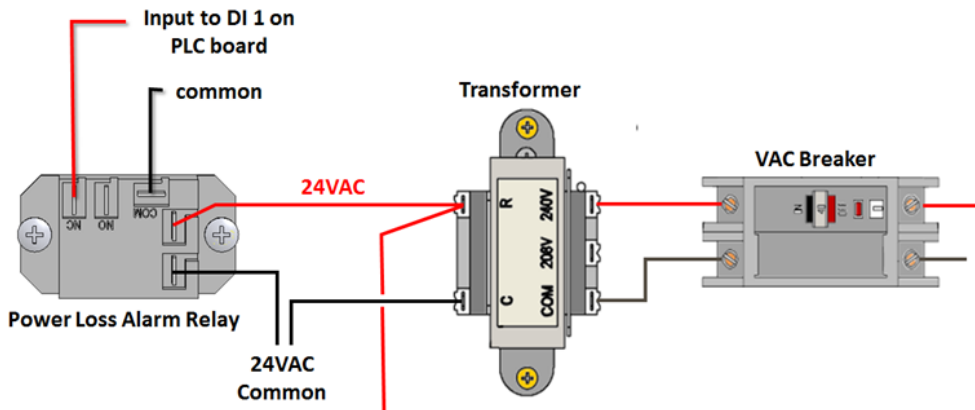

FIGURE 2.14
High Pressure Relay Circuit

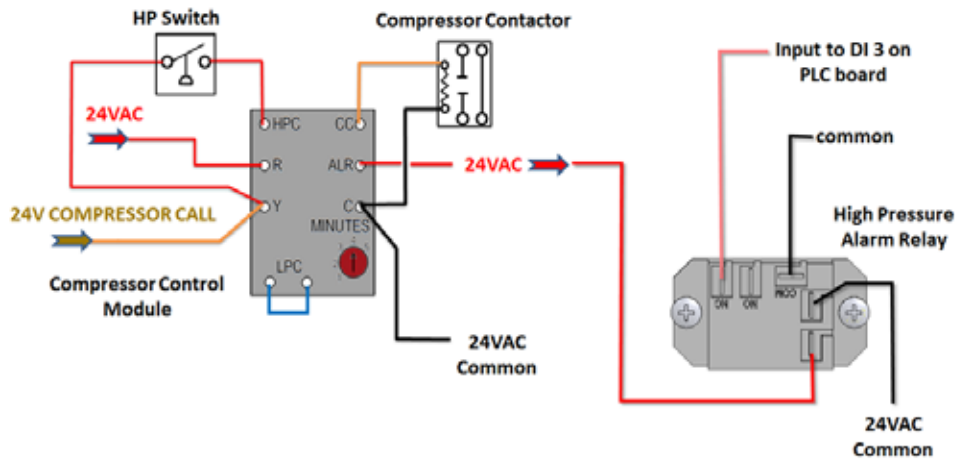

FIGURE 2.15
Blower Motor Start Relay Circuit

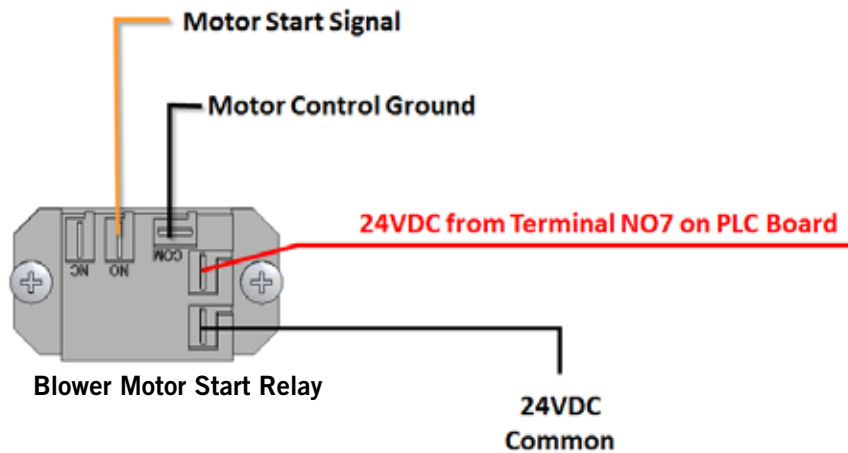

FIGURE 2.16
Unit Control Panel

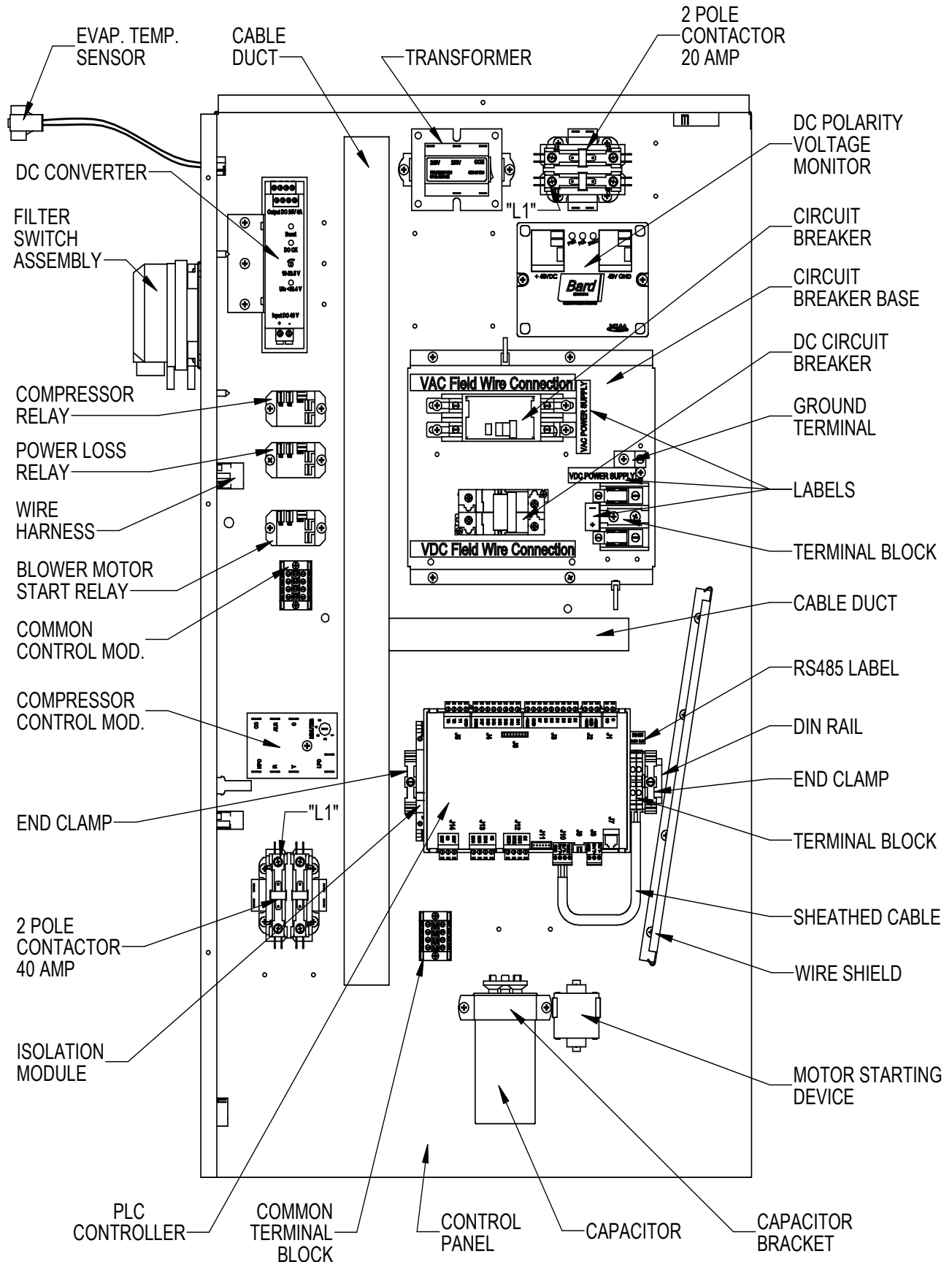
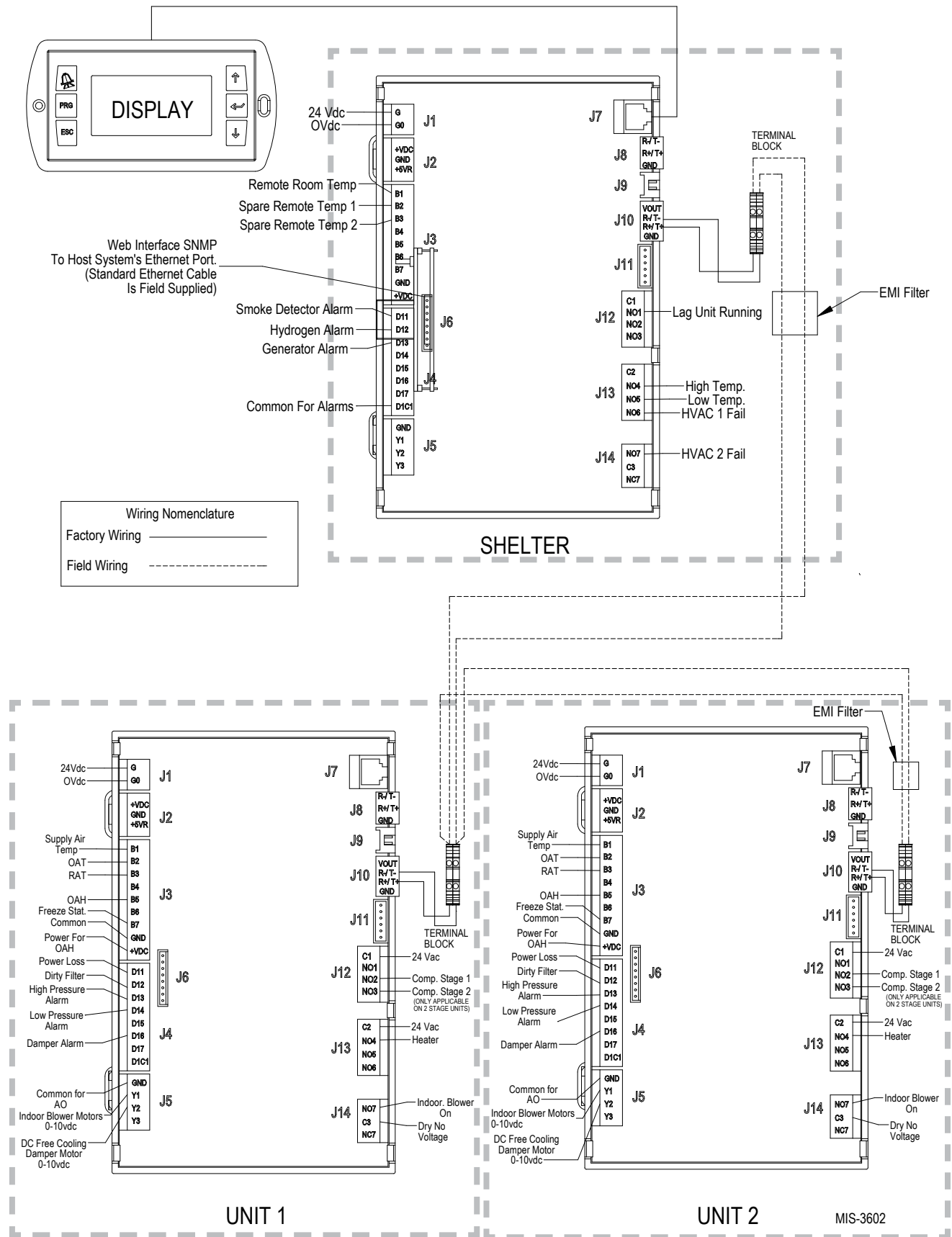

FIGURE 2.18
Low Voltage Connections



MAINTENANCE AND TROUBLESHOOTING

STANDARD MAINTENANCE PROCEDURES

WARNING

Electrical shock hazard.

Disconnect both VAC and VDC power supplies before servicing.

Failure to do so could result in electric shock or death.

CAUTION

Cut hazard.

Wear gloves to avoid contact with sharp edges.

Failure to do so could result in personal injury.

1. Disable system from LC controller (see Advanced Programming section).
2. Turn off both AC and DC breakers at wall-mount units.
3. Check inlet sides of condenser and evaporator coils for obstructions/debris—clean if necessary using a quality manufactured coil cleaning product specific for the evaporator or condenser coil.
 - Condenser coil: Remove the fan shroud/motor/motor bracket as an assembly from the condenser section. This will give clear access to the inlet side of the coil for cleaning. Follow the coil cleaner manufacturer's directions for necessary safety gear and precautions, as well as for application and use. More than one application may be necessary. Rinse thoroughly.
 - Evaporator coil: Remove the evaporator section panel and apply specific evaporator cleaner directly to the inlet side of coil, being very careful not to overspray into insulation or surrounding panels and wiring. Residual cleaner and dissolved debris should drip into the drain pan and leave the unit through the condensate hose. More than one application may be necessary. Rinse thoroughly.
4. Manually spin fan and blower motors to ensure they turn freely. All motors are permanently lubricated, so no oil is necessary.
5. Inspect free cooling damper actuator and linkage.
6. Install new air filter; check for additional filter grilles internal to the structure.
7. Inspect the control panel of the system.
 - Look for insect or rodent activity and remove any nesting materials.
 - Manually push contactor closed, observe for movement—contactor points should have minimal discoloration, no spalling or other signs of arcing. Replace if doubtful.
 - Check field and factory wiring for tightness and look for signs of overheating (discoloration of terminals or wire insulation).
8. Ensure that supply and return registers are not obstructed, and more importantly, are not recycling the air to one another. Adjust supply louvers if necessary to direct discharge air away from any direct route to the return grille.
9. Re-assemble wall-mount unit and turn breakers back on.
10. Enable system from LC controller (see Advanced Programming section).
11. Repeat steps for second wall-mount unit.

SPECIFIC TROUBLESHOOTING – 48VDC Blower Motor

To troubleshoot the 48VDC blower motor, check for proper voltage and commands to the motor controller from the wall-mount unit. Under a command for blower,

disconnect the 9-pin Molex plug connecting the motor control to the wall-mount unit control wiring harness (this Molex is located in the chassis wall of the control panel) and test for the items in Table 2.7 (see Figure 2.19 below and Figures 2.20 and 2.21 on page 64).

TABLE 2.7
Troubleshooting the 48VDC Indoor Blower Motor

Motor Controller Molex Plug	Color	Function	Description of Application
1	Red	SPEED INPUT	0-10 VDC input, varying voltage input between 0-10 VDC dictates the motor speed/CFM delivery
2			
3			
4	Orange	RUN	Start Command – a contact closure between this wire and the control ground (Pin 5) will issue and order for the motor to start.
5	Black	CONTROL GROUND	Control Ground for both start-stop function and speed control voltage
6			
7	Red	52 VDC (+)	"+" VDC power supplied to motor
8			
9	Black	52 VDC (-)	"-" VDC power supplied to motor

FIGURE 2.19
Troubleshooting Motor Power Supply

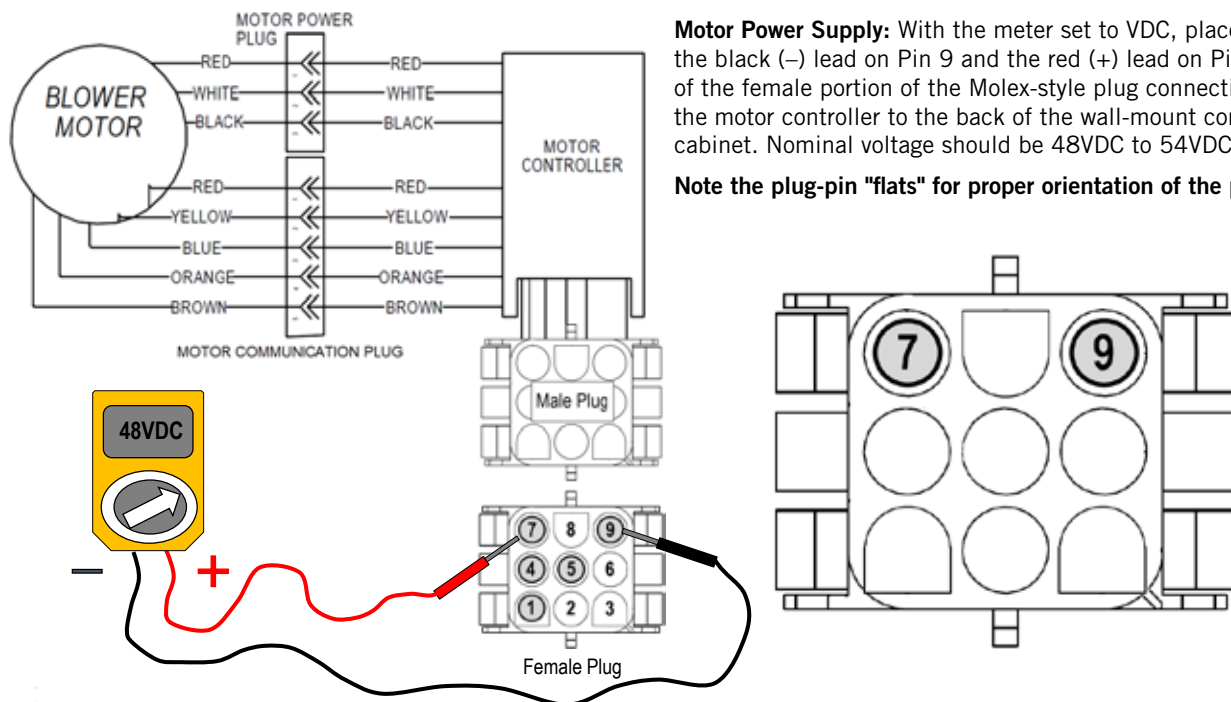
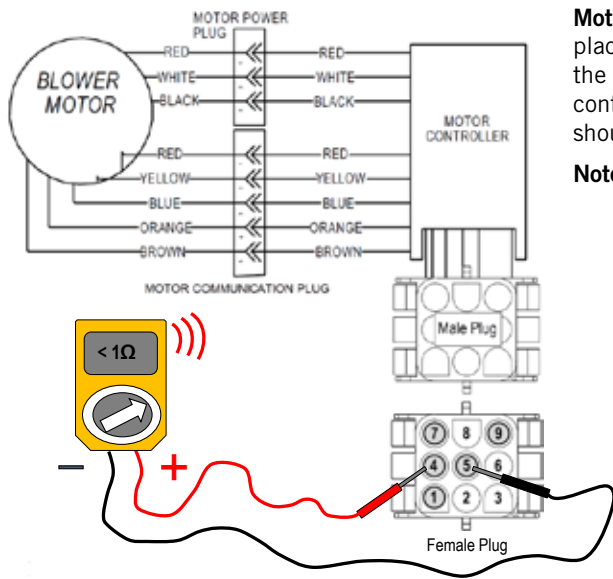

FIGURE 2.20
Troubleshooting Motor Start Command



Motor Start Command: With the meter set to Continuity Beeper, place the black (-) lead on Pin 5 and the red (+) lead on Pin 4 of the female portion of the Molex-style plug connecting the motor controller to the back of the wall-mount control cabinet. Meter should audibly alert a closed-contact condition.

Note the plug-pin "flats" for proper orientation of the plug.

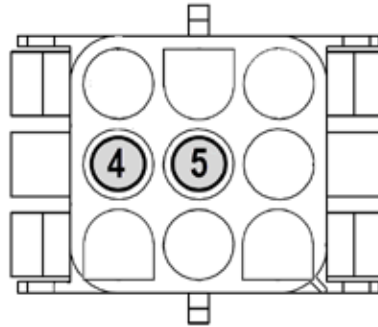
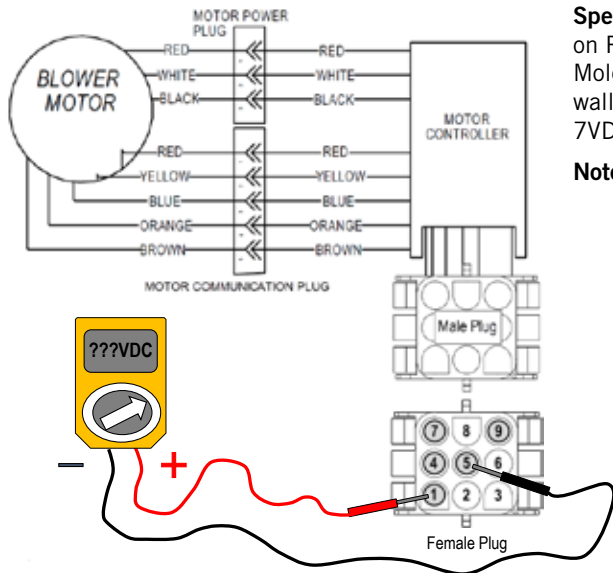

FIGURE 2.21
Troubleshooting Speed Voltage



Speed Voltage: With the meter set to VDC, place the black (-) lead on Pin 5 and the red (+) lead on Pin 1 of the female portion of the Molex-style plug connecting the motor controller to the back of the wall-mount control cabinet. Nominal voltage should be 2.8VDC to 7VDC. Reference Table 2.8 for exact voltage.

Note the plug-pin "flats" for proper orientation of the plug.

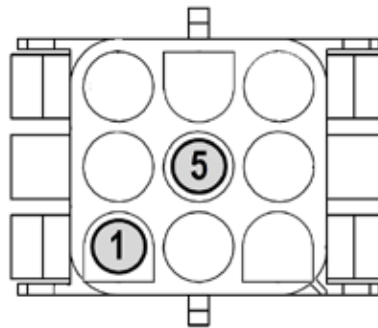
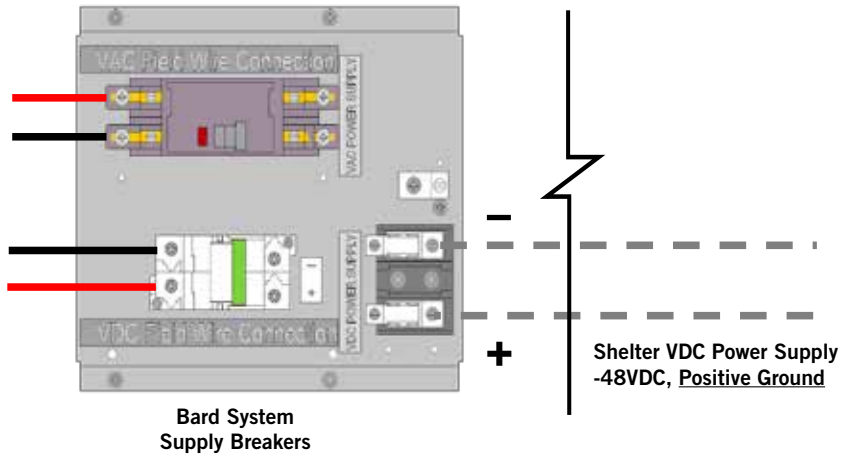

TABLE 2.8
Blower Speed Voltage Chart

Model	Blower Only	Free Cooling Mode (CFM/VDC Speed Voltage)	Free Cooling Mode Below 40°F (CFM/VDC Speed Voltage)	Cooling (CFM/VDC Speed Voltage)	Electric Heat
D28A/D28L	Same as Free Cooling Mode	1800/7.0	800/2.8	1100/3.8	1800/7.0
D36A/D36L			800/2.8	1100/3.8	
D42A/D42L			950/3.1	1250/4.7	
D48A/D48L			1100/3.8	1600/6.3	
D60A/D60L			1100/3.8	1600/6.3	

FIGURE 2.22
VDC Polarity Check

If the VDC wiring is not terminated correctly on the specific polarity-indicated terminals of the VDC terminal block, the VDC controls and motors will not activate and the wall-mounted unit will not function.



Step 1
Multimeter set to VDC:
Display reveals "0" voltage potential

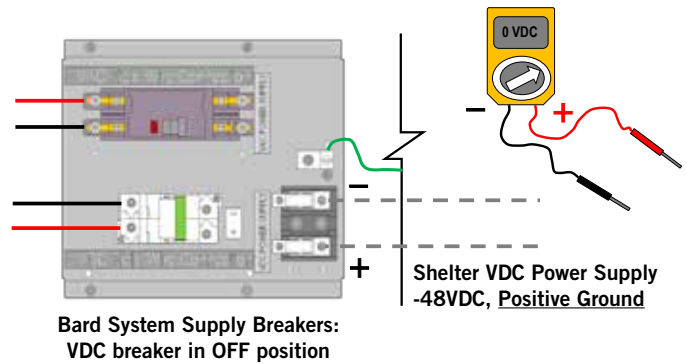

Step 2
Multimeter set to VDC:
Positive-to-ground reveals
"0" voltage potential

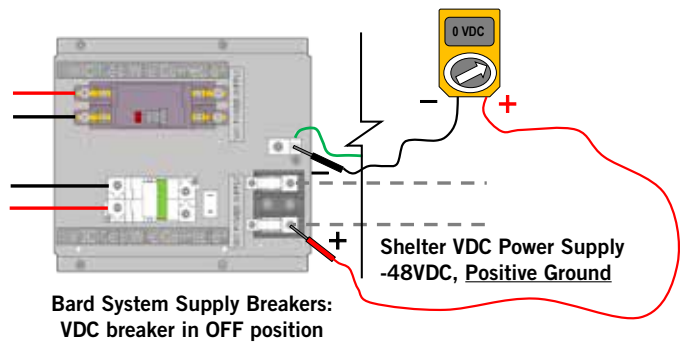

Step 3
Multimeter set to VDC:
Negative-to-ground reveals
"-48" voltage potential

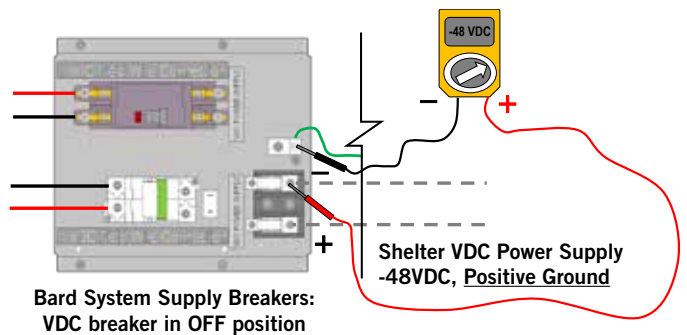
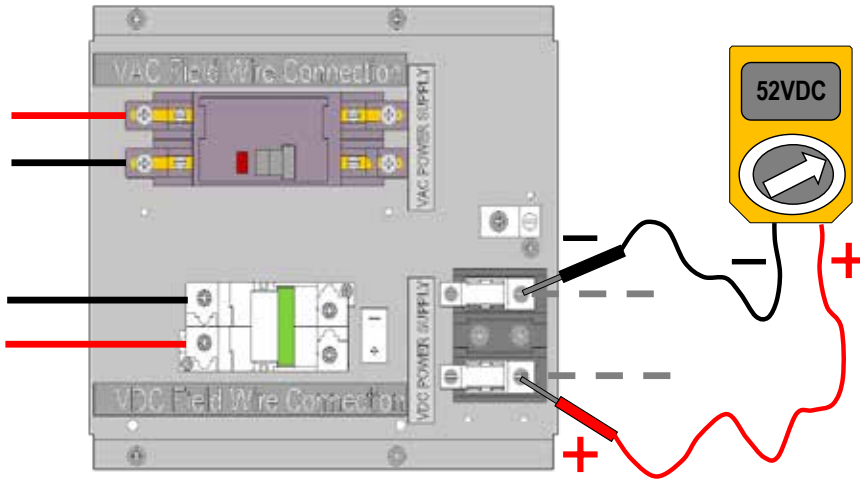

FIGURE 2.23
Verifying Incoming Voltage: VDC

Multimeter set to VDC



48VDC Shelter System
Voltage Range:
40VDC – 56VDC

Typical Running Range:
48VDC – 53VDC

Shelter supply breaker in ON position
Bard system breaker in OFF position

Displayed voltage must be within this range

TROUBLESHOOTING LC2000-100 CONTROLLER AND TEC-EYE ALARMS

The LC2000-1000 controller is designed for continuous and dependable operation. In the event that a problem is encountered with the A/C system, the system controller may be used to diagnose the cause. The system controller will display alarms for the entire system; the TEC-EYE hand-held tool will only display alarms for an individual unit.

The controller signals an alarm condition when the red backlight LED is illuminated behind the alarm key. An alarm indication is accompanied by a screen text message of the cause. Often the remedy is simple to determine by reading the alarm message, i.e., "Dirty Filter" (replace filter). The following guidelines are included to assist in troubleshooting the system due to operational or performance problems. If the problem can't be resolved using the alarm screens and these guidelines, contact the BARD Technical Service Department at 419.636.0439 for assistance.

TROUBLESHOOTING BARD-LINK™ CONTROLLER ALARMS

Signal	Description	Possible Cause	Component to Check	Recommended Action	Device Actions
Smoke/Fire Alarm	The entire unit(s) stops working. The alarm resets automatically.	Fire/smoke detector is triggered	Check the external fire/smoke detector	Replace the external fire/smoke detector	Indoor Blower: Off Compressor/Condensator Fan: Off Heat: Off Damper: Closed
		Check if the connection to the corresponding input is ok or if the PLC controller board is defective.	Check if the connection is ok.	Reconnect the cable. If the controller board is defective, replace it.	
High Temperature Alarm	Alarm is reset automatically. Occurs when the current indoor temperature is greater than the 2nd high temperature alarm setpoint value. The default is 95°F.	The cooling capacity loss or heat load loss is too great.	Check for leakages in the refrigerant circuit. Check if heat load exceeds the design range.	Remove the leakage. Increase the cooling capacity.	Compressor/Condensator Fan: Off
		Compressor circuit failure.	Check if components connected to the compressor are ok. Check if compressor is ok. Check if the electric connection is ok.	Replace the defective components. Replace the compressor. Reconnect the cables.	
		Indoor temperature sensor failure.	Check if the sensor is shorted or has failed.	Replace the indoor temperature sensor.	
		Incorrect value set for the high temperature alarm.	Check if value is correct.	Correct the value.	
Low Temperature Alarm	Alarm can be reset automatically. Occurs when the current indoor temperature is less than the indoor temperature setpoint value minus the temperature alarm offset. The default is 45°F.	Heating capacity loss.	Check if the heaters are ok. Check for leaks around the unit.	If heaters have failed, replace them. Seal the leaks.	
		Indoor temperature sensor failure.	Check for a short in the sensor or if it has failed.	Replace the indoor temperature sensor.	
		Incorrect value set for the high temperature alarm.	Check if the value is correct.	Correct the value.	
Hydrogen Alarm	The indoor controller will activate Emergency Ventilation mode to exhaust any noxious gases from building to introduce outside fresh air. The alarm resets automatically.	Hydrogen detector is triggered.	Check the external hydrogen detector.	Replace the external hydrogen detector.	Indoor Blower: On Compressor/Condensator Fan: On Heat: On Damper: On
		Check if connection to the corresponding input terminal is ok or if the PLC controller is defective.	Check if the connection is ok.	Reconnect the cable. If the PLC controller board is defective, replace it.	

TROUBLESHOOTING BARD-LINK™ CONTROLLER ALARMS (CONT.)

Signal	Description	Possible Cause	Component to Check	Recommended Action	Device Actions
Generator Run Alarm	The indoor controller will activate an emergency ventilation mode on an input from generator run alarm which enables DC free cooling mode and will only allow lead unit to run in mechanical cooling as needed to satisfy any temperature. The alarm resets automatically.	Generator run is triggered. Check if connection to the corresponding input terminal is ok or if the PLC controller is defective.	Check if the connection is ok.	Reconnect the cable. If the PLC controller board is defective, replace it.	Indoor Blower: On Compressor/Condensor Fan: On Heat: On Damper: On
Remote Indoor Temperature Sensor Failed Alarm (B01)	The alarm is activated if the sensor is faulty, a sensor wire is loose or an out-of-range value is read.	The alarm is activated if the sensor is faulty, a sensor wire is loose or an out-of-range value is read.	Configuration should be "0" if only the remote indoor temperature sensor supplied with controller is installed.* Check the indoor temperature sensor wiring. Check temperature vs. resistance of temperature sensor (see Table 2.5 on page 56).	Replace the indoor temperature sensor.	
Spare Remote Indoor Temperature 1 Sensor Failed Alarm (B02)	The alarm is activated if the sensor is faulty, a sensor wire is loose or an out-of-range value is read.	The alarm is activated if the sensor is faulty, a sensor wire is loose or an out-of-range value is read.	Configuration should be "1" if a single <i>additional</i> remote indoor temperature sensor is installed.* Check the spare remote 1 temperature sensor wiring. Check temperature vs. resistance of temperature sensor (see Table 2.5 on page 56).	Replace the spare remote 1 temperature sensor.	
Spare Remote Indoor Temperature 2 Sensor Failed Alarm (B03)	The alarm is activated if the sensor is faulty, a sensor wire is loose or an out-of-range value is read.	The alarm is activated if the sensor is faulty, a sensor wire is loose or an out-of-range value is read.	Configuration should be "2" if two <i>additional</i> remote indoor temperature sensors are installed.* Check the spare remote 2 temperature sensor wiring. Check temperature vs. resistance of temperature sensor (see Table 2.5 on page 56).	Replace the spare remote 2 temperature sensor.	

* See **Configuring Additional Remote Indoor Temperature Sensors** on page 49.

TROUBLESHOOTING TEC-EYE ALARMS

Signal	Description	Possible Cause	Component to Check	Recommended Action	Device Actions
Low Pressure Alarm	If the alarm activates once or twice in an hour, it is reset automatically. If it occurs three times in an hour, the compressor and condenser fan are locked.	Lack of refrigerant	Run the unit and check if the low pressure value is in the normal range.	Charge appropriate amount of refrigeration.	Compressor/ Condenser Fan: Off
		The switch is defective.	Check if the pressure switch is OK.	If defective, replace.	
		Check if the connection to the corresponding input terminal is ok or if the controller board is defective.	Check if the connection is OK. Check is the controller board is OK.	Reconnect the cables. If the PLC controller is defective, replace.	
High Pressure Alarm	If the alarm activates once or twice in an hour, it is reset automatically. If it occurs three times in an hour, the compressor and condenser fan are locked.	Abnormal site condition	Check open door or for abnormal site condition. Check if the high pressure value is in the normal range.	Clean the condenser.	Compressor/ Condenser Fan: Off
		Condenser fan has failed. The condenser fan speed controller has failed.	Check the condenser fan status while the high pressure is outside the normal setting.	Replace the condenser fan. Replace the condenser low ambient (fan speed) controller.	
		The switch is defective.	Check if the high pressure switch is OK.	If defective, replace.	
		Check if the connection to the corresponding input terminal is ok or if the controller board is defective.	Check if the connection is OK. Check is the controller board is OK.	Reconnect the cables. If the PLC controller is defective, replace.	
Landline/Shore/ Prime Power Outage	Alarm is reset automatically.	Primary power has gone off.			Indoor Blower: On Compressor/ Condenser Fan: Off Heat: Off Damper: On
Dirty Air Filter Alarm	The alarm is a warning to check the filter. Alarm can only be reset manually.	Filter is clogged.	Check if the filter is dirty.	Clean or replace the filter.	
		Check if the connection to the corresponding input terminal is OK or if the PLC controller board is defective.	Check if the connection is OK.	Reconnect the cable. If the PLC controller board is defective, replace.	
		The value set for the differential air pressure switch is too low.	Check the differential air pressure switch value.	Correct the value of the switch to standard value.	
DC Free Cooling Damper Fails to Open Alarm	Alarm is reset automatically.	DC free cooling damper fails to open.	Check the damper linkage. Check to see if anything is in the way of the damper.		Indoor Blower: On Damper: Off

TROUBLESHOOTING TEC-EYE ALARMS (CONT.)

Signal	Description	Possible Cause	Component to Check	Recommended Action	Device Actions
DC Free Cooling Damper Fails to Close Alarm	Alarm is reset automatically.	DC free cooling damper fails to close.	Check the damper linkage. Check to see if anything is in the way of the damper.		Indoor Blower: On Damper: Off
Communication Failed Alarm	Alarm is reset automatically.	Communication is lost with the LC2000-100 main controller.	Check the RS485 port. Check for damage to the communications cable between the PLC controllers.	Reconnect the communications cable. If the PLC controller board RS485 port is defective, replace.	
Supply Air Temperature Sensor Failed Alarm (B01)	The alarm is activated if the sensor is faulty, a sensor wire is loose or an out-of-range value is read.	The alarm is activated if the sensor is faulty, a sensor wire is loose or an out-of-range value is read.	Check the supply air temperature sensor wiring. Check temperature vs. resistance of temperature sensor (see Table 2.5 on page 56).	Replace the supply air temperature sensor.	
Outdoor Temperature Sensor Failed Alarm (B02)	The alarm is activated if the sensor is faulty, a sensor wire is loose or an out-of-range value is read.	The alarm is activated if the sensor is faulty, a sensor wire is loose or an out-of-range value is read.	Check the outdoor temperature sensor wiring. Check temperature vs. resistance of temperature sensor (see Table 2.5 on page 56).	Replace the outdoor temperature sensor.	
Outdoor Humidity Sensor Failed Alarm (B05)	The alarm is activated if the sensor is faulty, a sensor wire is loose or an out-of-range value is read.	The alarm is activated if the sensor is faulty, a sensor wire is loose or an out-of-range value is read.	Check the humidity sensor wiring.	Replace the humidity sensor.	
Return Air Temperature Sensor Failed Alarm (B03)	The alarm is activated if the sensor is faulty, a sensor wire is loose or an out-of-range value is read.	The alarm is activated if the sensor is faulty, a sensor wire is loose or an out-of-range value is read.	Check the return air temperature sensor wiring. Check temperature vs. resistance of temperature sensor (see Table 2.5 on page 56).	Replace the return air temperature sensor.	

NEED ASSISTANCE?

This document contains the most current product information as of this printing. For the most up-to-date product information, go to www.bardhvac.com where there are links to product specifications, installation instructions, replacement parts manuals and wiring diagrams. Should any assistance be required during the installation or servicing of this product, contact the Bard Technical Service Department at 419.636.0439.

SECTION 3: **APPENDICES**

APPENDIX 1: LC-SERIES CONTROLLER ARCHITECTURE

CAUTION: The Bard DC-FCU System has been pre-programmed with what is widely considered to be the best settings for efficiency and operation. Any changes to internal programming through the LC-Series Controller or the TEC-EYE not covered within this manual may cause the systems to operate improperly, cause internal damage to the HVAC units, cause the shelter to overheat or other very serious consequences. Although complete controller programming architecture for both the LC-Controller and TEC-EYE has been provided, going outside the boundaries of what has been covered in this manual not recommended.

Screen	Menu Item	Value	Description
Status Screen	(Use UP/DOWN arrow keys to scroll)		Displays current data
	Space Temp	(Current Temp)	
	Setpoint	°F Setpoint	
	Unit 1 Blower	Off/On	Displays status of blower
	Unit 1 Damper	%	Displays percentage of current opening
	Unit 1 Compressor	C1/nothing	Displays status of compressor
	Unit 2 Blower	Off/On	Displays status of blower
	Unit 2 Damper	%	Displays percentage of current opening
	Unit 2 Compressor	C2/nothing	Displays status of compressor
	Status	Unit On	LC-Series controller is currently enabled ("Off by Keypad" if disabled in controller)
	U1	Online	Verification of communication with Unit 1
	U2	Online	Verification of communication with Unit 2
	Unit 1/Unit 2 SAT	°F	Supply air temperature (discharge air temperature)
	Unit 1/Unit 2 RAT	°F	Return air temperature
	Unit 1/Unit 2 OAT	°F	Outdoor air temperature
	Unit 1/Unit 2 OAH	%H	Outdoor air humidity
	DEW		
	Last Hour Averages		Averages from last hour of operation
	Inside Temp Avg	°F	
	Outside Temp Avg	°F	
	Outside Hum Avg	%H	
	OA Dewpoint Avg	°F	
	Last Hour Tracking		Statistics from last 60 min of operation
	Free Cool U1/U2 Run	Minutes	Running minutes of damper activation
	Free Cool U1/U2 Start	#	Damper initiations
	Compressor 1 U1/U2 Run	Minutes	Compressor run time (single stage units or 1st stage compressor of 2-stage units)
	Compressor 1 U1/U2 Start	#	Compressor initiations (single stage units or 1st stage compressor of 2-stage units)
	Compressor 2 U1/U2 Run	Minutes	2nd stage compressor run time
	Compressor 2 U1/U2 Start	#	2nd stage initiations

Screen	Menu Item	Value	Description
	Heating U1/U2 Run	Minutes	Heating run time
	Heating U1/U2 Start	#	Heating initiations
Main Menu	(MENU key to enter, use UP/DOWN arrow keys to scroll)		
	On/Off Unit		
	Unit Address	1	Physical address of controller
	Power by Display On/Off		
	Status	On	"OFF by Keyboard" system has been turned off at controller
	Setpoints	All setpoint changes are limited to 60 minutes	
	Cooling Setpoint	77°F	
	Heating Setpoint	60°F	
	Cooling Stg. Diff.	5°F	
	Heating Stg. Diff.	2°F	
	Stage Delay	10 seconds	
	FreeCool	55°F	
	FreeCool Enable	50°F	
	Differential	10°F	
	DC OA-Return Diff.	10°F	
	Supply Temp Low Limit	45°F	
	Differential	5°F	
	Alarm Delay	10 seconds	
	Run Test Time	60 seconds	
	Low Alarm	45°F	
	High Alarm	85°F	
	High Alarm 2	90°F	
	Blower Settings		
	Continuous	None	"Lead Only" or "Both" also available
	Blower Speeds		
	Heat	7.0V	Control voltage supplied from wall-mount unit control boards to blower in heat
	Econ	7.0V	Control voltage supplied from wall-mount unit control boards to blower in regular DC free cooling
	Econ Low Temp	3.8V	Control voltage supplied from wall-mount unit control boards to blower in low ambient condition DC free cooling
	Full Load	6.3V	Control voltage supplied from wall-mount unit control boards to blower in mechanical cooling

APPENDIX 1: LC-SERIES CONTROLLER ARCHITECTURE (CONT.)

Screen	Menu Item	Value	Description
	Low Pressure Setup		
	Outside Setpoint	55°F	Temperature at which control separates two (2) different low pressure situations
	Differential	5°F	This differential applies to the outside setpoint
	Above Setpoint Delay	120 seconds	Any low pressure situation above the outside setpoint will be delayed 120 seconds before an alarm is initialized
	Below Setpoint Delay	180 seconds	Any low pressure situation below the outside setpoint will be delayed 180 seconds before an alarm is initialized
	Coastal Mode	On (if applicable)	Automatically controlled cancellation of DC free cooling feature for those situations with corrosive environments
	Comfort Mode	60 minutes	Setpoint of 72 is maintained for 60 minutes for technician comfort
	Comfort Setpoint	72°F	Setpoint of 72 is maintained for 60 minutes for technician comfort
	Number of Units	2	Amount of systems connected to controller (choice of 1 or 2). See page 36.
	Clock/Scheduler		
	Date	(Current date)	
	Hour	(Current time)	
	Day	(Current day of week)	
	Unit Rotation	1 or 2	Which unit is currently in lead status
	Switch Lead	No	Change to "Yes" to advance lead status to other unit
	By Time	Yes	Units will lead/lag advance based on days
	Rotate Days	1	Units will lead/lag advance in this increment
	By Alarm	Yes	HP, LP, Power Loss, Freezestat, and Communication loss will also advance
	By Demand	Yes	
	Clock		
	Daylight Savings Time	Enable	System Clock will follow DST Protocol, "Disable" if desired
	Transition Time	60 minutes	
	Start	Last Sunday in March 2am	
	End	Last Sunday in Oct 3am	
	Number of Units	2	Amount of systems connected to controller
	Inputs/Outputs		
	Analog Inputs		
	Indoor Temp Input B001	(Current Temp)	

Screen	Menu Item	Value	Description
	Digital Inputs		
	Smoke Detector DI 1 Status	Open	
	Hyd. Detector DI 2 Status	Open	
	Generator Run DI 3 Status	Open	
	Relay Outputs		
	Smoke Alarm Relay 1 Status	On	
	High Temp 2 Relay 4 Status	On	
	Low Temp Relay 5 Status	On	
	HVAC 1 Fail Relay 6 Status	On	
	HVAC 2 Fail Relay 7 Status	On	
	Lag Unit Run Relay 8 Status	On	
	Alarm History		Use the Up/Down arrows to scroll through the latest alarms/conditions
	Technician Information		
	Bard Code	Inside controller	"Unit Controller" would be a pre-programmed wall-mount unit board
	Version	(Current version)	
	Bios	(Current bios)	
	Root	(Current root)	
	Flashram	N/A	Internal memory specifications
	Power Cycle	N/A	Count of power initiations
	BMS Configuration		
	BMS Port 1 Protocol	Carel	
	BMS Port 1 Address	1	
	BMS Baud Rate	19200	
	Service Settings		
	Probe Adjustment		
	Input B01 Offset	0	Calibrating indoor sensor if necessary
	Input B01 Value	(Current Temp)	Current temperature plus offset
	Control Settings		
	Remote Sensors	0	Enter the amount of extra remote sensors
	Control to	Average	Choose "Average" or "Highest"
	U1 Run Test	No	"Yes" to begin Run Test Unit 1
	U2 Run Test	No	"Yes" to begin Run Test Unit 2
	Manual Management		
	Analog Inputs		
	Manual Control B001	Off	On to manually change temperature seen by controller

APPENDIX 1: LC-SERIES CONTROLLER ARCHITECTURE (CONT.)

Screen	Menu Item	Value	Description
	Manual Position	0	Degrees of change in sensor for manual control
	Value	(Temp + Value)	Current temperature plus the value in manual position
	Digital Inputs		
	Smoke Manual DI 1	Off	"On" to allow artificial manipulation of smoke alarm input
	Manual Position	Open/Closed	Change to "Closed" to artificially create smoke alarm input
	D1 Status	Open	Current status of smoke alarm input (open means no input)
	Hydrogen Manual DI 2	Off	"On" to allow artificial manipulation of hydrogen alarm input
	Manual Position	Open/Closed	Change to "Closed" to artificially create hydrogen alarm input
	D2 Status	Open	Current status of hydrogen alarm input (open means no input)
	Generator Run DI 3	Off	"On" to allow artificial manipulation of generator run input
	Manual Position	Closed	Change to "Closed" to artificially create generator run input
	D3 Status	Open	Current status of generator run input (open means no input)
	Relay Outputs		
	Smoke Manual Relay 1	Off	"On" to allow artificial manipulation of smoke alarm relay action
	Manual Position	On/Off	Change to "Off" to artificially force smoke alarm relay
	Relay 1 Status	On	Current status of smoke alarm relay (on means no relay action)
	High Temp Relay 4	Off	"On" to allow artificial manipulation of high temp alarm relay action
	Manual Position	On/Off	Change to "Off" to artificially force high temp alarm relay
	Relay 4 Status	On	Current status of high temp alarm relay (on means no relay action)
	Low Temp Relay 5	Off	"On" to allow artificial manipulation of low temp alarm relay action
	Manual Position	On/Off	Change to "Off" to artificially force low temp alarm relay
	Relay 5 Status	On	Current status of low temp alarm relay (on means no relay action)
	HVAC 1 Fail Relay 6	Off	"On" to allow artificial manipulation of HVAC 1 fail relay action
	Manual Position	On/Off	Change to "Off" to artificially force HVAC 1 fail relay action
	Relay 6 Status	On	Current status of HVAC 1 fail relay (on means no relay action)

Screen	Menu Item	Value	Description
	HVAC 2 Fail Relay 7	Off	"On" to allow artificial manipulation of HVAC 2 fail relay action
	Manual Position	On/Off	Change to "Off" to artificially force HVAC 2 fail relay action
	Relay 7 Status	On	Current Status of HVAC 2 Fail Relay (On means no relay action)
	Lag Unit Run Relay 8	Off	"On" to allow artificial manipulation of Lag Unit Run Alarm Relay action
	Manual Position	On/Off	Change to "Off" to artificially force Lag Unit Run Relay action
	Relay 8 Status	On	Current Status of Lag Unit Run Alarm Relay (On means no relay Action)
	Factory		
	Configuration		
	Temperature Units	°F	°C units available as well
	Pressure Units	PSI	N/A
	Force Clock Enable	Yes	
	Clock Mode	24 hour	12 hour available
	Disable Buzzer	Yes	Audible buzzer available
	Startup Delay	1 second	
	Enable Unit	On/Off	
	By digit input	Off	N/A
	By supervisor	Off	N/A
	By pLAN network	Off	N/A
	By schedule	Off	N/A
	Unit Control		
	Custom 1	Off	N/A
	Custom 2	Off	N/A
	Custom 3	Off	N/A
	Custom 4	Off	N/A
	Analog Input Fitering		
	Enable	No	N/A
	Input 1	19 seconds	N/A
	Input 2	19 seconds	N/A
	Input 3	19 seconds	N/A
	Input 4	19 seconds	N/A
	Input 5	19 seconds	N/A
	Factory Settings		
	Manual Cont. Reset Enable	Yes	
	Time	5 minutes	
	Local Setpoint Reset	60 minutes	Allows only 60 minutes for setpoint changes
	PW/Return Delay	300 seconds	Display goes to status page and backlight shuts off in 5 minutes

APPENDIX 1: LC-SERIES CONTROLLER ARCHITECTURE (CONT.)

Screen	Menu Item	Value	Description
	Scheduler		
	Number of Schedules	0	N/A
	Optimized Start	No	N/A
	Set 1 Adjust	No	N/A
	Set 2 Adjust	No	N/A
	Holidays		
	Number	0	N/A
	Initialization		
	Default Installation	No	Change to "Yes" to reset to factory default values. NOTE: Be sure to enter the serial number and model number for unit to operate with correct blower speed voltage.

APPENDIX 2: TEC-EYE ARCHITECTURE

CAUTION: The Bard DC-FCU System has been pre-programmed with what is widely considered to be the best settings for efficiency and operation. Any changes to internal programming through the LC-Series Controller or the TEC-EYE not covered within this manual may cause the systems to operate improperly, cause internal damage to the HVAC units, cause the shelter to overheat or other very serious consequences. Although complete controller programming architecture for both the LC-Controller and TEC-EYE has been provided, going outside the boundaries of what has been covered in this manual not recommended.

Screen	Menu Item	Value	Description
Status Screen	The Status screen is the default screen on startup, and anytime more than 5 minutes has elapsed from last change. (Use UP/DOWN arrow keys to scroll)		Displays current data
	RAT	°F	Current return air temperature
	SAT	°F	Current supply air temperature
	OAT	°F	Current outdoor air temperature
	OAH	%	Current outdoor air humidity
	Dewpoint	°F	Current temperature of dewpoint
	Blower	Off/On	Displays status of blower
	Damper	%	Displays percentage of current opening
	Master Control	Master Control	Current operational status, "Running Stand Alone" if communication lost
	Status	Unit On	D-Series controller board is currently active, "Off by Keyboard" if disabled by TEC-EYE
Main Menu	Main Menu screen(s) allows access to operational programming, access by pressing MENU key at any time. (MENU key to enter, use UP/DOWN arrow keys to scroll)		
	On/Off Unit		
	Unit Address	1	Physical address of controller
	Power by Display On/Off		
	Status	On	"OFF by Keyboard" system has been turned off at controller
	Setpoint		
	Cooling Setpoint	77°F	
	Heating Setpoint	60°F	
	Cooling Stg. Diff.	5°F	
	Heating Stg. Diff.	2°F	
	FreeCool	55°F	
	FreeCool Enable	50°F	
	Differential	10°F	
	DC OA-Return Diff.	10°F	
	Supply Temp Low Limit	45°F	
	Damper Time	150 seconds	Time allotted before damper fail is realized
	Runtest Time	76 seconds	
	Freeze Temp Low Limit	30°F	Temperature sensed by Freezestat which initiates compressor shutdown

APPENDIX 2: TEC-EYE ARCHITECTURE (CONT.)

Screen	Menu Item	Value	Description
	Reset Temperature	55°F	Temperature sensed by Freezestat which cancels compressor shutdown
	Reset Time	300 seconds	Time allotted which will also cancel compressor shutdown
	Blower Settings		
	Continuous	None	"Lead Only" or "Both" also available
	Blower Speeds		
	Heat	7.0V	Control voltage supplied from wall-mount unit control boards to blower in heat
	Econ	7.0V	Control voltage supplied from wall-mount unit control boards to blower in regular DC free cooling
	Econ Low Temp	3.8V	Control voltage supplied from wall-mount unit control boards to blower in low ambient condition DC free cooling
	Full Load	6.3V	Control voltage supplied from wall-mount unit control boards to blower in mechanical cooling
	Low Pressure Setup		
	Outside Setpoint	55°F	Temperature at which control separates two (2) different low pressure situations
	Differential	5°F	This differential applies to the outside setpoint
	Above Setpoint Delay	120 seconds	Any low pressure situation above the outside setpoint will be delayed 120 seconds before an alarm is initialized
	Below Setpoint Delay	180 seconds	Any low pressure situation below the outside setpoint will be delayed 180 seconds before an alarm is initialized
	Fieldbus Address	1	
	Compressor Timers		
	Minimum Off	120 seconds	Once stopped, the compressor remains inactive for this period of time
	Minimum On	300 seconds	Once started, the compressor remains on for this period of time
	Delay 2 Start	240 seconds	Startup delay on power cycle
	Compressor Stage Delay	60 seconds	Minimum run time for first stage of two-stage compressors
	Alarm Retry Setup		
	Low Pressure Retrys	3/60 minutes	Failures/amount of time before the system is locked-out in HVAC fail mode
	Set Disable	120 seconds	Amount of time switch is open before compressor is temporarily disabled in soft lockout
	Status	0/0 minutes	Recent amount of failures

Screen	Menu Item	Value	Description
	Clock/Scheduler		
	Date	(Current date)	
	Hour	(Current time)	
	Day	(Current day of week)	
	Clock		
	Daylight Savings Time	Enable	System clock will follow DST Protocol, "Disable" if desired
	Transition Time	60 minutes	
	Start	Last Sunday in March 2am	
	End	Last Sunday in Oct 3am	
	Inputs/Outputs		
	Analog Inputs		
	Supply Air Temp Input B001	(Current SAT)	
	Outdoor Air Temp Input B002	(current OAT)	
	Return Air Temp Input B003	(Current RAT)	
	Outdoor Humidity Input B005	(Current %RH)	
	Freezestat Input B007	(Current Freezestat temp)	
	Digital Inputs		
	Power Loss DI 1 Status	Closed	
	Filter Switch DI 2 Status	Closed	
	High Pressure Switch DI 3 Status	Closed	
	Low Pressure Switch DI4 Status	Closed	
	Blower DI 5 Status	Closed	
	Damper Switch DI 6 Status	Closed	
	Relay Outputs		
	Cooling Stage 1 Relay 2 Status	Off	
	Cooling Stage 2 Relay 3 Status	Off	
	Heating Relay 4 Status	Off	
	Blower Relay 7 Status	Off	
	Alarm History		
	Technician	(Use UP/DOWN arrow keys to scroll through latest alarms/conditions)	
	Information		
	Bard Code	Inside Controller	"Unit Controller" would be a pre-programmed wall-mount unit board
	Version	(Current Version)	
	Bios	(Current Bios)	
	Root	(Current Root)	
	Fishram	N/A	Internal memory specifications
	Power Cycle	N/A	Count of power initiations

APPENDIX 2: TEC-EYE ARCHITECTURE (CONT.)

Screen	Menu Item	Value	Description
	Working Hours		
	Compressor		
	Run Hours	0000h	Hours of operation
	Num Starts	00000S	Number of starts
	Compressor Full Load		
	Run Hours	0000h	Hours of operation
	Num Starts	00000S	Number of starts
	Free Cool		
	Run Hours	0000h	Hours of operation
	Num Starts	00000S	Number of starts
	Heat		
	Run Hours	0000h	Hours of operation
	Num Starts	00000S	Number of starts
	Blower		
	Run Hours	0000h	Hours of operation
	Num Starts	00000S	Number of starts
	Service Settings		
	Probe Adjustment		
	SAT Input B01		
	Offset	0	Calibrating sensor if necessary
	Value	(Current Temp)	Current temp plus offset
	OAT Input B02		
	Offset	0	Calibrating sensor if necessary
	Value	(Current Temp)	Current temp plus offset
	RAT Input B03		
	Offset	0	Calibrating sensor if necessary
	Value	(Current Temp)	Current temp plus offset
	Outdoor Air Humidity Input B05		
	Offset	0	Calibrating sensor if necessary
	Value	(Current %RH)	Current %RH plus offset
	Freezestat Input B07		
	Offset	0	Calibrating sensor if necessary
	Value	(Current Temp)	Current temp plus offset
	Control Loops		
	Modulating Damper Input	°F	Temperature at SAT
	Output	VDC	Output VDC to damper motor
	Setpoint	55°F	Loop modulates damper to achieve this temperature at SAT
	Band	5°F	Range of control
	Integration Time	120	
	Fail to Open Damper Delay	15 seconds	Amount of time before fail to open alarm is sent

Screen	Menu Item	Value	Description
	Fail to Close Damper Delay	240 seconds	Amount of time before fail to close alarm is sent
	Run Test Device Time	60 seconds	
	Enable	No	
	Manual Management		
	Analog Inputs		
	SAT Manual Control B001	Off	On to manually change temperature seen by controller
	Manual Position	0	Degrees of change in sensor for manual control
	Value	(Temp + Value)	Current temperature plus the value in manual position
	OAT Manual Control B002	Off	On to manually change temperature seen by controller
	Manual Position	0	Degrees of change in sensor for manual control
	Value	(Temp + Value)	Current temperature plus the value in manual position
	RAT Manual Control B003	Off	On to manually change temperature seen by controller
	Manual Position	0	Degrees of change in sensor for manual control
	Value	(Temp + Value)	Current temperature plus the value in manual position
	OAH Manual Control B005	Off	On to manually change temperature seen by controller
	Manual Position	0	Degrees of change in sensor for manual control
	Value	(% RH + Value)	Current %RH plus the value in manual position
	Freezestat Manual Control B007	Off	On to manually change temperature seen by controller
	Manual Position	0	Degrees of change in sensor for manual control
	Value	(Temp + Value)	Current temperature plus the value in manual position
	Digital Inputs		
	Power Loss Manual DI 1	Off	"On" to allow artificial manipulation power loss input
	Manual Position	Open/Closed	Change to "Open" to artifically create power loss input
	D1 Status	Closed	Current status of power loss input (closed means no input)
	Filter Switch Manual DI 2	Off	"On" to allow artificial manipulation filter switch input
	Manual Position	Open/Closed	Change to "Open" to artifically create filter switch input

APPENDIX 2: TEC-EYE ARCHITECTURE (CONT.)

Screen	Menu Item	Value	Description
	D2 Status	Closed	Current status of filter switch input (closed means no input)
	High Pressure DI 3	Off	"On" to allow artificial manipulation of high pressure switch input
	Manual Position	Open/Closed	Change to "Closed" to artificially create high pressure input
	D3 Status	Closed	Current status of high pressure input (open means no input)
	Low Pressure DI 4	Off	"On" to allow artificial manipulation of low pressure switch input
	Manual Position	Open/Closed	Change to "Closed" to artificially create low pressure input
	D3 Status	Closed	Current status of low pressure input (open means no input)
	Blower Status DI 5	Off	"On" to allow artificial manipulation of blower status input
	Manual Position	Open/Closed	Change to "Closed" to artificially create blower status input
	D3 Status	Closed	Current status of blower status input (open means no input)
	Damper Switch Status DI 6	Off	"On" to allow artificial manipulation of damper switch status input
	Manual Position	Open/Closed	Change to "Closed" to artificially create damper switch status input
	D3 Status	Closed	Current status of damper switch status input (open means no input)
	Relay Outputs		
	Cooling Stg 1 Manual Relay 2	Off	"On" to allow artificial manipulation of cooling stage 1 relay action
	Manual Position	On/Off	Change to "On" to artificially force cooling stage 1 relay
	Relay 2 Status	Off	Current status of cooling stage 1 relay (off means no relay action)
	Cooling Stg 2 Manual Relay 3	Off	"On" to allow artificial manipulation of cooling stage 2 relay action
	Manual Position	On/Off	Change to "On" to artificially force cooling stage 2 relay
	Relay 3 Status	Off	Current status of cooling stage 2 relay (off means no relay action)
	Heating Manual Relay 4	Off	"On" to allow artificial manipulation of heating relay action
	Manual Position	On/Off	Change to "On" to artificially force heating relay
	Relay 4 Status	Off	Current status of heating relay (off means no relay action)
	Blower Manual Relay 4	Off	"On" to allow artificial manipulation of blower relay action

Screen	Menu Item	Value	Description
	Manual Position	On/Off	Change to "On" to artificially force blower relay
	Relay 7 Status	Off	Current status of blower relay (off means no relay action)
	Factory		
	Configuration		
	Temperature Units	°F	°C units available as well
	Pressure Units	PSI	N/A
	Force Clock Enable	Yes	
	Clock Mode	24 hour	12 hour available
	Disable Buzzer	Yes	Audible buzzer available
	Startup Delay	1 second	
	Enable Unit	On/Off	
	by digit input	On	Allows unit control
	by supervisor	Off	N/A
	by pLAN network	Off	N/A
	by schedule	Off	N/A
	Analog Input Fitering		
	Enable	No	N/A
	Input 1	19 seconds	N/A
	Input 2	19 seconds	N/A
	Input 3	19 seconds	N/A
	Input 4	19 seconds	N/A
	Input 5	19 seconds	N/A
	I/O Configuration		
	Analog Inputs		
	Supply Air Temp Enable B001	On	
	Normal	Ohms x5	
	Min	0	
	Max	100	
	Offset	0	
	Value	°F	
	Input B001	°F	
	Power Delay	5 Seconds	
	Run Delay	5 Seconds	
	Units	Temperature	
	Outdoor Air Temp Enable B002	On	
	Normal	Ohms x5	
	Min	0	
	Max	100	
	Offset	0	

APPENDIX 2: TEC-EYE ARCHITECTURE (CONT.)

Screen	Menu Item	Value	Description
	Value	°F	
	Input B002	°F	
	Power Delay	5 Seconds	
	Run Delay	5 Seconds	
	Units	Temperature	
	Return Air Temp Enable B003	On	
	Normal	Ohms x5	
	Min	0	
	Max	100	
	Offset	0	
	Value	°F	
	Input B003	°F	
	Power Delay	5 seconds	
	Run Delay	5 seconds	
	Units	Temperature	
	Outdoor Air Hum. Enable B005	On	
	Normal	4-20mA	
	Min	0	
	Max	100	
	Offset	0	
	Value	% RH	
	Input B003	% RH	
	Power Delay	5 seconds	
	Run Delay	5 seconds	
	Units	(blank)	
	Freezestat Enable B003	On	
	Normal	Ohms x5	
	Min	0	
	Max	100	
	Offset	0	
	Value	°F	
	Input B003	°F	
	Power Delay	5 seconds	
	Run Delay	5 seconds	
	Units	Pressure	
	Analog Outputs		
	Blower Motor Enable	Yes	
	Channel	1	
	Action	Direct	
	Min	0.00V	
	Max	10.00V	

Screen	Menu Item	Value	Description
	Damper Enable	Yes	
	Channel	2	
	Action	Direct	
	Min	2.00V	
	Max	10.00V	
	Factory Settings		
	Damper Daily Test Enable	Yes	Midnight cycle damper test
	Voltage	2.5VDC	25% opening
	Blower Status Switch		
	Minimum Off	45 seconds	Allows motor to come to full stop before re-engaging
	Unit Controller		
	Serial Number		Wall-mount unit serial number
	Model Number		Wall-mount unit model number
	Factory Save		
	Save?	No	
	Restore?	No	
	Auto Restore?		
	User Save		
	Save?	No	
	Restore?	No	
	Auto Save?	Yes	
	Factory Delete		
	Clear ALL DATA	No	
	Passwords		
	User	0000	
	Tech	0000	
	Factory	0000	