INSTALLATION INSTRUCTIONS

WALL MOUNTED PACKAGE HEAT PUMP

Models:

W18HA-A	W24HA-A	W42HA-A	W24HADA	W42HADA
	W24HA-B	W42HA-B	W24HADB	W42HADB
	W24HA-C	W42HA-C	W24HADC	W42HADC
	W30HA-A	W48HA-A	W30HADA	W48HADA
	W30HA-B	W48HA-B	W30HADB	W48HADB
	W30HA-C	W48HA-C	W30HADC	W48HADC
	W36HA-A	W60HA-A	W36HADA	W60HADA
	W36HA-B	W60HA-B	W36HADB	W60HADB
	W36HA-C	W60HA-C	W36HADC	W60HADC



Climate Control Solutions

Bard Manufacturing Company, Inc.
Bryan, Ohio 43506
www.bardhvac.com

Manual: 2100-654A
Supersedes: 2100-654
Date: 2-16-16

CONTENTS

Getting Other Information and Publications 3

Wall Mount General Information 4

Heat Pump Wall Mount Model Nomenclature	4
Shipping Damage	4
General	4
Duct Work	4
Filters	5
Fresh Air Intake	5
Condensate Drain	5

Installation 6

Wall Mounting Information	6
Mounting the Unit	6
Clearances Required	6
Minimum Clearances	6
Wiring – Main Power	15
Wiring – Low Voltage Wiring	15

Figures

Figure 1 Fresh Air Damper	5
Figure 2 Unit Dimensions	7
Figure 3A Mounting Instructions – W18H, W24H....	8
Figure 3B Mounting Instructions – W30H, W36H....	9
Figure 3C Mounting Instructions – W42H, W48H..	10
Figure 3D Mounting Instructions – W60H.....	11
Figure 4 Electric Heat Clearance	12
Figure 5 Wall Mounting Instructions	13
Figure 6 Wall Mounting Instructions	13
Figure 7 Common Wall Mounting Installations	14
Figure 8 Programmable Thermostat Connections .	17
Figure 9 Non-Programmable Thermostat Connections	18
Figure 10 Defrost Control Board	18
Figure 11 Fan Blade Setting	21

Start Up 19

General	19
Topping Off System Charge	19
Safety Practices	19
Important Installer Note.....	20
High and Low Pressure Switch.....	20
Three Phase Scroll Compressor Start Up Information.....	20
Phase Monitor.....	20
Condenser Fan Operation	20
Service Hints	20
Vent Connection Plug.....	20
Sequence of Operation.....	21
Pressure Service Ports	21
Defrost Cycle	21

Service 24

Solid State Heat Pump Control Troubleshooting Procedure	24
Checking Temperature Sensor Outside Unit Circuit.....	25
Fan Blade Setting Dimensions	26
Removal of Fan Shroud.....	26
R-410A Refrigerant Charge	26

Tables

Table 1 Wall Thermostats	16
Table 2 Humidity Controls	16
Table 3 CO ₂ Controller.....	16
Table 4 Thermostat Wire Size.....	16
Table 5 Troubleshooting	24
Temperature vs. Resistance.....	25
Table 6 Fan Blade Dimension	26
Table 7A Cooling Pressure	27
Table 7B Heating Pressure.....	27
Table 8 Electrical Specifications	28
Table 9 Recommended Airflow	25
Table 10 Indoor Blower Performance	25
Table 11 Maximum ESP of Operation Electric Heat Only Tables.....	30
Table 12 Electric Heat	30
Table 13 Optional Accessories	31
Table 14 Vent and Control Options	32

GETTING OTHER INFORMATION AND PUBLICATIONS

These publications can help when installing the furnace. They can usually be found at the local library or purchased directly from the publisher. Be sure to consult the current edition of each standard.

National Electrical Code ANSI/NFPA 70

Standard for the Installation ANSI/NFPA 90A
of Air Conditioning and Ventilating Systems

Standard for Warm Air ANSI/NFPA 90B
Heating and Air Conditioning Systems

Load Calculation for ACCA Manual J
Residential Winter and Summer Air Conditioning

Duct Design for Residential ACCA Manual D
Winter and Summer Air Conditioning and Equipment
Selection

For more information, contact these publishers:

ACCA **Air Conditioning Contractors of America**
1712 New Hampshire Ave. N.W.
Washington, DC 20009
Telephone: (202) 483-9370
Fax: (202) 234-4721

ANSI **American National Standards Institute**
11 West Street, 13th Floor
New York, NY 10036
Telephone: (212) 642-4900
Fax: (212) 302-1286

ASHRAE **American Society of Heating, Refrigeration
and Air Conditioning Engineers, Inc.**
1791 Tullie Circle, N.E.
Atlanta, GA 30329-2305
Telephone: (404) 636-8400
Fax: (404) 321-5478

NFPA **National Fire Protection Association**
Batterymarch Park
P.O. Box 9101
Quincy, MA 02269-9901
Telephone: (800) 344-3555
Fax: (617) 984-7057

WALL MOUNT GENERAL INFORMATION

HEAT PUMP WALL MOUNT MODEL NOMENCLATURE

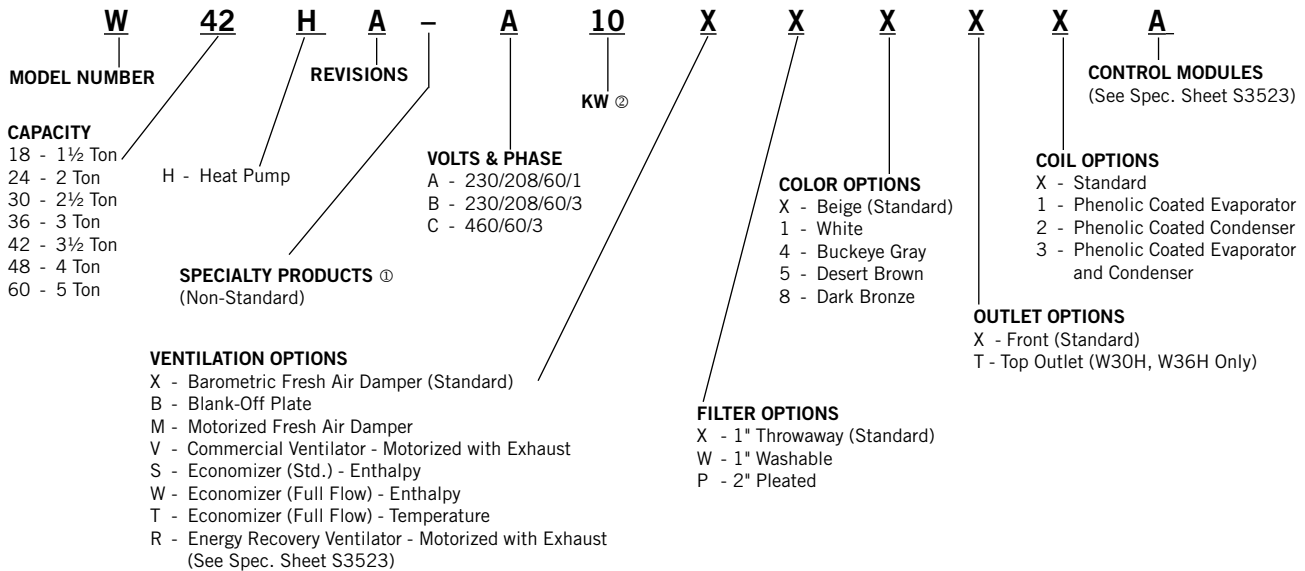

① Insert "D" for dehumidification with hot gas reheat. Reference Form 7960-702 for complete details.

② For 0 KW and circuit breakers (230/208 volt) or toggle disconnect (460V) applications, insert OZ in the KW field of the model number.

NOTE: Vent options X, B and M are without exhaust capability. May require separate field-supplied barometric relief in building.

SHIPPING DAMAGE

Upon receipt of equipment, the carton should be checked for external signs of shipping damage. If damage is found, the receiving party must contact the last carrier immediately, preferably in writing, requesting inspection by the carrier's agent.

GENERAL

The equipment covered in this manual is to be installed by trained, experienced service and installation technicians.

The refrigerant system is completely assembled and charged. All internal wiring is complete.

The unit is designed for use with or without duct work. Flanges are provided for attaching the supply and return ducts.

These instructions explain the recommended method to install the air cooled self-contained unit and the electrical wiring connections to the unit.

These instructions and any instructions packaged with any separate equipment required to make up the entire air conditioning system should be carefully read before beginning the installation. Note particularly "Starting Procedure" and any tags and/or labels attached to the equipment.

While these instructions are intended as a general recommended guide, they do not supersede any national and/or local codes in any way. Authorities having jurisdiction should be consulted before the installation is made. See page 3 for information on codes and standards.

Size of unit for a proposed installation should be based on heat loss/gain calculation made according to methods of Air Conditioning Contractors of America (ACCA). The air duct should be installed in accordance with the Standards of the National Fire Protection Association for the Installation of Air Conditioning and Ventilating Systems of Other Than Residence Type, NFPA No. 90A, and Residence Type Warm Air Heating and Air Conditioning Systems, NFPA No. 90B. Where local regulations are at a variance with instructions, installer should adhere to local codes.

DUCT WORK

All duct work, supply and return, must be properly sized for the design airflow requirement of the equipment. Air Conditioning Contractors of America (ACCA) is an excellent guide to proper sizing. All duct work or portions thereof not in the conditioned space should be properly insulated in order to both conserve energy and prevent condensation or moisture damage.

Refer to Maximum ESP of Operation Electric Heat Table 7 on page 30.

Design the duct work according to methods given by the Air Conditioning Contractors of America (ACCA). When duct runs through unheated spaces, it should be insulated with a minimum of 1" of insulation. Use insulation with a vapor barrier on the outside of the insulation. Flexible joints should be used to connect the duct work to the equipment in order to keep the noise transmission to a minimum.

Models W18 and W24 are approved for 0" clearance to the supply duct. For models W30, W36, W42, W48 and W60, a 1/4" clearance to combustible material for the first 3' of duct attached to the outlet air frame is required. See **Mounting the Unit** on page 6 and Figures 3A-D (pages 8-11) and Figure 4 (page 12) for further details.

Ducts through the walls must be insulated and all joints taped or sealed to prevent air or moisture entering the wall cavity.

Some installations may not require any return air duct. A metallic return air grille is required with installations not requiring a return air duct. The spacing between louvers on the grille shall not be larger than 5/8".

Any grille that meets with 5/8" louver criteria may be used. It is recommended that Bard Return Air Grille Kit RG-2W through RG-5W or RFG-2W through RFG-5W be installed when no return duct is used. Contact distributor or factory for ordering information. If using a return air filter grille, filters must be of sufficient size to allow a maximum velocity of 400 fpm.

NOTE: *If no return air duct is used, applicable installation codes may limit this cabinet to installation only in a single story structure.*

FILTERS

A 1" throwaway filter is standard with each unit. The filter slides into position making it easy to service. This filter can be serviced from the outside by removing the filter access panel. A 1" washable filter and 2" pleated filter are also available as optional accessories. The internal filter brackets are adjustable to accommodate the 2" filter by bending two tabs down on each side of the filter support bracket.

FRESH AIR INTAKE

All units are built with fresh air inlet slots punched in the service door.

If the unit is equipped with a fresh air damper assembly, the assembly is shipped already attached to the unit. The damper blade is locked in the closed position. To allow the damper to operate, the maximum and minimum blade position stops must be installed (see Figure 1).

All capacity, efficiency and cost of operation information is based upon the fresh air blank-off plate in place and is recommended for maximum energy efficiency.

The blank-off plate is available upon request from the factory and is installed in place of the fresh air damper shipped with each unit.

CONDENSATE DRAIN

A plastic drain hose extends from the drain pan at the top of the unit down to the unit base. There are openings in the unit base for the drain hose to pass through. In the event the drain hose is connected to a drain system of some type, it must be an open or vented type system to assure proper drainage.

FIGURE 1
Fresh Air Damper

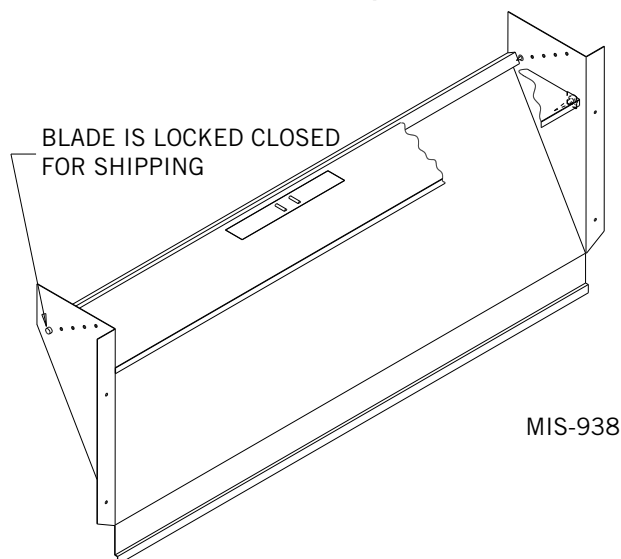

INSTALLATION

WALL MOUNTING INFORMATION

1. Two holes for the supply and return air openings must be cut through the wall as shown in Figure 3.
2. On wood frame walls, the wall construction must be strong and rigid enough to carry the weight of the unit without transmitting any unit vibration.
3. Concrete block walls must be thoroughly inspected to insure that they are capable of carrying the weight of the installed unit.

NOTE: Before mounting the heat pump unit, consideration should be given to the condensate removal from the outdoor coil when in heating mode. The unit must be mounted high enough above grade to ensure that ice will not build up under the unit and come into contact with the base of the unit. If allowed, this could cause damage to the coil and other base components. Also, be sure there are no air obstructions to the sides or front of the unit, such as bushes or fences, that would inhibit condenser airflow.

MOUNTING THE UNIT

1. These units are secured by wall mounting brackets which secure the unit to the outside wall surface at both sides. A bottom mounting bracket, attached to skid for shipping, is provided for ease of installation, but is not required.
2. The unit itself is suitable for 0" clearance, but the supply air duct flange and the first 3' of supply air duct require a minimum of 1/4" clearance to combustible material for model series W30, W36, W42, W48 and W60. However, it is generally recommended that a 1" clearance is used for ease of installation and maintaining the required clearance to combustible material. See Figures 3A-D for details on opening sizes.

WARNING

Failure to provide the 1/4" clearance between the supply duct and a combustible surface for the first 3' of duct can result in fire causing damage, injury or death.

Minimum Clearances Required to Combustible Materials

MODELS	SUPPLY AIR DUCT FIRST 3'	CABINET
W18H/W24H	0"	0"
W30H/W36H	1/4"	0"
W42H/W48H/W60H	1/4"	0"

Clearances Required for Service Access and Adequate Condenser Airflow

MODELS	LEFT SIDE	RIGHT SIDE
W18H, W24H, W30H, W36H	15"	20"
W42H, W48H, W60H	20"	20"

3. Locate and mark lag bolt locations and bottom mounting bracket location (see Figures 3A-D).
4. Mount bottom mounting bracket.
5. Hook top rain flashing, attached to front - right of supply flange for shipping, under back bend of top.
6. Position unit in opening and secure with fasteners sufficient for the application such as 5/16" lag/anchor/carriage bolts; use 7/8" diameter flat washers on the bolts.
7. Secure rain flashing to wall and caulk across entire length of top (see Figures 3A-D).
8. For additional mounting rigidity, the return air and supply air frames or collars can be drilled and screwed or welded to the structural wall itself (depending upon wall construction). Be sure to observe required clearance if combustible wall.
9. On side-by-side installations, maintain a minimum of 20" clearance on right side to allow access to control panel and heat strips, and to allow proper airflow to the outdoor coil. Additional clearance may be required to meet local or national codes.

NOTE: Refer to Figures 2 – 7 for dimensions and various mounting configurations.

FIGURE 2

Dimensions of Basic Unit for Architectural and Installation Requirements (Nominal)

MODEL	WIDTH (W)	DEPTH (D)	HEIGHT (H)	SUPPLY		RETURN																
				A	B	C	B	E	F	G	I	J	K	L	M	N	O	P	Q	R	S	T
W18HA W24HA	33.300	17.125	74.563	7.88	19.88	11.88	19.88	35.00	10.88	29.75	20.56	30.75	32.06	33.25	31.00	2.63	34.13	26.06	10.55	4.19	12.00	9.00
W30HA W36HA	38.200	17.125	74.563	7.88	27.88	13.88	27.88	40.00	10.88	29.75	17.93	30.75	32.75	33.25	31.00	2.75	39.13	26.75	9.14	4.19	12.00	9.00
W42HA W48HA	42.075	22.432	84.875	9.88	29.88	15.88	29.88	43.88	13.56	31.66	30.00	32.68	26.94	34.69	32.43	3.37	43.00	23.88	10.00	1.44	16.00	1.88
W60HA	42.075	22.432	93.000	9.88	29.88	15.88	29.88	43.88	13.56	37.00	30.00	40.81	35.06	42.81	40.56	3.37	43.00	31.00	10.00	1.44	16.00	10.00

All dimensions are in inches. Dimensional drawings are not to scale.

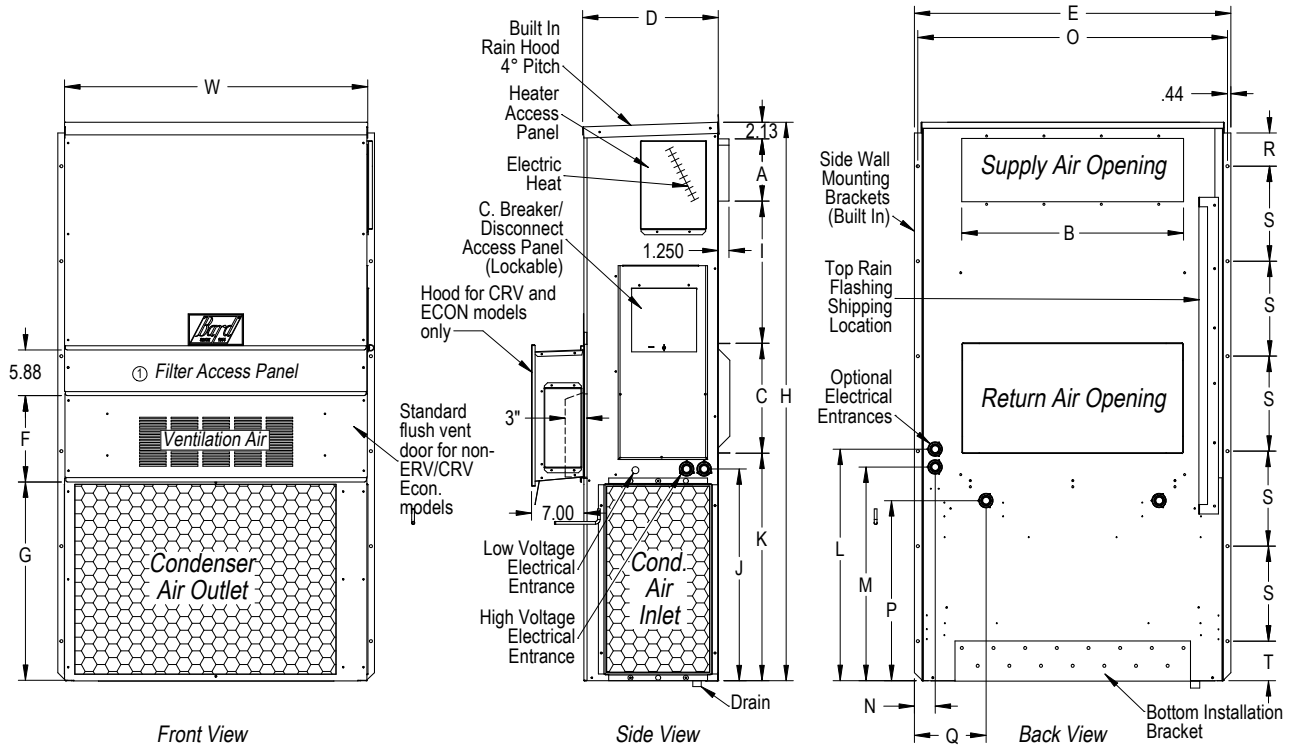

MS-3796

FIGURE 3B
W30H, W36H
Mounting Instructions

	A	B	C	D	E
REQUIRED DIMENSIONS TO MAINTAIN 1/4" MIN. CLEARANCE FROM COMBUSTIBLE MATERIALS	28 3/8	8 3/8	5 3/8	3 11/16	17 5/8
REQUIRED DIMENSIONS TO MAINTAIN RECOMMENDED 1" CLEARANCE FROM COMBUSTIBLE MATERIALS	29 7/8	9 7/8	4 5/8	4 7/16	16 7/8

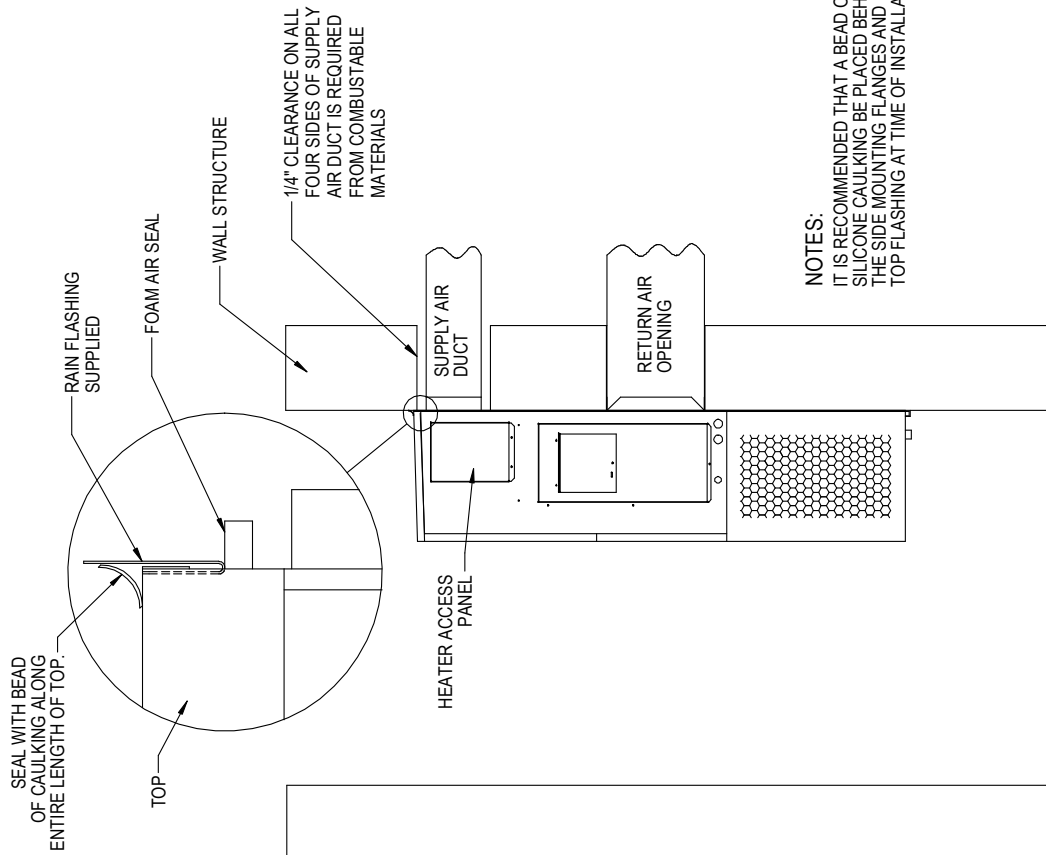

NOTES:
 IT IS RECOMMENDED THAT A BEAD OF SILICONE CAULKING BE PLACED BEHIND THE SIDE MOUNTING FLANGES AND UNDER TOP FLASHING AT TIME OF INSTALLATION.

Right Side View

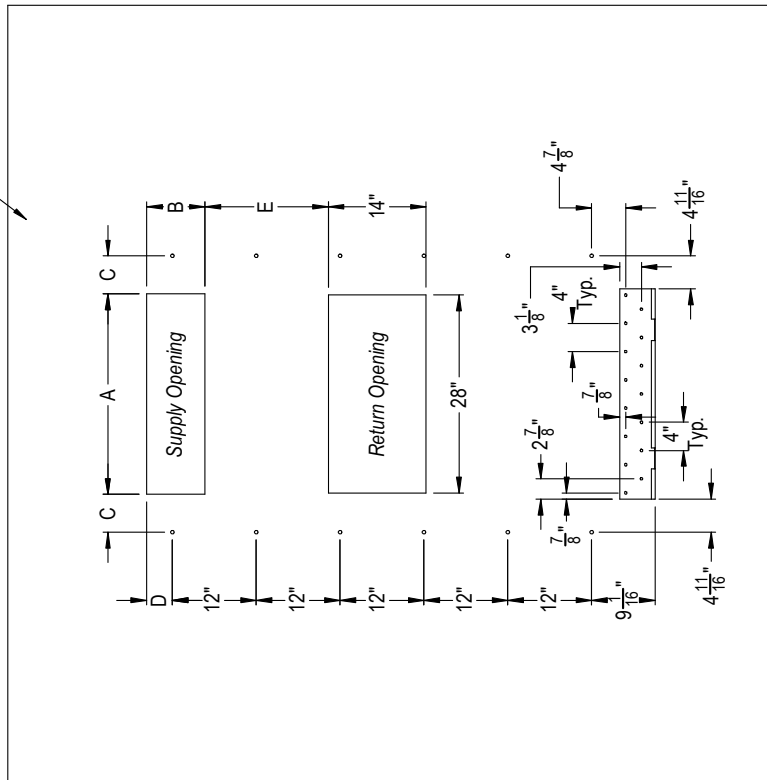

Wall Opening and Hole Location View

MIS-3158 A

FIGURE 3C
W42H, W48H
Mounting Instructions

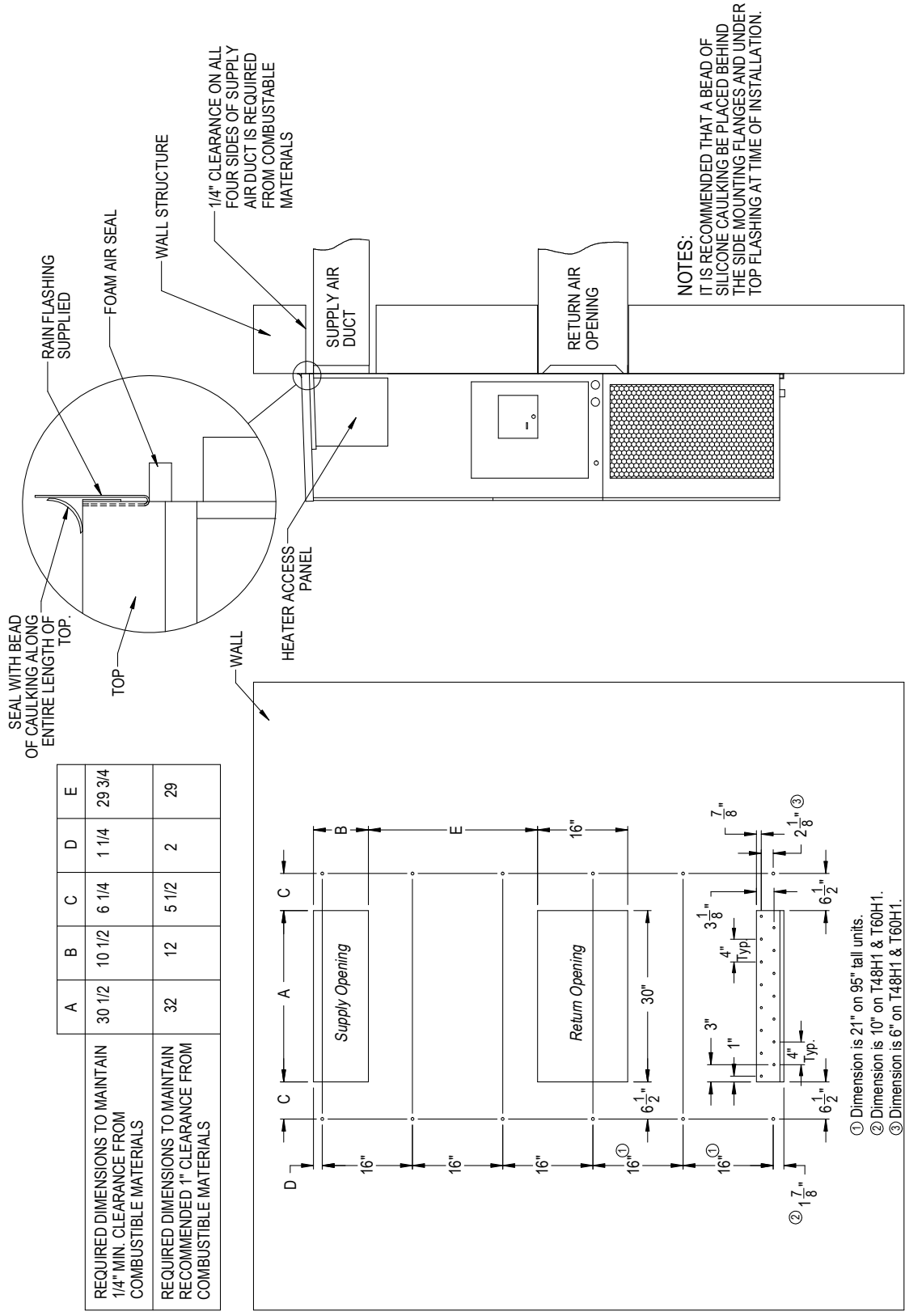

	A	B	C	D	E
REQUIRED DIMENSIONS TO MAINTAIN 1/4" MIN. CLEARANCE FROM COMBUSTIBLE MATERIALS	30 1/2	10 1/2	6 1/4	1 1/4	29 3/4
REQUIRED DIMENSIONS TO MAINTAIN RECOMMENDED 1" CLEARANCE FROM COMBUSTIBLE MATERIALS	32	12	5 1/2	2	29

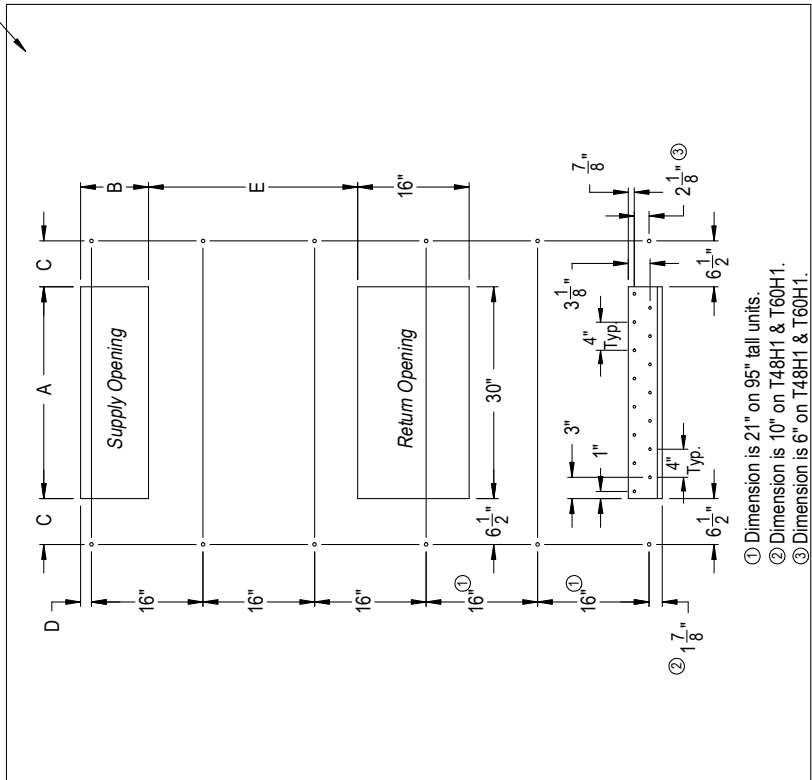

Right Side View

Wall Opening and Hole Location View

FIGURE 4
Electric Heat Clearance
W30H, W36H, W42H, W48H, W60H

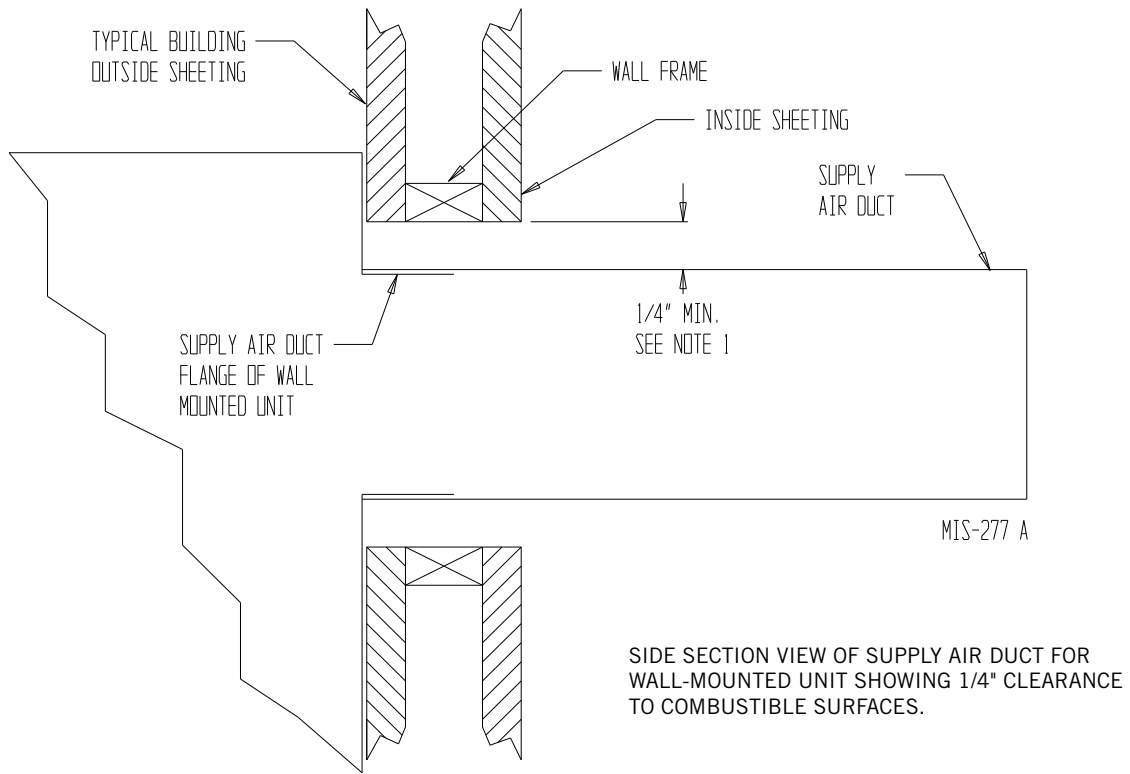

WARNING

A **minimum** of 1/4" clearance must be maintained between the supply air duct and combustible materials. This is required for the first 3' of ducting.

It is important to insure that the 1/4" minimum spacing is maintained at all points.

Failure to do this could result in overheating the combustible material and may result in a fire causing damage, injury or death.

FIGURE 5
Wall Mounting Instructions

SEE FIGURES 3A-D – MOUNTING INSTRUCTIONS

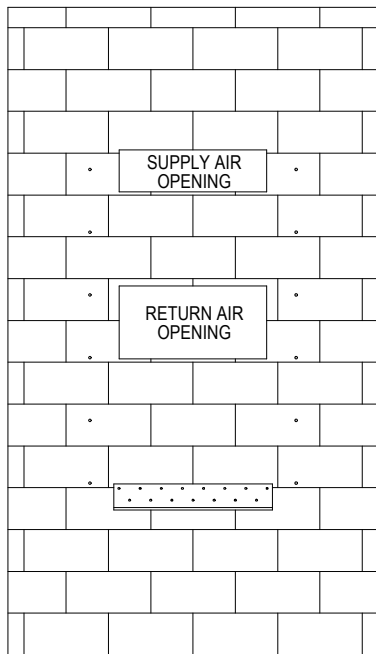

CONCRETE BLOCK WALL INSTALLATION

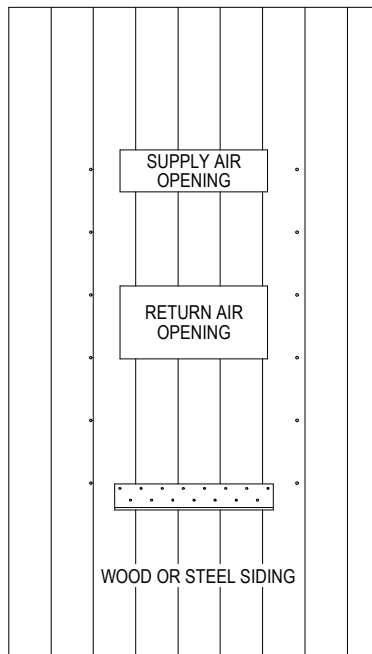

WOOD FRAME WALL INSTALLATION

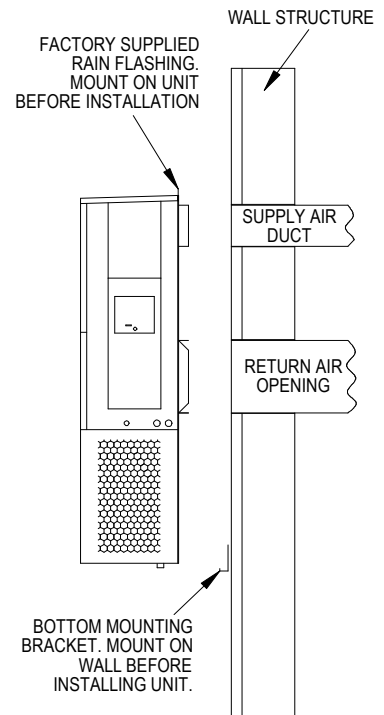

SIDE VIEW

MIS-548 A

FIGURE 6
Wall Mounting Instructions

SEE UNIT DIMENSIONS, FIGURE 2,
FOR ACTUAL DIMENSIONS.

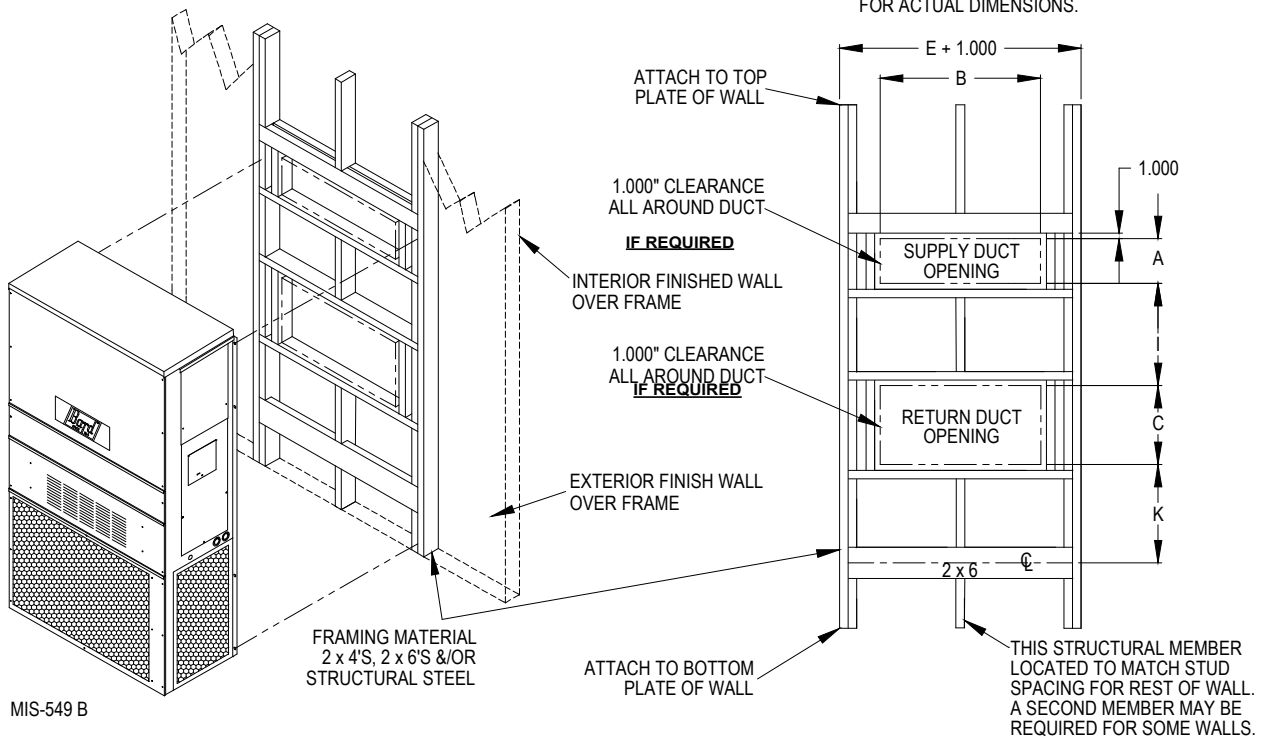

MIS-549 B

FIGURE 7
Common Wall Mounting Installations

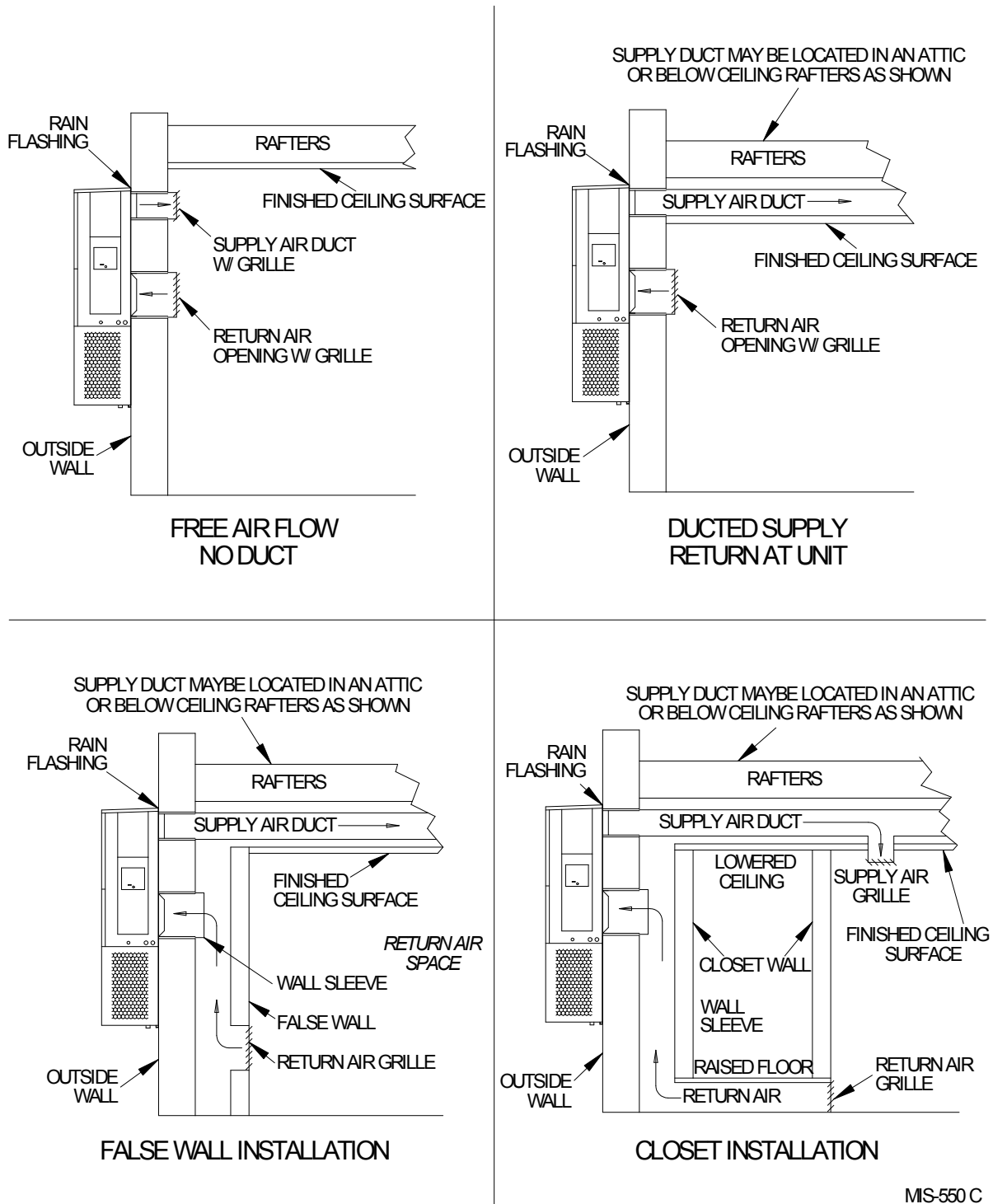

MIS-550 C

WIRING – MAIN POWER

Refer to the unit rating plate for wire sizing information and maximum fuse or circuit breaker size. Each outdoor unit is marked with a “Minimum Circuit Ampacity”. This means that the field wiring used must be sized to carry that amount of current. Depending on the installed KW of electric heat, there may be two field power circuits required. If this is the case, the unit serial plate will so indicate. All models are suitable only for connection with copper wire. Each unit and/or wiring diagram will be marked “Use Copper Conductors Only”. These instructions **must be** adhered to. Refer to the National Electrical Code (NEC) for complete current carrying capacity data on the various insulation grades of wiring material. All wiring must conform to NEC and all local codes.

The electrical data lists fuse and wire sizes (75°C copper) for all models including the most commonly used heater sizes. Also shown are the number of field power circuits required for the various models with heaters.

The unit rating plate lists a maximum fuse or circuit breaker that is to be used with the equipment. The correct size must be used for proper circuit protection and also to assure that there will be no nuisance tripping due to the momentary high starting current of the compressor motor.

The disconnect access door on this unit may be locked to prevent unauthorized access to the disconnect. To convert for the locking capability, bend the tab located in the bottom left-hand corner of the disconnect opening under the disconnect access panel straight out. This tab will now line up with the slot in the door. When shut, a padlock may be placed through the hole in the tab preventing entry.

See page 19 for important information on three phase scroll compressor start ups.

See Table 8 on page 28 for electrical specifications.

WIRING – LOW VOLTAGE WIRING

All 230/208V 1 phase and 3 phase equipment have dual primary voltage transformers. All equipment leaves the factory wired on 240V tap. For 208V operation, reconnect from 240V to 208V tap. The acceptable operating voltage range for the 240 and 208V taps are:

TAP	RANGE
240	253 – 216
208	220 – 187

NOTE: *The voltage should be measured at the field power connection point in the unit and while the unit is operating at full load (maximum amperage operating condition).*

For low voltage wiring, an 18 gauge copper, color-coded cable is recommended. See Table 4 on page 16 for more information.

Low Voltage Connections

These units use a 24-volt AC low voltage circuit. The “RT” terminal is the 24V transformer output, and the “R” terminal is the 24VAC *hot* terminal for the operation of the equipment. “RT” and “R” are connected with brass jumper bar which can be removed and “RT” and “R” connected to external NC (normally closed) contact such as a fire/smoke detector that will cause immediate shutdown of the equipment upon activation.

“C” terminal is 24VAC common and is grounded.

“G” terminal is the fan input.

“Y1” terminal is the 1st Stage input for cooling.

“Y2” terminal is the 2nd Stage compressor input for cooling (if equipped with an economizer).

“B/W1” terminal is the reversing valve input. The reversing valve must be energized for heating mode.

“W2” terminal is the 2nd stage heat (if equipped).

“W3” terminal is the emergency heat input. This terminal energizes the emergency heat relay.

“A” terminal is the ventilation input. This terminal energizes any factory-installed ventilation option and indoor blower.

“D” terminal is the dehumidification input. If installed, this terminal energizes any factory-installed dehumidification option.

“L/1” terminal is the compressor lockout output. This terminal is activated on a high or low pressure trip by the electronic heat pump control. This is a 24VAC output.

LOW VOLTAGE CONNECTIONS FOR DDC CONTROL		
	Standard Units	Units w/ Economizers
Fan Only	Energize G	Energize G
1st Stage Cooling Mode	Energize Y1, G	Energize Y1, G
2nd Stage Cooling Mode		Energize Y1, Y2, G
Heat Pump Heating	Energize Y1, G, B/W1	Energize Y1, G, B/W1
2nd Stage Heating w/heat pump (if employed)	Energize Y1, G, B/W1, W2	Energize Y1, G, B/W1, W2
Ventilation	Energize A	Energize A
Dehumidification (if employed)	Energize D	Energize D
Emergency Heat	Energize W3	Energize W3

**TABLE 1
Wall Thermostats**

Part Number	Predominate Features
8403-057 (TH3110D1040)	1 stage Cool, 1 stage Heat; Electronic Non-Programmable; Auto or Manual changeover
8403-058 (TH5220D1151)	2 stage Cool, 2 stage Heat; Electronic Non-Programmable; HP or Conventional (Default: HP); Auto or Manual changeover
8403-059 (TH5220D1219/U)	2 stage Cool, 2 stage Heat; Electronic Non-Programmable; HP or Conventional (Default: AC); Auto or Manual changeover
8403-060 (1120-445)	3 stage Cool; 3 stage Heat; Electronic Programmable/Non-Programmable; HP or Conventional; Auto or Manual changeover; Dehumidification Output
CS9B-THO	3 Stage Heat, 3 Stage Cool; Programmable/Non-Programmable; HP or Conventional; Auto or Manual Changeover; Humidity Sensor w/dehumidification; Motion Sensor w/Intelligent Learning Control; BACnet-compatible
CS9B-THOC	3 Stage Heat, 3 Stage Cool, Programmable/Non-Programmable; HP or Conventional; Auto or Manual Changeover; Humidity Sensor w/dehumidification; CO ₂ Sensor; Motion Sensor w/Intelligent Learning Control; BACnet-compatible
CS9BE-THO	3 Stage Heat, 3 Stage Cool, Programmable/Non-Programmable; HP or Conventional; Auto or Manual Changeover; Humidity Sensor w/dehumidification; Motion Sensor w/Intelligent Learning Control; BACnet-compatible; Ethernet-compatible
CS9BE-THOC	3 Stage Heat, 3 Stage Cool, Programmable/Non-Programmable; HP or Conventional; Auto or Manual Changeover; Humidity Sensor w/dehumidification; CO ₂ Sensor; Motion Sensor w/Intelligent Learning Control; BACnet-compatible; Ethernet-compatible

**TABLE 2
Humidity Controls**

Part Number	Predominate Features
8403-038 (H600A1014)	SPDT switching, pilot duty 50VA @ 24V Humidity range 20-80% RH
8403-047 (H200-10-21-10)	Electronic dehumidstat SPST closes-on-rise Humidity range 10-90% with adjustable stops

**TABLE 3
CO₂ Controller**

Part Number	Predominate Features
8403-067	Normally Open SPST relay closes-on-rise 24V dual wave length sensor. Default setting 950ppm, adjustable to 0-2000ppm Default off setting 1000ppm, adjustable to 0-200 ppm can be calibrated

**TABLE 4
Thermostat Wire Size**

Transformer VA	FLA	Wire Gauge	Maximum Distance In Feet
55	2.3	20 gauge	45
		18 gauge	60
		16 gauge	100
		14 gauge	160
		12 gauge	250

FIGURE 8
Programmable Thermostat Connections

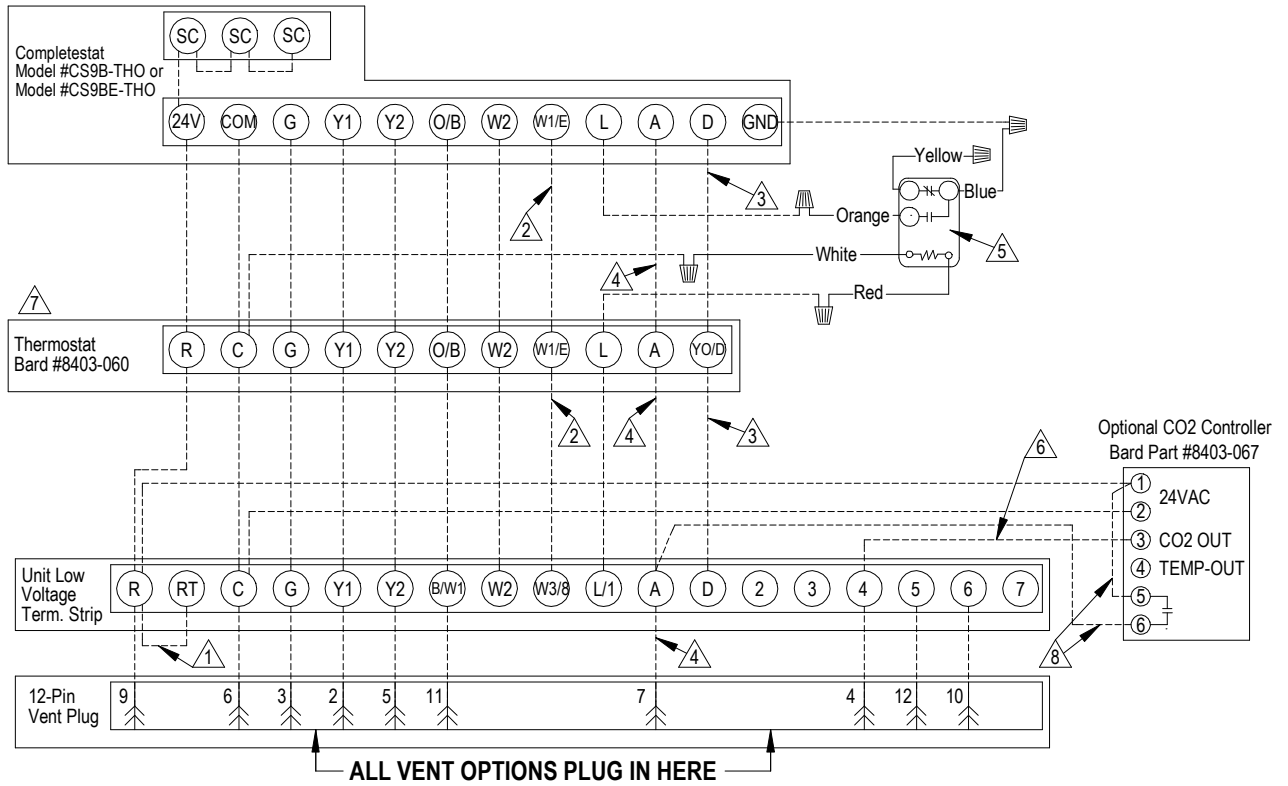

If not equipped with a ventilation option to plug in, a jumper plug must be installed.

- | | |
|--|--|
| <p>⚠️ 1 Factory installed jumper. Remove jumper and connect to N.C fire alarm circuit if emergency shutdown required.</p> <p>⚠️ 2 Wire not needed below 15KW.</p> <p>⚠️ 3 Wire required for dehumidification models only.</p> <p>⚠️ 4 Do not connect "A" from thermostat if optional CO2 controller is used</p> <p>⚠️ 5 Relay Provided with Completestat</p> | <p>⚠️ 6 0-10 VDC modulating CO2 control signal for modulating ventilation control (optional for ECON only - see vent instruction manuals)
Change model configuration from heat pump to heat/cool. Must be configured to programmable and fan set to be programmed fan for the "A" output to function during scheduled occupied periods. Must be configured for multi-stage for Y1 output to be active 1st stage cooling. For dehumidification, must be configured for "No Economizer" for YO/D to be active for humidity control.</p> <p>⚠️ 8 Do not add these wires if setting up for modulating control. See note 7.</p> |
|--|--|

MIS-3821

FIGURE 9
Non-Programmable Thermostat Connections

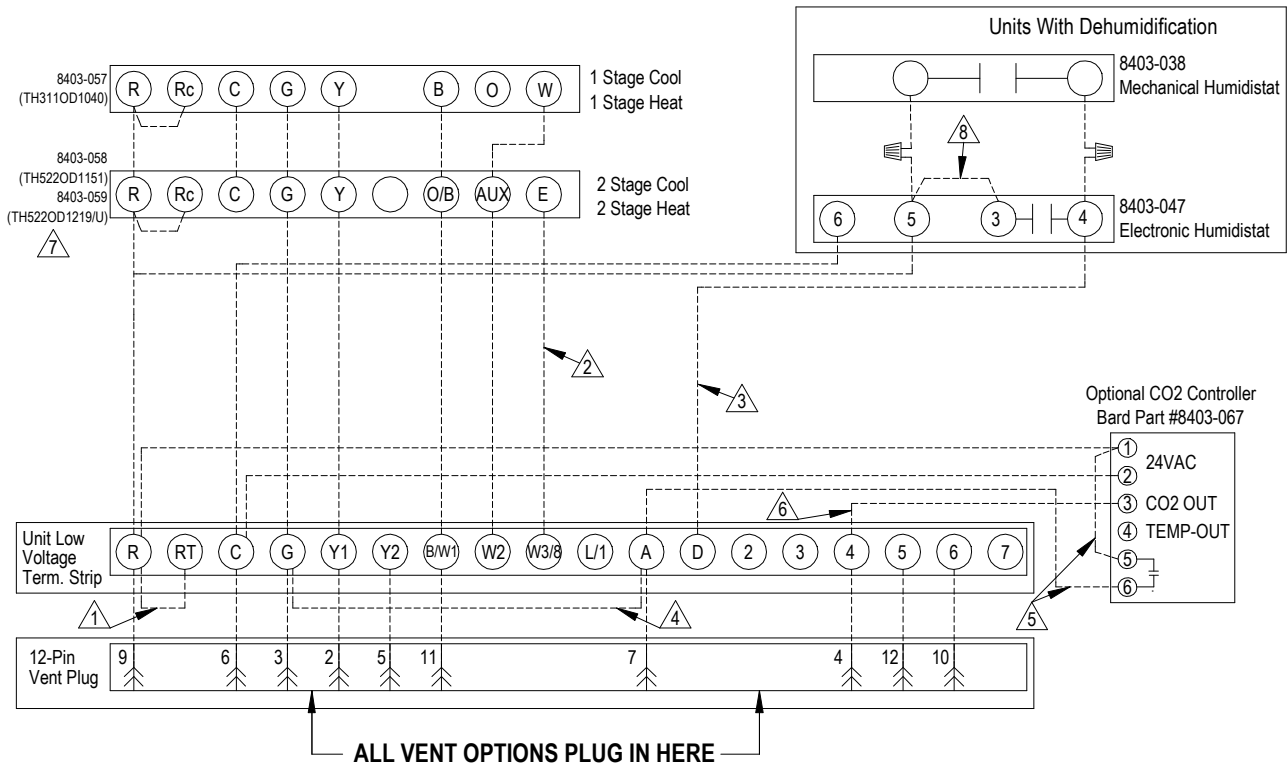

If not equipped with a ventilation option to plug in, a jumper plug must be installed.

- | | |
|---|--|
| <p>⚠ 1 Factory installed jumper. Remove jumper and connect to N.C fire alarm circuit if emergency shutdown required.</p> <p>⚠ 2 Wire not needed below 15KW.</p> <p>⚠ 3 Wire required for dehumidification models only.</p> <p>⚠ 4 For vent operation, add jumper if optional CO2 controller is not used. Vent will run while blower is energized.</p> | <p>⚠ 5 Do not add these wires if setting up for modulating control. See note 7.</p> <p>⚠ 6 0-10 VDC Modulating CO2 control signal for modulating ventilation control (Optional for ECON Only) - See vent installation manual.</p> <p>⚠ 7 For 8403-059, change "system type", set up Function 1, From 6 (2 Heat/ 1 Cool) to 5 (2 Heat / 1 Cool Heat pump). For 8403-058, No change required.</p> <p>⚠ 8 Jumper needs added.</p> |
|---|--|

MIS-3822

THESE UNITS REQUIRE R-410A REFRIGERANT AND POLYOL ESTER OIL.**GENERAL**

1. Use separate service equipment to avoid cross contamination of oil and refrigerants.
2. Use recovery equipment rated for R-410A refrigerant.
3. Use manifold gauges rated for R-410A (800 psi/250 psi low).
4. R-410A is a binary blend of HFC-32 and HFC-125.
5. R-410A is nearly azeotropic—similar to R-22 and R-12. Although nearly azeotropic, charge with liquid refrigerant.
6. R-410A operates at 40-70% higher pressure than R-22 and systems designed for R-22 cannot withstand this higher pressure.
7. R-410A has an ozone depletion potential of zero, but must be reclaimed due to its global warming potential.
8. R-410A compressors use Polyol Ester oil.
9. Polyol Ester oil is hygroscopic; it will rapidly absorb moisture and strongly hold this moisture in the oil.
10. A liquid line dryer must be used—even a deep vacuum will not separate moisture from the oil.
11. Limit atmospheric exposure to 15 minutes.
12. If compressor removal is necessary, always plug compressor immediately after removal. Purge with small amount of nitrogen when inserting plugs.

TOPPING OFF SYSTEM CHARGE

If a leak has occurred in the system, Bard Manufacturing recommends reclaiming, evacuating (see criteria above) and charging to the nameplate charge. If done correctly, topping off the system charge can be done without problems.

With R-410A, there are no significant changes in the refrigerant composition during multiple leaks and recharges. R-410A refrigerant is close to being an azeotropic blend (it behaves like a pure compound or single component refrigerant). The remaining refrigerant charge, in the system, may be used after leaks have occurred and then “top-off” the charge by utilizing the pressure charts on the inner control panel cover as a guideline.

REMEMBER: When adding R-410A refrigerant, it must come out of the charging cylinder/tank as a liquid to avoid any fractionation, and to ensure optimal system performance. Refer to instructions for the cylinder that is being utilized for proper method of liquid extraction.

**WARNING**

Failure to conform to these practices could lead to damage, injury or death.

SAFETY PRACTICES

1. Never mix R-410A with other refrigerants.
2. Use gloves and safety glasses. Polyol Ester oils can be irritating to the skin, and liquid refrigerant will freeze the skin.
3. Never use air and R-410A to leak check; the mixture may become flammable.
4. Do not inhale R-410A—the vapor attacks the nervous system, creating dizziness, loss of coordination and slurred speech. Cardiac irregularities, unconsciousness and ultimately death can result from breathing this concentration.
5. Do not burn R-410A. This decomposition produces hazardous vapors. Evacuate the area if exposed.
6. Use only cylinders rated DOT4BA/4BW 400.
7. Never fill cylinders over 80% of total capacity.
8. Store cylinders in a cool area, out of direct sunlight.
9. Never heat cylinders above 125°F.
10. Never trap liquid R-410A in manifold sets, gauge lines or cylinders. R-410A expands significantly at warmer temperatures. Once a cylinder or line is full of liquid, any further rise in temperature will cause it to burst.

IMPORTANT INSTALLER NOTE

For improved start-up performance, wash the indoor coil with dishwashing detergent.

HIGH AND LOW PRESSURE SWITCH

All W**H Series wall-mounted heat pump models are supplied with a remote reset for the high and low pressure switch. If tripped, this pressure switch may be reset by turning the thermostat off then back on again.

THREE PHASE SCROLL COMPRESSOR START UP INFORMATION

Scroll compressors, like several other types of compressors, will only compress in one rotational direction. Direction of rotation is not an issue with single phase compressors since they will always start and run in the proper direction.

However, three phase compressors will rotate in either direction depending upon phasing of the power. Since there is a 50-50 chance of connecting power in such a way as to cause rotation in the reverse direction, verification of proper rotation must be made. Verification of proper rotation direction is made by observing that suction pressure drops and discharge pressure rises when the compressor is energized. Reverse rotation also results in an elevated sound level over that with correct rotation, as well as substantially reduced current draw compared to tabulated values.

Verification of *proper rotation* must be made at the time the equipment is put into service. If improper rotation is corrected at this time, there will be no negative impact on the durability of the compressor. However, reverse operation for over 1 hour may have a negative impact on the bearing due to oil pump out.

NOTE: *If compressor is allowed to run in reverse rotation for several minutes, the compressor's internal protector will trip.*

All three phase ZP compressors are wired identically internally. As a result, once the correct phasing is determined for a specific system or installation, connecting properly phased power leads to the same Fusite terminal should maintain proper rotation direction.

The direction of rotation of the compressor may be changed by reversing any two line connections to the unit.

PHASE MONITOR

All units with three phase scroll compressors are equipped with a three phase line monitor to prevent compressor damage due to phase reversal.

The phase monitor in this unit is equipped with two LEDs. If the Y signal is present at the phase monitor and phases are correct, the green LED will light.

If phases are reversed, the red fault LED will be lit and compressor operation is inhibited.

If a fault condition occurs, reverse two of the supply leads to the unit. **Do not reverse any of the unit factory wires as damage may occur.**

CONDENSER FAN OPERATION

Applies to W42, W48 and W60 models only. The condenser fan motor on 230/208 volt, one and three phase, 60 HZ units is a two-speed motor that comes factory wired on high speed for peak performance. If ambient conditions permit, it can be reconnected to low speed (red wire) for lower sound level (see unit wiring diagram).

50 HZ models must have fan wired on low speed. These models are factory wired on low speed.

SERVICE HINTS

1. Caution owner/operator to maintain clean air filters at all times and to not needlessly close off supply and return air registers. This reduces airflow through the system, which shortens equipment service life as well as increasing operating costs.
2. Check all power fuses or circuit breakers to be sure they are the correct rating.
3. Periodic cleaning of the outdoor coil to permit full and unrestricted airflow circulation is essential.

VENT CONNECTION PLUG

All units are equipped with a vent connection plug in the side of the control panel for the different ventilation packages to plug in to. If the compressor will not start and there is no "Y1" at the compressor control module, first check to make sure that either the optional vent is plugged into the vent connection plug or the supplied jumper plug is in place. **The unit will not operate without anything plugged in.** This plug is located on the side of the control panel behind the front vent door (behind the filter access door). If the unit is supplied with a factory-installed vent package, it will be plugged in but the jumper plug will also be tethered next to the connection for troubleshooting purposes, if necessary.

SEQUENCE OF OPERATION

COOLING – Circuit R-Y makes at thermostat pulling in compressor contactor, starting the compressor and outdoor motor. The G (indoor motor) circuit is automatically completed on any call for cooling operation or can be energized by manual fan switch on subbase for constant air circulation.

HEATING – A 24V solenoid coil on reversing valve controls heating cycle operation. Two thermostat options, one allowing “Auto” changeover from cycle to cycle and the other constantly energizing solenoid coil during heating season, thus eliminating pressure equalization noise except during defrost, are to be used. On “Auto” option a circuit is completed from R-B/W1 and R-Y on each heating “on” cycle, energizing reversing valve solenoid and pulling in compressor contactor starting compressor and outdoor motor. R-G also make starting indoor blower motor. Heat pump heating cycle now in operation. The second option has no “Auto” changeover position, but instead energizes the reversing valve solenoid constantly whenever the system switch on subbase is placed in “Heat” position, the “B” terminal being constantly energized from R. A thermostat demand for heat completes R-Y circuit, pulling in compressor contactor starting compressor and outdoor motor. R-G also make starting indoor blower motor.

PRESSURE SERVICE PORTS

High and low pressure service ports are installed on all units so that the system operating pressures can be observed. Pressure tables covering all models can be found on page 27. It is imperative to match the correct pressure table to the unit by model number.

This unit employs high-flow Coremax valves instead of the typical Schrader type valves.

WARNING! Do NOT use a Schrader valve core removal tool with these valves. Use of such a tool could result in eye injuries or refrigerant burns!

To change a Coremax valve without first removing the refrigerant, a special tool is required which can be obtained at www.fastestinc.com/en/SCCA07H. See the replacement parts manual for replacement core part numbers.

DEFROST CYCLE

The defrost cycle is controlled by temperature and time on the solid state heat pump control.

When the outdoor temperature is in the lower 40°F temperature range or colder, the outdoor coil temperature is 32°F or below. This coil temperature is sensed by the coil temperature sensor mounted near the bottom of the outdoor coil. Once coil temperature reaches 30°F or below, the coil temperature sensor sends a signal to the control logic of the heat pump

control and the defrost timer will start accumulating run time.

After 30, 60 or 90 minutes of heat pump operation at 30°F or below, the heat pump control will place the system in the defrost mode.

During the defrost mode, the refrigerant cycle switches back to the cooling cycle, the outdoor motor stops, electric heaters are energized, and hot gas passing through the outdoor coil melts any accumulated frost. When the temperature rises to approximately 57°F, the coil temperature sensor will send a signal to the heat pump control which will return the system to heating operations automatically.

If some abnormal or temporary condition such as a high wind causes the heat pump to have a prolonged defrost cycle, the heat pump control will restore the system to heating operation automatically after 8 minutes.

The heat pump defrost control board has an option of 30, 60 or 90-minute setting. By default, this unit is shipped from the factory with the defrost time on the 60-minute pin. If circumstances require a change to another time, remove the wire from the 60-minute terminal and reconnect to the desired terminal. Refer to Figure 10 on page 23.

There is a cycle speed up jumper on the control. This can be used for testing purposes to reduce the time between defrost cycle operation without waiting for time to elapse.

Use a small screwdriver or other metallic object, or another 1/4" QC, to short between the *SPEEDUP* terminals to accelerate the HPC timer and initiate defrost.

Be careful not to touch any other terminals with the instrument used to short the *SPEEDUP* terminals. It may take up to 10 seconds with the *SPEEDUP* terminals shorted for the speedup to be completed and the defrost cycle to start.

As soon as the defrost cycle kicks in remove the shorting instrument from the *SPEEDUP* terminals.

Otherwise the timing will remain accelerated and run through the 1-minute minimum defrost length sequence in a matter of seconds and will automatically terminate the defrost sequence.

There is an initiate defrost jumper (sen jump) on the control that can be used at any outdoor ambient during the heating cycle to simulate a 0°F coil temperature.

This can be used to check defrost operation of the unit without waiting for the outdoor ambient to fall into the defrost region.

By placing a jumper across the *SEN JMP* terminals (a 1/4" QC terminal works best) the defrost sensor mounted on the outdoor coil is shunted out and will

activate the timing circuit. This permits the defrost cycle to be checked out in warmer weather conditions without the outdoor temperature having to fall into the defrost region.

In order to terminate the defrost test, the *SEN JMP* jumper must be removed. If left in place too long, the compressor could stop due to the high pressure control opening because of high pressure condition created by operating in the cooling mode with outdoor fan off. Pressure will rise fairly fast as there is likely no actual frost on the outdoor coil in this artificial test condition.

There is also a 5-minute compressor time delay function built into the HPC. This is to protect the compressor from short cycling conditions. The board's LED will have a fast blink rate when in the compressor time delay. In some instances, it is helpful to the service technician to override or speed up this timing period, and shorting out the *SPEEDUP* terminals for a few seconds can do this.

Low Pressure Switch Bypass Operation

The control has a selectable (SW1) low pressure switch bypass set up to ignore the low pressure switch input during the first (30, 60, 120 or 180 seconds) of "Y" operation.

After this period expires, the control will then monitor the low pressure switch input normally to make sure that the switch is closed during "Y" operation.

High Pressure Switch Operation

The control has a built-in lockout system that allows the unit to have the high pressure switch trip up to two times in 1 hour and only encounter a "soft" lockout. A "soft" lockout shuts the compressor off and waits for the pressure switch to reset, which at that point then allows the compressor to be restarted as long as the 5-minute short cycle timer has run out. If the high pressure switch trips a third time within 1 hour, the unit is in "hard" lockout indicating something is certainly wrong and it will not restart itself.

FIGURE 10
Defrost Control Board

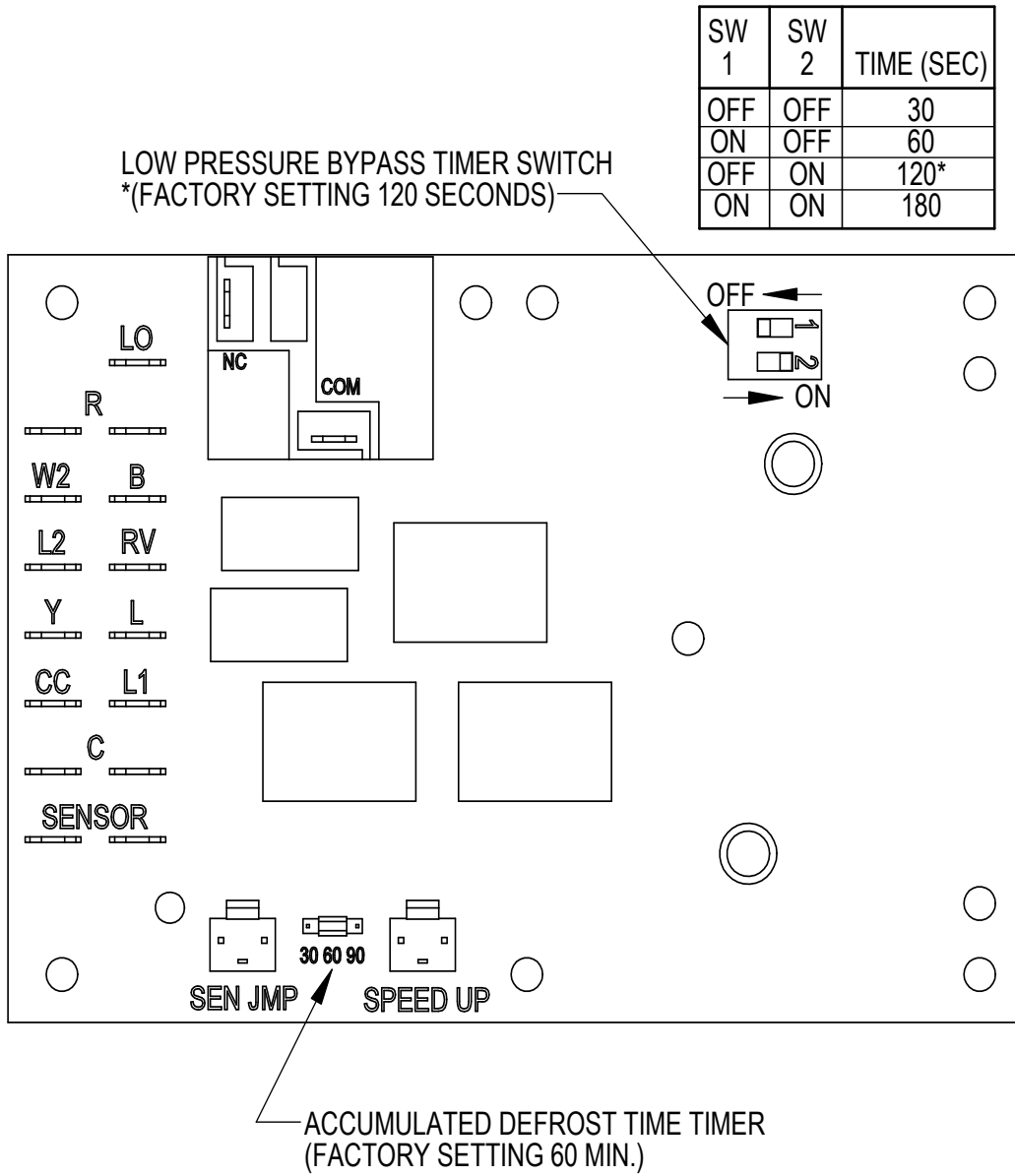

MIS-2668 A

Model	Setting
W18HA	60
W24HA	60
W30HA	30
W36HA	60
W42HA	60
W48HA	60
W60HA	30

SERVICE

SOLID STATE HEAT PUMP CONTROL TROUBLESHOOTING PROCEDURE

- NOTE:** A thorough understanding of the defrost cycle sequence is essential. Review that section (page 21) prior to troubleshooting the control. Turn on AC power supply to unit.
- Turn thermostat blower switch to “fan on”—the indoor blower should start. (If it doesn’t, troubleshoot indoor unit and correct problem.)
- Turn thermostat blower to “auto” position. Indoor blower should stop. **NOTE:** Many models have a 1-minute blower time delay on “off” command; wait for this to time out.
- Set system switch to “heat” or “cool”. Adjust thermostat to call for heat or cool. The indoor blower, compressor and outdoor fan should start.

NOTE: If there was no power to 24 volt transformer, the compressor and outdoor fan motor will not start for 5 minutes. This is because of the compressor short cycle protection.

LED BLINK CODES	
BLINK	FUNCTION
Slow	Normal function (1.0 sec on/1.0 sec off)
Fast	Compressor Delay timer active (0.1 sec on/0.1 sec off)
1	Low pressure switch failure
2	High pressure switch failure/“Soft” Lockout
3	Defrost mode active
4	High pressure switch failure/“Hard” Lockout

TABLE 5 – Troubleshooting

Symptom	Description, Check and Possible Causes	What & How to Check / Repair
Compressor will not start (heating or cooling)	1. Check for LED illumination. Is there an LED illuminated on the board (flashing)?	Yes = go to Step #2; No = go to Step #3
	2. Check for error codes. Is the LED flashing a Code?	Yes = go to Step #4; No = go to Step #8
	3. Check for power at board. Is there 24 volts AC between R and C?	Yes = go to Step #13; No = go to Step #9
	4. Check codes. What code is blinking?	Code "1", go to Step #6; Code "2", go to Step#7; Fast Blink, go to Step #5
	5. Compressor delay active. Wait for 5 minute delay or jump board's "speed up pins".	Check for proper operation; if still needed, go back to Step #1.
	6. Low pressure fault.	Check wiring circuit and unit pressures.
	7. High pressure fault.	Check wiring circuit and unit pressures.
	8. Check for Compressor input signal. Is there 24 volts AC between Y and C?	Yes = go to Step #10; No = go to Step #11
	9. No power to board.	The unit either does not have unit voltage, the transformer is bad or the unit wiring is incorrect.
	10. Check for Compressor output signal. Is there 24 volts AC between CC & C?	Yes = go to Step #12; No = go to Step #13
	11. No "Y" compressor input signal.	Check thermostat wiring, incorrect phase of unit (see section on Phase Monitor), and finally unit wiring.
	12. No "CC" compressor output signal.	Check compressor contactor for proper operation and finally check compressor.
	13. Faulty board.	Replace defrost board.
Fan outdoor motor does not run (cooling or heating except during defrost)	Heat pump control defective	Check across fan relay on heat pump control. (Com-NC) Replace heat pump control.
	Motor defective	Check for open or shorted motor winding. Replace motor.
	Motor capacitor defective	Check capacitor rating. Check for open or shorted capacitor. Replace capacitor.
Reversing valve does not energize (heating only)	Heat pump control defective	Check for 24V between RV-C and B-C. 1. Check control circuit wiring. 2. Replace heat pump control.
	Reversing valve solenoid coil defective	Check for open or shorted coil. Replace solenoid coil.
Unit will not go into defrost (heating only)	Temperature sensor or heat pump control defective	Disconnect temperature sensor from board and jumper across "SPEEDUP" terminals and "SEN JMP" terminals. This should cause the unit to go through a defrost cycle within one minute. 1. If unit goes through defrost cycle, replace temperature sensor. 2. If unit does not go through defrost cycle, replace heat pump control.
Unit will not come out of defrost (heating only)	Temperature sensor or heat pump control defective	Jumper across "SPEEDUP" terminal. This should cause the unit to come out of defrost within one minute. 1. If unit comes out of defrost cycle, replace temperature sensor. 2. If unit does not come out of defrost cycle, replace heat pump control.

CHECKING TEMPERATURE SENSOR OUTSIDE UNIT CIRCUIT

1. Disconnect temperature sensor from board and from outdoor coil.
2. Use an ohmmeter to measure the resistance of the sensor. Also use ohmmeter to check for short or open.
3. Check resistance reading to chart of resistance. Use sensor ambient temperature. (Tolerance of part is $\pm 10\%$.)
4. If sensor resistance reads very low, sensor is shorted and will not allow proper operation of the heat pump control.
5. If sensor is out of tolerance, shorted, open or reads very low ohms, it should be replaced.

Temperature F vs. Resistance R of Temperature Sensor

F	R	F	R	F	R	F	R
-25.0	196871	13.0	56985	53.0	19374	89.0	7507
-24.0	190099	14.0	55284	52.0	18867	90.0	7334
-23.0	183585	15.0	53640	53.0	18375	91.0	7165
-22.0	177318	16.0	52051	54.0	17989	92.0	7000
-21.0	171289	17.0	50514	55.0	17434	93.0	6840
-20.0	165487	18.0	49028	56.0	16984	94.0	6683
-19.0	159904	19.0	47590	57.0	16547	95.0	6531
-18.0	154529	20.0	46200	58.0	16122	96.0	6383
-17.0	149355	21.0	44855	59.0	15710	97.0	6239
-16.0	144374	22.0	43554	60.0	15310	98.0	6098
-15.0	139576	23.0	42295	61.0	14921	99.0	5961
-14.0	134956	24.0	41077	62.0	14544	100.0	5827
-13.0	130506	25.0	39898	63.0	14177	101.0	5697
-12.0	126219	26.0	38757	64.0	13820	102.0	5570
-11.0	122089	27.0	37652	65.0	13474	103.0	5446
-10.0	118108	28.0	36583	66.0	13137	104.0	5326
-9.0	114272	29.0	35548	67.0	12810	105.0	5208
-8.0	110575	30.0	34545	68.0	12492	106.0	5094
-7.0	107010	31.0	33574	69.0	12183	107.0	4982
-6.0	103574	32.0	32634	70.0	11883	108.0	4873
-5.0	100260	33.0	31723	71.0	11591	109.0	4767
-4.0	97064	34.0	30840	72.0	11307	110.0	4663
-3.0	93981	35.0	29986	73.0	11031	111.0	4562
-2.0	91008	36.0	29157	74.0	10762	112.0	4464
-1.0	88139	37.0	28355	75.0	10501	113.0	4367
0.0	85371	38.0	27577	76.0	10247	114.0	4274
1.0	82699	39.0	26823	77.0	10000	115.0	4182
2.0	80121	40.0	26092	78.0	9760	116.0	4093
3.0	77632	41.0	25383	79.0	9526	117.0	4006
4.0	75230	42.0	24696	80.0	9299	118.0	3921
5.0	72910	43.0	24030	81.0	9077	119.0	3838
6.0	70670	44.0	23384	82.0	8862	120.0	3757
7.0	68507	45.0	22758	83.0	8653	121.0	3678
8.0	66418	46.0	22150	84.0	8449	122.0	3601
9.0	64399	47.0	21561	85.0	8250	123.0	3526
10.0	62449	48.0	20989	86.0	8057	124.0	3452
11.0	60565	49.0	20435	87.0	7869		
12.0	58745	50.0	19896	88.0	7686		

FAN BLADE SETTING DIMENSIONS

The correct fan blade setting for proper air delivery across the outdoor coil is shown in Figure 11. Refer to Table 6 for unit specific dimension.

Any service work requiring removal or adjustment in the fan and/or motor area will require that the dimensions below be checked and blade adjusted in or out on the motor shaft accordingly.

FIGURE 11
Fan Blade Setting

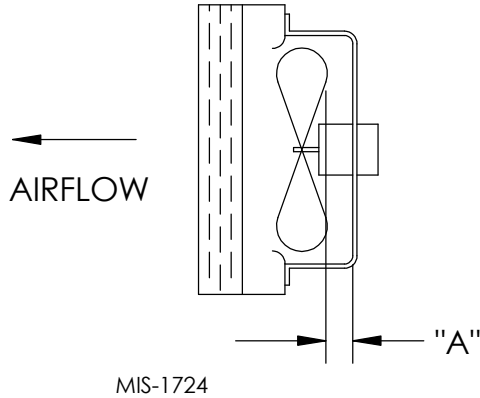

TABLE 6
Fan Blade Dimension

Model	Dimension A
W18HA W24HA	1.00"
W30HA W36HA	1.25"
W42HA W48HA W60HA	1.75"

REMOVAL OF FAN SHROUD

1. Disconnect all power to the unit.
2. Remove the screws holding both grilles, one on each side of unit, and remove grilles.
3. Remove nine screws holding fan shroud to condenser and bottom.
4. Unwire condenser fan motor.
5. Slide complete motor, fan blade and shroud assembly out the left side of the unit.
6. Service motor/fan as needed.
7. Reverse steps to reinstall.

R-410A REFRIGERANT CHARGE

This unit was charged at the factory with the quantity of refrigerant listed on the serial plate. AHRI capacity and efficiency ratings were determined by testing with this refrigerant charge quantity.

The following pressure tables show nominal pressures for the units. Since many installation specific situations can affect the pressure readings, this information should only be used by certified technicians as a guide for evaluating proper system performance. They shall not be used to adjust charge. If charge is in doubt, reclaim, evacuate and recharge the unit to the serial plate charge.

TABLE 7A – Cooling Pressure

Air Temperature Entering Outdoor Coil °F

Model	Return Air Temp (DB/WB)	Pressure	75	80	85	90	95	100	105	110	115	120	125
W18HA	75/62	Low Side	125	127	130	132	134	137	138	140	143	145	147
		High Side	278	298	321	343	367	391	415	441	467	494	523
	80/67	Low Side	134	136	139	141	143	146	148	150	153	155	157
		High Side	285	306	329	352	376	401	426	452	479	507	536
	85/72	Low Side	139	141	144	146	148	151	153	155	158	160	162
		High Side	295	317	341	364	389	415	441	468	496	525	555
W24HA	75/62	Low Side	126	128	130	132	134	136	137	139	141	144	146
		High Side	324	344	367	390	414	440	467	495	526	557	589
	80/67	Low Side	135	137	139	141	143	145	147	149	151	154	156
		High Side	332	353	376	400	425	451	479	508	539	571	604
	85/72	Low Side	140	142	144	146	148	150	152	154	156	159	161
		High Side	344	365	389	414	440	467	496	526	558	591	625
W30HA	75/62	Low Side	120	122	125	128	131	133	136	138	140	142	145
		High Side	309	331	352	375	401	426	453	482	511	541	573
	80/67	Low Side	128	131	134	137	140	142	145	148	150	152	155
		High Side	317	339	361	385	411	437	465	494	524	555	588
	85/72	Low Side	132	136	139	142	145	147	150	153	155	157	160
		High Side	328	351	374	398	425	452	481	511	542	574	609
W36HA	75/62	Low Side	129	131	133	135	137	138	140	142	144	146	148
		High Side	329	351	373	397	422	449	476	504	533	564	596
	80/67	Low Side	138	140	142	144	146	148	150	152	154	156	158
		High Side	337	360	383	407	433	460	488	517	547	578	611
	85/72	Low Side	143	145	147	149	151	153	155	157	159	161	164
		High Side	349	373	396	421	448	476	505	535	566	598	632
W42HA	75/62	Low Side	131	133	135	137	137	139	141	143	145	147	149
		High Side	319	339	361	384	409	434	460	488	517	547	579
	80/67	Low Side	140	142	144	146	147	149	151	153	155	157	159
		High Side	327	348	370	394	419	445	472	500	530	561	594
	85/72	Low Side	145	147	149	151	152	154	156	158	160	162	165
		High Side	338	360	383	408	434	461	489	518	549	581	615
W48HA	75/62	Low Side	126	129	131	133	136	137	139	141	143	145	147
		High Side	331	353	377	402	427	453	481	509	538	568	599
	80/67	Low Side	135	138	140	142	145	147	149	151	153	155	157
		High Side	339	362	387	412	438	465	493	522	552	583	614
	85/72	Low Side	140	143	145	147	150	152	154	156	158	160	162
		High Side	351	375	401	426	453	481	510	540	571	603	635
W60HA	75/62	Low Side	121	123	126	128	130	132	134	136	137	139	141
		High Side	324	347	371	396	422	449	476	504	532	563	593
	80/67	Low Side	129	132	135	137	139	141	143	145	147	149	151
		High Side	332	356	381	406	433	460	488	517	546	577	608
	85/72	Low Side	134	137	140	142	144	146	148	150	152	154	156
		High Side	344	368	394	420	448	476	505	535	565	597	629

Low side pressure ± 4 PSIG; High side pressure ± 10 PSIG

Tables are based upon rated CFM (airflow) across the evaporator coil. If there is any doubt as to correct operating charge being in the system, the charge should be removed and system evacuated and recharged to serial plate charge weight.

NOTE: Pressure table based on high speed condenser fan operation. If condensing pressures appear elevated check condenser fan wiring. See "Condenser Fan Operation".

TABLE 7B – Heating Pressure

Air Temperature Entering Outdoor Coil °F

Model	Return Air Temp	Pressure	0	5	10	15	20	25	30	35	40	45	50	55	60
W18HA	70	Low Side	50	55	60	65	71	78	85	92	100	108	116	125	135
		High Side	267	270	274	278	284	290	297	305	314	324	335	346	359
W24HA	70	Low Side	25	35	44	53	61	69	76	83	90	96	101	107	111
		High Side	261	270	279	288	297	306	315	324	333	342	352	361	370
W30HA	70	Low Side	50	51	54	57	61	67	73	81	90	99	110	122	135
		High Side	349	328	313	302	297	297	302	313	328	349	376	407	444
W36HA	70	Low Side	34	41	48	55	62	69	76	83	90	98	105	112	120
		High Side	428	374	330	298	276	264	263	273	294	325	366	419	482
W42H	70	Low Side	66	60	57	55	56	60	65	73	84	96	111	128	148
		High Side	326	313	303	298	296	298	305	315	329	348	370	396	426
W48H	70	Low Side	29	35	41	48	55	62	69	77	86	94	103	113	123
		High Side	293	292	294	297	302	309	317	328	340	354	369	387	406
W60H	70	Low Side	63	59	56	56	57	61	66	73	82	93	106	122	139
		High Side	529	462	408	368	342	328	328	341	368	408	461	528	608

TABLE 8

Electrical Specifications														
MODEL	Rated Volts & Phase	No. Field Power Circuits	Single Circuit				Dual Circuit							
			① Minimum Circuit Ampacity	② Maximum External Fuse or Ckt. Brkr.	③ Field Power Wire Size	④ Ground Wire	① Minimum Circuit Ampacity		② Maximum External Fuse or Ckt. Breaker		③ Field Power Wire Size		④ Ground Wire Size	
							Ckt. A	Ckt. B	Ckt. A	Ckt. B	Ckt. A	Ckt. B	Ckt. A	Ckt. B
W18HA-A00, A0Z A04 A08	230/208-1	1	16	20	12	12								
		1	37	40	8	10								
		1	57	60	6	10								
W24HA-A00, A0Z A04 A08	230/208-1	1	21	25	10	10								
		1	42	45	8	10								
		1 or 2	63	70	6	8	42	25	45	25	8	10	10	10
W24HA-B00, B0Z B06	230/208-3	1	15	20	12	12								
		1	33	35	8	10								
W24HA-C00, C0Z C06	460-3	1	9	15	14	14								
		1	18	20	12	12								
W30HA-A00, A0Z* A05* A10*	230/208-1	1	24	35	8	10								
		1	50	50	8	10								
		1 or 2	76	80	4	8	50	26	50	30	8	10	10	10
W30HA-B00, B0Z* B06 B09*	230/208-3	1	18	25	10	10								
		1	36	40	8	10								
		1	45	50	8	10								
W30HA-C00, C0Z* C06 C09* ③ C15	460-3	1	10	15	14	14								
		1	19	20	12	12								
		1	24	25	10	10								
		1	25	30	10	10								
W36HA-A00, A0Z* A05 A10* A15	230/208-1	1	29	40	8	10								
		1	55	60	6	10								
		1 or 2	81	90	4	8	55	26	60	30	6	10	10	10
		1 or 2	85	90	4	8	55	52	60	60	6	6	10	10
W36HA-B00, B0Z* B06 B09* ③ B15	230/208-3	1	23	30	10	10								
		1	41	45	8	10								
		1	50	50	8	10								
		1	52	60	6	10								
W36HA-C00, C0Z* C06 C09* ③ C15	460-3	1	11	15	14	14								
		1	20	25	10	10								
		1	24	25	10	10								
		1	25	30	10	10								
W42HA-A00, A0Z A04 A05 A10 ④ A15	230/208-1	1	30	45	8	10								
		1	51	60	6	10								
		1	56	60	6	10								
		1 or 2	82	90	4	8	30	52	45	60	8	6	10	10
		1 or 2	82	90	4	8	32	52	45	60	8	6	10	10
W42HA-B00, B0Z B06 B09 ③ B15	230/208-3	1	24	35	8	10								
		1	42	50	8	10								
		1	52	60	6	10								
		1	52	60	6	10								
W42HA-C00, C0Z C06 C09 ③ C15	460-3	1	12	15	14	14								
		1	21	25	10	10								
		1	25	30	10	10								
		1	26	30	10	10								
W48HA-A00, A0Z A04 A05 A10 ④ A15 ④ A20	230/208-1	1	35	50	8	10								
		1	56	60	6	10								
		1 or 2	61	70	6	8	35	26	50	30	8	10	10	10
		1 or 2	87	90	3	8	35	52	50	60	8	6	10	10
		1 or 2	87	90	3	8	35	52	50	60	8	6	10	10
		1 or 2	110	125	2	6	58	52	60	60	6	6	10	10
W48HA-B00, B0Z B06 B09 ③ B15 ③ B18	230/208-3	1	25	35	8	10								
		1	43	50	8	10								
		1	52	60	6	10								
		1	52	60	6	10								
		2	--	--	--	--	33	28	40	30	8	10	10	10
W48HA-C00, C0Z C09 ③ C15	460-3	1	12	15	14	14								
		1	26	30	10	10								
		1	26	30	10	10								
W60HA-A00, A0Z A05 A10 ④ A15 ④ A20	230/208-1	1	47	60	8	10								
		1 or 2	73	90	4	8	47	26	60	30	8	10	10	10
		1 or 2	99	110	3	6	47	52	60	60	8	6	10	10
		1 or 2	99	110	3	6	47	52	60	60	8	6	10	10
		1 or 2	112	125	2	6	60	52	60	60	6	6	10	10
W60HA-B00, B0Z B09 ③ B15 ③ B18	230/208-3	1	32	40	8	10								
		1	59	60	6	10								
		1	59	60	6	10								
		2	--	--	--	--	35	28	40	30	8	10	10	10
W60HA-C00, C0Z C09 ③ C15	460-3	1	16	20	12	12								
		1	29	35	8	10								
		1	29	35	8	10								

① These "Minimum Circuit Ampacity" values are to be used for sizing the field power conductors. Refer to the National Electrical code (latest version), Article 310 for power conductor sizing. **CAUTION:** When more than one field power circuit is run through one conduit, the conductors must be derated. Pay special attention to note 8 of Table 310 regarding Ampacity Adjustment Factors when more than three (3) current carrying conductors are in a raceway.

② Maximum size of the time delay fuse or circuit breaker for protection of field wiring conductors.

③ Maximum KW that can operate with the heat pump on is 9KW. Full heat available during emergency heat mode.

④ Maximum KW that can operate with the heat pump on is 10KW. Full heat available during emergency heat mode.

⑤ Based on 75°C copper wire. All wiring must conform to the National Electrical Code and all local codes.

* Available factory-built only with top outlet supply as an option.

IMPORTANT: While this electrical data is presented as a guide, it is important to electrically connect properly sized fuses and conductor wires in accordance with the National Electrical Code and all local codes.

**TABLE 9
Recommended Airflow**

Model	Rated CFM *	Rated ESP *	Recommended Airflow Range	Factory Speed Connection
W18H	600 ①	.20	575 - 725	Low
W24H	800	.20	700 - 925	Single
W30H	1000	.40	930 - 1300	High
W36H	1100	.30	930 - 1350	High
W42H	1400	.40	1250 - 1700	High
W48H	1550	.20	1275 - 1700	High
W60H	1700	.20	1500 - 1950	Medium

* Rated CFM and ESP on high speed tap.

① Rated CFM and ESP on low speed tap.

**TABLE 10
Indoor Blower Performance**

Speed	W18HA				W24HA		W30HA, W36HA				W42HA, W48HA				W60HA					
	High		Low		Single		High		Low		High		Low		High		Medium		Low	
	Dry Coil	Wet Coil	Dry Coil	Wet Coil	Dry Coil	Wet Coil	Dry Coil	Wet Coil	Dry Coil	Wet Coil	Dry Coil	Wet Coil	Dry Coil	Wet Coil	Dry Coil	Wet Coil	Dry Coil	Wet Coil	Dry Coil	Wet Coil
.0	980	970	725	720	960	920	1435	1400	960	960	1840	1790	1655	1605	2095	1995	1910	1820	1795	1715
.1	920	905	670	655	920	860	1400	1335	935	945	1755	1700	1565	1530	2040	1950	1850	1760	1730	1655
.2	850	825	630	610	860	790	1300	1250	925	905	1665	1615	1490	1455	1985	1900	1790	1700	1665	1600
.3	785	755	580	550	790	705	1230	1160	895	880	1570	1515	1410	1370	1925	1850	1735	1630	1605	1540
.4	715	680	530	490	700	610	1125	1075	840	810	1465	1410	1320	1280	1875	1800	1675	1570	1545	1475
.5	610	565	455	390	565	450	1010	940	765	735	1355	1280	1215	980	1820	1745	1615	1500	1475	1310

TABLE 11
Maximum ESP of Operation
Electric Heat Only

Model		ESP
W18H	A00	.50
W24H	A04	.40
	A08	.35
W24H	B00	.50
	B06	.40
W24H	C00	.50
	C06	.40

Model		Front Outlet	
		Low Speed	High Speed
W30H	A00	.50	.50
	A05	.40	.50
W36H	A10	.35	.40
	A15	.35	.40
	B00	.50	.50
W30H	B06	.40	.50
W36H	B09	.30	.35
	B15	.30	.35
	C00	.50	.50
W30H	C06	.40	.50
W36H	C09	.30	.40
	C15	.30	.40

Model Speed KW	W42H		W48H		W60H	
	High Speed	Low Speed	High Speed	Low Speed	High Speed	Low Speed
-A00	.50	.50	.50	.50	.50	.40
-A04	----	----	.50	.50	----	----
-A05	.50	.50	.50	.50	.50	.25
-A10	.50	.45	.50	.45	.50	.25
-A15	.50	.45	.50	.45	.50	.25
-A20	----	----	.50	.45	.50	.25
-B00	.50	.50	.50	.50	.50	.40
-B09	.50	.45	.50	.45	.50	.30
-B15	.50	.45	.50	.45	.50	.30
-B18	----	----	.50	.45	.50	.30
-C00	.50	.50	.50	.50	.50	.40
-C09	.50	.40	.50	.40	.50	.35
-C15	.50	.40	.50	.40	.50	.35

TABLE 12
Electric Heat

Models	240V-1		208V-1		240V-3		208V-3		460V-3		
	KW	Amps	BTUH	Amps	BTUH	Amps	BTUH	Amps	BTUH	Amps	BTUH
4		16.7	13650	14.4	10240						
5		20.8	17065	18.1	12800						
6						14.4	20500	12.5	15360	7.2	20500
8		33.3	27300	28.8	20475						
9						21.7	30600	18.7	23030	10.8	30700
10		41.6	34130	36.2	25600						
15		62.5	51250	54.0	38400	36.2	51200	31.2	38400	18.0	51200
18						43.3	61430	37.5	46100		
20		83.2	68260	72.1	51200						

TABLE 13
Optional Accessories

Part Number	W18HA-A	W24HA-A	W24HA-B	W24HA-C	W30HA-A	W30HA-B	W30HA-C	W36HA-A	W36HA-B	W36HA-C	W42HA-A	W42HA-B	W42HA-C	W48HA-A	W48HA-B	W48HA-C	W60HA-A	W60HA-B	W60HA-C	
HEATER KITS	EHW18H-A04	X																		
	EHW18H-A08	X																		
	EHW2TH-A04		X																	
	EHW2TH-A08		X																	
	EHWH24-B06B			X																
	EHWH24B-C06				X															
	EHWH30-A05					X														
	EHW30H-A10					X														
	EHWH36-A05								X											
	EHW3TH-A10								X											
	EHW3TH-A15								X											
	EHWH03-B06						X													
	EHW36H-B06									X										
	EHWH03-B09						X			X										
	EHW3TH-B15									X										
	EHW3TH-C06							X			X									
	EHW3TA-C09							X			X									
	EHW3TH-C15							X			X									
	EHW4TH-A05											X								
	EHWH42-A05B														X					
	EHW4TH-A10											X			X					
	EHW4TH-A15											X								
	EHWH42-A15B											X			X					
	EHWH04-A20B														X			X		
	EHWH05-B06B												X			X				
	EHWH05-B09B												X			X			X	
	EHWH05-B15B												X			X			X	
	EHW4TH-C06													X						
	EHW4TH-C09													X			X			X
	EHW4TH-C15													X			X			X
	EHWH04-A15B																		X	
	EHW5TH-A10																		X	
	EHW4TH-B18															X				X
CIRCUIT BREAKER (WMCB) & PULL DISCONNECT (WMPD)	WMCB-02A	X																		
	WMCB-02B			X																
	WMCB-03A		X																	
	WMCB-03B					X			X											
	WMCB-06A					X			X											
	WMCB-05B											X			X			X		
	WMCB-07B										X									
	WMCB-08A														X					
	WMCB-09A																	X		
	WMPD-01C				X			X			X			X			X			X

TABLE 14
Vent and Control Options

Part Number	Description	W18, W24	W30, W36	W42, W48, W60
CMH-27	Low Ambient Control – Heat Pump (LAC)	X	X	
CMH-28	Outdoor Thermostat – Heat Pump (ODT)	X	X	
CMH-29	LAC and ODT – Heat Pump	X	X	
CMH-30	LAC and Start Kit (1-PH only) ②	X	X	
CMH-31	LAC, ODT and Start Kit (1-PH only) ②	X	X	
CMH-22	Low Ambient Control – Heat Pump			X
CMH-23	Outdoor Thermostat – Heat Pump (ODT)			X
CMH-24	LAC and ODT – Heat Pump			X
CMH-25	LAC and Start Kit (1-PH only) ②			X
CMH-26	LAC, ODT and Start Kit (1-PH only) ②			X
CMC-15	Start Relay (PTCR based) ①	X	X	X
SK-111	Start Kit (Hard Start) ②	X	X	X
BFAD-2	Barometric Fresh Air Damper – Standard	X		
BOP-2	Blank-Off Plate	X		
WMFADP2	Motorized Fresh Air Damper	X		
WCRVPS2	Commercial Ventilator – Spring Return	X		
WECOPE2	Economizer – Bldg. Equipment, Enthalpy	X		
WECOPT2	Economizer – Bldg. Equipment, DB Temp.	X		
WERVPA2	Energy Recovery Ventilator – 230 Volt	X		
WERVPC2	Energy Recovery Ventilator – 460 Volt	X		
BFAD-3	Barometric Fresh Air Damper – Standard		X	
BOP-3	Blank-Off Plate		X	
WMFADP3	Motorized Fresh Air Damper		X	
WCRVPS3	Commercial Ventilator – Spring Return		X	
WECOPE3	Economizer – Bldg. Equipment, Enthalpy		X	
WECOPT3	Economizer – Bldg. Equipment, DB Temp.		X	
WERVPA3	Energy Recovery Ventilator – 230 Volt		X	
WERVPC3	Energy Recovery Ventilator – 460 Volt		X	
BFAD-5	Barometric Fresh Air Damper – Standard			X
BOP-5	Blank-Off Plate			X
WMFADP5	Motorized Fresh Air Damper			X
WCRVPS5	Commercial Ventilator – Spring Return			X
WECOPE5	Economizer – Bldg. Equipment, Enthalpy			X
WECOPT5	Economizer – Bldg. Equipment, DB Temp.			X
WERVPA5	Energy Recovery Ventilator – 230 Volt			X
WERVPC5	Energy Recovery Ventilator – 460 Volt			X

① PTCR Start Kit can be used with all -A single phase models. Increases starting torque 2-3x. Not used for -B or -C three phase models. Do not use if SK111 is used.

② Start capacitor and potential relay start kit can be used with all -A single phase models. Increases starting torque 9x. Not used for -B or -C three phase models. Do not use if CMC-15 is used.