INSTALLATION AND SERVICE INSTRUCTIONS

MULTI-TEC® WALL-MOUNT AIR CONDITIONER *Part of the Bard Free Cooling Unit System*

Models:

W18AAPA	W36AAPC	W60AAPC	W18LAPA	W48LAPA
W24AAPA	W42AAPA	W60AAPQ	W24LAPA	W48LAPB
W24AAPB	W42AAPB	W72AAPA	W24LAPB	W48LAPC
W24AAPC	W42AAPC	W72AAPB	W30LAPA	W48LAPQ
W30AAPA	W48AAPA	W72AAPC	W30LAPB	W60LAPA
W30AAPB	W48AAPB	W72AAPQ	W30LAPC	W60LAPB
W30AAPC	W48AAPC		W36LAPA	W60LAPC
W36AAPA	W48AAPQ		W36LAPB	W60LAPQ
W36AAPB	W60AAPA		W36LAPC	W72LAPA
	W60AAPB		W42LAPA	W72LAPB
			W42LAPB	W72LAPC
			W42LAPC	W72LAPQ

NOTE: LC6000 Controller is required for operation when multiple WAP units are used.***



Climate Control Solutions

Bard Manufacturing Company, Inc.
Bryan, Ohio 43506
www.bardhvac.com

Manual : 2100-665B
Supersedes: 2100-665A
Date: 7-10-17

CONTENTS

SECTION 1: Installation Instructions	5
List of Necessary Materials/Tools	6
Site Preparation	7
Wall-Mount Unit Installation	9
Wall-Mount Unit Supply Wiring.....	17
Preliminary Start-Up.....	21
Running in Stand Alone (Orphan) Mode.....	21
SECTION 2: Service Instructions	23
Using the TEC-EYE™	24
Alarms.....	27
Alarm Adjustment	27
Control Operation.....	29
On/Off Control	29
Fan Control	29
Temperature Control.....	29
Freecooling	31
Compressor	32
General Refrigerant Information.....	34
Componentry	36
Maintenance and Troubleshooting.....	40
SECTION 3: Appendix	43
Wall-Mount Unit Architecture.....	44

FIGURES AND TABLES

Figure 1.1	MULTI-TEC Model Nomenclature	6	Table 1.1	Electrical Specifications: W**AAP Series.....	18
Figure 1.2	Dimensions.....	8	Table 1.2	Electrical Specifications: W**LAP Series.....	19
Figure 1.3	Outdoor Sensor Installation	9	Table 1.3	Recommended Airflow	20
Figure 1.4A	W18/24 Mounting Instructions	10	Table 1.4	Indoor Blower Performance.....	20
Figure 1.4B	W30/36 Mounting Instructions	11	Table 1.5	Maximum ESP of Operation: Electric Heat Only	20
Figure 1.4C	W42/48 Mounting Instructions	12	Table 2.1	Cooling Pressures	35
Figure 1.4D	W60/72 Mounting Instructions	13	Table 2.2A	Optional Accessories – Right Hand.....	38
Figure 1.5	Electric Heat Clearance.....	14	Table 2.2B	Optional Accessories – Left Hand.....	39
Figure 1.6	Wall Mounting Instructions.....	14			
Figure 1.7	Wall Mounting Instructions.....	15			
Figure 1.8	Common Wall Mounting Installations.....	16			
Figure 1.9	Circuit Routing Label	17			
Figure 1.10	WIRING: VAC Supply Wiring Landing Points.....	17			
Figure 2.1	TEC-EYE™ Display and Interface.....	24			
Figure 2.2	TEC-EYE™ Connection to Unit Control....	24			
Figure 2.3	Quick Menu Icons	25			
Figure 2.4	Local and Current Cool/Heat Setpoints....	25			
Figure 2.5	Executing Run Test.....	26			
Figure 2.6	Adjusting Mixed Air Alarm Values.....	27			
Figure 2.7	Adjusting Damper Alarm Values	28			
Figure 2.8	LC6000 Status Screen Showing Control Values	29			
Figure 2.9	Wall-Mount Unit Cooling Staging.....	29			
Figure 2.10	Adjusting Cooling Differential Values	30			
Figure 2.11	Adjusting Heating Differential Values.....	30			
Figure 2.12	Wall-Mount Unit Heating Staging	30			
Figure 2.13	Economizer A4 Screen	31			
Figure 2.14	Economizer A5 Screen	31			
Figure 2.15	Adjusting Damper Modulation Value	32			
Figure 2.16	Wall-Mount Unit Control Board	33			
Figure 2.17	Fan Blade Setting.....	37			

GENERAL INFORMATION

FREE COOLING UNIT SYSTEM

The Bard Free Cooling Unit System is composed of MULTI-TEC wall-mounted air conditioners matched with an LC6000 lead/lag controller. The wall mounts are specifically engineered for telecom/motor control center rooms.

NOTE: *The LC6000 lead/lag controller and MULTI-TEC wall-mount units are designed specifically to work together. The controller cannot run other Bard models or other brands of systems, nor can other controllers run the MULTI-TEC wall-mount units. They are a complete system, and must be used together.*

WALL-MOUNT AIR CONDITIONER UNITS

The MULTI-TEC units operate on VAC power. The units will supply 100% of rated cooling airflow in free cooling mode with ability to exhaust the same amount through the unit itself without any additional relief openings in the shelter.

Each of these units are fully charged with refrigerant and have optional auxilliary heat.

GENERAL

The equipment covered in this manual is to be installed by trained, experienced service and installation technicians.

The refrigerant system is completely assembled and charged. All internal wiring is complete.

The unit is designed for use with or without duct work. Flanges are provided for attaching the supply and return ducts.

These instructions explain the recommended method to install the air cooled self-contained unit and the electrical wiring connections to the unit.

These instructions and any instructions packaged with any separate equipment required to make up the entire air conditioning system should be carefully read before beginning the installation. Note particularly any tags and/or labels attached to the equipment.

While these instructions are intended as a general recommended guide, they do not supersede any national and/or local codes in any way. Authorities having jurisdiction should be consulted before the installation is made. See **ADDITIONAL PUBLICATIONS** for information on codes and standards.

Sizing of systems for proposed installation should be based on heat loss and heat gain calculations made according to methods of Air Conditioning Contractors of America (ACCA). The air duct should be installed

in accordance with the *Standards of the National Fire Protection Association for the Installation of Air Conditioning and Ventilating Systems of Other Than Residence Type, NFPA No. 90A, and Residence Type Warm Air Heating and Air Conditioning Systems, NFPA No. 90B*. Where local regulations are at a variance with instructions, installer should adhere to local codes.

SHIPPING DAMAGE

Upon receipt of equipment, the cartons should be checked for external signs of shipping damage. If damage is found, the receiving party must contact the last carrier immediately, preferably in writing, requesting inspection by the carrier's agent.

These units must remain in upright position at all times.

ADDITIONAL PUBLICATIONS

These publications can help when installing the furnace. They can usually be found at the local library or purchased directly from the publisher. Be sure to consult the current edition of each standard.

National Electrical CodeANSI/NFPA 70
Standard for the Installation of Air Conditioning and Ventilating SystemsANSI/NFPA 90A
Standard for Warm Air Heating and Air Conditioning SystemsANSI/NFPA 90B
Load Calculation for Residential Winter and Summer Air Conditioning ACCA Manual J
Duct Design for Residential Winter and Summer Air Conditioning and Equipment Selection ACCA Manual D

For more information, contact these publishers:

Air Conditioning Contractors of America (ACCA)

1712 New Hampshire Ave. N.W.
Washington, DC 20009
Telephone: (202) 483-9370 Fax: (202) 234-4721

American National Standards Institute (ANSI)

11 West Street, 13th Floor
New York, NY 10036
Telephone: (212) 642-4900 Fax: (212) 302-1286

American Society of Heating, Refrigeration and Air Conditioning Engineers, Inc. (ASHRAE)

1791 Tullie Circle, N.E.
Atlanta, GA 30329-2305
Telephone: (404) 636-8400 Fax: (404) 321-5478

National Fire Protection Association (NFPA)

Batterymarch Park
P. O. Box 9101
Quincy, MA 02269-9901
Telephone: (800) 344-3555 Fax: (617) 984-7057

ANSI Z535.5 Definitions:

DANGER: Indicate[s] a hazardous situation which, if not avoided, will result in death or serious injury. The signal word “DANGER” is to be limited to the most extreme situations. DANGER [signs] should not be used for property damage hazards unless personal injury risk appropriate to these levels is also involved.

WARNING: Indicate[s] a hazardous situation which, if not avoided, could result in death or serious injury. WARNING [signs] should not be used for property damage hazards unless personal injury risk appropriate to this level is also involved.

CAUTION: Indicate[s] a hazardous situation which, if not avoided, could result in minor or moderate injury. CAUTION [signs] without a safety alert symbol may be used to alert against unsafe practices that can result in property damage only.

NOTICE: [this header is] preferred to address practices not related to personal injury. The safety alert symbol shall not be used with this signal word. As an alternative to “NOTICE” the word “CAUTION” without the safety alert symbol may be used to indicate a message not related to personal injury.



WARNING

Electrical shock hazard.
Have a properly trained individual perform these tasks.
Failure to do so could result in electric shock or death.

WARNING

Fire hazard.
Maintain minimum 1/4" clearance between the supply air duct and combustible materials in the first 3' feet of ducting.
Failure to do so could result in fire causing damage, injury or death.

WARNING

Heavy item hazard.
Use more than one person to handle unit.
Failure to do so could result in unit damage or serious injury.

CAUTION

Cut hazard.
Wear gloves to avoid contact with sharp edges.
Failure to do so could result in personal injury.

SECTION 1:

INSTALLATION

INSTRUCTIONS

LIST OF NECESSARY MATERIALS/TOOLS

Additional hardware and miscellaneous supplies are needed for installation. These items are field supplied and must be sourced before installation. This list also includes tools needed for installation.

LIST OF MATERIALS/TOOLS

- Personal protective equipment/safety devices
- Supply/return grilles
- Field-fabricated sleeves (if necessary)
- Fasteners sufficient for mounting the units such as 5/16" diameter anchor/carriage/lag bolts
- 7/8" diameter washers
- Caulking materials
- Miscellaneous hand and power tools and jobsite or shop materials
- Lifting equipment with the necessary capacity and rigging to safely move/install the systems
- Electrical supplies
 - Various size circuit breakers for the shelter AC breaker box (see Tables 1.1 and 1.2 on pages 18 and 19)
 - High-voltage wire of various gauges (see Tables 1.1 and 1.2)
 - Communication wire: 2-wire, 18 gauge, shielded with drain
 - Miscellaneous electrical supplies including rigid/flexible conduit and fittings, junction boxes, wire connectors and supports

FIGURE 1.1
MULTI-TEC Wall-Mount Unit Model Nomenclature

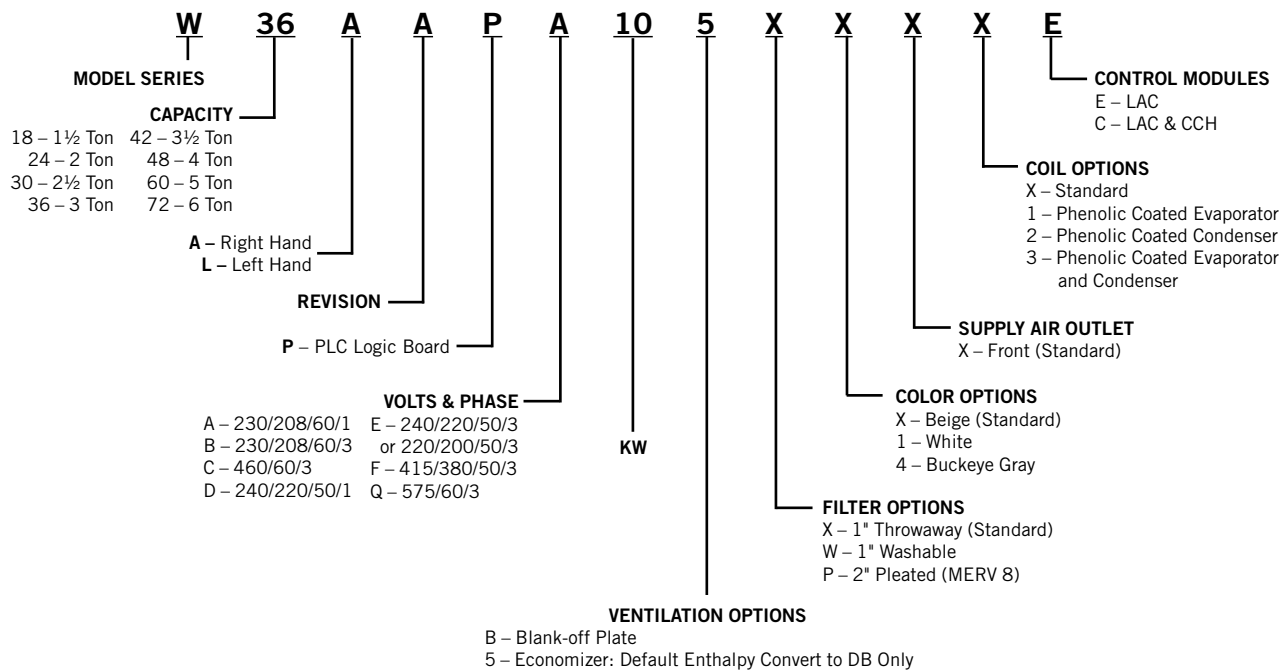

MODEL IDENTIFICATION

Identify the specific model using the model nomenclature information found in Figure 1.1 and the model/serial tag found on the unit on the opposite side of the control and access panels. See Figure 1.2 on page 8 for dimensions and critical installation requirements.

NEW SHELTER INSTALLATION VS. RETROFIT INSTALLATION

These installation instructions cover both new shelter installations and retrofit installations. Each installation is unique and may require special accommodations and modifications. Although Bard Manufacturing follows a long-established tradition of manufacturing equipment using industry standard dimensions for building penetration, it is occasionally necessary to move or enlarge supply and return openings when replacing non-standardized equipment in a retrofit application.

MINIMUM CLEARANCE

Wall-mount air conditioners are available in both right-hand access models and left-hand access models. Right-hand access models have the heat strip access panel, external circuit breakers access panel and internal controls access panel on the right side of the unit. Left-hand access models are a mirror image of the right-hand access models, and allow two wall-mount units to be placed in relatively close proximity and yet still allow complete access for maintenance and repair.

On side-by-side installations, maintain a minimum of 20" clearance on control side to allow access to control panel and heat strips, and to allow proper airflow to the outdoor coil. For installations where units are installed with both control panels facing each other (inward), maintain a minimum of 36" clearance to allow access. Additional clearance may be required to meet local or national codes.

Care should be taken to ensure that the recirculation and obstruction of condenser discharge air does not occur. Recirculation of condenser discharge air can be from either a single unit or multiple units. Any object such as shrubbery, a building or a large object can cause obstructions to the condenser discharge air. Recirculation or reduced airflow caused by obstructions will result in reduced capacity, possible unit pressure safety lockouts and reduced unit service life.

For units with blow through condensers, such as these wall-mount units, it is recommended there be a minimum distance of 10' between the front of the unit and any barrier or 20' between the fronts of two opposing (facing) units.

Clearances Required for Service Access and Adequate Condenser Airflow

MODELS	LEFT SIDE	RIGHT SIDE	DISCHARGE SIDE
W18A, W24A, W30A, W36A	15"	20"	10'
W18L, W24L, W30L, W36L	20"	15"	10'
W42A, W48A, W60A, W72A	20"	20"	10'
W42L, W48L, W60L, W72L	20"	20"	10'

NOTE: For side-by-side installation of two units there must be 20" between units. This can be reduced to 15" by using a W**L model (left side compressor and controls) for the left unit and W**A (right side compressor and controls) for right unit.

See Specifications Sheet S3532.

CLEARANCE TO COMBUSTIBLES

WARNING

Fire hazard.

Maintain minimum 1/4" clearance between the supply air duct and combustible materials in the first 3' of ducting.

Failure to do so could result in fire causing damage, injury or death.

The unit itself is suitable for 0" clearance, but the supply air duct flange and the first 3' of supply air duct require a minimum of 1/4" clearance to combustible material. However, it is generally recommended that a 1" clearance is used for ease of installation and maintaining the required clearance to combustible material. See Figures 1.4A-D on pages 10-13 for details on opening sizes.

Minimum Clearances Required to Combustible Materials

MODELS	SUPPLY AIR DUCT FIRST 3'	CABINET
W18A, L W24A, L	0"	0"
W30A, L W36A, L	1/4"	0"
W42A, L W48A, L W60A, L W72A, L	1/4"	0"

WALL-MOUNT UNIT INSTALLATION

MOUNTING THE UNITS

WARNING

Heavy item hazard.

Use more than one person to handle unit.

Failure to do so could result in unit damage or serious injury.

NOTE: It may be best to spot some electrical knockouts (such as those located on the back of the wall-mount unit) before units are mounted and access is unavailable or limited (see Figure 1.2 to locate pre-punched knockouts).

Two holes for the supply and return air openings must be cut through the wall as shown in Figures 1.4A-D on pages 10-13. On wood frame walls, the wall construction must be strong and rigid enough to carry the weight of the unit without transmitting any unit vibration. All walls must be thoroughly inspected to insure that they are capable of carrying the weight of the installed unit.

In retrofit (unit replacement) installations, the openings cut for the original equipment may not line up exactly with needs of this installation. Modifications may need to be made, such as increasing or decreasing the size of the wall cutouts. The existing bolt placement may not line up in which case the original bolts would need to be removed or cut away.

1. These units are secured by wall mounting flanges which secure the unit to the outside wall surface at both sides. A bottom mounting bracket, attached to skid for shipping, is provided for ease of installation, but is not required.
2. The unit itself is suitable for 0" clearance, but the supply air duct flange and the first 3' of supply air duct require a minimum of 1/4" clearance to combustible material. However, it is generally recommended that a 1" clearance is used for ease of installation and maintaining the required clearance to combustible material. See Figures 1.4A-D for details on opening sizes.
3. Locate and mark lag bolt locations and location for optional bottom mounting bracket, if desired (see Figures 1.4A-D).
4. Mount bottom mounting bracket (if used).

5. If desired, hook top rain flashing (attached to front-right of supply flange for shipping) under back bend of top.
6. Position unit in opening and secure with fasteners sufficient for the application such as 5/16" lag/anchor/carriage bolts; use 7/8" diameter flat washers on the lag bolts. It is recommended that a bead of silicone caulking be placed behind the side mounting flanges.
7. Secure optional rain flashing to wall and caulk across entire length of top (see Figures 1.4A-D).
8. For additional mounting rigidity, the return air and supply air frames or collars can be drilled and screwed or welded to the structural wall itself (depending upon wall construction). Be sure to observe required clearance if combustible wall.
9. A plastic drain hose extends from the drain pan at the top of the unit down to the unit base. There are openings in the unit base for the drain hose to pass through. In the event the drain hose is connected to a drain system of some type, it must be an open or vented type system to assure proper drainage.
10. Install outdoor temperature/humidity sensor (see Figure 1.3). Remove grommet from base and sensor. Discard shipping bracket. Place sensor extension through hole in base under condenser fan and secure to base with screw.

FIGURE 1.3
Outdoor Sensor Installation



FIGURE 1.4A
W18A, W18L, W24A, W24L
Mounting Instructions

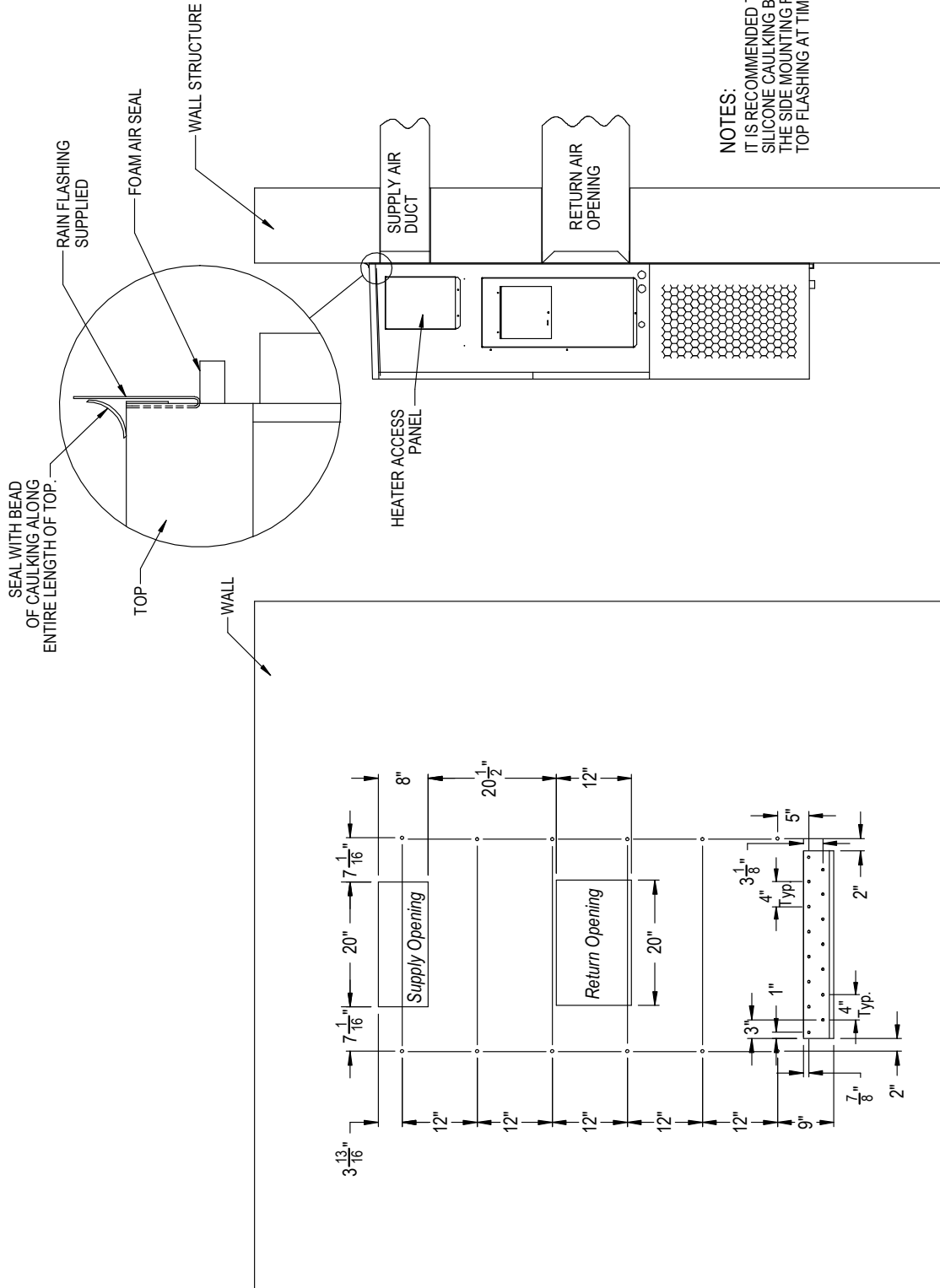

MIS-3157 A

FIGURE 1.4B
W30A, W30L, W36A, W36L
Mounting Instructions

	A	B	C	D	E
REQUIRED DIMENSIONS TO MAINTAIN 1/4" MIN. CLEARANCE FROM COMBUSTIBLE MATERIALS	28 3/8	8 3/8	5 3/8	3 11/16	17 5/8
REQUIRED DIMENSIONS TO MAINTAIN RECOMMENDED 1" CLEARANCE FROM COMBUSTIBLE MATERIALS	29 7/8	9 7/8	4 5/8	4 7/16	16 7/8

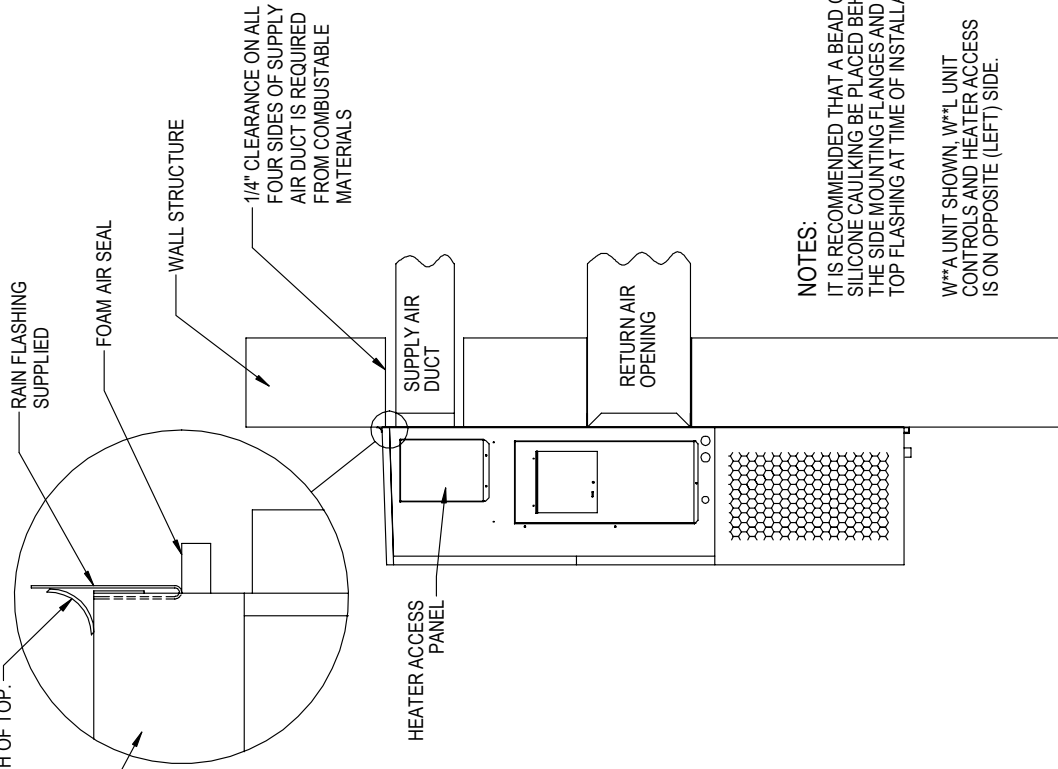

NOTES:
 IT IS RECOMMENDED THAT A BEAD OF SILICONE CAULKING BE PLACED BEHIND THE SIDE MOUNTING FLANGES AND UNDER TOP FLASHING AT TIME OF INSTALLATION.
 W**A UNIT SHOWN, W**L UNIT CONTROLS AND HEATER ACCESS IS ON OPPOSITE (LEFT) SIDE.

Right Side View

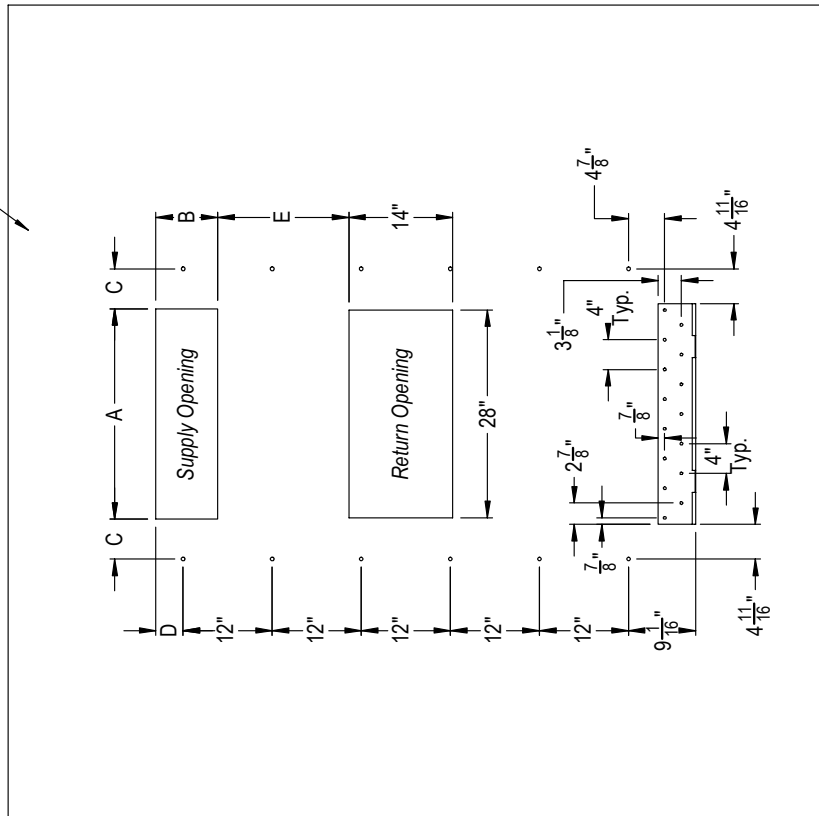

Wall Opening and Hole Location View

MIS-3820

FIGURE 1.4C
W42A, W42L, W48A, W48L
Mounting Instructions

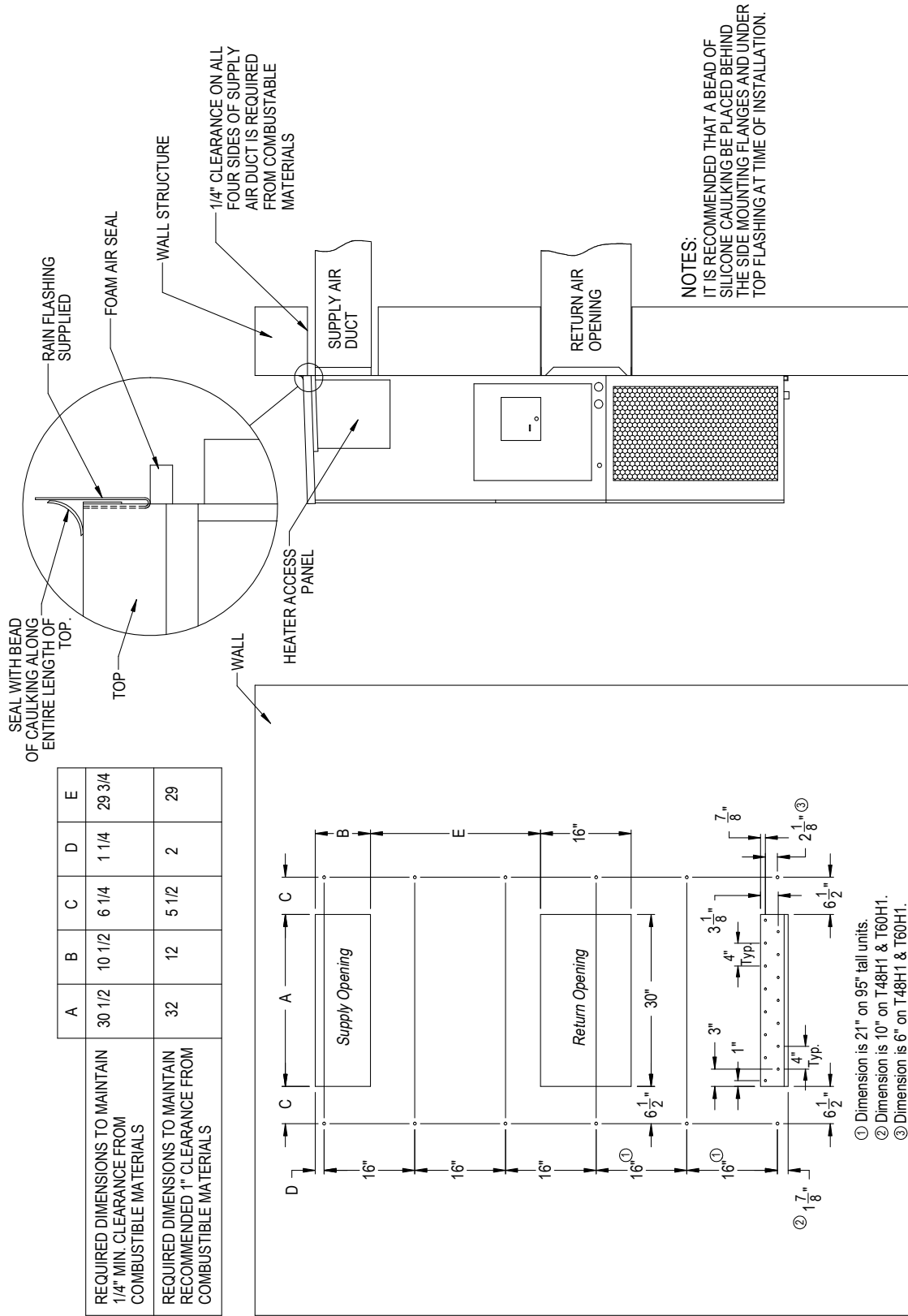
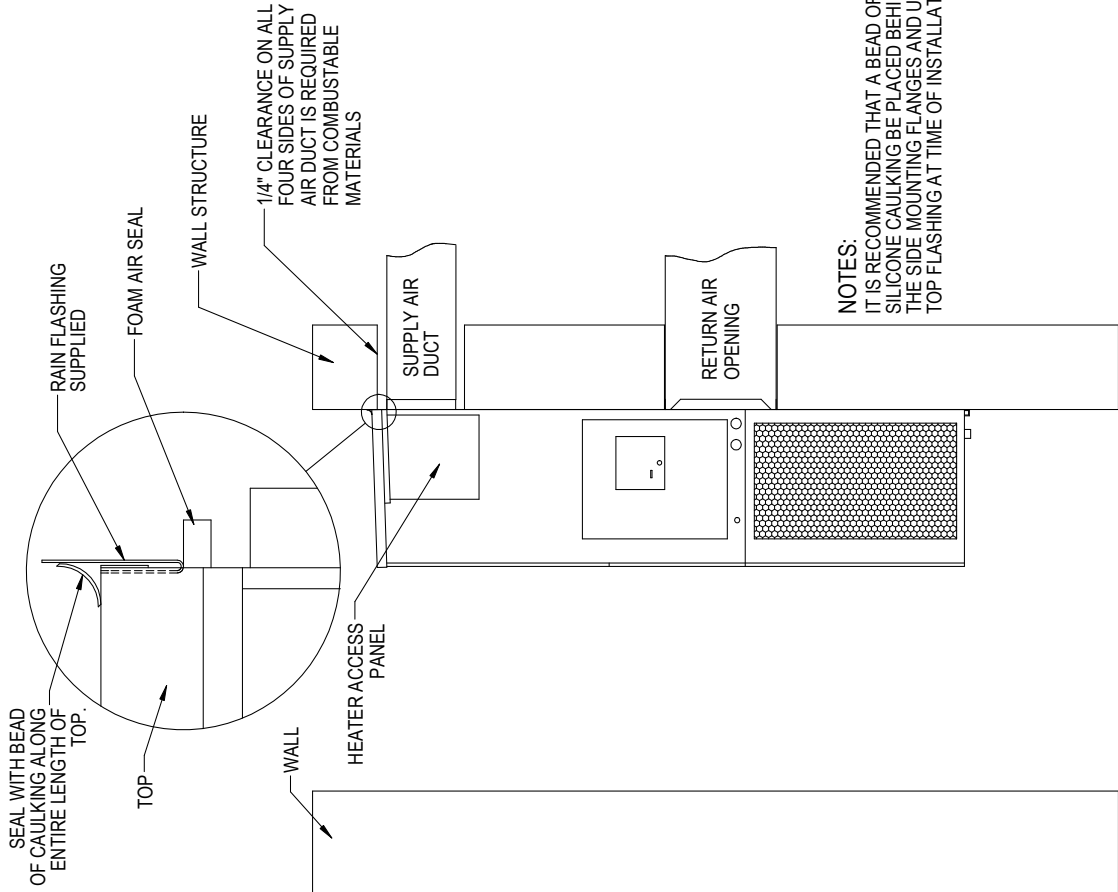

FIGURE 1.4D
W60A, W60L, W72A, W72L
Mounting Instructions



NOTES:
 IT IS RECOMMENDED THAT A BEAD OF SILICONE CAULKING BE PLACED BEHIND THE SIDE MOUNTING FLANGES AND UNDER TOP FLASHING AT TIME OF INSTALLATION.

Right Side View

	A	B	C	D	E
REQUIRED DIMENSIONS TO MAINTAIN 1/4" MIN. CLEARANCE FROM COMBUSTIBLE MATERIALS	30 1/2	10 1/2	6 1/4	1 1/4	29 3/4
REQUIRED DIMENSIONS TO MAINTAIN RECOMMENDED 1" CLEARANCE FROM COMBUSTIBLE MATERIALS	32	12	5 1/2	2	29

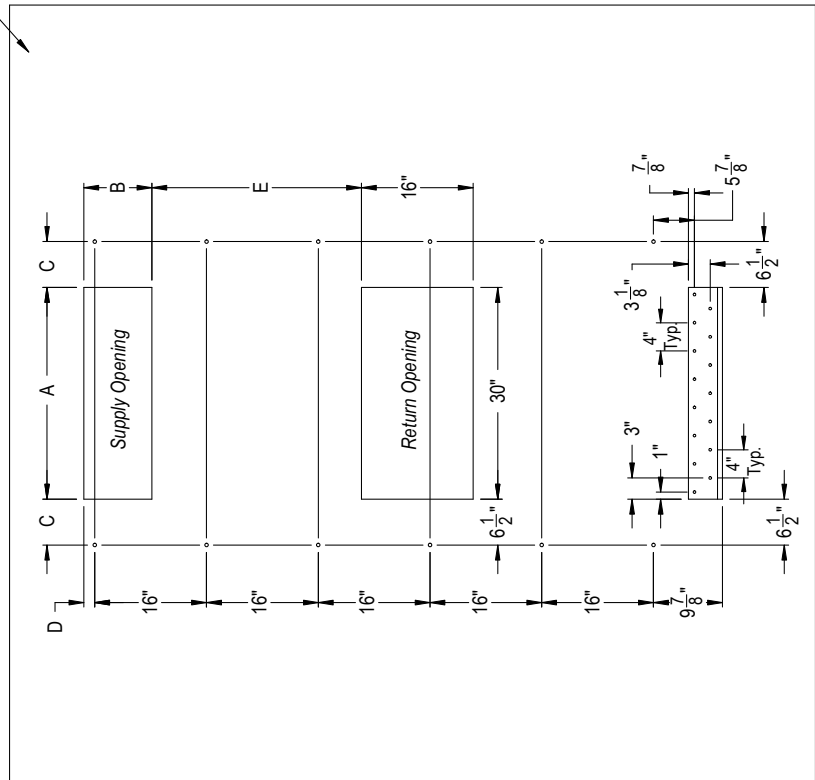

Wall Opening and Hole Location View

FIGURE 1.5
Electric Heat Clearance

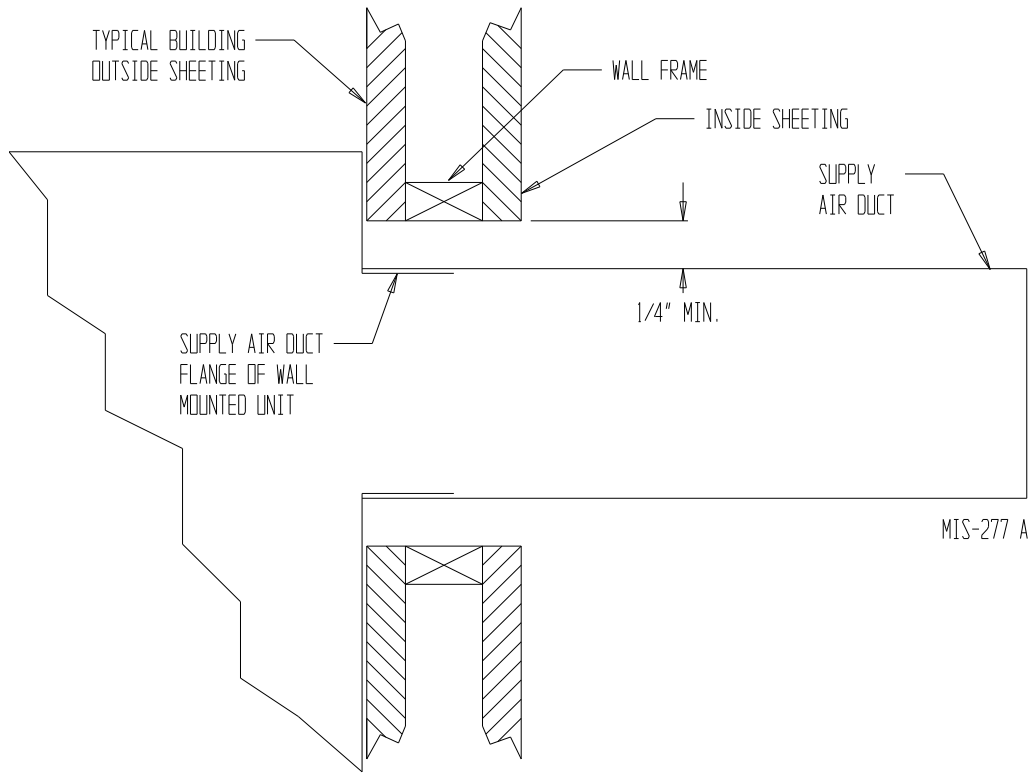

FIGURE 1.6
Wall Mounting Instructions

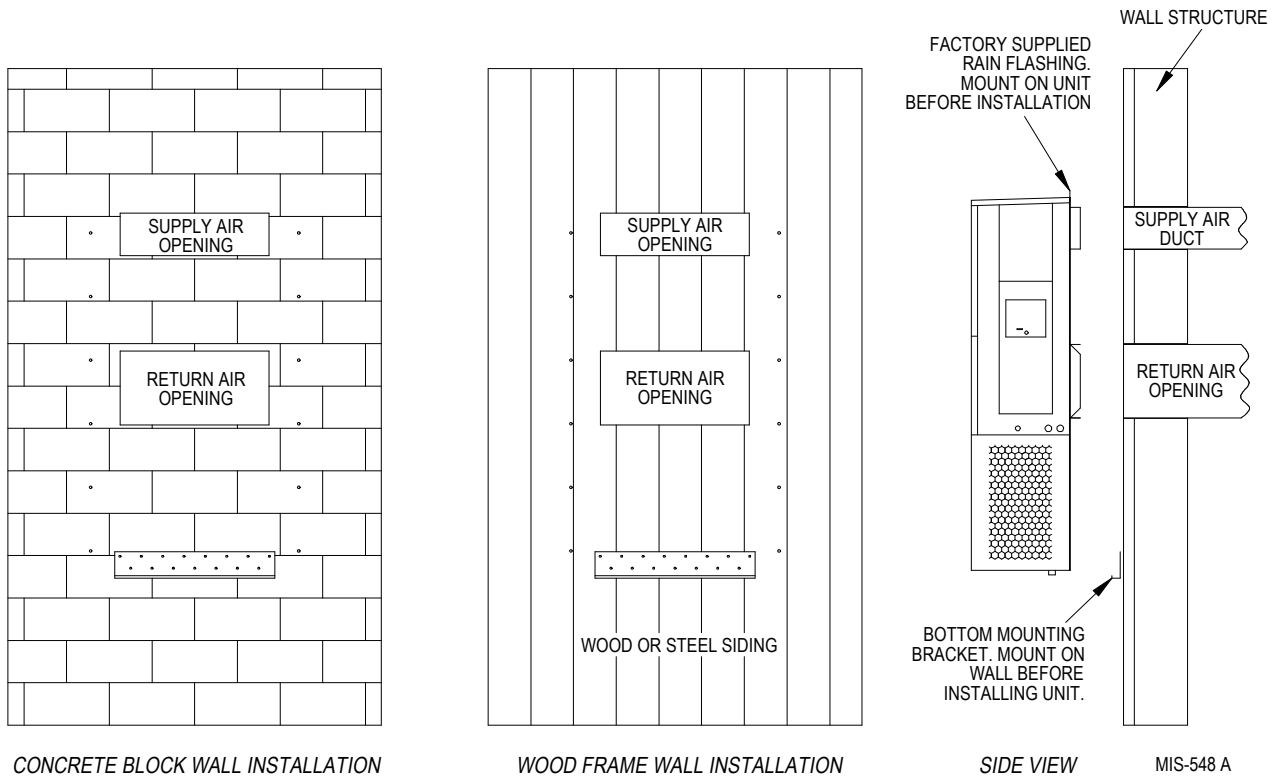

FIGURE 1.7
Wall Mounting Instructions

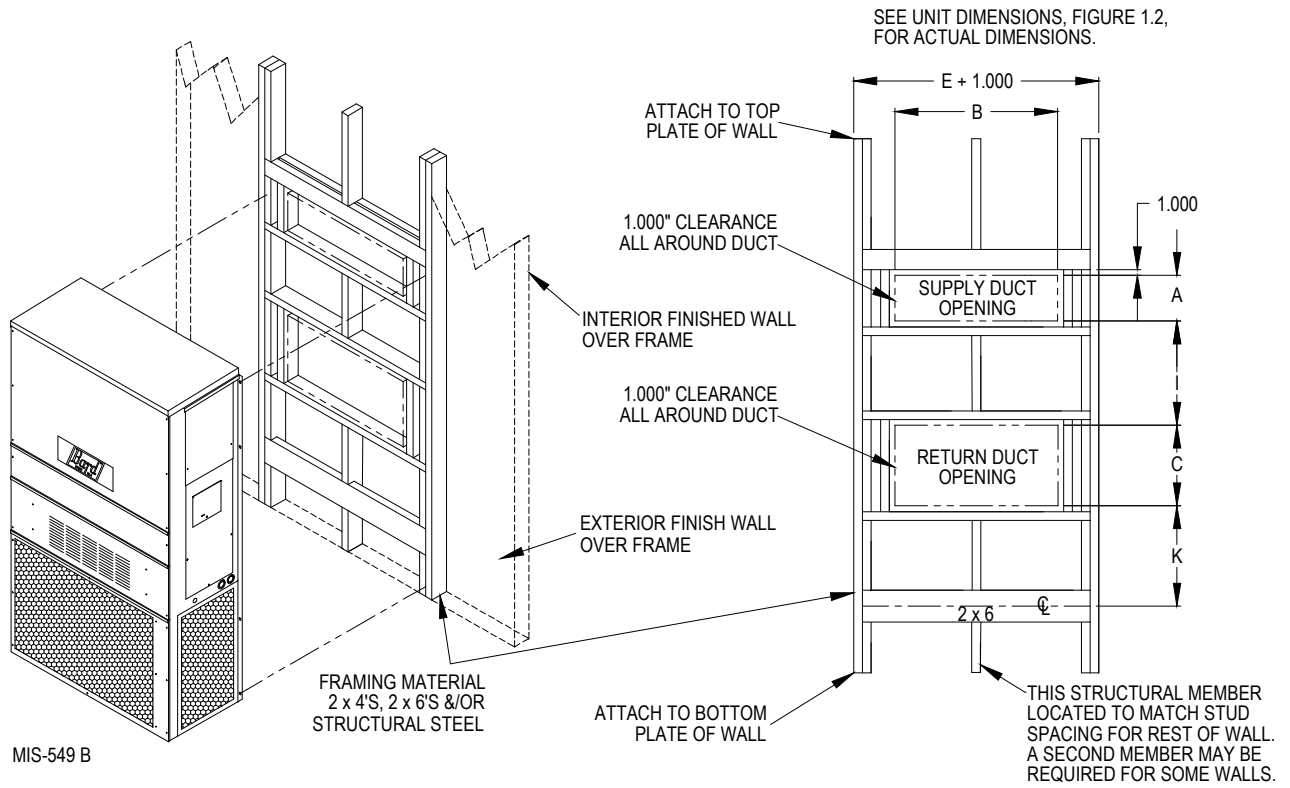
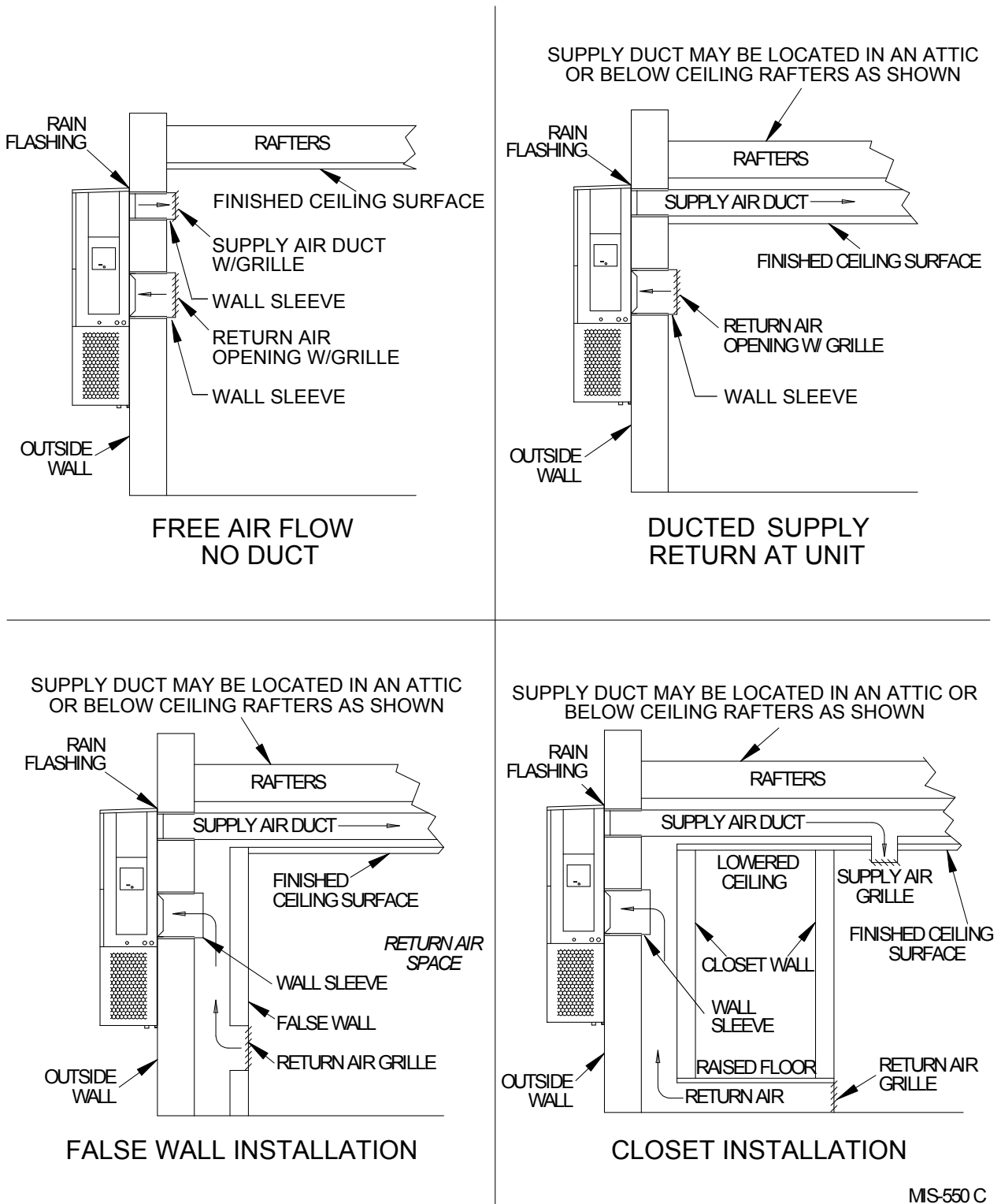

FIGURE 1.8
Common Wall Mounting Installations



MS-550 C

WALL-MOUNT UNIT SUPPLY WIRING

⚠ WARNING

Electrical shock hazard.

Have a properly trained individual perform these tasks.

Failure to do so could result in electric shock or death.

MAIN POWER WIRING

Refer to the unit rating plate or Table 1.1 (page 18) or Table 1.2 (page 19) for wire sizing information and maximum fuse or circuit breaker size. Each outdoor unit is marked with a “Minimum Circuit Ampacity”. The field wiring used must be sized to carry that amount of current. Depending on the installed KW of electric heat, there may be two field power circuits required. If this is the case, the unit rating plate will so indicate. All models are suitable only for connection with copper wire. Each unit and/or wiring diagram will be marked “Use Copper Conductors Only”. These instructions **must be** adhered to. Refer to the National Electrical Code (NEC) for complete current carrying capacity data on the various insulation grades of wiring material. All wiring must conform to NEC and all local codes.

The unit rating plate and Tables 1.1 and 1.2 list fuse and wire sizes (75°C copper) for all models including the most commonly used heater sizes. Also shown are the number of field power circuits required for the various models with heaters.

The unit rating plate lists a maximum circuit breaker or fuse that is to be used with the equipment. The correct size must be used for proper circuit protection and also to assure that there will be no nuisance tripping due to the momentary high starting current of the compressor motor.

Route all field wires to the right of the wire shield as shown in the circuit routing label found in Figure 1.9 (and also on the wall-mount units).

See Figure 1.10 to reference VAC landing points.

The disconnect access door on this unit may be locked to prevent unauthorized access to the disconnect. To convert for the locking capability, bend the tab located in the bottom left-hand corner of the disconnect opening under the disconnect access panel straight out. This tab will now line up with the slot in the door. When shut, a padlock may be placed through the hole in the tab preventing entry.

FIGURE 1.9
Circuit Routing Label

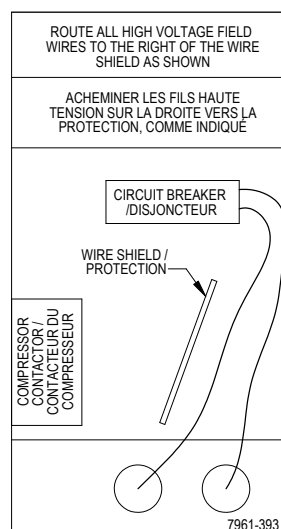
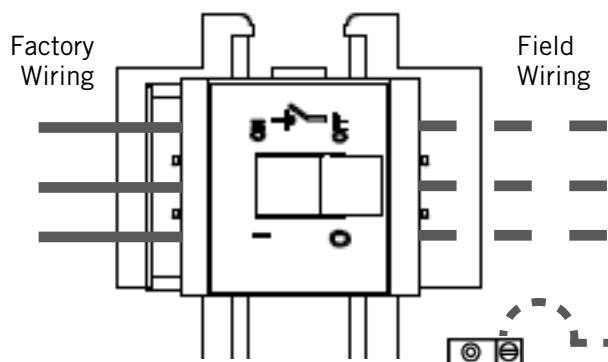

FIGURE 1.10
VAC Supply Wiring Landing Points



NOTE: Right-hand access model wiring landing points are shown here; left-hand access models will mirror this image.

LOW VOLTAGE WIRING

230/208V 1 phase and 3 phase equipment use dual primary voltage transformers. All equipment leaves the factory wired on 240V tap. **It is very important that the correct voltage tap is used.** For 208V operation, reconnect from 240V to 208V tap. The acceptable operating voltage range for the 240 and 208V taps are: 240V Tap (253 – 216) and 208 Tap (220 – 197).

NOTE: The voltage should be measured at the field power connection point in the unit and while the unit is operating at full load (maximum amperage operating condition).

For low voltage wiring, an 18 gauge copper, color-coded cable is recommended.

TABLE 1.1

Electrical Specifications – W**AAP Series																		
MODEL	Rated Volts & Phase	No. Field Power Circuits	Single Circuit				Multiple Circuit											
			③ Minimum Circuit Ampacity	① Maximum External Fuse or Ckt. Brkr.	② Field Power Wire Size	② Ground Wire	③ Minimum Circuit Ampacity			① Maximum External Fuse or Ckt. Breaker			② Field Power Wire Size			② Ground Wire Size		
							Ckt. A	Ckt. B	Ckt. C	Ckt. A	Ckt. B	Ckt. C	Ckt. A	Ckt. B	Ckt. C	Ckt. A	Ckt. B	Ckt. C
W18AAPA00, A0Z A05 A08 A10	230/208-1	1	16	20	12	12												
		1	30	30	10	10												
		1	46	50	8	10												
		1	56	60	6	10												
W24AAPA00, A0Z A04 A05 A08 A10	230/208-1	1	21	30	10	10												
		1	25	30	10	10												
		1	30	30	10	10												
		1	46	50	8	10												
W24AAPB00, B0Z B06	230/208-3	1	15	20	12	12												
		1	22	25	10	10												
		1	9	15	14	14												
		1	11	15	14	14												
W24AAPC00, C0Z C06	460-3	1	9	15	14	14												
		1	11	15	14	14												
		1	26	35	8	10												
		1	32	35	8	10												
W30AAPA00, A0Z A05 A08 A10 A15	230/208-1	1	26	35	8	10												
		1	32	35	8	10												
		1	47	50	8	10												
		1 or 2	58	60	6	10	58	26	60	30	6	10		10	10			
W30AAPB00, B0Z B06 B09 B15	230/208-3	1	19	20	12	12												
		1	24	25	10	10												
		1	33	35	8	10												
		1	51	60	6	10												
W30AAPC00, C0Z C06 C09 C12 C15	460-3	1	9	15	14	14												
		1	12	15	14	14												
		1	17	20	12	12												
		1	21	25	10	10												
W36AAPA00, A0Z A05 A08 A10 A15	230/208-1	1	29	35	8	10												
		1	32	35	8	10												
		1	47	50	8	10												
		1 or 2	58	60	6	10	58	26	60	30	6	10		10	10			
W36AAPB00, B0Z B06 B09 B15	230/208-3	1	23	30	10	10												
		1	24	30	10	10												
		1	33	35	8	10												
		1	51	60	6	10												
W36AAPC00, C0Z C06 C09 C12 C15	460-3	1	11	15	14	14												
		1	12	15	14	14												
		1	17	20	12	12												
		1	21	25	10	10												
W42AAPA00, A0Z A05 A10 A15 A20	230/208-1	1	32	50	8	10												
		1	32	50	8	10												
		1	58	60	6	10												
		1 or 2	84	90	4	8	58	26	60	30	6	10		10	10			
W42AAPB00, B0Z B06 B09 B15 B18	230/208-3	1	25	35	8	10												
		1	25	35	8	10												
		1	33	35	8	10												
		1	51	60	6	10												
W42AAPC00, C0Z C09 C15	460-3	1	12	15	14	14												
		1	17	20	12	12												
		1	26	30	10	10												
		1	26	30	10	10												
W48AAPA00, A0Z A05 A10 A15 A20	230/208-1	1	34	50	8	10												
		1	34	50	8	10												
		1	58	60	6	10												
		1 or 2	84	90	4	8	58	26	60	30	6	10		10	10			
W48AAPB00, B0Z B06 B09 B15 B18	230/208-3	1	26	35	8	10												
		1	26	35	8	10												
		1	33	35	8	10												
		1	51	60	6	10												
W48AAPC00, C0Z C09 C15	460-3	1	12	15	14	14												
		1	17	20	12	12												
		1	26	30	10	10												
		1	26	30	10	10												
W48AAPQ00, Q0Z Q15	575-3	1	12	15	14	14												
		1	24	25	10	10												
W60AAPA00, A0Z A05 A10 A15 A20	230/208-1	1	38	60	8	10												
		1	38	60	8	10												
		1	60	60	6	10												
		1 or 2	86	90	3	8	60	26	60	30	6	10		10	10			
W60AAPB00, B0Z B06 B09 B15 B18	230/208-3	1	27	40	8	10												
		1	27	40	8	10												
		1	35	40	8	10												
		2	N/A	N/A	N/A	N/A	35	28	40	30	8	10		10	10			
W60AAPC00, C0Z C09 C15	460-3	1	14	20	12	12												
		1	18	20	12	12												
		1	27	30	10	10												
W60AAPQ00, Q0Z Q15	575-3	1	13	20	12	12												
		1	24	25	12	12												
W72AAPA00, A0Z A05 A10 A15 A20	230/208-1	1	58	60	6	10												
		1	58	60	6	10												
		1 or 2	62	70	6	8	58	26	60	30	6	10		10	10			
		1 or 3	88	90	3	8	58	52	52	60	60	6	6	6	10	10	10	
W72AAPB00, B0Z B06 B09 B15 B18	230/208-3	1	40	60	8	10												
		1	40	60	8	10												
		1	40	60	8	10												
		2	N/A	N/A	N/A	N/A	40	28	60	30	8	10		10	10			
W72AAPC00, C0Z C09 C15	460-3	1	18	25	10	10												
		1	18	25	10	10												
		1	27	30	10	10												
W72AAPQ00, Q0Z Q15	575-3	1	14	20	12	12												
		1	24	25	10	10												

See footnotes under TABLE 1.2

TABLE 1.2

Electrical Specifications – WLAP Series**

MODEL	Rated Volts & Phase	No. Field Power Circuits	Single Circuit				Dual Circuit							
			③ Minimum Circuit Ampacity	① Maximum External Fuse or Ckt. Brkr.	② Field Power Wire Size	② Ground Wire	③ Minimum Circuit Ampacity		① Maximum External Fuse or Ckt. Breaker		② Field Power Wire Size		② Ground Wire Size	
							Ckt. A	Ckt. B	Ckt. A	Ckt. B	Ckt. A	Ckt. B	Ckt. A	Ckt. B
W18LAPA00, A0Z A05 A08 A10	230/208-1	1 1 1 1	16 30 46 56	20 30 50 60	12 10 8 6	12 10 10 10								
W24LAPA00, A0Z A05 A08 A10	230/208-1	1 1 1 1	21 30 46 56	30 30 50 60	10 10 8 6	10 10 10 10								
W24LAPB00, B0Z B06	230/208-3	1 1	15 22	20 25	12 10	12 10								
W24LAPC00, C0Z C06	460-3	1 1	9 11	15 15	14 14	14 14								
W30LAPA00, A0Z A05 A08 A10 A15	230/208-1	1 1 1 1 1 or 2	26 32 47 58 84	35 35 50 60 90	8 8 8 6 4	10 10 10 10 8								
W30LAPB00, B0Z B09 B15	230/208-3	1 1 1	19 33 51	20 35 60	12 8 6	12 10 10								
W30LAPC00, C0Z C09 C15	460-3	1 1 1	9 17 26	15 20 30	14 12 10	14 12 10								
W36LAPA00, A0Z A05 A10 A15	230/208-1	1 1 1 1 or 2	29 32 58 84	35 35 60 90	8 8 6 4	10 10 10 8	58	26	60	30	6	10	10	10
W36LAPB00, B0Z B09 B15	230/208-3	1 1 1	23 33 51	30 35 60	10 8 6	10 10 10								
W36LAPC00, C0Z C09 C15	460-3	1 1 1	11 17 26	15 20 30	14 12 10	14 12 10								
W42LAPA00, A0Z A05 A10 A15	230/208-1	1 1 1 1 or 2	32 32 58 84	50 50 60 90	8 8 6 4	10 10 10 8	58	26	60	30	6	10	10	10
W42LAPB00, B0Z B06 B09 B15	230/208-3	1 1 1 1	25 25 33 51	35 35 35 60	8 8 8 6	10 10 10 10								
W42LAPC00, C0Z C09 C15	460-3	1 1 1	12 17 26	15 20 30	14 12 10	14 12 10								
W48LAPA00, A0Z A05 A10 A15	230/208-1	1 1 1 1 or 2	34 34 58 84	50 50 60 90	8 8 6 4	10 10 10 8	58	26	60	30	6	10	10	10
W48LAPB00, B0Z B06 B09 B15	230/208-3	1 1 1 1	26 26 33 51	35 35 35 60	8 8 8 6	10 10 10 10								
W48LAPC00, C0Z C09 C15	460-3	1 1 1	12 17 26	15 20 30	14 12 10	14 12 10								
W48LAPQ00, Q0Z Q15	575-3	1 1	12 24	15 25	14 10	14 10								
W60LAPA00, A0Z A05 A10 A15	230/208-1	1 1 1 1 or 2	38 38 60 86	60 60 60 90	8 8 6 3	10 10 10 8	60	26	60	30	6	10	10	10
W60LAPB00, B0Z B06 B09 B15	230/208-3	1 1 1 1	27 27 35 53	40 40 40 60	8 8 8 6	10 10 10 10								
W60LAPC00, C0Z C09 C15	460-3	1 1 1	14 18 27	20 20 30	12 12 10	12 12 10								
W60LAPQ00, Q0Z Q15	575-3	1 1	13 24	20 25	12 12	12 12								
W72LAPA00, A0Z A05 A10 A15	230/208-1	1 1 1 1 or 2	58 58 62 88	60 60 70 90	6 6 8 3	10 10 10 8	58	26	60	30	6	10	10	10
W72LAPB00, B0Z B06 B09 B15	230/208-3	1 1 1 1	40 40 40 55	60 60 60 60	8 8 8 6	10 10 10 10								
W72LAPC00, C0Z C09 C15	460-3	1 1 1	18 18 27	25 25 30	10 10 10	10 10 10								
W72LAPQ00, Q0Z Q15	575-3	1 1	14 24	20 25	12 10	12 10								

- ① Maximum size of the time delay fuse or circuit breaker for protection of field wiring conductors.
- ② Based on 75°C copper wire. All wiring must conform to the National Electrical Code and all local codes.
- ③ These "Minimum Circuit Ampacity" values are to be used for sizing the field power conductors. Refer to the National Electrical code (latest version), Article 310 for power conductor sizing.

CAUTION: When more than one field power circuit is run through one conduit, the conductors must be derated. Pay special attention to Note 8 of Table 310 regarding Ampacity Adjustment Factors when more than three current carrying conductors are in a raceway.

IMPORTANT: While this electrical data is presented as a guide, it is important to electrically connect properly sized fuses and conductor wires in accordance with the National Electrical Code and all local codes.

**TABLE 1.3
Recommended Airflow**

Model	Nominal Rated CFM *	Nominal Rated ESP *	Recommended Airflow Range	Factory Speed Connection
W18A, W18L	600	.35	550 - 725	Low
W24A, W24L	800	.30	700 - 950	Single
W30A, W30L	1000	.45	900 - 1200	High
W36A, W36L	1100	.30	1000 - 1300	High
W42A, W42L	1350	.40	1250 - 1600	Low
W48A, W48L	1550	.35	1450 - 1750	High
W60A, W60L	1800	.30	1700 - 2000	High
W72A, W72L	1900	.25	1800 - 2100	Medium

* Rated CFM and ESP on factory speed connection.

**TABLE 1.4
Indoor Blower Performance**

Speed	W18		W24		W30				W36				W42				W48				W60				W72							
	High	Low	Single	High	Low	High	Low	High	Low	High	Low	High	Low	High	Low	High	Low	High	Low	High	Low	High	Medium	Low	High	Medium	Low					
ESP (Inch H2O)	Dry Coil	Wet Coil	Dry Coil	Wet Coil	Dry Coil	Wet Coil	Dry Coil	Wet Coil	Dry Coil	Wet Coil	Dry Coil	Wet Coil	Dry Coil	Wet Coil	Dry Coil	Wet Coil	Dry Coil	Wet Coil	Dry Coil	Wet Coil	Dry Coil	Wet Coil	Dry Coil	Wet Coil	Dry Coil	Wet Coil	Dry Coil	Wet Coil				
0.0	1000	985	720	720	1010	975	1445	1380	940	930	1400	1310	965	955	1980	1940	1800	1705	2000	1940	1750	1700	2105	2010	1540	1460	2255	2155	2075	2015	1995	1930
0.1	965	950	700	690	960	925	1385	1320	930	920	1340	1260	940	930	1905	1880	1700	1640	1910	1865	1675	1615	2045	1960	1480	1395	2185	2095	2010	1965	1950	1870
0.2	935	900	665	660	905	870	1305	1240	920	910	1265	1185	905	890	1820	1760	1615	1565	1820	1770	1600	1540	1970	1885	1400	1315	2115	2035	1960	1915	1885	1825
0.3	880	845	635	625	835	800	1220	1150	985	880	1180	1100	860	850	1735	1665	1530	1450	1720	1605	1500	1425	1895	1800	1300	1220	2050	1970	1915	1865	1835	1785
0.4	795	760	590	575	750	720	1125	1055	850	830	1080	1010	800	785	1615	1565	1425	1350	1575	1500	1375	1320	1800	1700	1220	1150	1985	1920	1860	1815	1780	1720
0.5	680	645	520	510	640	610	1020	950	785	750	970	895	705	680	1510	1380	1100	1000	1420	1190	1075	1030	1705	1605	1110	1070	1925	1855	1810	1765	1725	1615

**TABLE 1.5
Maximum ESP of Operation
Electric Heat Only**

Model	W18A/L, W24A/L	W30A/L, W36A/L		W42A/L, W48A/L		W60A/L, W72A/L	
Outlet	FRONT	FRONT		FRONT		FRONT	
Speed	Single	High	Low	High	Low	High	Low
-A0Z	.50	.50	.50	.50	.50	.50	.50
-A04	.50						
-A05	.50	.50	.50	.50	.50	.50	.50
-A08	.50	.50	.50	.50	.50	.50	.50
-A10	.30	.40	.35	.50	.50	.50	.50
-A15		.40	.35	.50	.50	.50	.50
-A20				.50	.45	.50	.40
-B0Z	.50	.50	.50	.50	.50	.50	.50
-B06	.40	.50	.40	.50	.50	.50	.50
-B09		.50	.50	.50	.50	.50	.50
-B15		.35	.30	.50	.50	.50	.50
-B18				.50	.50	.50	.50
-C0Z	.50	.50	.50	.50	.50	.50	.50
-C06	.50	.50	.50				
-C09		.50	.40	.50	.50	.50	.50
-C15		.45	.35	.50	.50	.50	.50
-Q15				.50	.50	.50	.50

Values shown are for units equipped with standard 1" throwaway filter or 1" washable filter.
Derate ESP by .15 for 2" pleated filters.

RUNNING IN STAND ALONE (ORPHAN) MODE

With the AC breakers turned on, each MULTI-TEC wall-mount unit has the capability to run without the LC6000 controller attached—this feature is called stand alone or orphan mode. This keeps the shelter between 60°F and 77°F (factory default settings) by the use of the factory-installed return air sensor in each wall-mount unit. The blower runs continuously in stand alone mode.

The wall-mount unit can be turned on and off with the TEC-EYE™ hand-held diagnostic tool. When ON is chosen, the system will heat or cool. **NOTE:** *The blower will continue to run when OFF is chosen.* Refer to page 29 to change ON/OFF Control.

To change default setpoints, refer to **Setpoints: Local Cool and Heat/Current Cool and Heat** on page 25.

To change temperature differentials, refer to **Temperature Control** section on pages 29 and 30.

During installation, this allows deactivation of one of the two existing, older wall-mount units, while keeping the shelter cool with the other unit still operating. Once the first of the two Bard MULTI-TEC wall-mount units is installed, orphan mode can be enabled early in the installation—keeping the climate inside the shelter stable and the installers comfortable while the remainder of the older equipment is removed and the second Bard MULTI-TEC wall-mount unit and LC6000 controller are installed.

To ensure units will go into orphan mode, disconnect the plug marked R-T-/R+T+/GND on the wall-mount unit control board. Be sure to reconnect the plug before operating the wall-mount unit as part of the Bard Free Cooling Unit System.

Additionally, should either or both MULTI-TEC wall-mount units lose communication with the LC6000 controller (such as during maintenance), they will continue to serve the shelter's needs until a repair can be made.

See the LC6000 controller manual for information on connecting the communication wiring from the controller to the wall-mount units and operating the Bard Free Cooling Unit System.

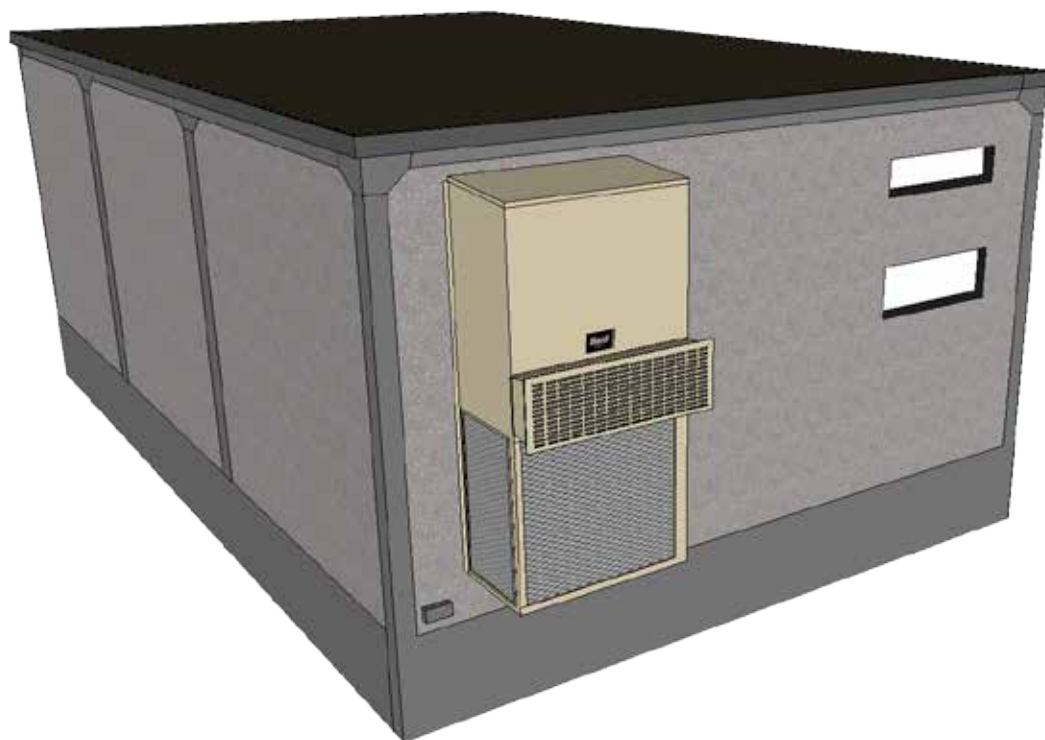

SECTION 2:

SERVICE

INSTRUCTIONS

USING THE TEC-EYE™

FIGURE 2.1
TEC-EYE™ (Bard P/N 8301-059) Display and Interface (Status Screen Shown)



ALARM KEY

Allows viewing of active alarms
Silences audible alarms
Resets active alarms

MENU KEY

Allows entry to Main Menu

BACK KEY

Returns to previous menu level
Cancels a changed entry

UP KEY

Steps to next screen in the display menu
Changes (increases) the value of a modifiable field

ENTER KEY

Accepts current value of a modifiable field
Advances cursor

DOWN KEY

Steps back to previous screen in the display menu
Changes (decreases) the value of a modifiable field

TEC-EYE™ HAND-HELD DIAGNOSTIC TOOL

The microprocessor control used in the MULTI-TEC wall-mount air conditioners allows for complete control and monitoring through the use of the provided TEC-EYE™ hand-held monitor. This comprehensive service tool utilizes the latest in state-of-the-art technology including a large, easy-to-read backlit LCD graphic display.

The menu driven interface provides users the ability to scroll through two menu levels: Quick Menu and Main Menu. The menus permit the user to easily view, control and configure the unit.

The controller is completely programmed at the factory; the default setpoints and their ranges are easily viewed and adjusted from the TEC-EYE™ display. The program and operating parameters are permanently stored on FLASH-MEMORY in case of power failure. The controller is designed to manage temperature levels to a user-defined setpoint via control output signals to the wall mount air conditioning system.

The TEC-EYE™ connects to the wall-mount unit control board via an RJ11 modular phone connector as shown in Figure 2.2.

FIGURE 2.2
TEC-EYE™ Connection to Unit Control

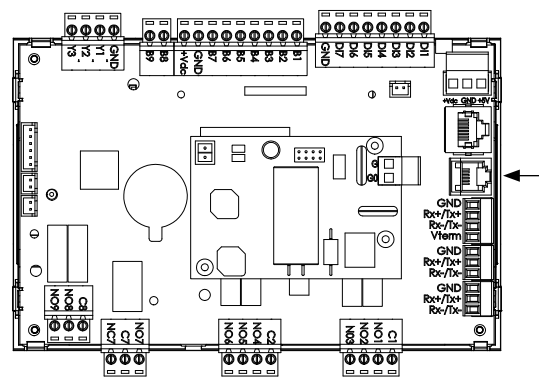

Modular Phone Connector for
TEC-EYE™ Hand-Held Diagnostic Tool

When not being used, the TEC-EYE™ hand-held diagnostic tool should be stored inside or near the LC6000 controller. Do not let the TEC-EYE™ leave the shelter.

TEC-EYE™ Menu Structure

Quick Menu

- Data Log
- Unit Information
- Setpoints

Main Menu

- System Configuration
- Advanced System Configuration
- I/O Configuration
- On/Off
- Alarm Logs
- Settings
- Logout

In addition to the menu structure above, there are also Status and Alarm screens.

TEC-EYE™ Acronyms

MAT – Mixed air temperature
RAT – Return air temperature
OAT – Outdoor air temperature
OAH – Outdoor air humidity
Blower – Indoor Blower Status
Damper – Free cooling damper position status
C1 – Compressor activate status
H1 – Heater Stage 1 status
H2 – Heater Stage 2 status
ODP – Calculated outdoor dew point
FC – Free cooling status
RN – Component run time in minutes in last hour
ST – Number of start requests in last hour

NOTE: *Digital refers to On/Off whereas analog is a variable input.*

Status Screen

The Status screen is the default start-up screen and also the return screen after 5 minutes of no activity. The screen can be accessed any time by pressing the BACK button repeatedly.

The wall-mount unit address is displayed in the upper right corner on the Status screen (see Figure 2.1). The Status screen also shows the current date, time, return air temperature, mixed air temperature, outdoor air temperature, outdoor humidity and outdoor dewpoint conditions. Blower, damper and unit status are also displayed.

The Quick Menu is accessible from the Status screen. Data Log, Unit Information and Setpoints are available through the Quick Menu. Pressing the UP or DOWN keys while on the Status screen will change the Quick Menu icon displayed (see Figure 2.3). Press the ENTER key when the desired icon is displayed.

FIGURE 2.3
Quick Menu Icons



Setpoints: Local Cool and Heat/Current Cool and Heat

If at any time the unit(s) loses communication with the LC6000 controller, the unit(s) will go to stand alone mode. Local cooling and heating setpoints only apply to stand alone mode. The Current cooling and heating setpoints are the setpoints for the on and off differential points.

The LC6000 setpoints will determine the Current cooling and heating setpoints when communicating. The Local cooling and heating setpoints will determine the Current cooling and heating setpoints when in stand alone mode.

To change local cool and heat setpoints:

1. From the Status screen, press UP or DOWN key until Quick Menu displays Setpoints icon. Press ENTER key.
2. Press ENTER key to scroll to the selected choice (see Figure 2.4).
3. Press UP or DOWN key on desired value until value displays correctly.
4. Press ENTER key to submit value and move to next parameter.
5. Press BACK key until Main Menu screen is displayed.

FIGURE 2.4
Local Cool/Heat and Current Cool/Heat Setpoints



Executing a Run Test

Execute a run test on each unit to verify the equipment is functioning correctly.

1. Press MENU key to access the Main Menu screen.
2. Press UP or DOWN keys and ENTER key to enter USER password 2000.

3. Press UP or DOWN keys to scroll to **Sys Config**; press ENTER key.
4. Press UP or DOWN keys to scroll to **Run Test (A10)** screen.
5. Press ENTER key to scroll to **Run Test Enable** parameter (see Figure 2.5).
6. Press UP or DOWN key to change value to ON. The run test will begin.

FIGURE 2.5
Executing Run Test

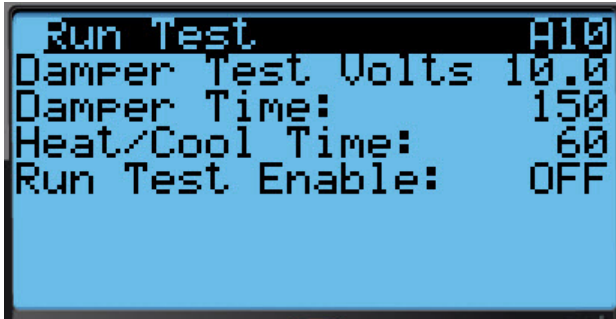

Run Test Approximate Timings (in Minutes)

- | | |
|------|---|
| 0:00 | <ul style="list-style-type: none"> • Blower starts • Damper begins to open to damper test volts parameter |
| 2:30 | <ul style="list-style-type: none"> • Damper begins to close to 0 volts |
| 5:00 | <ul style="list-style-type: none"> • Compressor turns on |
| 6:00 | <ul style="list-style-type: none"> • Compressor turns off • Heat turns on |
| 7:00 | <ul style="list-style-type: none"> • Heat turns off |
| 8:00 | <ul style="list-style-type: none"> • Blower turns off |

Parameter Description

Damper Test Volts: This is the control voltage applied to the actuator during opening sequence for damper.

Damper Time: This is the time (in seconds) allowed for both the opening sequence and closing sequence.

Heat/Cool Time: This is the time (in seconds) allowed for cooling sequence and heating sequence.

Identifying a Unit Address

The wall-mount unit address is displayed in the upper right corner on the Status screen.

Changing Freecooling Type

The comparative enthalpy free cooling setting can be changed to dry bulb free cooling using the TEC-EYE™ hand-held diagnostic tool.

1. Press MENU key to access the Main Menu screen.
2. Press UP or DOWN keys and ENTER key to enter USER password 2000.
3. Press UP or DOWN keys to scroll to **Sys Config**; press ENTER key.
4. Press UP or DOWN keys to scroll to screen with **Freecooling Config** heading.
5. Press ENTER key to scroll to parameter type.
6. Press UP or DOWN keys to change to desired value.
7. Press ENTER key to save.
8. Press BACK key until Main Menu screen is displayed.

Alarm Adjustment

Acknowledging/Clearing Alarms

Alarm conditions activate a red LED indicator that backlights the ALARM function key. As an option, an alarm condition may also be enunciated by an audible alarm signal. An alarm is acknowledged by pressing the ALARM key. This calls up alarm display screen(s) that provide a text message detailing the alarm condition(s). After an alarm condition is corrected, the alarm can be cleared by pressing the ALARM key for 3 seconds.

Mixed Air Alarm

The mixed air alarm is used to indicate proper operation of the economizer. An alarm will be generated when the mixed air temperature is above or below two independent setpoints.

This alarm can be adjusted by changing the alarm setpoints and/or delay. The differential low references the economizer control setpoint. For example, if the economizer setpoint is 55°F (as shown in Figure 2.15 on page 32) and the differential is set to 10, the lower limit for the mixed air alarm would be 45°F. The high differential references the outdoor air temperature setpoint that enables the economizer. For example, if the outdoor air temperature setpoint for economizer enable is set to 65°F and the high differential is set to 5 (as shown in Figure 2.13 on page 31), the alarm would actuate at 70°F. The alarm also has a delay to help reduce nuisance alarms. With the delay set to 10 seconds, either the high mixed air or low mixed air alarm will need to be active for 10 seconds before an alarm will be generated.

To adjust these values:

1. Press MENU key to go to the Main Menu screen.
2. Press UP or DOWN keys and ENTER key to enter USER password 2000.
3. Press UP or DOWN keys to scroll to **Sys Config**; press ENTER key.
4. Press UP or DOWN keys to scroll to **Alarm Config (A7)**; press ENTER key.
5. Press ENTER key to scroll to desired value **Diff Lo**, **Diff Hi** or **Del** (see Figure 2.6).
6. Press UP or DOWN keys to adjust value.
7. Press ENTER key to save.

FIGURE 2.6
Adjusting Mixed Air Alarm Values

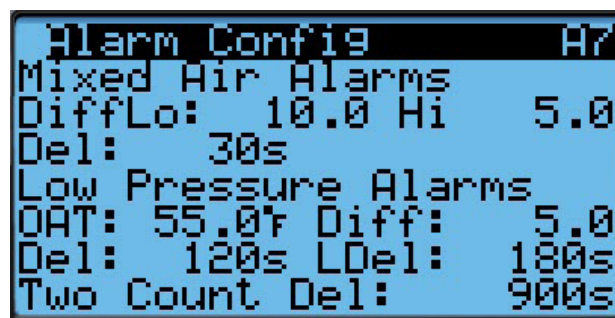

Refrigerant Low Pressure

When the low pressure switch indicates a low pressure condition and there is an active call for cooling, the controller will generate an alarm (after a delay). The delay used by the low pressure alarm is determined by the outdoor air temperature (OAT on display). If the outdoor air temperature is below 55°F, the delay is 180 seconds (Del on display). If the outdoor temperature is above 55°F, the delay is 120 seconds (LDel on display). The unit will also have an address-based delay that will affect start up time. The default is 5 seconds multiplied by unit address. Additionally, if the outdoor temperature sensor is not used, the delay is set to 180 seconds. The controller will try to run the refrigeration system two times before the alarm will lock the compressor out.

If 15 minutes (Two Count Del value on display) passes before the second attempt, the number of tries will be reset.

To adjust these values:

1. Press MENU key to go to the Main Menu screen.
2. Press UP or DOWN keys and ENTER key to enter USER password 2000.
3. Press UP or DOWN keys to scroll to **Sys Config**; press ENTER key.
4. Press UP or DOWN keys to scroll to **Alarm Config (A7)**; press ENTER key.
5. Press ENTER key to scroll to desired value **OAT**, **Diff**, **Del**, **LDel** or **Two Count Del** (see Figure 2.6).
6. Press UP or DOWN keys to adjust value.
7. Press ENTER key to save.

Refrigerant High Pressure

When the wall unit receives a signal from the compressor control module (CCM) indicating a high pressure event, the wall unit will generate an alarm.

Upon receiving the alarm, the wall unit will remove the “Y” call from the CCM, resetting the status of the CCM. The alarm will stay present on the wall unit until manually cleared. This operation has no configurable parameters.

Economizer Damper

When the controller commands the economizer damper actuator to a position other than 0% and the damper switch indicates the damper is not open, after a delay of 20 seconds (Open Del on display) the controller will generate a damper failed to open alarm. When the controller commands the economizer damper actuator to the 0% position and the damper switch indicates the damper is not closed, after a delay of 300 seconds (Close Del on display) the controller will generate a damper failed to close alarm.

To adjust these values:

1. Press MENU key to go to the Main Menu screen.
2. Press UP or DOWN keys and ENTER key to enter USER password 2000.
3. Press UP or DOWN keys to scroll to **Sys Config**; press ENTER key.
4. Press UP or DOWN keys to scroll to **Alarm Config (A8)**; press ENTER key.
5. Press ENTER key to scroll to desired value **Open Del** or **Close Del** (see Figure 2.7).
6. Press UP or DOWN keys to adjust value.
7. Press ENTER key to save.

Freezestat

When the coil temperature is below 30°F, the unit will generate a Freeze alarm on the TEC-EYE™ and a Freeze Temp alarm on the LC6000. This will operate the blower and turn off the compressor.

When the coil temp is above 55°F, the alarm must be reset with the TEC-EYE™ at the unit. This will clear the alarm at the LC6000 as well. The blower and compressor will then be available to operate as needed for cooling.

To adjust freezestat values:

1. Press MENU key to go to the Main Menu screen.
2. Press UP or DOWN keys and ENTER key to enter USER password 2000.
3. Press UP or DOWN keys to scroll to **Sys Config**; press ENTER key.
4. Press UP or DOWN keys to scroll to **Alarm Config (A8)**; press ENTER key.
5. Press ENTER key to scroll to desired value **Low Temp**, **Reset Temp** or **Reset Del** (see Figure 2.7).
6. Press UP or DOWN keys to adjust value.
7. Press ENTER key to save.

FIGURE 2.7
Adjusting Damper Alarm Values

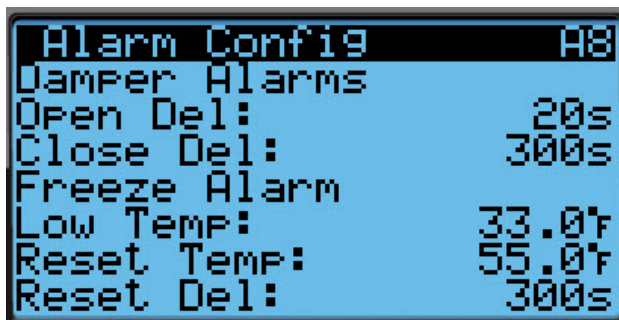

CONTROL OPERATION

On/Off Control

The wall unit can be turned on and off with the TEC-EYE™. When the unit is set to ON, the system will heat and cool the space either in standalone mode or when connected to the LC. When the unit is set to OFF, the unit will not heat or cool the space. **NOTE:** *The blower may continue to run in standalone or when connected to LC.*

To turn the unit on or off:

1. Press MENU key to go to the Main Menu screen.
2. Press UP or DOWN keys and ENTER key to enter USER password 2000.
3. Press UP or DOWN keys to scroll to **ON/OFF**; press ENTER key.
4. Press UP or DOWN key to change the system from OFF to ON or from ON to OFF.
5. Press BACK key until Main Menu screen is displayed.

Fan Control

The blower will be in continuous operation in stand alone mode. To operate the blower continuously while communicating with the LC6000, refer to LC6000 manual.

Temperature Control

Zone Selection

Any zone selected has a control value that is determined by averaging the remote temperature sensor and/or temperature/humidity sensor and the return air sensors of all wall-mount units in this zone (see Figure 2.8).

FIGURE 2.8
LC6000 Status Screen Showing Control Values



The control value is used by the LC6000 to signal a need for cooling to the wall-mount units.

Cooling Sequence – Economizer Available (see Figure 2.9)

If the control value is higher than 79°F (Setpoint + Stage 1 Diff On) and outdoor conditions are acceptable for economizing, the unit will enable the economizer. If the control value is higher than 80°F (Setpoint + Stage 2 Diff On), the unit will enable mechanical cooling stage 1. If the control value is higher than 81°F (Setpoint + Stage 3 Diff On), the unit will enable mechanical cooling stage 2.

Cooling Sequence – Economizer Not Available (see Figure 2.9)

If the control value is higher than 79°F (Setpoint + Stage 1 Diff On), the unit will enable stage 1 mechanical cooling. If the control value is higher than 80°F (Setpoint + Stage 2 Diff On), the unit will enable stage 2 mechanical cooling.

FIGURE 2.9
MULTI-TEC Wall-Mount Unit Cooling Staging

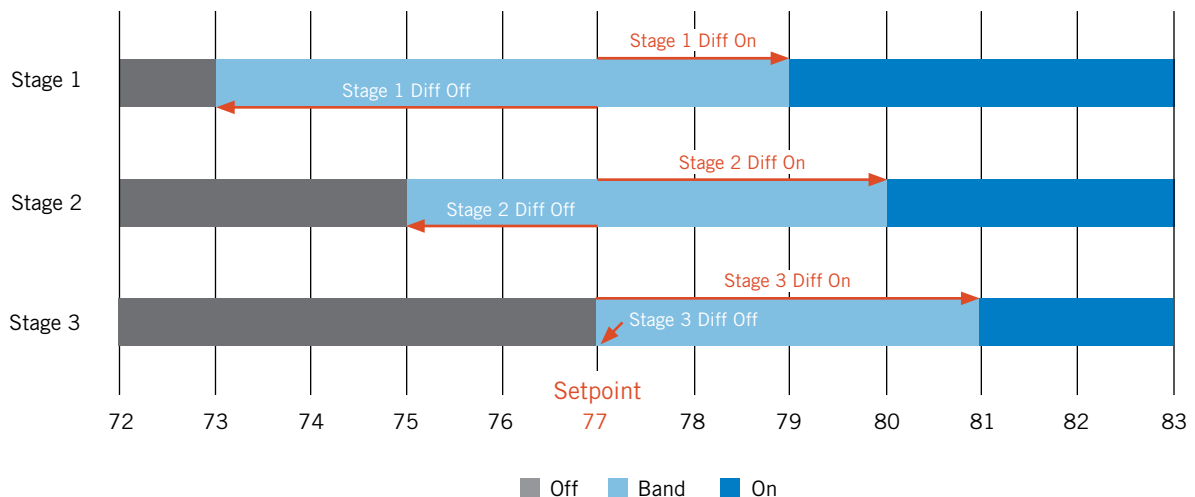

To adjust these parameters:

1. Press MENU key to go to the Main Menu screen.
2. Press UP or DOWN keys and ENTER key to enter USER password 2000.
3. Press UP or DOWN keys to scroll to **Sys Config**; press ENTER key.
4. Press UP or DOWN keys to scroll to **Cooling Setup (A2)**; press ENTER key.
5. Press ENTER key to scroll to **Stage 1 Diff On, Stage 1 Diff Off, Stage 2 Diff On, Stage 2 Diff Off, Stage 3 Diff On or Stage 3 Diff Off** (see Figure 2.10).
6. Press UP or DOWN keys to adjust value.
7. Press ENTER key to save.

FIGURE 2.10
Adjusting Cooling Differential Values

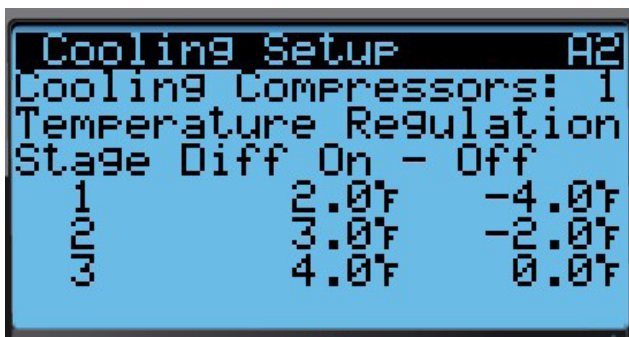

If the control value is below 56°F (Setpoint + Stage 3 Diff On), the unit will enable electric heat stage 3.

To adjust these parameters:

1. Press MENU key to go to the Main Menu screen.
2. Press UP or DOWN keys and ENTER key to enter USER password 2000.
3. Press UP or DOWN keys to scroll to **Sys Config**; press ENTER key.
4. Press UP or DOWN keys to scroll to **Heating Setup (A3)**; press ENTER key.
5. Press ENTER key to scroll to **Stage 1 Diff On, Stage 1 Diff Off, Stage 2 Diff On, Stage 2 Diff Off, Stage 3 Diff On or Stage 3 Diff Off** (see Figure 2.11).
6. Press UP or DOWN keys to adjust value.
7. Press ENTER key to save.

FIGURE 2.11
Adjusting Heating Differential Values

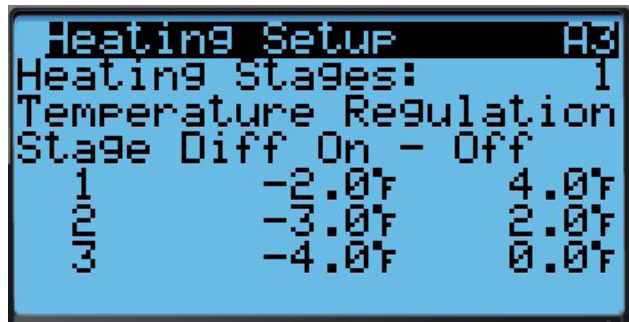

Heating Sequence (see Figure 2.12)

If the control value is below 58°F (Setpoint + Stage 1 Diff On), the unit will enable electric heat stage 1.
 If the control value is below 57°F (Setpoint + Stage 2 Diff On), the unit will enable electric heat stage 2.
 If the control value is below 56°F (Setpoint + Stage 3 Diff On), the unit will enable electric heat stage 3.

FIGURE 2.12
MULTI-TEC Wall-Mount Unit Heating Staging

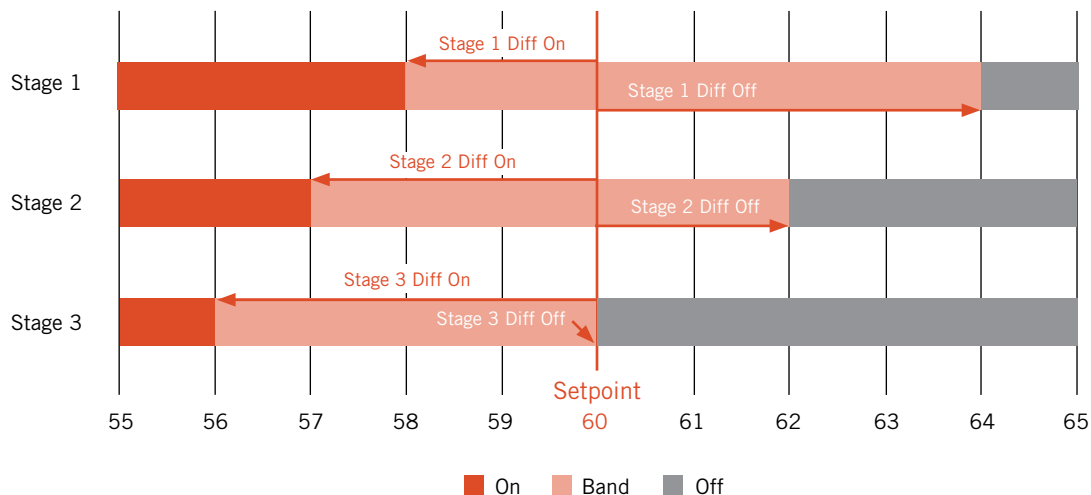

Freecooling

Economizer Enable

The model number is used to determine if an economizer is installed. If an economizer is not installed, this feature will be disabled and sensors will be turned off that are not installed.

The economizer will be enabled for cooling operation if the following conditions are true: (screens available through **Sys Config** in Main Menu)

To navigate to the **Economizer A4** screen (Figure 2.13) and **Economizer A5** screen (Figure 2.14):

1. Press MENU key to go to the Main Menu screen.
2. Press UP or DOWN keys and ENTER key to enter USER password 2000.
3. Press UP or DOWN keys to scroll to **Sys Config**; press ENTER key.
4. Press UP or DOWN keys to scroll to **Economizer (A4)** or **Economizer (A5)**; press ENTER key.
5. Press ENTER key to scroll to **Type**.
6. Press UP or DOWN keys to change **Type** to **Drybulb, Temperature and Humidity** or **Enthalpy**.
7. To change the outdoor setpoint for economizer operation, press ENTER key to scroll to **Outdoor Set**.
8. Press UP or DOWN keys to change the temperature to the desired value.
9. Press ENTER key to scroll to **On Diff**.
10. Press UP or DOWN keys to adjust value. **NOTE:** *This value is the differential on for the outdoor setpoint. This value is how many degrees above the setpoint that the economizer will be enabled when the economizer is disabled. The outdoor setpoint is when the economizer will be disabled when the economizer is active.*
11. Press ENTER key to scroll to **OA Humid Set**.
12. Press UP or DOWN keys to adjust value.
13. Press ENTER key to scroll to **OA Dew Pt Set**.
14. Press UP or DOWN keys to adjust value.
15. Press ENTER key to scroll to **On Diff**.
16. Press UP or DOWN keys to adjust value. **NOTE:** *This value is the differential on for the outdoor air dewpoint setpoint. This value is how many degrees above the setpoint that the economizer will be enabled when economizer is disabled. The outdoor air dewpoint setpoint is when the economizer will be disabled when the economizer is active.*
17. Press ENTER key to scroll to **Dewpoint Delay**.
18. Press UP or DOWN keys to adjust value. **NOTE:** *This is a delay before the economizer will be enabled based on dewopint. This time must expire*

FIGURE 2.13
Economizer A4 Screen

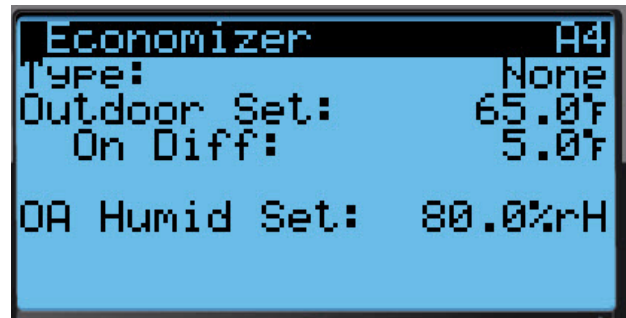
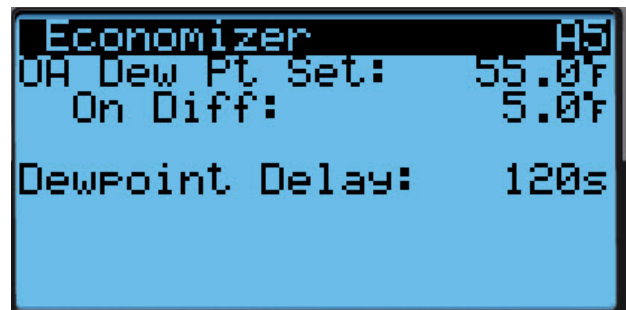

FIGURE 2.14
Economizer A5 Screen



and the dewpoint must be above the setpoint plus on differential value for the dewpoint portion of economizer to be approved.

None

Economizer will not be enabled.

Drybulb Only

1. Outdoor air temperature is below 70°F (Outdoor Set on display). See Figure 2.13.
2. LC6000 is not currently in Dehum Mode.

Temperature and Humidity (Default)

1. Outdoor air temperature is below 70°F (Outdoor Set on display).
2. Outdoor relative humidity is below 60% (OA Humid Set on display) without LC indoor zone humidity sensor or 80% (OA Humid Set on display) with LC indoor humidity sensor (see Figure 2.13).
3. LC6000 is not currently in Dehum Mode.

Enthalpy (Temperature, Humidity and Dewpoint)

1. Outdoor air temperature is below 70°F (Outdoor Set on display).
2. Outdoor relative humidity is below 60% (OA Humid Set on display) without LC indoor humidity sensor or 80% (OA Humid Set on display) with LC indoor humidity sensor (see Figure 2.13).

3. The outdoor air dewpoint is less than 60°F (OA Dew Pt Set on display). See Figure 2.14.
4. LC6000 is not currently in Dehum Mode.

Economizer Modulation

The economizer damper output will modulate between 0% and 100% to maintain a 55°F mixed air temperature when the outdoor air conditions are acceptable.

To adjust damper modulation values:

1. Press MENU key to go to the Main Menu screen.
2. Press UP or DOWN keys and ENTER key to enter USER password 2000.
3. Press UP or DOWN keys to scroll to **Sys Config**; press ENTER key.
4. Press UP or DOWN keys to scroll to **Unit Config (A6)**; press ENTER key.
5. Press ENTER key to scroll to **Mixed FC Set, Gain, Integral** or **Derivative** (see Figure 2.15).
6. Press UP or DOWN keys to adjust parameter value.
7. Press ENTER key to save.

FIGURE 2.15
Adjusting Damper Modulation Values

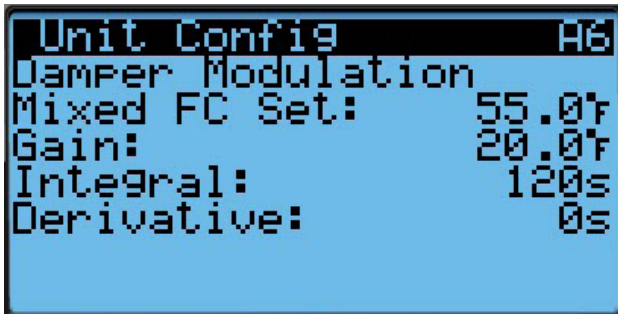

Economizer Note

The economizer and mechanical cooling can operate simultaneously because the economizer uses the mixed air temperature sensor.

Compressor

Enable

The compressor will be enabled when stage 1 is enabled and outdoor air conditions are not acceptable for economizing. If the conditions are acceptable, the compressor will run when stage 2 is enabled.

Delays and Run Time

The compressor will have a minimum run time of 180 seconds and a minimum off time of 120 seconds. If the compressor is two stage, the second stage will have a minimum delay of 120 seconds. The 2nd stage will also have a minimum on time of 120 seconds. Each wall unit will have a delay based on the address so that the compressors on each unit will start at different times if a call to all units is given. This will prevent large in rush current from occurring. This delay is 5 seconds times the unit address. Example: 5 seconds x unit 6 = 30 seconds.

FIGURE 2.16
Wall-Mount Unit Control Board

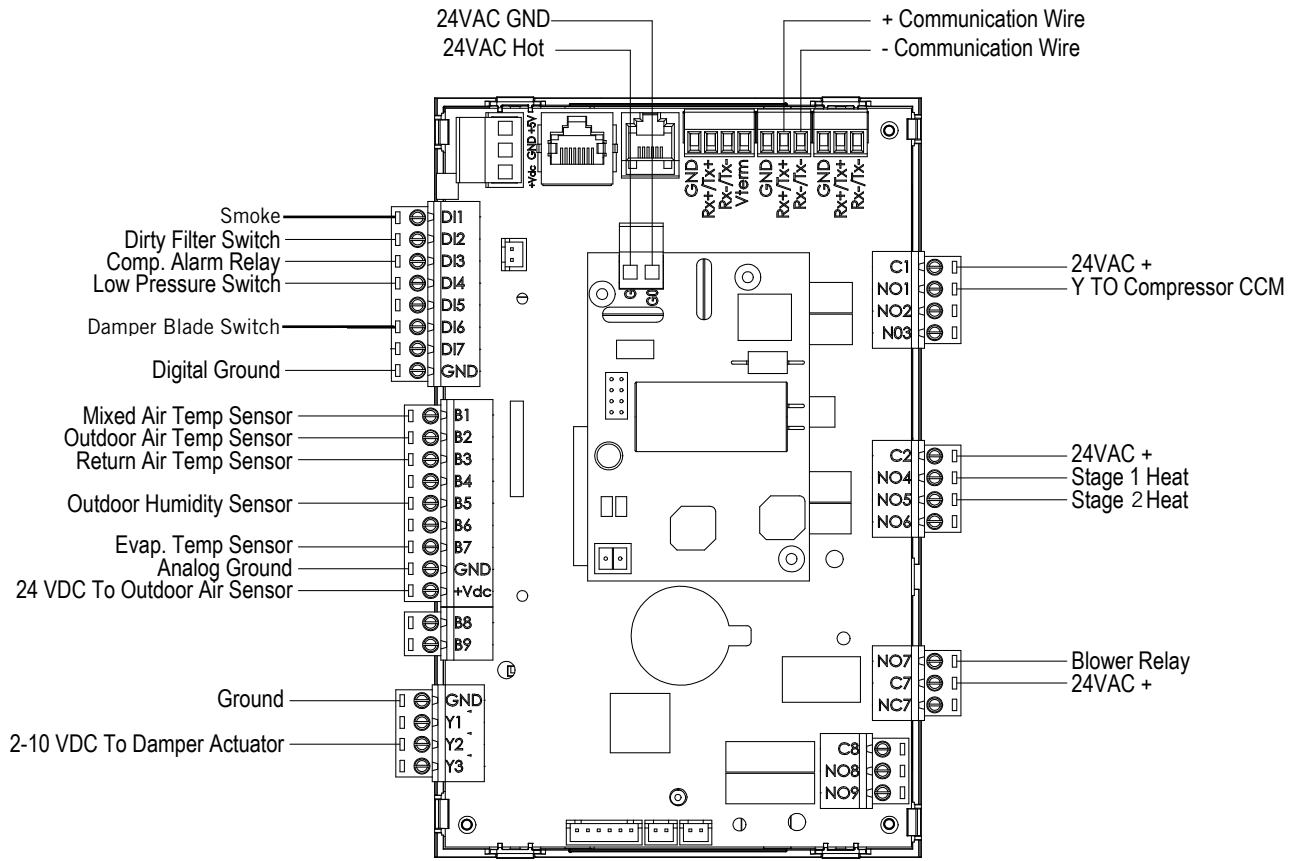

MIS-3869

GENERAL REFRIGERANT INFORMATION

NOTICE

These units require R-410A refrigerant and polyol ester oil.

GENERAL

1. Use separate service equipment to avoid cross contamination of oil and refrigerants.
2. Use recovery equipment rated for R-410A refrigerant.
3. Use manifold gauges rated for R-410A (800 psi/250 psi low).
4. R-410A is a binary blend of HFC-32 and HFC-125.
5. R-410A is nearly azeotropic—similar to R-22 and R-12. Although nearly azeotropic, charge with liquid refrigerant.
6. R-410A operates at 40-70% higher pressure than R-22, and systems designed for R-22 cannot withstand this higher pressure.
7. R-410A has an ozone depletion potential of zero, but must be reclaimed due to its global warming potential.
8. R-410A compressors use polyol ester oil.
9. Polyol ester oil is hygroscopic; it will rapidly absorb moisture and strongly hold this moisture in the oil.
10. A liquid line dryer must be used—even a deep vacuum will not separate moisture from the oil.
11. Limit atmospheric exposure to 15 minutes.
12. If compressor removal is necessary, always plug compressor immediately after removal. Purge with small amount of nitrogen when inserting plugs.

TOPPING OFF SYSTEM CHARGE

If a leak has occurred in the system, Bard Manufacturing recommends reclaiming, evacuating (see criteria above) and charging to the nameplate charge. If done correctly, topping off the system charge can be done without problems.

With R-410A, there are no significant changes in the refrigerant composition during multiple leaks and recharges. R-410A refrigerant is close to being an azeotropic blend (it behaves like a pure compound or single component refrigerant). The remaining refrigerant charge in the system may be used after leaks have occurred. “Top-off” the charge by utilizing the pressure charts on the inner control panel cover as a guideline.

REMEMBER: When adding R-410A refrigerant, it must come out of the charging cylinder/tank as a liquid to avoid any fractionation and to insure optimal system performance. Refer to instructions for the cylinder that is being utilized for proper method of liquid extraction.

SAFETY PRACTICES

1. Never mix R-410A with other refrigerants.
2. Use gloves and safety glasses. Polyol ester oils can be irritating to the skin, and liquid refrigerant will freeze the skin.
3. Never use air and R-410A to leak check; the mixture may become flammable.
4. Do not inhale R-410A—the vapor attacks the nervous system, creating dizziness, loss of coordination and slurred speech. Cardiac irregularities, unconsciousness and ultimately death can result from breathing this concentration.
5. Do not burn R-410A. This decomposition produces hazardous vapors. Evacuate the area if exposed.
6. Use only cylinders rated DOT4BA/4BW 400.
7. Never fill cylinders over 80% of total capacity.
8. Store cylinders in a cool area, out of direct sunlight.
9. Never heat cylinders above 125°F.
10. Never trap liquid R-410A in manifold sets, gauge lines or cylinders. R-410A expands significantly at warmer temperatures. Once a cylinder or line is full of liquid, any further rise in temperature will cause it to burst.

IMPORTANT INSTALLER NOTE

For improved start up performance, wash the indoor coil with a dishwashing detergent.

R410-A REFRIGERANT CHARGE

This unit was charged at the factory with the quantity of refrigerant listed on the serial plate. AHRI capacity and efficiency ratings were determined by testing with this refrigerant charge quantity.

The pressure table found on page 35 shows nominal pressures for the units. Since many installation specific situations can affect the pressure readings, this information should only be used by certified technicians as a guide for evaluating proper system performance. They shall not be used to adjust charge. If charge is in doubt, reclaim, evacuate and recharge the unit to the serial plate charge.

TABLE 2.1
Cooling Pressures

Air Temperature Entering Outdoor Coil °F

Model	Return Air Temp (DB/WB)	Pressure	75	80	85	90	95	100	105	110	115	120	125
W18A/L*P	75/62	Low Side High Side	121 293	123 312	126 332	128 353	131 376	134 400	136 425	137 452	140 480	142 510	144 540
	80/67	Low Side High Side	129 300	132 320	135 340	137 362	140 386	143 410	145 436	147 464	150 492	152 523	154 554
	85/72	Low Side High Side	134 311	137 331	140 352	142 375	145 400	148 424	150 451	152 480	155 509	157 541	159 573
W24A/L*P	75/62	Low Side High Side	123 314	124 334	126 355	128 377	129 401	131 425	133 451	135 479	137 507	139 536	141 567
	80/67	Low Side High Side	132 322	133 343	135 364	137 387	138 411	140 436	142 463	144 491	146 520	149 550	151 582
	85/72	Low Side High Side	137 333	138 355	140 377	142 401	143 425	145 451	147 479	149 508	151 538	154 569	156 602
W30A/L*P	75/62	Low Side High Side	118 312	120 333	122 355	124 378	126 403	128 428	131 454	133 483	135 511	137 540	138 570
	80/67	Low Side High Side	126 320	128 342	131 364	133 388	135 413	137 439	140 466	142 495	144 524	146 554	148 585
	85/72	Low Side High Side	130 331	132 354	136 377	138 402	140 427	142 454	145 482	147 512	149 542	151 573	153 605
W36A/L*P	75/62	Low Side High Side	117 323	120 346	122 370	124 394	127 419	129 446	131 473	134 500	136 528	137 558	138 587
	80/67	Low Side High Side	125 331	128 355	130 379	133 404	136 430	138 457	140 485	143 513	145 542	147 572	148 602
	85/72	Low Side High Side	129 343	132 367	135 392	138 418	141 445	143 473	145 502	148 531	150 561	152 592	153 623
W42A/L*P	75/62	Low Side High Side	123 323	125 346	128 371	130 395	132 421	135 447	137 474	138 501	140 528	142 558	144 587
	80/67	Low Side High Side	132 331	134 355	137 380	139 405	141 432	144 458	146 486	148 514	150 542	152 572	154 602
	85/72	Low Side High Side	137 343	139 367	142 393	144 419	146 447	149 474	151 503	153 532	155 561	157 592	159 623
W48A/L*P	75/62	Low Side High Side	120 330	122 353	125 377	127 402	130 428	132 454	134 482	136 510	137 540	139 570	141 601
	80/67	Low Side High Side	128 338	131 362	134 387	136 412	139 439	141 466	143 494	145 523	147 554	149 585	151 616
	85/72	Low Side High Side	132 350	136 375	139 401	141 426	144 454	146 482	148 511	150 541	152 573	154 605	156 638
W60A/L*P	75/62	Low Side High Side	127 344	129 362	131 380	134 401	136 421	137 444	140 467	142 492	145 518	148 545	151 573
	80/67	Low Side High Side	136 353	138 371	140 390	143 411	145 432	147 455	150 479	152 505	155 531	158 559	161 588
	85/72	Low Side High Side	141 365	143 384	145 404	148 425	150 447	152 471	155 496	157 523	160 550	164 579	167 609
W72A/L*P	75/62	Low Side High Side	117 332	119 353	121 376	122 402	124 427	126 454	128 483	130 512	132 542	134 574	136 607
	80/67	Low Side High Side	125 340	127 362	129 386	131 412	133 438	135 466	137 495	139 525	141 556	143 589	145 623
	85/72	Low Side High Side	129 352	131 375	134 400	136 426	138 453	140 482	142 512	144 543	146 575	148 610	150 645

Low side pressure ± 4 PSIG
High side pressure ± 10 PSIG

Tables are based upon rated CFM (airflow) across the evaporator coil. If there is any doubt as to correct operating charge being in the system, the charge should be removed and system evacuated and recharged to serial plate charge weight.

NOTE: Pressure table based on high speed condenser fan operation. If condensing pressures appear elevated check condenser fan wiring. See "Condenser Fan Operation".

COMPONENTRY

WARNING

Electrical shock hazard.

Disconnect VAC power supply before servicing.

Failure to do so could result in electric shock or death.

HIGH PRESSURE SWITCH

All W**A/W**L wall-mount air conditioner series models are supplied with a remote reset for the high pressure switch. If tripped, the pressure switch may be reset by turning the output off then back on again.

THREE PHASE SCROLL COMPRESSOR START UP INFORMATION

Scroll compressors, like several other types of compressors, will only compress in one rotational direction. Direction of rotation is not an issue with single phase compressors since they will always start and run in the proper direction.

However, three phase compressors will rotate in either direction depending upon phasing of the power. Since there is a 50-50 chance of connecting power in such a way as to cause rotation in the reverse direction, verification of proper rotation must be made. Verification of proper rotation direction is made by observing that suction pressure drops and discharge pressure rises when the compressor is energized. Reverse rotation also results in an elevated sound level over that with correct rotation, as well as substantially reduced current draw compared to tabulated values.

Verification of **proper rotation** must be made at the time the equipment is put into service. If improper rotation is corrected at this time, there will be no negative impact on the durability of the compressor. However, reverse operation for over 1 hour may have a negative impact on the bearing due to oil pump out.

NOTE: *If compressor is allowed to run in reverse rotation for an extended period of time, the compressor's internal protector will trip.*

All three phase compressors are wired identically internally. As a result, once the correct phasing is determined for a specific system or installation, connecting properly phased power leads to the same Fusite terminal should maintain proper rotation direction.

The direction of rotation of the compressor may be changed by reversing any two line connections to the unit.

PHASE MONITOR

Used only on 3-phase equipment, the phase monitor is a compressor protection device that will prohibit operation of the compressor if the device senses a possible reverse-rotation situation due to incorrect phasing. On a call for compressor (and only compressor), the device will check incoming phase, check for severe voltage imbalance and check for proper frequency. Under nominal conditions, a green LED light will show on the face of the monitor. If there is improper phasing, voltage imbalance or frequency deviation, the device will show a red LED light and prohibit compressor operation.

If a fault condition occurs, reverse two of the supply leads to the unit. **Do not reverse any of the unit factory wires as damage may occur.**

CONDENSER FAN OPERATION

NOTE: *On models equipped with a low ambient control (LAC), the condenser fan motor will have a delayed start until system refrigerant operating pressure builds up. After starting, the fan motor may or may not cycle depending upon ambient conditions. This is normal operation.*

The condenser fan motor on 230/208 volt, one and three phase, 60 HZ units is a two-speed motor that comes factory wired on high speed for peak performance. If ambient conditions permit, it can be reconnected to low speed (red wire) for lower sound level. See unit wiring diagram. (*This applies to W42, W48, W60 and W72 models only.*)

LOW AMBIENT CONTROL

Modulating head-pressure control that allows full speed at pressures above 315psi. Below 315psi, the control will slow fan speed—following internal head pressures—until a minimum RPM is reached (approx 300 RPM). Below this point, the control will shut the fan completely off until internal pressures rise. The control is preset from the factory, but should adjustment become necessary, there is an adjustment screw located on the bottom of the control behind a weatherproof cap. One full turn clockwise equals approximately +48 psi.

COMPRESSOR CONTROL MODULE

Compressor protection device that has an adjustable 30-second to 5-minute timer (red-dial). This module features a delay-on-make for initial start-up (or anytime power is interrupted) for a minum 2 minutes plus 10% of the red-dial setting. There is no delay during

routine operation of the unit. The compressor control module (CCM) also monitors the high pressure switch, and will allow one automatic retry (after soft lockout delay) before disabling the compressor in a hard lockout (requires manual reset). If hard lockout does occur, the ALR terminal on the CCM will become active with 24V, which will power the high pressure relay within the wall-mount unit, breaking a digital input to the LC6000 controller—signaling a high-pressure situation to the system.

PRESSURE SERVICE PORTS

High and low pressure service ports are installed on all units so that the system operating pressures can be observed. A pressure table covering all models can be found on page 35. It is imperative to match the correct pressure table to the unit by model number.

This unit employs high-flow Coremax valves instead of the typical Schrader type valves.

WARNING! Do NOT use a Schrader valve core removal tool with these valves. Use of such a tool could result in eye injuries or refrigerant burns!

To change a Coremax valve without first removing the refrigerant, a special tool is required which can be obtained at www.fastestinc.com/en/SCCA07H. See the replacement parts manual for replacement core part numbers.

OUTDOOR FAN MOTOR

Due to design considerations of the condenser section of the wall-mount unit, placement/clearance of the motor/fan blade is critical to heat dispersal. Should a change of motor or fan blade be necessary, please view Figure 2.17 for proper clearance adjustment.

FIGURE 2.17
Fan Blade Setting

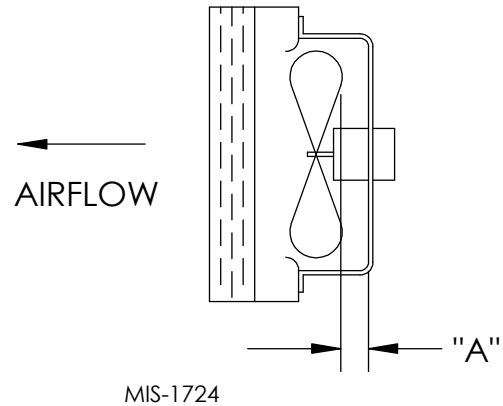

Model	Dimension A
W18AAP/W18LAP W24AAP/W24LAP	1.00"
W30AAP/W30LAP W36AAP/W36LAP	1.25"
W42AAP/W42LAP W48AAP/W48LAP W60AAP/W60LAP W72AAP/W72LAP	1.75"

TABLE 2.2A
Optional Accessories – Right Hand

	W18AAPA	W24AAPA	W24AAPB	W24AAPC	W30AAPA	W30AAPB	W30AAPC	W36AAPA	W36AAPB	W36AAPC	W42AAPA	W42AAPB	W42AAPC	W48AAPA	W48AAPB	W48AAPC	W60AAPA	W60AAPB	W60AAPC	W72AAPA	W72AAPB	W72AAPC	
Heater Kits	EHW2TA-A05	X	X																				
	EHW2TA-A08	X	X																				
	EHW2TA-A10	X	X																				
	EHWA24-A04B		X																				
	EHW2TA-B06			X																			
	EHWH24B-C06				X																		
	EHW3TA-A05					X			X														
	EHW3TA-A08					X			X														
	EHW3TA-A10					X			X														
	EHW3TA-A15					X			X														
	EHW30A-B06						X																
	EHW3TA-B06									X													
	EHW3TA-B09						X			X													
	EHW3TA-B15						X			X													
	EHW3TA-C06							X			X												
	EHW3TA-C09							X			X												
	EHW3TA-C12							X			X												
	EHW3TA-C15							X			X												
	EHW4TA-A05											X			X								
	EHWA05-A10B											X			X			X					
	EHWA05-A15B											X			X			X					
	EHWA05-A20B											X			X			X					
	EHW4TA-B06												X			X			X				
	EHWA05-B09B												X			X							
	EHW6TA-B06																						X
	EHWA05-B15B												X			X			X				X
	EHW5TA-B18																		X				
	EHW4TA-B18												X			X							
	EHW4TA-C09													X			X			X			X
	EHW4TA-C15													X			X			X			X
	EHW5TA-A05																	X			X		
	EHW60A-B09B																		X				
	EHW70A-B09B																						X
EHW6TA-B18																						X	
EHW72A-A10B																					X		
EHW72A-A15B																					X		
EHW72A-A20B																					X		
Circuit Breaker (WMCB) and Toggle Disconnect (WMPD)	WMCB-01B			X																			
	WMCB-02A	X																					
	WMCB-02B					X																	
	WMCB-03A		X																				
	WMCB-04B						X																
	WMCB-05A					X		X															
	WMCB-05B										X				X								
	WMCB-06B																	X					
	WMCB-08A											X			X								
	WMCB-09A																	X			X		
	WMPD-01C				X		X		X		X			X		X		X		X			X
	WMCB-08B																					X	

TABLE 2.2B
Optional Accessories – Left Hand

	W18LAPA	W24LAPA	W24LAPB	W30LAPA	W30LAPB	W30LAPC	W36LAPA	W36LAPB	W36LAPC	W42LAPA	W42LAPB	W42LAPC	W48LAPA	W48LAPB	W48LAPC	W60LAPA	W60LAPB	W60LAPC	W72LAPA	W72LAPB	W72LAPC	
Heater Kits	EHW2TA-A05L	X	X																			
	EHW2TA-A08L	X	X																			
	EHW2TA-A10L	X	X																			
	EHW2TA-B06L			X																		
	EHW3TA-A05L				X		X															
	EHW3TA-A08L				X																	
	EHW3TA-A10L				X		X															
	EHW3TA-A15L				X		X															
	EHW3TA-B09L					X		X														
	EHW3TA-B15L					X		X														
	EHW3TA-C09L						X		X													
	EHW3TA-C15L						X		X													
	EHW4TA-A05L										X			X			X					
	EHWA05-A10LB										X			X			X					
	EHWA05-A15LB										X			X			X					
	EHW4TA-B06L											X			X			X				
	EHWA05-B09LB											X			X							
	EHW6TA-B06L																					X
	EHWA05-B15LB											X			X			X				X
	EHW4TA-C09L												X			X			X			X
	EHW4TA-C15L												X			X			X			X
	EHW6TA-A05L																				X	
	EHWA60-B09LB																	X				
	EHW70A-B09LB																					X
EHW72A-A10LB																				X		
EHW72A-A15LB																				X		
Circuit Breaker (WMCB) and Toggle Disconnect (WMPD)	WMCB-01B			X																		
	WMCB-02A	X																				
	WMCB-02B					X																
	WMCB-03A		X																			
	WMCB-04B							X														
	WMCB-05A				X		X															
	WMCB-05B										X			X								
	WMCB-06B																	X				
	WMCB-08A										X			X								
	WMCB-09A															X			X			
	WMPD-01C						X		X			X			X			X				X
WMCB-09B																				X		

MAINTENANCE AND TROUBLESHOOTING

STANDARD MAINTENANCE PROCEDURES

WARNING

Electrical shock hazard.

Disconnect all power supplies before servicing.

Failure to do so could result in electric shock or death.

CAUTION

Cut hazard.

Wear gloves to avoid contact with sharp edges.

Failure to do so could result in personal injury.

1. Disable system from LC6000 controller (see controller manual).
2. Turn off AC breakers at wall-mount units.
3. Check inlet sides of condenser and evaporator coils for obstructions/debris—clean if necessary using a quality manufactured coil cleaning product specific for the evaporator or condenser coil.
 - Condenser coil: Remove the fan shroud/motor/motor bracket as an assembly from the condenser section. This will give clear access to the inlet side of the coil for cleaning. Follow the coil cleaner manufacturer's directions for necessary safety gear and precautions, as well as for application and use. More than one application may be necessary. Rinse thoroughly.
 - Evaporator coil: Remove the evaporator section panel and apply specific evaporator cleaner directly to the inlet side of coil, being very careful not to overspray into insulation or surrounding panels and wiring. Residual cleaner and dissolved debris should drip into the drain pan and leave the unit through the condensate hose. More than one application may be necessary. Rinse thoroughly.
4. Manually spin fan and blower motors to ensure they turn freely. All motors are permanently lubricated, so no oil is necessary.
5. Inspect free cooling damper actuator and linkage.
6. Install new air filter; check for additional filter grilles internal to the structure.
7. Inspect the control panel of the system.
 - Look for insect or rodent activity and remove any nesting materials.
 - Manually push contactor closed, observe for movement—contactor points should have minimal discoloration, no spalling or other signs of arcing. Replace if doubtful.
 - Check field and factory wiring for tightness and look for signs of overheating (discoloration of terminals or wire insulation).
8. Ensure that supply and return registers are not obstructed, and more importantly, are not recycling the air to one another. Adjust supply louvers if necessary to direct discharge air away from any direct route to the return grille.
9. Re-assemble wall-mount unit, turn breakers back on.
10. Enable system to LC6000 controller (see controller manual).
11. Repeat steps for additional wall-mount units.

REMOVAL OF FAN SHROUD

1. Disconnect all power to the unit.
2. Remove the screws holding both grilles, one on each side of unit, and remove grilles.
3. Remove nine screws holding fan shroud to condenser and bottom.
4. Unwire condenser fan motor.
5. Slide complete motor, fan blade and shroud assembly out the left side of the unit.
6. Service motor/fan as needed. Any service work requiring removal or adjustment in the fan and/or motor will require that the dimensions be checked and blade adjusted in or out on the motor shaft accordingly (see page 37 for proper clearance adjustment).
7. Reverse steps to re-install.

TROUBLESHOOTING MULTI-TEC WALL-MOUNT UNIT ALARMS

In the event that a problem is encountered with a wall-mount unit, the TEC-EYE™ hand-held tool may be used to diagnose the cause. If the problem can't be resolved using these guidelines, contact the BARD Technical Service Department at 419.636.0439 for assistance.

Signal	Description	Possible Cause	Component to Check	Recommended Action	Device Actions
Low Pressure Alarm	Alarm is activated when a low pressure event is present in the refrigeration system and the compressor is running.	Lack of refrigerant	Run the unit and check if the low pressure value is in the normal range.	Charge appropriate amount of refrigeration.	Compressor/ Condensor Fan: Off
		The switch is defective.	Check if the pressure switch is OK.	If defective, replace.	
		Connection to the corresponding input terminal is disconnected or the controller board is defective.	Check if the connection is OK. Check if the controller board is OK.	Repair connection. If the controller board is defective, replace.	
High Pressure Alarm	Alarm is activated when a high pressure event is present in the refrigeration system.	Abnormal site condition	Check open door or for abnormal site condition. Check if the high pressure value is in the normal range.	Clean the condenser.	Compressor/ Condensor Fan: Off
		Condenser fan has failed. The condenser fan speed controller has failed.	Check the condenser fan status while the high pressure is outside the normal setting.	Replace the condenser fan. Replace the condenser low ambient (fan speed) controller.	
		The switch is defective.	Check if the high pressure switch is OK.	If defective, replace.	
		Connection to the corresponding input terminal is disconnected or the controller board is defective.	Check if the connection is OK. Check if the controller board is OK.	Repair connection. If the controller board is defective, replace.	
Dirty Air Filter Alarm	The alarm is a warning to check the filter. Alarm can only be reset manually.	Filter is clogged.	Check if the filter is dirty.	Clean or replace the filter.	
		Connection to the corresponding input terminal is disconnected or the controller board is defective.	Check if the connection is OK. Check if the controller board is OK.	Repair connection. If the controller board is defective, replace.	
		The value set for the differential air pressure switch is too low.	Check the differential air pressure switch value.	Correct the value of the switch to standard value.	
Freeze Alarm	Low temperature detected at evaporator coil.	Low airflow	Blower	Ensure blower is operating correctly.	Compressor: Off Blower: On
		Low load	Space temperature input	Ensure sensor is operating correctly.	

TROUBLESHOOTING MULTI-TEC WALL-MOUNT UNIT ALARMS (CONT.)



Signal	Description	Possible Cause	Component to Check	Recommended Action	Device Actions
Mixed Air Temperature Sensor Failed Alarm	The alarm is activated if the sensor is faulty, a sensor wire is loose or an out-of-range value is read.	The alarm is activated if the sensor is faulty, a sensor wire is loose or an out-of-range value is read.	Check the mixed air temperature sensor wiring. Check temperature vs. resistance of temperature sensor.	Replace the supply air temperature sensor.	
Outdoor Temperature Sensor Failed Alarm	The alarm is activated if the sensor is faulty, a sensor wire is loose or an out-of-range value is read.	The alarm is activated if the sensor is faulty, a sensor wire is loose or an out-of-range value is read.	Check the outdoor temperature sensor wiring. Check temperature vs. resistance of temperature sensor.	Replace the outdoor temperature sensor.	
Outdoor Humidity Sensor Failed Alarm	The alarm is activated if the sensor is faulty, a sensor wire is loose or an out-of-range value is read.	The alarm is activated if the sensor is faulty, a sensor wire is loose or an out-of-range value is read.	Check the humidity sensor wiring.	Replace the humidity sensor.	
Return Air Temperature Sensor Failed Alarm	The alarm is activated if the sensor is faulty, a sensor wire is loose or an out-of-range value is read.	The alarm is activated if the sensor is faulty, a sensor wire is loose or an out-of-range value is read.	Check the return air temperature sensor wiring. Check temperature vs. resistance of temperature sensor.	Replace the return air temperature sensor.	
High Mixed Air Temperature Alarm	During economizer operation, MAT was above alarm setpoint.	Bringing in warm air from outside.	Damper	Verify damper operation.	
			OAT sensor	Verify sensor operation.	
Low Mixed Air Temperature Alarm	During economizer operation, MAT was below alarm setpoint.	Bringing in cool air from outside.	Damper	Verify damper operation.	
			OAT sensor	Verify sensor operation.	
Damper Open Fail Alarm	Alarm is reset automatically.	Free cooling damper fails to open.	Check the damper linkage. Check to see if anything is in the way of the damper.		Indoor Blower: On Damper: Off
Damper Close Fail Alarm	Alarm is reset automatically.	Free cooling damper fails to close.	Check the damper linkage. Check to see if anything is in the way of the damper.		Indoor Blower: On Damper: Off
Smoke Alarm	Smoke detector input signals smoke event.	Smoke sensor fail.	Smoke detector	Replace smoke detector	Unit disabled

SECTION 3:

APPENDIX

WALL-MOUNT UNIT ARCHITECTURE

CAUTION: This Bard Free Cooling Unit System has been pre-programmed with what is widely considered to be the best settings for efficiency and operation. Any changes to internal programming through the LC6000 controller or the TEC-EYE™ not covered within this manual may cause the systems to operate improperly, cause internal damage to the HVAC units, cause the shelter to overheat or other very serious consequences. Although complete controller programming architecture for the wall-mount unit controller has been provided, going outside the boundaries of what has been covered in this manual is not recommended.

Screen	Menu Item	Range	Default Value	Description
STATUS SCREEN				
	RAT	-999.9 to 999.9	-	Return air temperature
	MAT	-999.9 to 999.9	-	Mixed air temperature
	OAT	-999.9 to 999.9	-	Outdoor air temperature (if equipped with economizer)
	OAH	-999.9 to 999.9	-	Outdoor air humidity (if equipped with economizer)
	ODP	-999.9 to 999.9	-	Outdoor dew point (if equipped with economizer)
	Blower	ON/OFF	-	Blower status
	Damper	0-100%	-	Damper position (if equipped with economizer)
	Unit Status	Active, Waiting, Unit On, Off by Alarm, Off by pLan, Off by BMS, Off by Clock, Off by Input, Off by Keypad, Off by Manual, Off by LC	-	Unit status
Press UP or DOWN Arrow Key to Icon, then ENTER Key				
QUICK MENU				
	Data Log 			Heading
	Data Logger Record			
	Record Number	0-99	-	Record number (located in upper right hand corner)
	Time	00:00 - 23:59	-	Time of the alarm event
	Date	00/00/00 - 12/31/99	-	Date of the alarm event
	Description	Text	-	Description of the alarm event
	Event	Start/Stop	-	Describes if entry is beginning or end of event
NOTE: Data Log will have as many screens as events occurred using same format.				
Press BACK Key				
Press DOWN Key				
Press ENTER Key				
	Info 			
	Last Hour Tracking			
	Freecool Run	0-59	-	Number of minutes in last hour

Screen	Menu Item	Range	Default Value	Description
	Freecool ST	0-59	-	Number of starts in last hour
	Cooling 1 Run	0-59	-	Number of minutes in last hour
	Cooling 1 ST	0-59	-	Number of starts in last hour
	Cooling 2 Run	0-59	-	Number of minutes in last hour
	Cooling 2 ST	0-59	-	Number of starts in last hour
	Heat 1 Run	0-59	-	Number of minutes in last hour
	Heat 1 ST	0-59	-	Number of starts in last hour
	Heat 2 Run	0-59	-	Number of minutes in last hour
	Heat 2 ST	0-59	-	Number of starts in last hour
Press DOWN Key				
	Unit On Run	0-59	-	Number of minutes in last hour
	Unit On St	0-59	-	Number of starts in last hour
Press DOWN Key				
	Blower Run	0-59	-	Number of minutes in last hour
	Blower St	0-59	-	Number of starts in last hour
Press DOWN Key				
	Multi-Tec Wall Unit			Descriptive Text
	Code	-	MTS1000	Software code
	SW Ver.		-	Software version number
	OS Ver.		-	Operating system version number
	BOOT Ver.		-	Boot version number
Press DOWN Key				
	System Info			
	Board Type	-	-	-
	Board Size	-	Small	Board size
	Board Temp			
	Ret Mem Writes			
	Main Task			
Press DOWN Key				
	Work Hours			
	Unit			
Press DOWN Key				
	Blackout Info			
	Current Time	HH/MM/SS	-	Displays current time
	Power Off Time	HH/MM/SS	-	Displays power off time
	Length Last Time Off	Days, Hours, Min		Displays length of last time off
Press BACK Key				
Press DOWN Key				
Press ENTER Key				
	Set (Setpoints) 			
	Local Cool	65-90°F	77°F	Local cooling setpoint
	Local Heat	52-75°F	60°F	Local heating setpoint
	Current Cool	65-90°F	77°F	Current cooling setpoint

WALL-MOUNT UNIT ARCHITECTURE (CONT.)

Screen	Menu Item	Range	Default Value	Description
	Current Heat	52-75°F	60°F	Current heating setpoint
Press MENU Key two (2) times				
	Insert Password	0000-9999		Password entry for settings access
MAIN MENU				
A	SYS CONFIG			Menu item
A1	Unit Setup			Heading
	Controller Address	1-14	1	Address of wall unit used to communicate with LC
	UOM	USA, SI, NC,LON, CAN, UK	USA	Used to set the units of variables
	Unit Zone	0, 1, 2, 3	1	Select the zone in which the unit will operate
	Mode			
	Fan Management Continuously Running Blower	None, Lead, Both	None	Used to determine continuous fan operation
Press DOWN Key				
A2	Cooling Setup			
	Cooling Compressors	1, 2	1	Determines the number of mechanical cooling stages
	Temperature Regulation			Descriptive text
	Stage 1 Diff On	-999.9 to 999.9	2.0°F	Differential on for stage 1
	Stage 1 Diff Off	-999.9 to 999.9	-4.0°F	Differential off for stage 1
	Stage 2 Diff On	-999.9 to 999.9	3.0°F	Differential on for stage 2
	Stage 2 Diff Off	-999.9 to 999.9	-2.2°F	Differential off for stage 2
	Stage 3 Diff On	-999.9 to 999.9	4.0°F	Differential on for stage 3
	Stage 3 Diff Off	-999.9 to 999.9	2.0°F	Differential off for stage 3
Press DOWN Key				
A3	Heating Setup			
	Heating Stages	1, 2, 3	1	Determines the number of heating stages
	Temperature Regulation			Descriptive text
	Stage 1 Diff On	-999.9 to 999.9	1.0°F	Differential on for stage 1
	Stage 1 Diff Off	-999.9 to 999.9	-2.0°F	Differential off for stage 1
	Stage 2 Diff On	-999.9 to 999.9	3.0°F	Differential on for stage 2
	Stage 2 Diff Off	-999.9 to 999.9	-1.0°F	Differential off for stage 2
	Stage 3 Diff On	-999.9 to 999.9	4.0°F	Differential on for stage 3
	Stage 3 Diff Off	-999.9 to 999.9	2.0°F	Differential off for stage 3
Press DOWN Key				
A4	Economizer			
	Type	Dry Bulb, Enthalpy, Temp Hum, None	Enthalpy	Selects the type of economizer operation
	Enthalpy Configuration			Descriptive text
	Outdoor Set	-999.9 to 999.9	65.0°F	Setpoint to limit economizer operation

Screen	Menu Item	Range	Default Value	Description
	On Diff	-999.9 to 999.9	5.0°F	Differential used by outdoor setpoint
	OA Humid Set	0-100%	80%	Setpoint to limit economizer operation
Press DOWN Key				
A5	Economizer			
	OA Dew Pt Set	-999.9 to 999.9	55.0°F	Setpoint used to limit economizer operation
	On Diff	-999.9 to 999.9	5.0°F	Differential used by OA dewpoint setpoint
	Dewpoint Delay	0-32767	120 sec	Time delay used for dewpoint conditions
Press DOWN Key				
A6	Unit Config			
	Damper Modulation			Descriptive text
	Mixed FC Set	-999.9 to 999.9	55.0°F	Setpoint being used by economizer PID
	Gain	-999.9 to 999.9	20.0°F	Proportional gain used by PID
	Integral	0-65535	120 sec	Integral time used by PID
	Derivative	0-65535	0 sec	Derivative time used by PID
Press DOWN Key				
A7	Alarm Config			Heading
	Mixed Air Alarms			Descriptive text
	Diff Lo	-999.9 to 999.9	10	Low differential for alarm
	Diff Hi	-999.9 to 999.9	5.0	High differential for alarm
	Del	0-32767	30 sec	Delay for alarm
	Low Pressure Alarms			Descriptive text
	OAT	-999.9 to 999.9	55.0°F	OAT setpoint for alarm
	Diff	-999.9 to 999.9	5.0	Differential for OAT setpoint
	Del	0-32767	120 sec	Delay used for alarm (OAT above setpoint)
	LDel	0-32767	180 sec	Delay used for alarm (OAT below setpoint)
	Two Count Del	0-32767	900 sec	Delay before retry counter resets
Press DOWN Key				
A8	Alarm Config			
	Damper Alarms			
	Open Del		20 sec	Time delay before alarm occurs on fail to open
	Close Del		300 sec	Time delay before alarm occurs on fail to close
	Freeze Alarm			
	Low Temp		33.0°F	Setpoint for freeze alarm
	Reset Temp		55.0°F	Temperature for auto reset of alarm
	Reset Del		300 sec	Time delay for auto reset of alarm
Press DOWN Key				
A9	Alarm Config			
	Air Flow Alarm			

WALL-MOUNT UNIT ARCHITECTURE (CONT.)

Screen	Menu Item	Range	Default Value	Description
	Del	0-32767	45 sec	Delay for alarm
Press DOWN Key				
A10	Run Test			
	Damper Test Volts	0-10 volts	10	Damper position command for run test
	Damper Time	0-999 sec	150	Time that damper will open for and close for
	Heat/Cool Time	0-999 sec	60	Time that unit will cool for and heat for
	Run Test Enable	On/Off	Off	Set to on to begin run test
End of SYS CONFIG				
Press BACK Key				
Press DOWN Key				
B	ADV SYS CONFIG			Menu item
B1	Factory Settings			Heading
	Serial Number	15 Digit ASCII	-	Enter Serial Number
	Model Number	15 Digit ASCII	-	Enter Model Number
Press DOWN Key				
B2	Unit Config			Heading
	Compressor Safety Timers			Descriptive text
	Min On	0-32767	180 sec	Minimum on time for compressor
	Min Off	0-32767	120 sec	Minimum off time for compressor
	Min On Same	0-32767	120 sec	Minimum on for unloader
	Unloader Del	0-32767	120 sec	Delay before unloader becomes active
	Address Del	0-32767	5 sec	Time delay based on unit address
Press DOWN Key				
B3	Change Password			
End of ADV SYS CONFIG				
Press BACK Key				
Press DOWN Key				
C	I/O CONFIG			Menu item
C1	Digital In Config			Heading
	Channel 1 Smoke			Descriptive text
	Dir	NO/NC	NO	Changes direction of input
	En	On/Off	Off	Enable/disable input
	Val	On/Off	-	Shows current value of input
	Channel 2 Filter			Descriptive text
	Dir	NO/NC	NO	Changes direction of input
	En	On/Off	On	Enable/disable input
	Val	On/Off	-	Shows current value of input
	Channel 3 High Pressure			Descriptive text
	Dir	NO/NC	NO	Changes direction of input
	En	On/Off	On	Enable/disable input
	Val	On/Off	-	Shows current value of input

Screen	Menu Item	Range	Default Value	Description
	Channel 4 Low Pressure			Descriptive text
	Dir	NO/NC	NO	Changes direction of input
	En	On/Off	On	Enable/disable input
	Val	On/Off	-	Shows current value of input
	Channel 6 Damper			Descriptive text
	Dir	NO/NC	NC	Changes direction of input
	En	On/Off	On	Enable/disable input
	Val	On/Off	-	Shows current value of input
Press DOWN Key				
C2	Mixed Air Sensor			Heading
	Channel 1			Descriptive text
	Raw	-999.9 to 999.9	-0.1	Raw value of input
	Enable	On/Off	On	Used to enable/disable the sensor
	Filter Intensity	0-10	5	Used to increase or decrease the filter for input
	Offset	-999.9 to 999.9	0.0°F	Offset applied to input
	Value	-999.9 to 999.9	303.0°F	Display value of input
Press DOWN Key				
C3	Outdoor Air Sensor			Heading
	Channel 2			Descriptive text
	Raw	-999.9 to 999.9	-0.1	Raw value of input
	Enable	On/Off	On	Used to enable/disable the sensor
	Filter Intensity	0-10	5	Used to increase or decrease the filter for input
	Offset	-999.9 to 999.9	0.0°F	Offset applied to input
	Value	-999.9 to 999.9	303.0°F	Display value of input
Press DOWN Key				
C4	Return Air Sensor			Heading
	Channel 3			Descriptive text
	Raw	-999.9 to 999.9	-0.1	Raw value of input
	Enable	On/Off	On	Used to enable/disable the sensor
	Filter Intensity	0-10	5	Used to increase or decrease the filter for input
	Offset	-999.9 to 999.9	0.0°F	Offset applied to input
	Value	-999.9 to 999.9	303.0°F	Display value of input
Press DOWN Key				
C5	Outdoor Hum Sensor			Heading
	Channel 5			Descriptive text
	Raw	-999.9 to 999.9	-0.1	Raw value of input
	Enable	On/Off	On	Used to enable/disable the sensor
	Filter Intensity	0-10	5	Used to increase or decrease the filter for input
	Offset	0-100%	0%	Offset applied to input
	Value	0-100%	-	Display value of input

WALL-MOUNT UNIT ARCHITECTURE (CONT.)

Screen	Menu Item	Range	Default Value	Description
	Press DOWN Key			
C6	Freeze Sensor			Heading
	Channel 7			Descriptive text
	Raw	-999.9 to 999.9	-0.1	Raw value of input
	Enable	On/Off	On	Used to enable/disable the sensor
	Filter Intensity	0-10	5	Used to increase or decrease the filter for input
	Offset	-999.9 to 999.9	0.0°F	Offset applied to input
	Value	-999.9 to 999.9	303.0°F	Display value of input
End of I/O CONFIG				
	Press BACK Key			
	Press DOWN Key			
D	ON/OFF	On/Off	On	Allows cooling or heating operation
End of ON/OFF				
	Press BACK Key			
	Press DOWN Key			
E	ALARM LOGS			Menu item
	Record Number	0-99	-	Record number (located in upper right corner)
	Time	00:00 to 23:59	-	Time of alarm event
	Date	00/00/00 - 12/31/99	-	Date of alarm event
	Description	Text	-	Description of alarm event
	Event	Start/Stop	-	Describes if entry is beginning or end of event
	NOTE: Alarm log will have as many screens as events occurred using same format.			
End of ALARM LOGS				
	Press BACK Key			
	Press DOWN Key			
F	SETTINGS			Menu item
	Date/Time			
	Date/Time Change			
	Time	00:00 to 23:59		Enter new time
	Format	MM/DD/YY, DD/MM/YY, YY/MM/DD	DD/MM/YY	Sets the display format of the date
	Day	0-31		Enter new day
	Month	0-12		Enter new month
	Year			Enter new year
	Press DOWN Key			
	Timezone			
	Current		Reykjavik	Displays current timezone
	New Timezone			Enter new timezone
	Update Timezone	No/Yes	No	Set to yes to apply new timezone

Screen	Menu Item	Range	Default Value	Description
	Press DOWN Key			
	Language			
	Language	English, Italiano, Deutsch, Francais, Espanol	English	Press ENTER to change or BACK to confirm
	Press MENU Key			
	Press DOWN Key to SETTINGS			
	Press ENTER Key			
	Press DOWN Key to Initialization			
	Initialization			
	Alarm Initialization			
	Delete Alarm Logs?	No/Yes	No	Yes will delete all alarm logs
	Clear Autoreset Counters?	No/Yes	No	Yes will clear automatic reset counters
	Enable Buzzer?	Yes/No	Yes	Sounds buzzer for alarms when enabled
	Press DOWN Key			
	Default Installation			
	Wipe Retain Mem.	No/Yes	No	Yes will apply factory settings
	Wipe NVRAM Mem.	No/Yes	No	Yes will erase saved files
	Wipe Both Mem.	No/Yes	No	Yes wipes both retain and NVRAM
	Press DOWN Key			
	Unit Configuration			
	Param Import/Export			
	Import/Export	Import/Export	Import	Selects the import or export operation
	Memory Type	Internal Flash Memory/USB	Internal Flash Memory	Selects memory location
	File Name			Selects file name to be imported or exported
	Confirm	No/Yes	No	Yes will begin import or export
	Press DOWN Key			
	Alarm Export			
	Memory Type	Internal Flash Memory/USB	Internal Flash Memory	Selects memory location
	File Name			Selects file name to be imported or exported
	Confirm?	No/Yes	No	Yes will begin import or export
	End of SETTINGS			
	Press BACK Key two (2) Times			
	Press DOWN Key			
G	LOG OUT			Used to log out and force password entry