

---

# SERVICE INSTRUCTIONS

---

## MEGA-TEC™ WALL-MOUNT AIR CONDITIONER

Model W120AP



***NOTE: LC6000 controller is required for operation when W120AP units are used.***



Climate Control Solutions

Bard Manufacturing Company, Inc.  
Bryan, Ohio 43506  
[www.bardhvac.com](http://www.bardhvac.com)

Manual: 2100-671  
Supersedes: **NEW**  
Date: 12-17-18

# CONTENTS

---

## General Information .....4

Multi-Stage Cooling System .....	4
Wall-Mount Air Conditioner Units.....	4
General .....	4
Shipping Damage.....	4
Additional Publications.....	4

## Using the TEC-EYE™ .....6

TEC-EYE Hand-Held Diagnostic Tool .....	6
TEC-EYE Menu Structure .....	7
TEC-EYE Acronyms .....	7
Main Status Screen .....	7
Quick Menu .....	8
Setpoints .....	8
Information .....	8
A/C Circuit Information .....	8
Program Version .....	9
Alarm Log .....	9
Menu Screens and Password Levels.....	9
Executing a Run Test .....	10
Run Test Parameter Descriptions .....	10
Reset to Factory Defaults .....	10

## Operation .....11

Unit On/Off .....	11
Alarm Adjustment .....	11
Acknowledging Alarms .....	11
Clearing Alarms .....	11
Clearing Alarm Logs and Counters .....	11
Exporting Alarm Logs .....	11
Exporting 7 Day Logs .....	12
Exporting Parameters .....	12
Zone .....	12
Temperature Control .....	12
Temperature Control Components.....	12
Return Air Temperature Sensor.....	12
Return Air Temperature Alarm.....	12
Temperature Control Operation.....	12
Orphan Mode.....	13
LC6000 Control.....	13
Cooling (with Economizer).....	13
Cooling (without Economizer) .....	13
Heating.....	13
Electronic Expansion Valve (EEV).....	14
EEV Components.....	14
Electronic Expansion Valve.....	14
EEV Instructions for Vacuum, Reclaim, Charge Unit.....	14
System Pressures .....	15
Suction Pressure Transducer .....	15
Troubleshooting the Suction Pressure Transducer.....	15
Suction Pressure Alarm.....	16
Suction Temperature Sensor.....	16
Suction Temperature Alarm .....	16
Evaporator Freeze Condition Alarm .....	16
EEV Operation.....	17
EEV Superheat Control .....	17
Additional EEV Alarms .....	17
Low Superheat Alarm .....	17

Indoor Airflow .....	17
Indoor Airflow Components .....	17
Blower .....	17
Blower Status Switch .....	18
Blower Status Alarm .....	18
Filters.....	18
Dirty Filter Switch .....	18
Dirty Filter Alarm.....	18
Filter Indicator Light .....	19
Indoor Airflow Operation.....	19
Blower Speed Control .....	19
Additional Indoor Airflow Alarms .....	19
Supply Air Temperature Alarm .....	19
Condenser Fan.....	19
Condenser Fan Components.....	19
Condenser Fan.....	19
Liquid Pressure Sensor.....	20
Troubleshooting the Discharge/ Liquid Pressure Transducer .....	20
Discharge/Liquid Pressure Transducer Alarm .....	21
Liquid Temperature Sensor .....	21
Outdoor Temperature Sensor .....	21
Condenser Fan Operation .....	21
Condenser Fan Speed Control.....	21
Compressor .....	21
Compressor Components .....	21
Compressor .....	21
Compressor Control Module (CCM).....	22
Delay-on-Make Timer .....	22
Short Cycle Protection/ Delay-on-Break.....	22
High Pressure Detection.....	22
Test Mode.....	23
Brownout Protection w/Adjustment .....	23
High Pressure Safety Switch .....	23
Refrigerant High Pressure Alarm .....	23
Phase Monitor .....	23
Compressor Operation .....	23
Additional Compressor Alarms .....	24
Refrigerant Low Pressure Alarm .....	24
Economizer .....	24
Economizer Components .....	24
Actuator.....	24
Dust Sensor.....	25
Dust Sensor Failure Alarm.....	25
High Dust Limit Alarm .....	25
Damper Blade.....	26
Damper Switch .....	26
Damper Failed to Open Alarm .....	26
Damper Failed to Close Alarm.....	26
Outdoor Temperature and Humidity Combination Sensor .....	26
Outdoor Temperature Sensor Failure Alarm .....	27
Outdoor Humidity Sensor Failure Alarm .....	27

Mixed Air Temperature Sensor.....27	Figure 19	Voltage to Pressure: Suction Pressure Transducer.....16
High Mixed Air Temperature Alarm.....27	Figure 20	Adjusting Suction Temperature Sensor Values.....16
Low Mixed Air Temperature Alarm.....28	Figure 21	Adjusting Evaporator Freeze Sensor Values.....17
Economizer Operation.....28	Figure 22	Putting Blower Output into Override Mode.....17
Economizer Operation – Minimum Position.....29	Figure 23	Dirty Filter Switch and Blower Status Switch.....18
Miscellaneous Components.....30	Figure 24	Verifying Differential Airflow Status.....18
Supply Temperature Sensor.....30	Figure 25	Dirty Filter Switch and Filter Indicator Light.....19
Supply Temperature Sensor Failure Alarm.....30	Figure 26	Enabling Fan Override.....20
Emergency Cooling Mode.....30	Figure 27	Adjusting Discharge/Liquid Transducer Pressure Values.....20
Emergency Cooling – Orphan Mode.....30	Figure 28	Voltage to Pressure: Discharge/Liquid Pressure Transducer.....20
Emergency Ventilation Mode.....31	Figure 29	Adjusting Discharge/Liquid Temperature Input.....21
Electric Heat Option.....31	Figure 30	8201-164 Compressor Control Module.....22
Electric Heat Components.....31	Figure 31	Adjusting Compressor Delays.....24
Electric Heating Element.....31	Figure 32	Damper Override.....24
Thermal Overload.....31	Figure 33	Dust Sensor.....25
Electric Heat Operation.....31	Figure 34	Adjusting Dust Sensor Alarm Setpoint.....25
Unit Disable Option.....31	Figure 35	Damper Blade Position.....26
Serial/Model Number Configuration.....31	Figure 36	Damper Switch.....26
<b>Refrigerant Information.....34</b>	Figure 37	Outdoor Temperature Sensor.....27
General.....34	Figure 38	Outdoor Humidity Sensor.....27
Topping Off System Charge.....34	Figure 39	Mixed Air Temperature Sensor.....27
Safety Practices.....34	Figure 40	Economizer Setup.....29
Important Installer Note.....34	Figure 41	Economizer Setup – Dry Bulb Control.....29
R410-A Refrigerant Charge.....34	Figure 42	Economizer Setup – TempHum Control.....29
Pressure Service Ports.....35	Figure 43	Economizer Setup – Enthalpy Control.....29
<b>Maintenance.....36</b>	Figure 44	Supply Air Temperature Sensor.....30
Standard Maintenance Procedures.....36	Figure 45	Emergency Cool – Orphan Mode.....30
<b>Troubleshooting.....37</b>	Figure 46	Adjusting Return Air Alarm Settings.....31
8301-089 Outdoor Temperature Temperature/Humidity Sensor.....37	Figure 47	Unit Disable Option.....31
8620-296 Supply Air Sensor/Return Air Sensor/Mixed Air Sensor/Suction Sensor/Liquid Sensor.....40	Figure 48	Serial/Model Number Configuration.....32
8301-057 Blower Status Switch/Dirty Filter Switch.....41	Figure 49	MEGA-TEC Wall-Mount Unit Model Nomenclature.....33
Alarm Index.....42	Figure 50	8301-089 Sensor DIP Switches and Terminal Block.....37
Blower Speeds.....44	Figure 51	8301-057 Air Differential Switch Terminals.....41
<b>FIGURES AND TABLES</b>	Table 1	Unit Status Message.....7
Figure 1	Table 2	LC6000/TEC-EYE Passwords (Defaults).....9
Figure 2	Table 3	Rated Airflow.....17
Figure 3	Table 4	Indoor Blower Performance.....17
Figure 4	Table 5	Maximum ESP of Operation: Electric Heat Only.....18
Figure 5	Table 6	Economizer Default Settings.....29
Figure 6	Table 7	Cooling Pressures.....35
Figure 7	Table 8	8301-089 Sensor: Temperature/Resistance.....38
Figure 8	Table 9	8301-089 Sensor: Humidity/mA.....39
Figure 9	Table 10	8620-296 Sensor: Temperature/Resistance Curve J.....40
Figure 10	Table 11	MEGA-TEC Alarm Index.....42
Figure 11	Table 12	Blower Speeds.....44
Figure 12		
Figure 13		
Figure 14		
Figure 15		
Figure 16		
Figure 17		
Figure 18		

# GENERAL INFORMATION

---

## Multi-Stage Cooling System

This Bard cooling system is composed of MEGA-TEC Series wall-mounted air conditioners matched with an LC6000 lead/lag controller. The wall mounts are specifically engineered for telecom/motor control center rooms.

**NOTE:** *The LC6000 lead/lag controller and MEGA-TEC Series wall-mount units are designed specifically to work together. The controller cannot run other brands of systems, nor can other controllers run the MEGA-TEC Series wall-mount units. They are a complete system, and must be used together.*

## Wall-Mount Air Conditioner Units

The wall-mount units operate on VAC power. The units will supply 100% of rated cooling airflow in free cooling mode with ability to exhaust the same amount through the unit itself without any additional relief openings in the shelter.

Each of these units are fully charged with refrigerant and have optional auxiliary heat.

## General

The equipment covered in this manual is to be installed by trained, experienced service and installation technicians.

The refrigerant system is completely assembled and charged. All internal wiring is complete.

The unit is designed for use without duct work. Flanges are provided for transition from unit to wall grilles.

These instructions explain the recommended method to install the air cooled self-contained unit and the electrical wiring connections to the unit.

These instructions and any instructions packaged with any separate equipment required to make up the entire air conditioning system should be carefully read before beginning the installation. Note particularly any tags and/or labels attached to the equipment.

While these instructions are intended as a general recommended guide, they do not supersede any national and/or local codes in any way. Authorities having jurisdiction should be consulted before the installation is made. See **Additional Publications** for information on codes and standards.

Sizing of systems for proposed installation should be based on heat loss and heat gain calculations made according to methods of Air Conditioning Contractors of America (ACCA). The supply flange should be installed in accordance with the *Standards of the National Fire Protection Association for the Installation of Air*

*Conditioning and Ventilating Systems of Other Than Residence Type, NFPA No. 90A, and Residence Type Warm Air Heating and Air Conditioning Systems, NFPA No. 90B.* Where local regulations are at a variance with instructions, installer should adhere to local codes.

## Shipping Damage

Upon receipt of equipment, the cartons should be checked for external signs of shipping damage. If damage is found, the receiving party must contact the last carrier immediately, preferably in writing, requesting inspection by the carrier's agent.

**These units must remain in upright position at all times; do not lay on side. Do not stack units.**

## Additional Publications

These publications can help when installing the air conditioner. They can usually be found at the local library or purchased directly from the publisher. Be sure to consult the current edition of each standard.

National Electrical Code .....ANSI/NFPA 70  
Standard for the Installation of Air Conditioning  
and Ventilating Systems .....ANSI/NFPA 90A  
Standard for Warm Air Heating  
and Air Conditioning Systems .....ANSI/NFPA 90B  
Load Calculation for Residential Winter  
and Summer Air Conditioning ..... ACCA Manual J

For more information, contact these publishers:

**Air Conditioning Contractors of America (ACCA)**  
1712 New Hampshire Ave. N.W.  
Washington, DC 20009  
Telephone: (202) 483-9370 Fax: (202) 234-4721

**American National Standards Institute (ANSI)**  
11 West Street, 13th Floor  
New York, NY 10036  
Telephone: (212) 642-4900 Fax: (212) 302-1286

**American Society of Heating, Refrigeration and Air  
Conditioning Engineers, Inc. (ASHRAE)**  
1791 Tullie Circle, N.E.  
Atlanta, GA 30329-2305  
Telephone: (404) 636-8400 Fax: (404) 321-5478

**National Fire Protection Association (NFPA)**  
Batterymarch Park  
P. O. Box 9101  
Quincy, MA 02269-9901  
Telephone: (800) 344-3555 Fax: (617) 984-7057

### **ANSI Z535.5 Definitions:**

**DANGER:** Indicate[s] a hazardous situation which, if not avoided, will result in death or serious injury. The signal word “DANGER” is to be limited to the most extreme situations. DANGER [signs] should not be used for property damage hazards unless personal injury risk appropriate to these levels is also involved.

**WARNING:** Indicate[s] a hazardous situation which, if not avoided, could result in death or serious injury. WARNING [signs] should not be used for property damage hazards unless personal injury risk appropriate to this level is also involved.

**CAUTION:** Indicate[s] a hazardous situation which, if not avoided, could result in minor or moderate injury. CAUTION [signs] without a safety alert symbol may be used to alert against unsafe practices that can result in property damage only.

**NOTICE:** [this header is] preferred to address practices not related to personal injury. The safety alert symbol shall not be used with this signal word. As an alternative to “NOTICE” the word “CAUTION” without the safety alert symbol may be used to indicate a message not related to personal injury.



## **WARNING**

***Electrical shock hazard.***

***Have a properly trained individual perform these tasks.***

***Failure to do so could result in electric shock or death.***

## **WARNING**

***Fire hazard.***

***Maintain minimum 1/4" clearance between the supply flange and combustible materials.***

***Failure to do so could result in fire causing damage, injury or death.***

## **WARNING**

***Heavy item hazard.***

***Use more than one person to handle unit.***

***Failure to do so could result in unit damage or serious injury.***

## **CAUTION**

***Cut hazard.***

***Wear gloves to avoid contact with sharp edges.***

***Failure to do so could result in personal injury.***

# USING THE TEC-EYE™

**FIGURE 1**  
TEC-EYE (Bard P/N 8301-059) Display and Interface (Status Screen Shown)

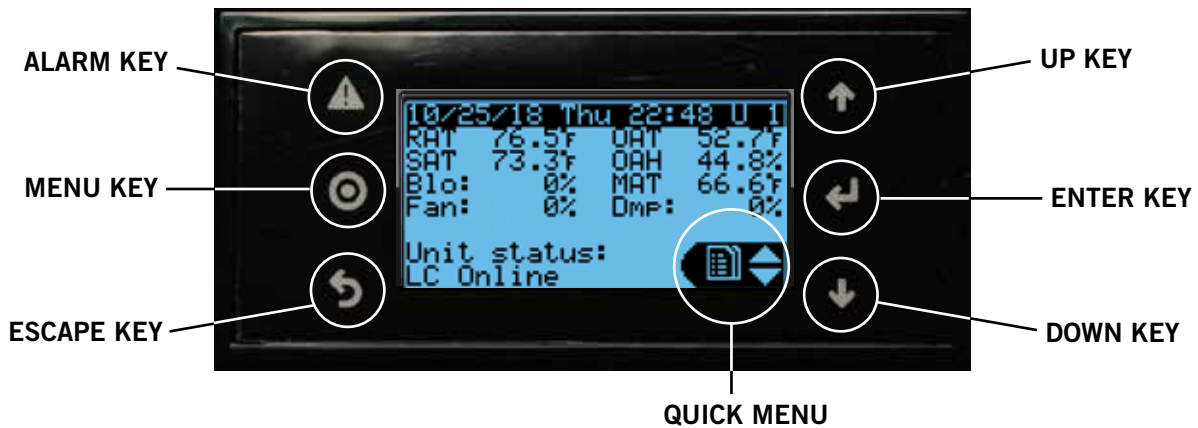

- ALARM KEY**  
Allows viewing of active alarms  
Silences audible alarms  
Resets active alarms
- MENU KEY**  
Allows entry to Main Menu
- ESCAPE KEY**  
Returns to previous menu level  
Cancels a changed entry

- UP KEY**  
Steps to next screen in the display menu  
Changes (increases) the value of a modifiable field
- ENTER KEY**  
Accepts current value of a modifiable field  
Advances cursor
- DOWN KEY**  
Steps back to previous screen in the display menu  
Changes (decreases) the value of a modifiable field

## TEC-EYE Hand-Held Service Tool

The TEC-EYE service tool is used to communicate with the MEGA-TEC unit logic board. By connecting directly to the logic board inside the unit control panel, it is possible to perform diagnostics on the unit, adjust certain settings and verify unit and economizer operation through a run test procedure. **The TEC-EYE service tool is required for unit setup and operation.** The TEC-EYE is supplied with the LC6000 controller but can also be ordered separately (Bard P/N 8301-059).

The menu driven interface provides users the ability to scroll through two menu levels: Quick Menu and Main Menu. The menus permit the user to easily view, control and configure the unit. See Figure 1 for TEC-EYE display and key functions.

The controller is completely programmed at the factory; the default setpoints and their ranges are easily viewed and adjusted from the TEC-EYE display. The program and operating parameters are permanently stored on FLASH-MEMORY in case of power failure.

The TEC-EYE connects to the wall-mount unit control board via an RJ11 modular phone connector as shown in Figure 2.

**FIGURE 2**  
TEC-EYE Connection to Unit Control

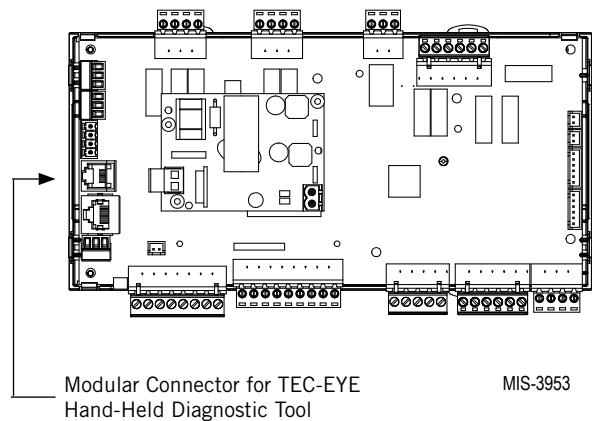

When not being used, the TEC-EYE hand-held diagnostic tool should be stored inside or near the LC6000 controller. Do not let the TEC-EYE leave the shelter.

**NOTE:** Screenshots shown in this manual reflect default settings (when applicable).

## TEC-EYE Menu Structure

- Quick Menu
  - Setpoints
  - Information
  - Alarm Log
- Main Menu
  - System Configuration
  - Advanced System Configuration
  - I/O Configuration
    - Digital Inputs
    - Digital Outputs
    - Analog Inputs
    - Analog Outputs
    - Fans/Blowers
    - Manual EEV
  - On/Off
  - Alarm Logs
  - Settings
    - Date/Time
    - Language
    - Initialization
    - Serial Ports
    - Change Password
  - Logout

In addition to the menu structure above, there are also Status and Alarm screens.

### TEC-EYE Acronyms

MAT – Mixed air temperature  
 RAT – Return air temperature  
 SAT – Supply air temperature  
 OAT – Outdoor air temperature  
 OAH – Outdoor air humidity  
 Blower – Indoor blower speed  
 Fan – Outdoor fan speed  
 Econ – Free cooling

**NOTE:** *Digital refers to On/Off whereas analog is a variable input.*

### Main Status Screen

The main Status screen is the default start-up screen and also the return screen after 5 minutes of no activity. The screen can be accessed at any time by pressing the ESCAPE key repeatedly.

The wall-mount unit address is displayed in the upper right corner on the main Status screen (see Figure 1). The main Status screen also shows the current date, time, mixed air temperature (MAT), return air temperature (RAT), supply air temperature (SAT), outdoor air temperature (OAT) and outdoor air humidity (OAH). Blower speed, condenser fan speed, damper position and unit status are also displayed. See Table 1 for wall-mount unit status messages.

The Quick Menu is accessible from the main Status screen. Setpoints, Information and Alarm Log are available through the Quick Menu. Pressing the UP or

**TABLE 1**  
**Unit Status Messages**

Message	Description
Waiting...	PLC is on and has not started running the application yet.
Orphan Mode	Unit is on and in orphan mode with no calls for heating or cooling.
LC Online	Unit is on and communicating with the LC6000 with no heating or cooling calls.
Cont. Blower	Unit is operating with continuous blower when no heating or cooling calls are present.
Freecooling	Unit is actively economizing.
Optimized Cool	Unit is mechanical cooling while actively economizing.
Cooling	Unit is actively mechanical cooling.
Heating	Unit is actively heating.
Passive Dehum	Unit is taking measures to decrease humidity without using extra energy.
Self Test	Unit is performing a run test.
Off by Alarm	Unit has major fault preventing operation.
Off by LC	Unit has been turned off by the supervisory controller.
Off by Keyboard	Unit has been turned off by the local user.
Emergency Vent	Unit is in Emergency Ventilation. LC6000 has an active hydrogen alarm.
Emergency Cool	Unit is in Emergency Cooling. Indoor temperatures have exceeded high temp alarms.
Emergency Off	Unit is in Emergency Off. LC6000 has an active smoke alarm.

DOWN keys while on the main Status screen will change the Quick Menu icon displayed (see Figure 3). Press the ENTER key when the desired icon is displayed.

**FIGURE 3**  
**Quick Menu Icons**

Data Log

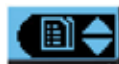

Information



Setpoints



## Quick Menu

### Setpoints

From this screen, the local unit heating and cooling setpoints, used for orphan mode only, can be changed.

Once the supervisory controller is connected, cooling and heating setpoints will be communicated and local cooling and heating setpoints will be replaced with the communicated cooling and heating setpoints.

If at any time the wall-mount unit(s) loses communication with the LC6000 controller, the wall-mount unit(s) will go into orphan mode and operate using the last communicated setpoints.

To verify or change the wall-mount unit cooling and heating setpoints in orphan mode:

1. Connect the TEC-EYE diagnostic tool to the control board located in the unit.
2. From the Status screen, press UP or DOWN key until Quick Menu displays Setpoints icon. Press ENTER key.
3. Press ENTER key to scroll to the selected choice (see Figure 4).
4. Press UP or DOWN key on desired value until value displays correctly.
5. Press ENTER key to save and scroll to next parameter.
6. Press ESCAPE key until Main Menu screen is displayed.

**FIGURE 4**  
Cool and Heat Setpoints

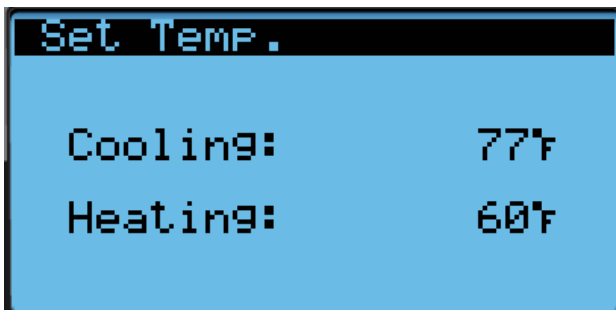

### Information

The information screens are used as a quick reference to show unit A/C circuit measurements and program version.

#### A/C Circuit Information

MEGA-TEC Series wall-mounted air conditioners have two separate refrigeration circuits: Circuit 1 is the two stage system located on the left side of the unit and circuit 2 is the single stage system on the right side.

A/C Circuit Information can be found in four screens within the information menu (see Figure 5). The information and measurements provided are liquid line

temperature, liquid line pressure, condensing saturated temperature, suction line temperature, suction line pressures, suction saturated temperature, super heat, sub-cooling and electronic expansion valve position.

**FIGURE 5**  
A/C Circuit Measurements

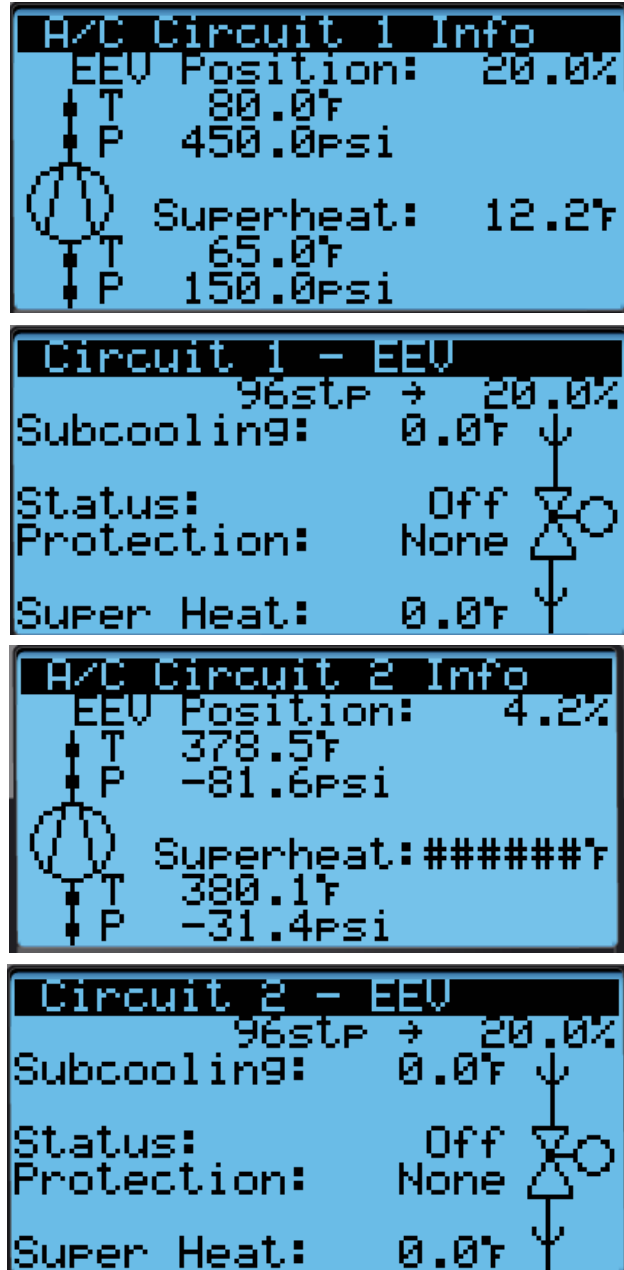



### Program Version

The Program Version screen displays the model number of the unit as well as all program version information for the PLC (see Figure 6). This information can be used to determine whether a software update may be required based on information found in the software change log. This change log can be found at <http://www.bardhvac.com/software-download/>.

**FIGURE 6**  
**Program Version**



# NOTICE

*It is important to check the software version during installation to ensure that the latest version has been installed. Current software versions, change log and installation instructions are available on the Bard website at <http://www.bardhvac.com/software-download/>*

### Alarm Log

The alarm log screens show a log of each alarm. There will be a log for when alarm occurred and if the alarm auto clears, it will show when the alarm cleared. See page 11 for information on clearing alarms.

### Menu Screens and Password Levels

- A** System Config: A1-A5 User (2000)
- B** Adv Sys Config: B1-B4 Technician (1313)
- C** I-O Config: Technician (1313)
- D** On/Off: User (2000)
- E** Alarm Logs: User (1313)
- F** Settings
  - Date/Time: Technician (1313)
  - Language: User (2000)
  - Serial Ports: Technician (1313)
  - Password Change
  - Initialization
    - Alarm Initialization: User (2000)
    - Default Installation: Engineer (9254)
    - Parameters Import/Export: Engineer (9254)
    - Alarm Export: User (2000)
  - Unit of Measure:
- G** Logout: Used to log out of the current password level. Entering back into the menu requires password.

**TABLE 2**  
**LC6000/TEC-EYE Passwords (Defaults)**

User	2000
Technician	1313
Engineer	9254
Use UP or DOWN keys and ENTER key to enter password	

The passwords listed above are the default passwords. End users can change these passwords if additional security is desired.

### Executing a Run Test

This unit has the ability to perform a run test that will operate all available unit functions in order to quickly determine unit operation. Some unit parameters are adjustable.

To execute a run test:

1. Press MENU key to access the Main Menu screen.
2. Press UP or DOWN keys and ENTER key to enter TECHNICIAN password 1313.
3. Press UP or DOWN keys to scroll to **Sys Config**; press ENTER key.
4. Press UP or DOWN keys to scroll to **Run Test A9** screen.
5. Press ENTER key to scroll to **Enable** parameter (see Figure 7).
6. Press UP or DOWN key to change value to **Yes**.
7. Press ENTER key to save value.

**FIGURE 7**  
Executing Run Test

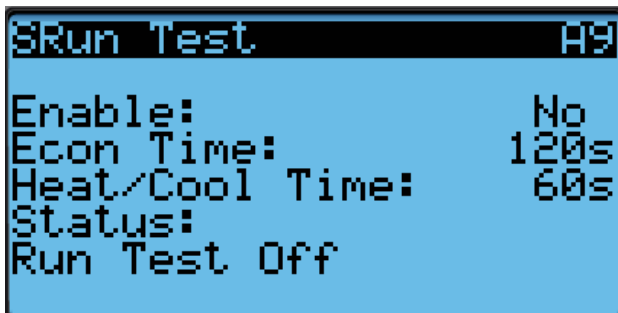

#### **Run Test Parameter Descriptions**

Econ Stage Time: Amount of time (in seconds) allowed for damper blade movement in each direction.

Heat/Cool Stage Time: Amount of time (in seconds) allowed for each stage of heating or cooling.

### Reset to Factory Defaults

To reset to factory default settings:

1. Press MENU key to go to the Main Menu screen.
2. Use UP or DOWN keys and ENTER key to enter ENGINEER password 9254.
3. Press UP or DOWN keys to scroll to **Settings**; press ENTER key.
4. Press UP or DOWN keys to scroll to **Initialization**; press ENTER key.
5. Press UP or DOWN keys to scroll to the **Default Installation** screen.
6. Press ENTER key to scroll to **Wipe retain mem.** (see Figure 8).
7. Press UP or DOWN key to change value to **YES**; press ENTER key.
8. System will restart with default values.

**FIGURE 8**  
Restoring Factory Default Settings

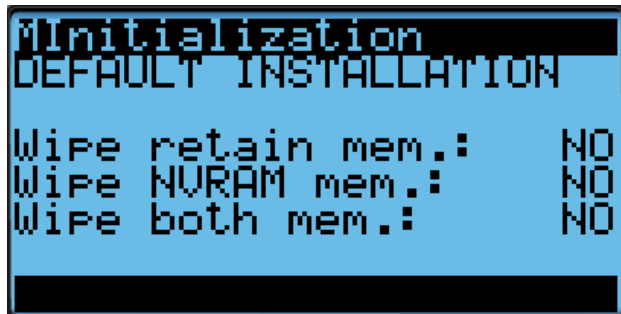

**NOTE:** Screenshots shown in this manual reflect default settings (when applicable).

## Unit On/Off

The wall-mount unit can be turned on and off from the TEC-EYE. Turning the unit off with the following instructions will disable all unit operation.

To turn the unit on or off:

1. Press MENU key to go to the Main Menu screen.
2. Press UP or DOWN keys and ENTER key to enter USER password 2000.
3. Press UP or DOWN keys to scroll to **On/Off**; press ENTER key.
4. Press UP or DOWN keys to change value from On to Off or from Off to On.
5. Press ESCAPE key several times to return to Main Menu screen.

The wall-mount unit may also be turned off by certain events such as the unit disable input, blower offline, fan offline, panel switch open or the return air temperature sensor failure when not connected to the LC6000.

The unit will also be turned off if the unit loses communication with the expansion board, blower motor, condenser fan motor or panel switch for blower or condenser fan compartment.

## Alarm Adjustment

### Acknowledging Alarms

Alarm conditions activate a red LED indicator that backlights the ALARM function key. As an option, an alarm condition may also be enunciated by an audible alarm signal. An alarm is acknowledged by pressing the ALARM key. This calls up alarm display screen(s) that provide a text message detailing the alarm condition(s).

### Clearing Alarms

Alarms can only be cleared after the alarm condition has been corrected. To clear a single alarm, press and hold the ALARM key for 3 seconds while viewing a specific alarm screen. To clear all alarms, navigate to the screen at the end of the alarm list (shown in Figure 9) and press and hold the ALARM key for 3 seconds.

**FIGURE 9**  
Clearing All Alarms



### Clearing Alarm Logs and Counters

To clear the alarm log and alarm counters:

1. Press MENU key to go to the Main Menu screen.
2. Use UP or DOWN keys and ENTER key to enter USER password 2000.
3. Press UP or DOWN keys to scroll to **Settings**; press ENTER key.
4. Press UP or DOWN keys to scroll to **Initialization**; press ENTER key. (**Alarm Management** screen will be displayed.)
5. Press ENTER key to scroll to **Delete alarm logs?** (see Figure 10).
6. Press UP or DOWN key to change value to **YES**; press ENTER key.
7. Press ENTER key to scroll to **Clear AutoReset counters?**
8. Press UP or DOWN key to value to **YES**; press ENTER key.

**FIGURE 10**  
Clearing Alarm Logs and Counters

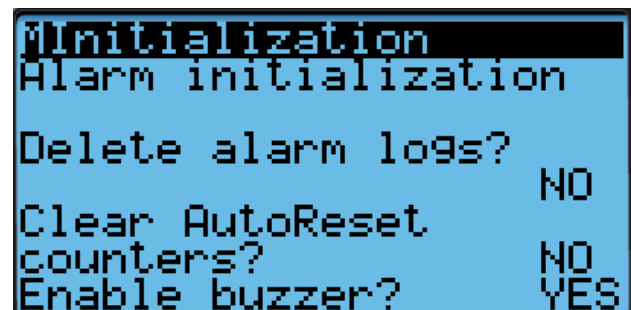

### Exporting Alarm Logs

See latest version of Supplemental Instructions manual 7960-825 for information on exporting alarm logs.

## Exporting 7 Day Logs

See latest version of Supplemental Instructions manual 7960-826 for information on exporting 7 day I/O logs.

## Exporting Parameters

See latest version of Supplemental Instructions manual 7960-827 for information on exporting parameters.

## Zone

When paired with a supervisory controller that uses zones to control groups of wall units, this unit uses the zone setting to relay to the supervisory controller what zone it is set to operate in. Up to three zones can be established with up to 14 units in a single zone. (The LC6000 supervisory controller can control up to a total of 14 units.)

To change the zone:

1. Press MENU key to access the Main Menu screen.
2. Press UP or DOWN keys and ENTER key to enter TECHNICIAN password 1313.
3. Press UP or DOWN keys to scroll to **Sys Config**; press ENTER key.
4. Press UP or DOWN keys to scroll to **Unit Setup A1** screen.
5. Press ENTER key to scroll to **Zone** (see Figure 11).
6. Press UP or DOWN keys to change to the desired value (1, 2 or 3).
7. Press ENTER key to save value.

**FIGURE 11**  
Changing Zone

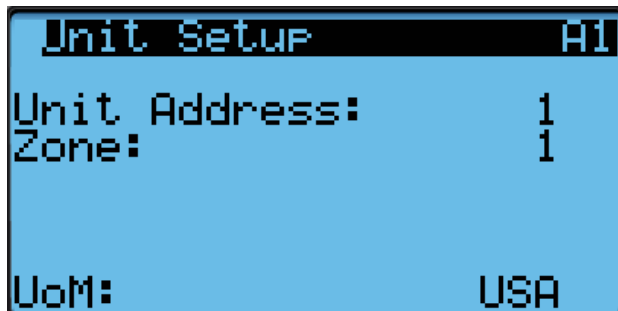

## Temperature Control

### Temperature Control Components

#### Return Air Temperature Sensor

The unit is equipped with a return air temperature sensor to monitor the space temperature when the unit is in orphan mode. The return air sensor is located in the upper part of the return opening in such a way that it is exposed to the entering airstream. An alarm signal will be sent to the LC controller if the return air temperature sensor is disconnected. The temperature is measured with a 10k ohm NTC thermistor.

This sensor can be verified and adjusted by:

1. Press MENU key to go to the Main Menu screen.
2. Press UP or DOWN keys and ENTER key to enter TECHNICIAN password 1313.
3. Press UP or DOWN keys to scroll to **I/O Config**; press ENTER key.
4. Press UP or DOWN keys to scroll to **Analog Inputs**; press ENTER key.
5. Press UP or DOWN keys to scroll to **Analog Ins 1/19**.
6. Verify the measurement displayed on screen is accurate (see Figure 12).
7. If the measurement needs to be adjusted, apply an offset value by pressing ENTER to scroll to **Offset**.
8. Press UP or DOWN keys to adjust the offset.
9. The update will not take effect until the cursor is moved out of the **Offset** parameter.
10. Once adjusted, press the ESCAPE key several times to return to Main Menu screen.

**FIGURE 12**  
Adjusting Return Air Temperature Sensor

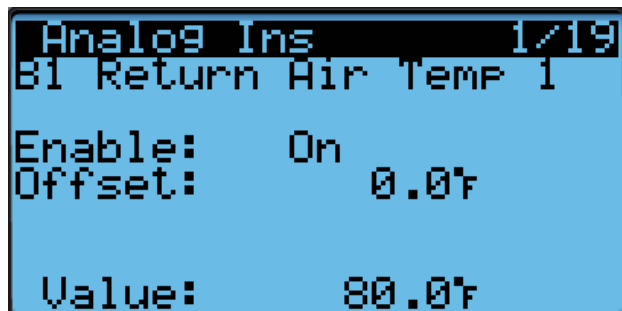

#### Return Air Temperature Alarm

When the return air temperature sensor value is out of range (-41.0 to 303.0°F), the controller will generate a sensor failure alarm to indicate the sensor is not working properly.

This alarm is fixed and cannot be adjusted.

#### Temperature Control Operation

The unit utilizes differentials while in orphan mode to control the space temperature. The differential values all reference the setpoint therefore allowing the control band to be easily changed using the setpoint. To change specific staging characteristics, each differential can be modified individually. There are separate setpoints and differentials for cooling and heating. Specific to the cooling differentials, the economizer will always be utilized first on a cooling call unless outdoor conditions are not acceptable for free cooling. In this case, the compressor will be activated at stage 1 in place of the economizer. All remaining stages will be shifted until the economizer becomes available again.

To change or view the unit setpoint:

1. From the Status screen, press UP or DOWN key until Quick Menu displays Setpoints icon (  ). Press ENTER key.
2. Press ENTER key to scroll to **Cool Setpoint** or **Heat Setpoint** (see Figure 4 on page 8).
3. Press UP or DOWN keys to change the value to desired heating and/or cooling setpoint.

### Orphan Mode

MEGA-TEC Series wall-mount units have the capability to run without the LC6000 controller attached—this feature is called orphan mode. This keeps the shelter between 60°F and 77°F (factory default settings) by the use of the factory-installed return air sensor in each wall-mount unit. In orphan mode, no auxiliary temperature measurement devices are required for operation. The wall-mount unit automatically uses a continuous blower setting to circulate room air into the return air inlet and uses the return air temperature sensor to control room temperature.

If at any time the wall-mount unit(s) loses communication with the LC6000 controller, the wall-mount unit(s) will go into orphan mode and operate using the last communicated setpoints.

To change default setpoints, refer to **Setpoints** on page 8.

During installation, the ability to run in orphan mode allows deactivation of one of the existing, older wall-mount units, while keeping the shelter cool with the other unit still operating. Once the first of the Bard wall-mount units is installed and powered on, it will

operate in orphan mode—keeping the climate inside the shelter stable and the installers comfortable while the remainder of the older equipment is removed and the remaining Bard wall-mount units and LC6000 controller are installed.

Additionally, should any or all of the MEGA-TEC Series wall-mount units lose communication with the LC6000 controller (such as during maintenance), they will continue to serve the shelter’s needs until a repair can be made.

### LC6000 Control

When the unit is connected to a LC6000 supervisory controller, the cooling and heating stages will be controlled by the LC6000. For more information on LC6000 staging, see latest version of LC6000 Service Instructions 2100-669.

### Cooling (with Economizer)

If equipped with an economizer, the unit is equipped with 1 stage of free cooling and 3 stages of mechanical cooling for a total of 4 cooling stages (see Figure 13).

### Cooling (without Economizer)

In a situation where the unit is either not equipped with an economizer or is equipped with an economizer but the outdoor conditions are not favorable for economizer operation, the staging will use Stage 1, 2 or 3 differentials (see Figure 14 on page 14).

### Heating

The unit can be equipped with 0, 1 or 2 stages of electric heat (see Figure 15 on page 14).

**FIGURE 13**  
**Cooling (with Economizer)**

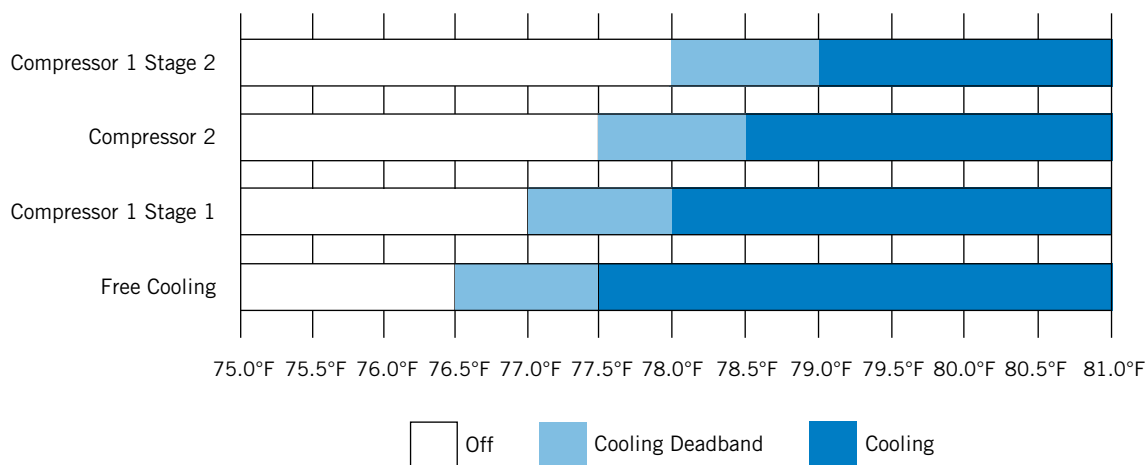

**FIGURE 14**  
**Cooling (without Economizer)**

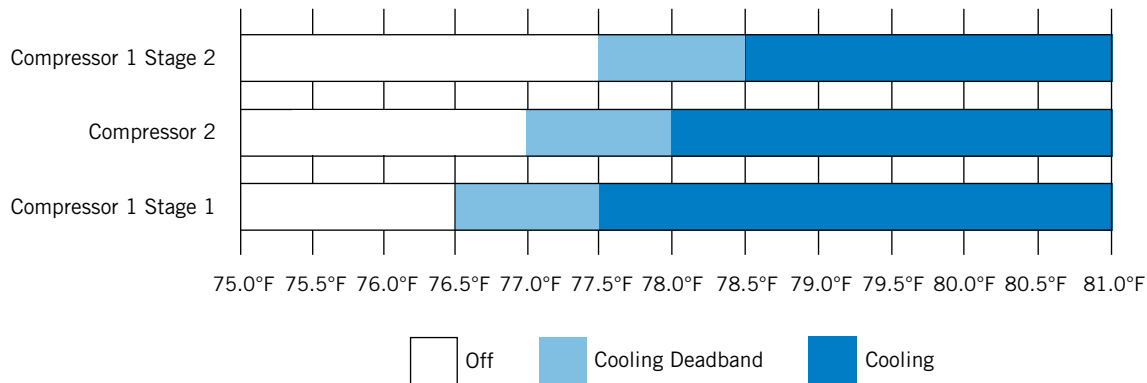

**FIGURE 15**  
**Heating**

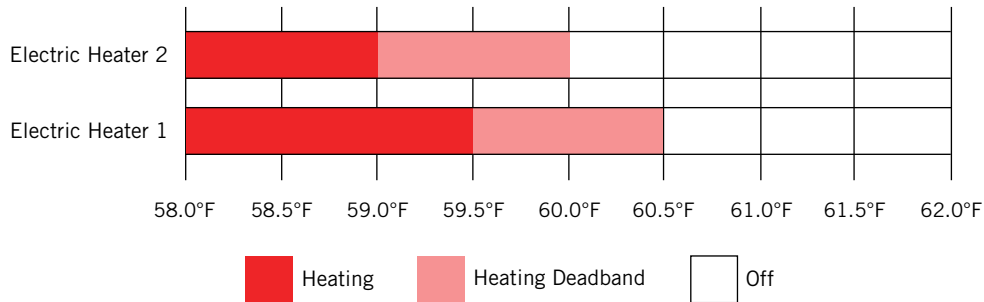

## Electronic Expansion Valve (EEV)

### EEV Components

#### Electronic Expansion Valve

The electronic expansion valve is a stepper motor that is controlled with a step output from the controller. The valve is capable of 480 steps represented by a 0-100% signal on the controller. The motor drives a needle valve that regulates the flow of refrigerant.

#### EEV Instructions for Vacuum, Reclaim, Charge Unit

The electronic expansion valve moves to the 20% open position when the unit is not actively cooling. The valve may need to be manually positioned for service or troubleshooting. The valve can be positioned by using a menu override.

To manually override the valve:

**NOTE:** The unit must be off to perform this override.

1. Press MENU key to go to the Main Menu screen.
2. Press UP or DOWN keys and ENTER key to enter TECHNICIAN password 1313.
3. Press UP or DOWN keys to scroll to **I/O Config**; press ENTER key.

4. Press UP or DOWN keys to scroll to **Manual EEV**; press ENTER key.
5. Press UP or DOWN keys to scroll to **EEV Circuit 1** or **EEV Circuit 2**.
6. Press ENTER key to scroll to **Service Pos** (see Figure 16).
7. Press UP or DOWN keys to adjust to the desired value.
8. Press ENTER key to scroll to **Enable**.
9. Press UP or DOWN key to change **Off** to **On**.
10. Press ENTER key to save.

**FIGURE 16**  
**Overriding EEV Output**

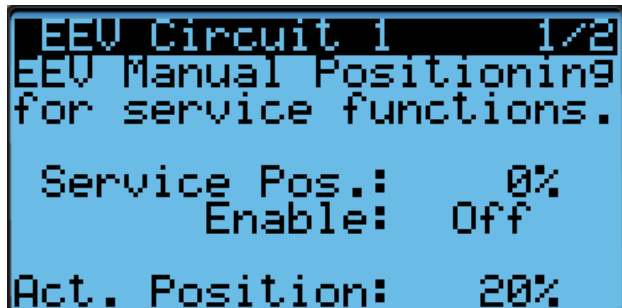

The valve can also be opened or closed using the EEV service tool (Bard Part # 2151-021). This magnetic EEV service tool (shown in Figure 17) is used to manually open the EEV. To do this, remove the EEV stator coil (red color with retaining nut on top), slide the magnetic tool over the shaft where the stator was removed and turn in a clockwise direction to open the valve to the full open position (directional arrows are provided on the tool). Opening the valve to the full open position will aid in the refrigerant reclamation and evacuation processes.

With the stator removed, the resistance should be 40 ohms +/- 10%. There are two sets of three wires that will have this resistance.

After removing the EEV service tool, reapply the EEV stator coil and retaining nut. Upon powering the unit back up, the control board will automatically drive the EEV back to the fully shut position, and then back to the 20% open position prior to starting the compressor back up. Once the compressor starts, the control board will again modulate the EEV position to control the system superheat.

**FIGURE 17**  
**Electronic Expansion Valve (EEV) and Service Tool**

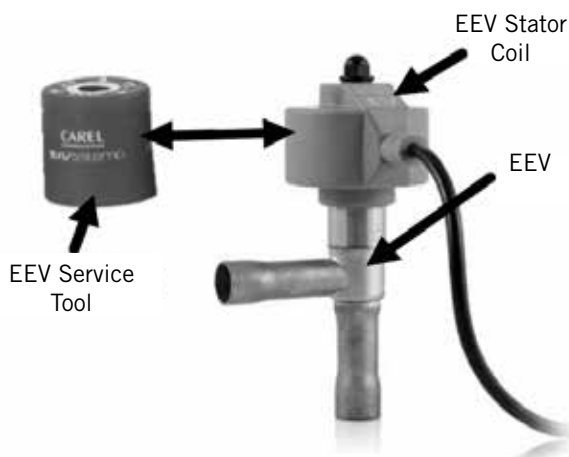

### System Pressures

To view system pressure and temperatures during this process:

1. From the Status screen, press UP or DOWN key until Quick Menu displays Unit Information icon (  ). Press ENTER key.
2. Press UP or DOWN keys to scroll to **A/C Circuit 1 Info** and **A/C Circuit 2 Info** screens (see A/C Circuit Measurements on page 8).

### Suction Pressure Transducer

The unit has pressure transducers installed on the suction line between the evaporator coil and compressor (one on refrigerant circuit 1 and one on refrigerant circuit 2). The transducer is used for system monitoring of suction system pressures. The sensor is

used with the suction temperature sensor to provide a real time superheat calculation that determines the EEV position.

This sensor can be verified and adjusted by:

1. Press MENU key to go to the Main Menu screen.
2. Press UP or DOWN keys and ENTER key to enter TECHNICIAN password 1313.
3. Press UP or DOWN keys to scroll to **I/O Config**; press ENTER key.
4. Press UP or DOWN keys to scroll to **Analog Inputs**; press ENTER key.
5. Press UP or DOWN keys to scroll to **Analog Ins 6/19** (for circuit 1) or **Analog Ins 8/19** (for circuit 2).
6. Verify the measurement displayed on screen is accurate (see Figure 18).
7. If the measurement needs to be adjusted, apply an offset value by pressing ENTER to scroll to **Offset**.
8. Press UP or DOWN keys to adjust the offset.
9. The update will not take effect until the cursor is moved out of the **Offset** parameter.
10. Once adjusted, press the ESCAPE key several times to return to Main Menu screen.

**FIGURE 18**  
**Adjusting Suction Sensor/Transducer Pressure Values**

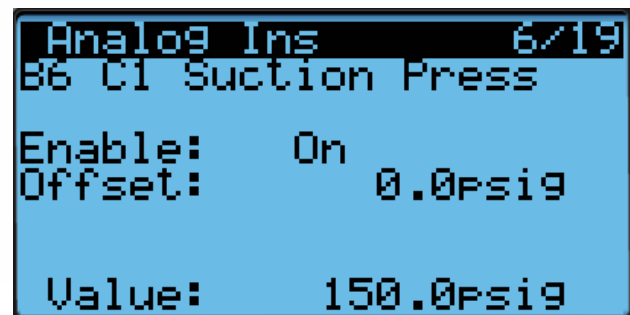

### Troubleshooting the Suction Pressure Transducer

0-250 psig

-5v Nominal, .5 – 4.5v Actual

4v/250 psig = .016 volts per 1 psig

*Example:* 125 psig x .016 + .5 volts = 2.5 volts

Formula for Tech:

Measured Pressure x .016 + Voltage Offset = Expected Transducer Signal Voltage (see Figure 19 on page 16).

**FIGURE 19**  
Voltage to Pressure: Suction Pressure Transducer

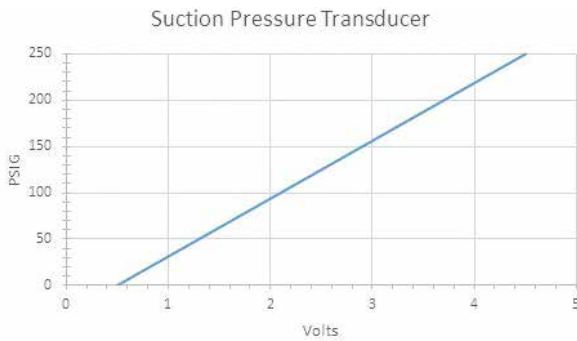

**Suction Pressure Alarm**

When the suction pressure transducer value is measured out of range (0-250 PSIG) and the compressor has been operating for longer than 1 minute, the controller will generate a sensor failure alarm to indicate the sensor is not working properly.

This alarm cannot be adjusted.

**Suction Temperature Sensor**

The suction temperature sensor is used to calculate superheat. The EEV uses this value to control the EEV. The temperature is measured with a 10k ohm NTC thermistor.

The suction temperature sensor measurement can be verified and adjusted by:

1. Press MENU key to go to the Main Menu screen.
2. Press UP or DOWN keys and ENTER key to enter TECHNICIAN password 1313.
3. Press UP or DOWN keys to scroll to **I/O Config**; press ENTER key.
4. Press UP or DOWN keys to scroll to **Analog Inputs**; press ENTER key.
5. Press UP or DOWN keys to scroll to **Analog Ins 10/19** (for circuit 1) or **Analog Ins 11/19** (for circuit 2).
6. Verify the measurement displayed on screen is accurate (see Figure 20).
7. If the measurement needs to be adjusted, apply an offset value by pressing ENTER to scroll to **Offset**.
8. Press UP or DOWN keys to adjust the offset.
9. The update will not take effect until the cursor is moved out of the **Offset** parameter.

**FIGURE 20**  
Adjusting Suction Temperature Sensor Values

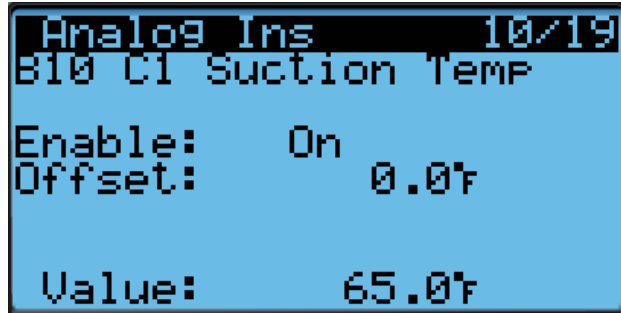

**Suction Temperature Alarm**

When the suction temperature sensor value is out of range (-41.0 to 303.0°F), the controller will generate a sensor failure alarm to indicate the sensor is not working properly.

This alarm cannot be adjusted.

**Evaporator Freeze Condition Alarm**

The freeze condition alarm uses a temperature sensor attached to the evaporator coil to determine if the evaporator is cold enough to potentially start building ice. The controller will generate this alarm when the compressor is running and the coil temperature is below 32°F for 2 minutes. While the alarm is active, the compressor will be deactivated and the blower speed will be set to 80%. The evaporator temperature needs to warm back up to the reset temperature of 55°F for 5 minutes before the alarm will clear and the compressor will be permitted to run again.

The evaporator freeze sensor measurement can be verified and adjusted by:

1. Press MENU key to go to the Main Menu screen.
2. Press UP or DOWN keys and ENTER key to enter TECHNICIAN password 1313.
3. Press UP or DOWN keys to scroll to **I/O Config**; press ENTER key.
4. Press UP or DOWN keys to scroll to **Analog Inputs**; press ENTER key.
5. Press UP or DOWN keys to scroll to **Analog Ins 13/19** (for circuit 1) or **Analog Ins 14/19** (for circuit 2).
6. Verify the measurement displayed on screen is accurate (see Figure 21).
7. If the measurement needs to be adjusted, apply an offset value by pressing ENTER to scroll to **Offset**.
8. Press UP or DOWN keys to adjust the offset.
9. The update will not take effect until the cursor is moved out of the **Offset** parameter.



**FIGURE 21**  
Adjusting Evaporator Freeze Sensor Values

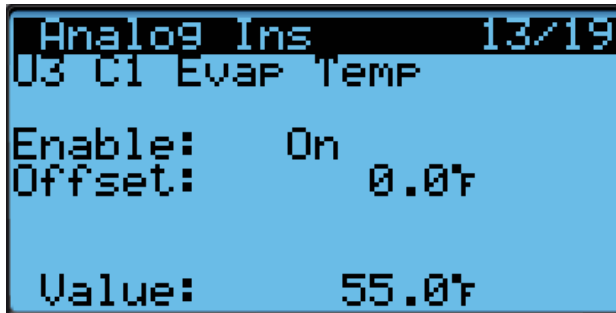

### EEV Operation

#### EEV Superheat Control

The electronic expansion valve (EEV) will open or close to maintain 10° of superheat while the compressor is running. When the compressor is not running, the valve will close to the 20% open default position.

Low superheat protection will be active once the superheat value is at or below 5°F. At this point, the control will aggressively close the valve so that superheat is maintained.

#### Additional EEV Alarms

##### Low Superheat Alarm

This alarm will become active when the calculated superheat goes below 5°F. This alarm will clear itself when the condition is no longer present.

This alarm cannot be adjusted.

### Indoor Airflow

#### Indoor Airflow Components

##### Blower

The unit is equipped with a blower that is driven by an electronically commutated motor (ECM). The blower is controlled by a 0-100% signal through Modbus communication. The motor controller converts this signal to a PWM signal. The blower on the W120AP model uses a 22" (560 mm) diameter wheel and operates between 550-1150 rpm.

The blower output can be put into an override mode for verification or troubleshooting.

To put the blower into override:

1. Press MENU key to go to the Main Menu screen.
2. Press UP or DOWN keys and ENTER key to enter TECHNICIAN password 1313.
3. Press UP or DOWN keys to scroll to **I/O Config**; press ENTER key.
4. Press UP or DOWN keys to scroll to **Fans / Blowers**; press ENTER key.

5. Press UP or DOWN keys to scroll to **Blower 1**.
6. Press ENTER key to scroll to **Blower Overrides?** (see Figure 22).
7. Press UP or DOWN key to change **No** to **Go**. The override will begin and the screen will change to the override screen (see Figure 22).

The override will last for 5 minutes or until the **Fan Overrides** parameter is set to **No** again.

**FIGURE 22**  
Putting Blower Output into Override Mode

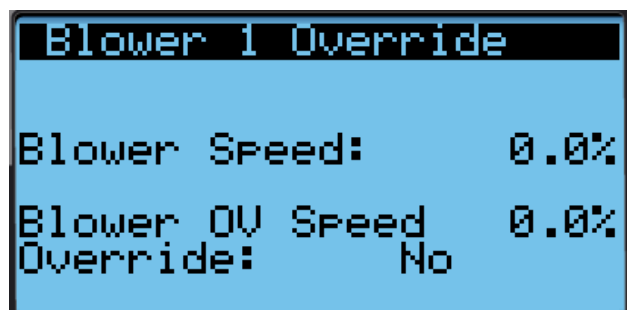
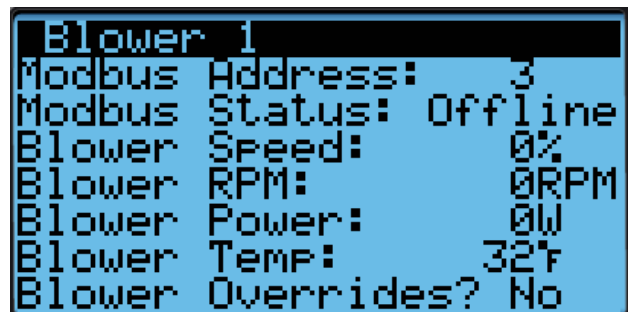

**TABLE 3**  
Rated Airflow

	Nominal Rated CFM		Nominal Rated ESP
	High	Low	
W120AP	4000	2800	0.30

**TABLE 4**  
Indoor Blower Performance

	ESP (Inch H <sub>2</sub> O)	Dry Coil	Wet Coil
W120AP	0.30	4160	3890

**TABLE 5**  
**Maximum ESP of Operation**  
**Electric Heat Only**

Model	Static Pressure*
-B0Z	.50"
-B09	.50"
-B18	.50"
-C0Z	.50"
-C09	.50"
-C18	.50"

\* Unit is rated for free blow non-ducted operation with SG-10W Supply Grille and RG-10W Return Grille.

### Blower Status Switch

The unit is equipped with a differential pressure airflow switch to monitor the blower (see Figure 23). If the blower is turned on and the switch doesn't close to indicate there is differential pressure between the inlet and outlet of the blower, an alarm will be generated. For switch settings, see Figure 23.

Differential airflow status can be viewed by:

1. Press MENU key to go to the Main Menu screen.
2. Press UP or DOWN keys and ENTER key to enter TECHNICIAN password 1313.
3. Press UP or DOWN keys to scroll to **I/O Config**; press ENTER key.
4. Press UP or DOWN keys to scroll to **Digital Inputs**; press ENTER key.
5. Reference **Airflw 1** row and **Val** column (see Figure 24).

**FIGURE 23**  
**Dirty Filter Switch and Blower Status Switch**

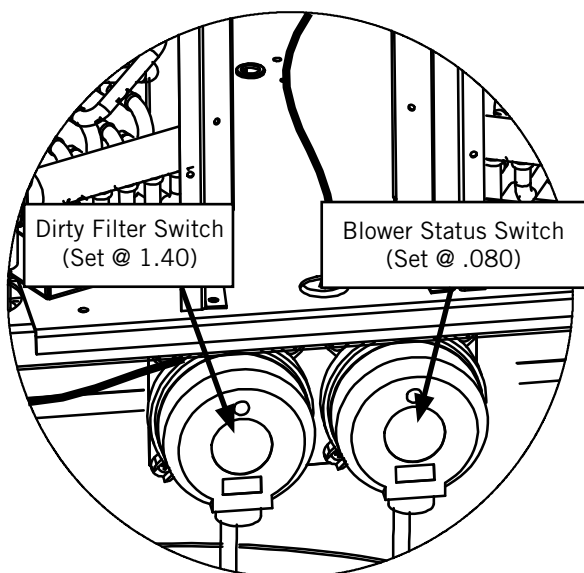

**FIGURE 24**  
**Verifying Differential Airflow Status**

Digital Ins			1/2
Channel	En	Dir	Val
Disable	Yes	N/C	Off
CCM1	Yes	N/O	Off
CCM2	Yes	N/O	Off
Airflw 1	Yes	N/O	On
Airflw 2	No	N/O	On
Filter 1	Yes	N/O	Off

### Blower Status Alarm

When the blower is on for 45 seconds and no airflow is detected by the airflow switch, the compressor and heating operations will be disabled. The system will wait 5 minutes before trying again. After three consecutive no airflow events, the system will generate an alarm and lockout requiring a user reset.

### Filters

The unit is equipped with four (4) 20" x 24" x 2" MERV 8 filters (two per coil). The filters lift and slide into position making them easy to service. The filters can be serviced by opening the "hinged" front access panel and locking it into position. Then lift and slide into position as needed.

### Dirty Filter Switch

These units are equipped with a differential pressure switch to indicate when the filter(s) needs to be replaced (see Figure 23). The dirty filter switch measures the pressure difference across the filter through silicone tubing routed to the blower and evaporator areas of the unit.

The switch circuit consists of a *normally open* filter pressure switch. The switch will open when the pressure differential goes above the setting indicated on the dial. When the pressure difference returns below the setting on the dial, the switch will close.

Adjustment of dirty filter switch may be necessary to ensure proper operation. See Figure 25 to aid in setting the filter switch to operate at different percentages of filter blockage.

### Dirty Filter Alarm

The wall-mount unit is equipped with a differential pressure switch input to the controller. When the switch indicates a dirty filter, the controller will generate an alarm. The alarm will latch once triggered requiring a technician to acknowledge the alarm after replacing filters. Additionally, an indicator light will be turned on with the alarm and turned off when the alarm clears.

The threshold of this alarm is adjusted by changing the settings on the switch (see Figure 25).

**FIGURE 25**  
**Dirty Filter Switch and Filter Indicator Light**

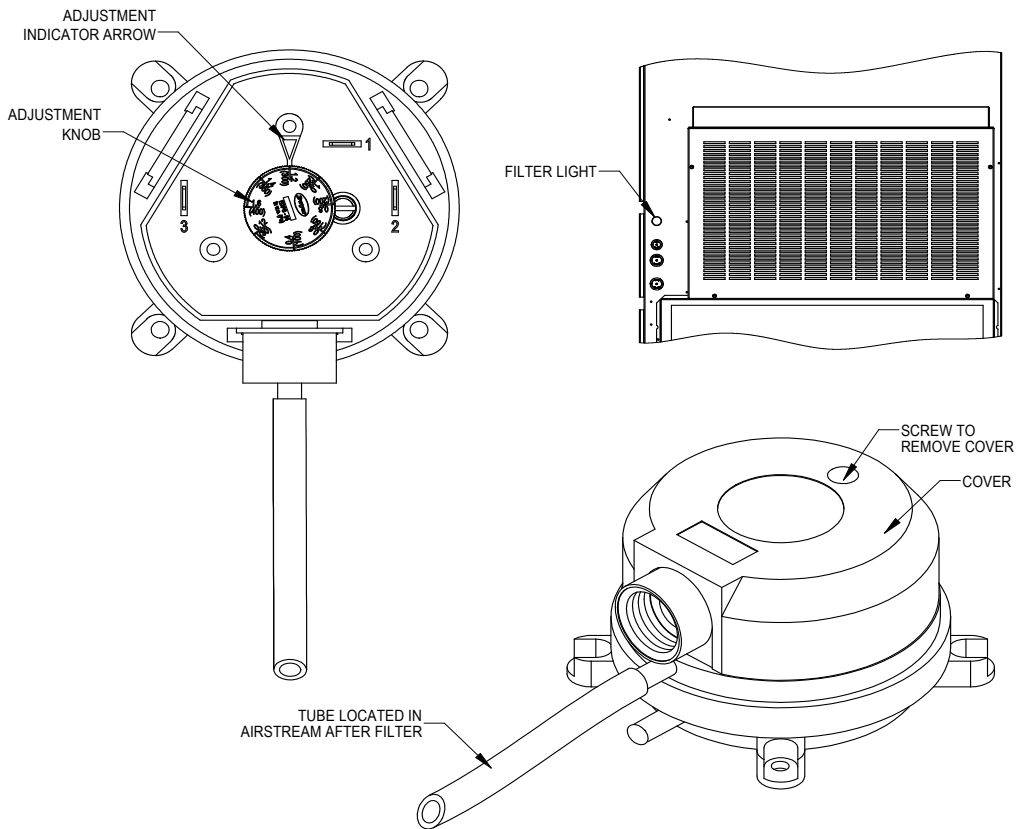

MIS-3952

### **Filter Indicator Light**

The wall-mount unit is equipped with a 24v indicator light mounted on side of unit that displays the current status of the filter (see Figure 25). When the light is on, the filter needs to be replaced. Once the filter(s) has been changed and the alarm has been cleared, the indicator light will turn off.

### **Indoor Airflow Operation**

#### **Blower Speed Control**

The blower is capable of changing speeds to best match the requirements of the system depending on which mode the system is in.

The unit will automatically switch to the required speed for each mode. High sensible mode and dehumidification mode are both communicated separately from the LC. For more information on the high sensible command from LC, please see LC6000 Service Instructions 2100-669.

### **Additional Indoor Airflow Alarms**

#### **Supply Air Temperature Alarm**

When the supply air temperature sensor value is out of range (-41.0 to 303.0°F), the controller will generate a sensor failure alarm to indicate the sensor is not working properly.

This alarm is fixed and cannot be adjusted.

### **Condenser Fan**

#### **Condenser Fan Components**

#### **Condenser Fan**

The unit is equipped with a condenser fan that is driven by an electronically commutated motor (ECM). This fan is controlled by a 0-100% command using modbus serial communication. The fan operates between 100-1200 rpm.

To enable fan override:

1. Press MENU key to go to the Main Menu screen.
2. Press UP or DOWN keys and ENTER key to enter TECHNICIAN password 1313.

3. Press UP or DOWN keys to scroll to **I/O Config**;  
press ENTER key.
4. Press UP or DOWN keys to scroll to **Fans / Blowers**;  
press ENTER key.
5. Press UP or DOWN keys to scroll to **Condenser Fan 1** (see Figure 26).
6. Press ENTER key to scroll to the **Fan Overrides?**
7. Press UP or DOWN keys to change the value from **No** to **Go**. The override will begin and the screen will change to the override screen (see Figure 26).

The override will last for 5 minutes or until the **Fan Overrides** parameter is set to **No** again.

**FIGURE 26**  
Enabling Fan Override

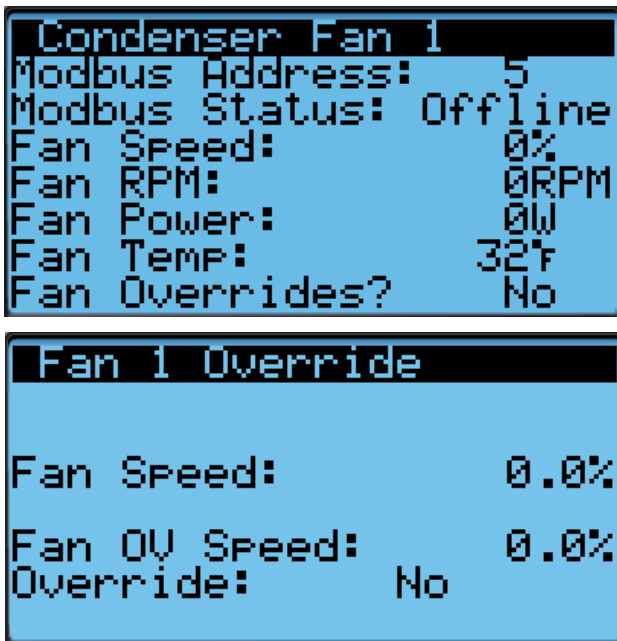

**Liquid Pressure Sensor**

The unit has a pressure transducer installed on the liquid line between the condenser and electronic expansion valve (EEV). The transducer is used for condenser fan speed control and for monitoring of system operation. The liquid line transducer is also referred to as the discharge pressure sensor.

The discharge/liquid pressure sensor input can be verified and adjusted by:

1. Press MENU key to go to the Main Menu screen.
2. Press UP or DOWN keys and ENTER key to enter TECHNICIAN password 1313.
3. Press UP or DOWN keys to scroll to **I/O Config**;  
press ENTER key.
4. Press UP or DOWN keys to scroll to **Analog Inputs**;  
press ENTER key.

5. Press UP or DOWN keys to scroll to **Analog Ins 7/19** (for circuit 1) or **Analog Ins 9/19** (for circuit 2).
6. Verify the measurement displayed on screen is accurate (see Figure 27).
7. If the measurement needs to be adjusted, apply an offset value by pressing the ENTER key to scroll to **Offset**.
8. Press UP or DOWN keys to adjust the offset. The update will not take effect until the cursor is moved out of the offset parameter.
9. Once adjusted, the ESCAPE key several times to return to Main Menu screen.

**FIGURE 27**  
Adjusting Discharge/Liquid Transducer Pressure Values

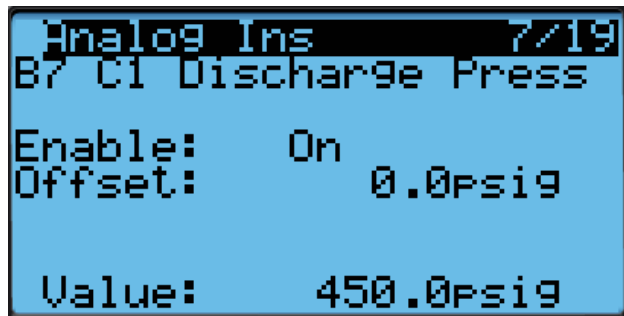

*Troubleshooting the Discharge/Liquid Pressure Transducer*

0-650 psig  
.5 to 4.5v  
4.5-.5 + 4 volt range/650 psig = .00615 volts per 1 psig

*Example:* 325 psig x .00615 + .5 v = 2.5 volts

Formula for Tech:  
Measured Pressure x .00615 + Voltage Offset =  
Expected Transducer Signal Voltage (see Figure 28).

**FIGURE 28**  
Voltage to Pressure:  
Discharge/Liquid Pressure Transducer

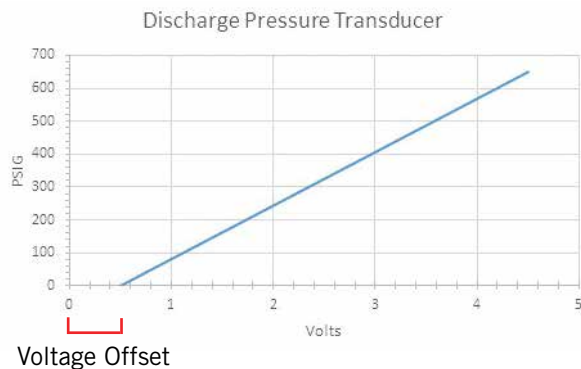

### ***Discharge/Liquid Pressure Transducer Alarm***

When the discharge pressure sensor value is out of range (0-650 PSIG), the controller will generate a sensor failure alarm to indicate the sensor is not working properly.

This alarm is fixed and cannot be adjusted.

### **Liquid Temperature Sensor**

The unit is equipped with a liquid line temperature sensor to monitor the temperature of the liquid refrigerant leaving the condenser and entering the EEV. The temperature is measured with a 10k ohm NTC thermistor.

The liquid temperature sensor can be verified and adjusted by:

1. Press MENU key to go to the Main Menu screen.
2. Press UP or DOWN keys and ENTER key to enter TECHNICIAN password 1313.
3. Press UP or DOWN keys to scroll to **I/O Config**; press ENTER key.
4. Press UP or DOWN keys to scroll to **Analog Inputs**; press ENTER key.
5. Press UP or DOWN keys to scroll to **Analog Ins 16/19** (for circuit 1) or **Analog Ins 17/19** (for circuit 2).
6. Reference the **Value** to verify the temperature (see Figure 29).
7. If an offset needs to be applied, press ENTER key to scroll to **Offset**.
8. Press UP or DOWN keys to change the offset to desired value.
9. Press ENTER key to save.
10. Press ESCAPE key several times to return to Main Menu screen.

**FIGURE 29**  
**Adjusting Discharge/Liquid Temperature Input**

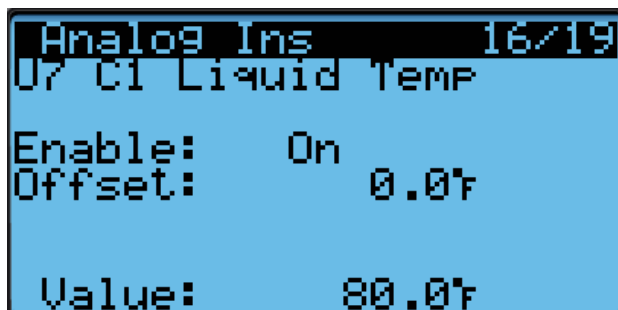

### **Outdoor Temperature Sensor**

The unit is equipped with a combination outdoor temperature and humidity sensor. The temperature is measured with a 10k ohm NTC thermistor. See page 286 for more information.

## **Condenser Fan Operation**

### **Condenser Fan Speed Control**

The fan will speed up or slow down to attempt to maintain a discharge pressure. The unit will allow the discharge pressure setpoint to increase for high ambient scenarios or decrease for low ambient scenarios. Because the control is dependent on the discharge pressure sensor, the controller will alter its operation if the sensor is not enabled or failed. When the liquid pressure transducer is not enabled or considered failed by the controller, a nominal speed of 74% will be used during a compressor call.

## **Compressor**

### **Compressor Components**

#### **Compressor**

#### *Three Phase Scroll Compressor Start Up Information*

Scroll compressors, like several other types of compressors, will only compress in one rotational direction. Direction of rotation is not an issue with single phase compressors since they will always start and run in the proper direction.

However, three phase compressors will rotate in either direction depending upon phasing of the power. Since there is a 50-50 chance of connecting power in such a way as to cause rotation in the reverse direction, verification of proper rotation must be made. Verification of proper rotation direction is made by observing that suction pressure drops and discharge pressure rises when the compressor is energized. Reverse rotation also results in an elevated sound level over that with correct rotation, as well as substantially reduced current draw compared to tabulated values.

Verification of **proper rotation** must be made at the time the equipment is put into service. If improper rotation is corrected at this time, there will be no negative impact on the durability of the compressor. However, reverse operation for over 1 hour may have a negative impact on the bearing due to oil pump out.

**NOTE:** *If compressor is allowed to run in reverse rotation for an extended period of time, the compressor's internal protector will trip.*

All three phase compressors are wired identically internally. As a result, once the correct phasing is determined for a specific system or installation, connecting properly phased power leads to the same Fusite terminal should maintain proper rotation direction.

The direction of rotation of the compressor may be changed by reversing any two line connections to the wall-mount unit.

**Compressor Control Module (CCM)**

- Delay-on-Make Timer
- Short Cycle Protection/Delay-on-Break
- Test Mode
- High Pressure Detection
- Brownout Protection with Adjustment

The LPC terminals are jumpered in this application. Instead, the low pressure transducer is used for low pressure monitoring.

**Delay-on-Make Timer**

In the event of power loss, a delay-on-make timer is included to be able to delay startup of the compressor. This is desired when more than one unit is on a structure so that all of the units do not start at the same time which could happen after a power loss or building shutdown. The delay-on-make time period is 2 minutes plus 10% of the delay-on-break time period. To ensure that all of the units do not start at the same time, adjust the delay-on-break timer on each unit to a slightly different delay time.

**Short Cycle Protection/Delay-on-Break**

An anti-short cycle timer is included to prevent short cycling the compressor. This is adjustable from 30 seconds to 5 minutes via the adjustment knob (see Figure 30). Once a compressor call is lost, the time period must expire before a new call will be initiated.

10% of this time is also considered on the delay-on-make timer (see **Delay-on-Make Timer**).

**High Pressure Detection**

High pressure switch monitoring allows for a lockout condition in a situation where the switch is open. If the high pressure switch opens, the CCM will de-energize the compressor. If the switch closes, it will then restart the compressor after the delay-on-break setting has expired on the device. If the switch trips again during the same Y call, the compressor will be de-energized. The ALR terminal will be energized, signaling the unit control board that a high pressure event has occurred (see **Refrigerant High Pressure Alarm** on page 23).

**FIGURE 30**  
**8201-164 Compressor Control Module**

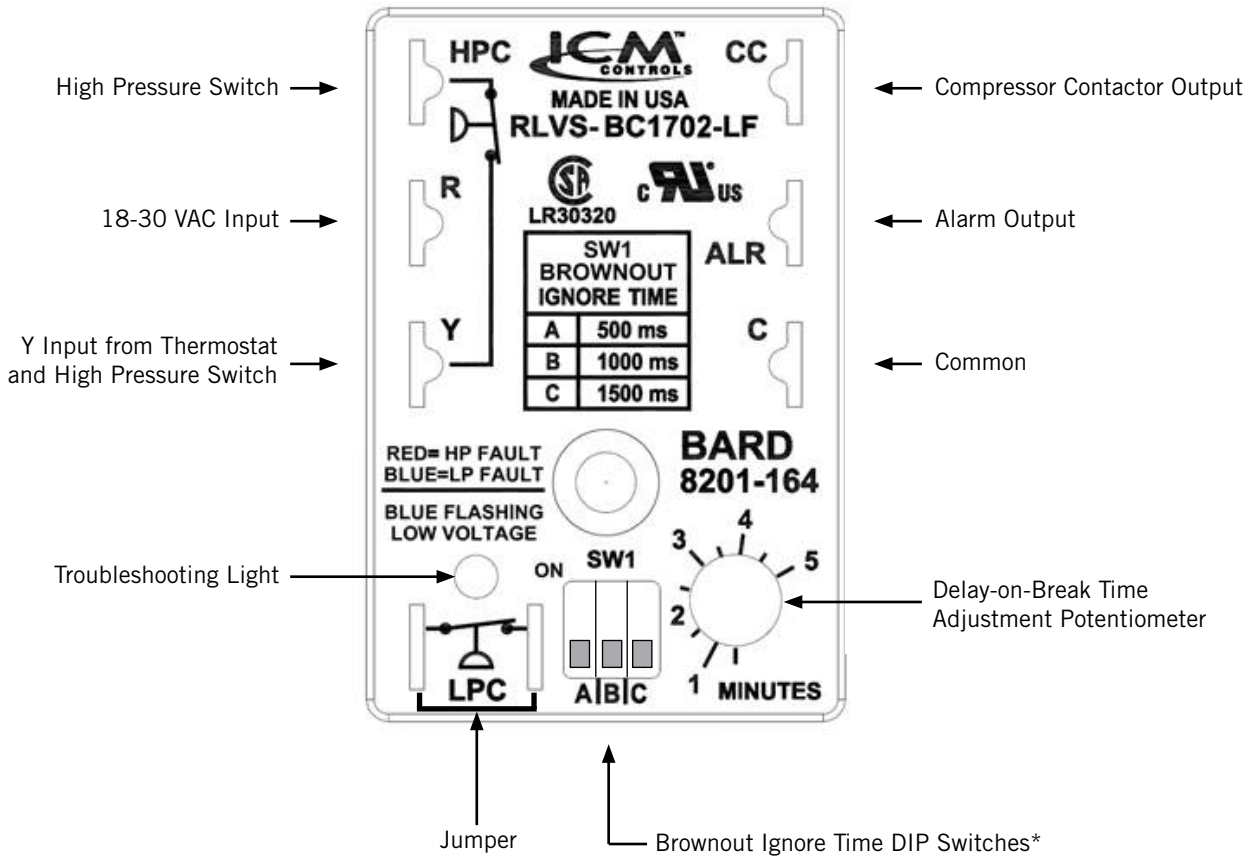

\* Turn on only one switch for that specific ignore time setting

### **Test Mode**

By rapidly rotating the potentiometer (POT) clockwise (see Figure 30), all timing functions will be removed for testing.

The conditions needed for the unit to enter test mode are as follows: POT must start at a time less than or equal to the 40 second mark. The POT must then be rapidly rotated to a position greater than or equal to the 280 second mark in less than ¼ second. Normal operation will resume after power is reset or after the unit has been in test mode for at least 5 minutes.

### **Brownout Protection with Adjustment**

Brownout protection may be necessary if the utility power or generator power has inadequate power to prevent the voltage from dropping when the compressor starts. This is rare but can happen if the generator is undersized at the site or if the site is in a remote location far from the main power grid. Under normal circumstances, allowing the brownout to be ignored for a time period should not be needed. The 8201-164 is shipped with all the DIP switches in the 'off' or 'do not ignore' position (see Figure 30).

If ignoring the brownout is needed because of the above conditions, three preset timers can be set by DIP switches in order to delay signaling a power brownout for a specific length of time after compressor contactor is energized. This allows the compressor a time period to start even if the voltage has dropped and allows the voltage to recover. This delay only happens when the CC terminal energizes. The delay can be set to 500 milliseconds (A DIP switch), 1000 milliseconds (B DIP switch) or 1500 milliseconds (C DIP switch); time is not cumulative—only the longest setting will apply. If the voltage recovers during the brownout time period, the compressor will start.

If a brownout condition is detected by the 8201-164, the troubleshooting light will flash blue. The light will continue to flash until the cooling call is satisfied or power is removed from the Y terminal. This condition does not prevent operation, it only indicates that a brownout condition was present at some point during the cooling call. If a brownout condition is detected, CC will be de-energized and will retry after the delay-on-make timer is satisfied; this process will continue until call is satisfied.

If user chooses the 'do not ignore' position when the site has inadequate utility or generator power, this could lead to the compressor never starting. The control will see the brownout immediately and not start.

A common scenario and one that has been seen in the field is when a unit or units switches from utility power to generator power. With slower transfer switches, the time delay between the utility power and generator power didn't cause a problem. The units lost power, shut off and came back on line normally. With the introduction of almost instantaneous transfer switches,

the millisecond long power glitch can be enough that the compressor will start to run backwards. In this scenario, the CCM will catch this and restart the units normally.

### **High Pressure Safety Switch**

All units have a high pressure switch as a safety device. This device will open when pressure in the system reaches 650 PSIG. The sensor is directly connected to the dedicated compressor control module (see **High Pressure Detection** on page 22).

### **Refrigerant High Pressure Alarm**

When the wall-mount unit receives a signal from the compressor control module (CCM) indicating a high pressure event, the wall-mount unit will generate an alarm. Upon receiving the alarm, the wall-mount unit will remove the "Y" call from the CCM, resetting the status of the CCM. The alarm will stay present on the wall-mount unit until manually cleared with TEC-EYE hand-held diagnostic tool.

In addition to the CCM, the discharge pressure transducer is used to prevent a high pressure event. When the discharge pressure is above the discharge pressure alarm setpoint (set 30 pounds below high pressure switch, which is 650), the system will disable stage 2 of mechanical cooling.

### **Phase Monitor**

Used only on three phase equipment, the phase monitor is a compressor protection device that will prohibit operation of the compressor if the device senses a possible reverse-rotation situation due to incorrect phasing. On a call for compressor (and only compressor), the device will check incoming phase, check for severe voltage imbalance and check for proper frequency. Under nominal conditions, a green LED light will show on the face of the monitor. If there is improper phasing, voltage imbalance or frequency deviation, the device will show a red LED light and prohibit compressor operation.

If a fault condition occurs, reverse two of the supply leads to the unit. **Do not reverse any of the unit factory wires as damage may occur.**

### **Compressor Operation**

The compressor will be enabled when the unit (in orphan mode) or LC provide a cooling stage 1 call. The compressor call from the controller has several delays that may affect the start or stop time of the compressor in regards to the cooling demand. The compressor has a minimum on time of 180 seconds to prevent short cycling the compressor. The compressor also has a minimum off time of 120 seconds to prevent start ups before the pressure in the refrigeration system equalizes. When the second stage is engaged, it also has a minimum run time of 120 seconds to allow the system to stabilize before returning to single stage or shutting down.

These delays can be changed by:

1. Press MENU key to go to the Main Menu screen.
2. Press UP or DOWN keys and ENTER key to enter TECHNICIAN password 1313.
3. Press UP or DOWN keys to scroll to **Adv System Config**; press ENTER key.
4. Press UP or DOWN keys to scroll to **Comp. Safety B2**; press ENTER key.
5. Press ENTER key to scroll to **Min On Time** or **Min Off Time** (see Figure 31).
6. Press UP or DOWN keys to change the value.
7. Press ENTER key to save value and move the cursor to next parameter or top of screen.
8. Press ESCAPE key several times to return to Main Menu screen.

The address-based delay only applies to the wall-mount unit when in orphan mode. The controller will delay the unit compressor based on the value entered on screen B2 multiplied by the unit address. This is intended to keep multiple units from starting their compressors at the same time when there is a quick change in the load. When connected to the LC, this is taken care of by LC logic.

**FIGURE 31**  
**Adjusting Compressor Delays**



### **Additional Compressor Alarms**

#### **Refrigerant Low Pressure Alarm**

When the suction pressure transducer indicates a pressure value less than the low pressure alarm setpoint of 40 PSIG and there is an active call for cooling, the controller will disable the compressor (after a 120-second delay). **NOTE:** *The second call will be delayed based on the delay off value mentioned in the compressor section.* The controller will try to run the refrigeration system two (2) times within 900 seconds before the alarm will lock the compressor out. This alarm needs to be manually cleared before compressor operation will resume.

## **Economizer**

### **Economizer Components**

#### **Actuator**

The actuator rotates up to 90° based on a 2-10v signal sent to it by the controller. This component is what opens and closes the damper blade. The unit is equipped with three dampers powered by three separate actuators. The left intake damper (damper 1) and the right intake damper (damper 3) are each powered by a 44 in-lb actuator. The exhaust damper (damper 2) is powered by a 90 in-lb actuator. All dampers are spring return and will close the damper if power is lost.

To verify the output from the controller to the actuator:

1. Press MENU key to go to the Main Menu screen.
2. Press UP or DOWN keys and ENTER key to enter TECHNICIAN password 1313.
3. Press UP or DOWN keys to scroll to **Analog Outputs**; press ENTER key.
4. Press UP or DOWN keys to scroll to **Damper System 1/5**.
5. To override the current position, press ENTER key to scroll to **System OV Pos** (see Figure 32).
6. Press UP or DOWN keys to change the value to the desired output.
7. Press ENTER key to save the value and move cursor to **Enable Sys. OV**.
8. Press UP or DOWN keys to change the value from **No** to **Yes**.
9. The damper position will update with the new override value and the damper will travel to that position.

**NOTE:** *This override will last for 5 minutes or until the **Enable Sys. OV** is changed back to **No**.*

**FIGURE 32**  
**Damper Override**

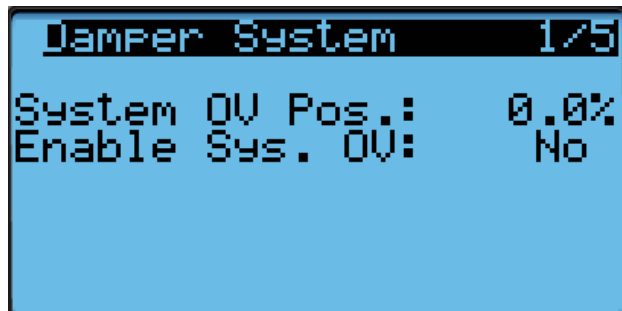



## Dust Sensor

The unit has a dust sensor installed near the outdoor air inlet. The dust sensor checks for excessive particulates in the outdoor air, and will close the economizer if the dust is excessive. The sensor uses a PWM signal converted to 0-5v output to the controller.

To ensure proper performance, cleaning may be required. Vacuuming or blowing the dust off the sensor with forced air is recommended. **Avoid inserting any objects into the sensor.**

The dust sensor can be verified by:

1. Press MENU key to go to the Main Menu screen.
  2. Press UP or DOWN keys and ENTER key to enter TECHNICIAN password 1313.
  3. Press UP or DOWN keys to scroll to **I/O Config**; press ENTER key.
  4. Press UP or DOWN keys to scroll to **Analog Inputs**; press ENTER key.
  5. Press UP or DOWN keys to scroll to **Analog Ins 15/19**.
  6. Reference the **Value** for the current sensor reading (see Figure 33).
  7. To apply an offset to the current reading, press ENTER key to scroll to **Offset**.
  8. Press UP or DOWN keys to adjust the value to the desired value.
  9. Press ENTER key to save the value and move cursor to next parameter.
- NOTE:** The sensor can be disabled if required for troubleshooting.
10. With the cursor on the **Enable** parameter, press UP or DOWN keys to change the value from **On** to **Off**.
  11. Press ENTER key to save.

**FIGURE 33**  
Dust Sensor

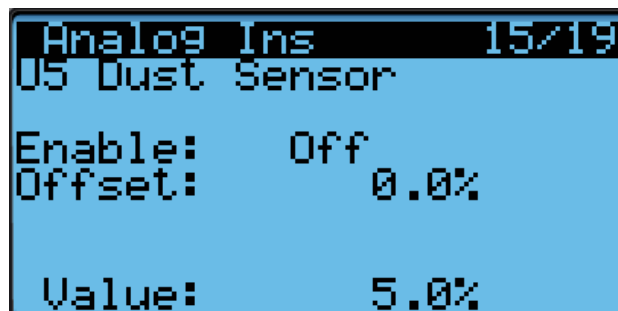

## Dust Sensor Failure Alarm

When the sensor reads a value that is outside of the acceptable 0 to 100% range, an alarm will be generated indicating the sensor has failed. This alarm is just a notification and will not disable any other features on the controller.

This alarm is fixed and cannot be adjusted.

## High Dust Limit Alarm

When dust content in the air is high and is a risk to prematurely reducing airflow through the filters, the unit will restrict the use of the economizer. The controller has adjustable software setpoints to indicate dust levels are too high and to disable the economizer operation for 5 minutes. Once the conditions are no longer present, the alarm will automatically clear.

To adjust the dust sensor alarm setpoint:

1. Press MENU key to go to the Main Menu screen.
2. Press UP or DOWN keys and ENTER key to enter USER password 2000.
3. Press UP or DOWN keys to scroll to **System Config**; press ENTER key.
4. Press UP or DOWN keys to scroll to **Dust Configuration A4**.
5. Press ENTER key to scroll to **Alarm Set** (see Figure 34).
6. Press UP or DOWN keys to change to the desired value.
7. Press ENTER key to save the value.

**NOTE:** When the temperature outside is measured at or below 0°F, the dust sensor alarm will be disabled to allow economizer operation.

**FIGURE 34**  
Adjusting Dust Sensor Alarm Setpoint

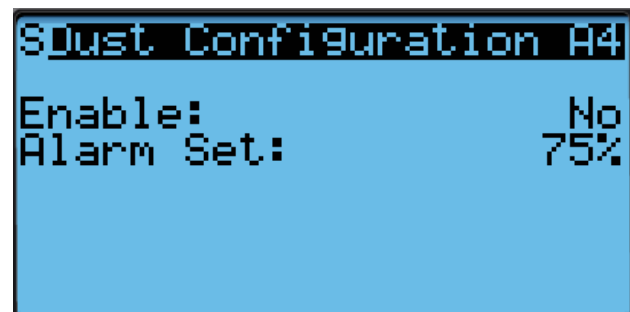

## Damper Blade

The system utilizes three damper blades to bring in outdoor air and exhaust space air for economizer operation. Damper 1 is left intake, damper 2 is exhaust and damper 3 is right intake. Damper blades are made of sheet metal and are integrated into the equipment.

To view damper blade position:

1. Press MENU key to go to the Main Menu screen.
2. Press UP or DOWN keys and ENTER key to enter TECHNICIAN password 1313.
3. Press UP or DOWN keys to scroll to **I/O Config**; press ENTER key.
4. Press UP or DOWN keys to scroll to **Analog Outputs**; press ENTER key.
5. Press UP or DOWN keys to scroll to **Damper Intake Lt 2/5** (see Figure 35), **Damper Intake Rt 3/5** or **Damper Exhaust 1**.

**FIGURE 35**  
**Damper Blade Position**

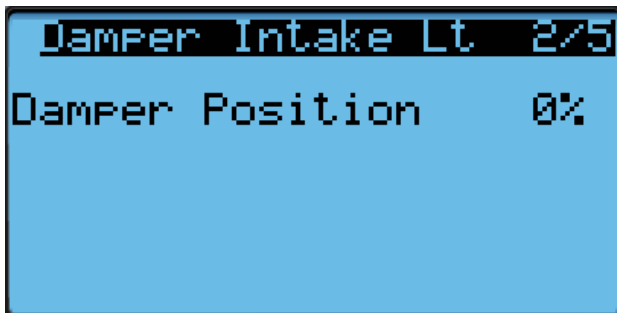

## Damper Switch

The economizer utilizes three magnetic switches (one on each damper blade) to determine if the damper is operating correctly. This switch will be closed when the damper is closed and open when the damper is open.

To verify the status of the switch:

1. Press MENU key to go to the Main Menu screen.
2. Press UP or DOWN keys and ENTER key to enter TECHNICIAN password 1313.
3. Press UP or DOWN keys to scroll to **I/O Config**; press ENTER key.
4. Press UP or DOWN keys to scroll to **Digital Inputs**; press ENTER key.
5. Press UP or DOWN keys to scroll to **Digital Ins 2/2**.
6. Reference the values for **Damper 1**, **Damper 2**, **Damper 3** and **Damper 4** (see Figure 36).
7. The input will display **ON** when the damper is closed (reflecting closed circuit on damper switch) and will display **OFF** when the damper is open (reflecting open circuit on damper switch).

**FIGURE 36**  
**Damper Switch**

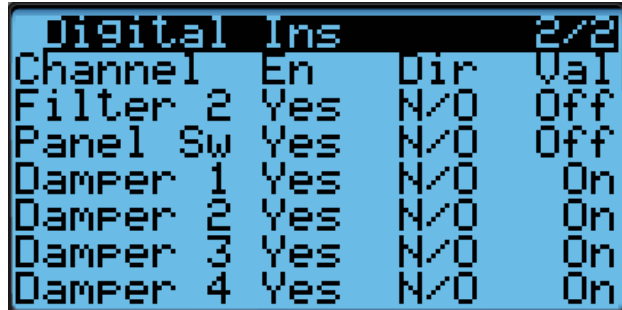
A screenshot of a control panel display showing a table of digital input statuses. The title is "Digital Ins 2/2". The table has four columns: "Channel", "En", "Dir", and "Val".

Channel	En	Dir	Val
Filter 2	Yes	N/O	Off
Panel Sw	Yes	N/O	Off
Damper 1	Yes	N/O	On
Damper 2	Yes	N/O	On
Damper 3	Yes	N/O	On
Damper 4	Yes	N/O	On

### **Damper Failed to Open Alarm**

When the controller commands the economizer damper actuator to a position other than 0% and the damper switch indicates the damper is not open, after a delay of 20 seconds the controller will generate a damper failed to open alarm. This alarm is just a notification and will not disable any features on the controller.

The alarm must be cleared by a user reset.

### **Damper Failed to Close Alarm**

When the controller commands the economizer damper actuator to the 0% position and the damper switch indicates the damper is not closed, after a delay of 300 seconds the controller will generate a damper failed to close alarm. This alarm is just a notification and will not disable any features on the controller.

The alarm must be cleared by a user reset.

## **Outdoor Temperature and Humidity Combination Sensor**

The unit is equipped with a combination outdoor temperature and humidity sensor to monitor outdoor conditions for the economizer operation. The temperature is measured with a 10k ohm NTC thermistor. The humidity is measured with a humidity sensor that outputs a 4-20mA signal to the controller.

The outdoor temperature can be verified by:

1. Press MENU key to go to the Main Menu screen.
2. Press UP or DOWN keys and ENTER key to enter TECHNICIAN password 1313.
3. Press UP or DOWN keys to scroll to **I/O Config**; press ENTER key.
4. Press UP or DOWN keys to scroll to **Analog Inputs**; press ENTER key.
5. Press UP or DOWN keys to scroll to **Analog Ins 4/19**.
6. Reference the **Value** to see the input of the sensor (see Figure 37).
7. To apply an offset, press ENTER key to scroll to **Offset**.
8. Press UP or DOWN keys to change to the desired value.

- Press ENTER key to save the value.

**FIGURE 37**  
**Outdoor Temperature Sensor**

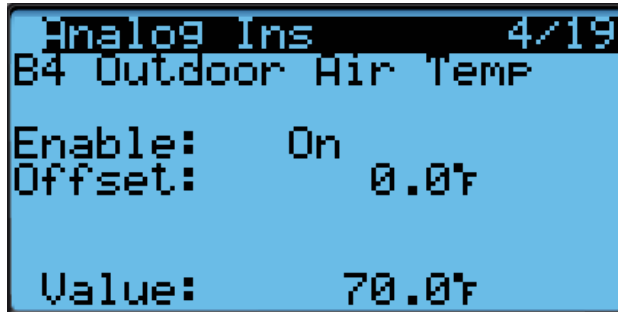

The outdoor humidity can be verified by:

- Press MENU key to go to the Main Menu screen.
- Press UP or DOWN keys and ENTER key to enter TECHNICIAN password 1313.
- Press UP or DOWN keys to scroll to **I/O Config**; press ENTER key.
- Press UP or DOWN keys to scroll to **Analog Inputs**; press ENTER key.
- Press UP or DOWN keys to scroll to **Analog Ins 5/19**.
- Reference the **Value** to see the input of the sensor (see Figure 38).
- To apply an offset, press ENTER key to scroll to **Offset**.
- Press UP or DOWN keys to change to the desired value.
- Press ENTER key to save the value.

**FIGURE 38**  
**Outdoor Humidity Sensor**

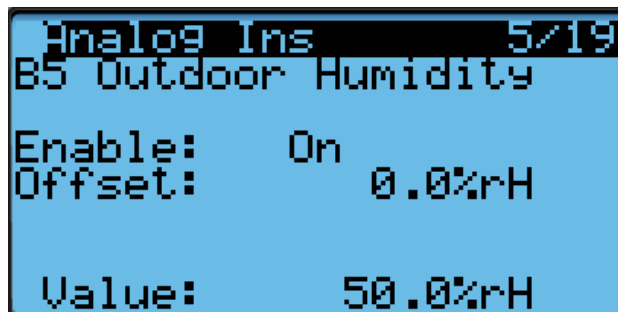

**Outdoor Temperature Sensor Failure Alarm**

When the sensor reads a value that is outside of the acceptable -41 to 303.0° range, an alarm will be generated indicating the sensor has failed. This alarm condition will disable the economizer.

This alarm is fixed and cannot be adjusted.

**Outdoor Humidity Sensor Failure Alarm**

When the sensor reads a value that is outside of the acceptable 0 to 100% RH range, an alarm will be generated indicating the sensor has failed. This alarm condition will disable the economizer when the mode is set to temperature and humidity or enthalpy.

This alarm is fixed and cannot be adjusted.

**Mixed Air Temperature Sensor**

The unit is equipped with a mixed air temperature sensor to monitor the mixed air temperature. The mixed air is measured where the economizer mixes return air and outdoor air. This measurement is used to determine if the economizer is controlling correctly. The sensor is a 10k ohm NTC Thermistor.

The mixed air temperature can be verified by:

- Press MENU key to go to the Main Menu screen.
- Press UP or DOWN keys and ENTER key to enter TECHNICIAN password 1313.
- Press UP or DOWN keys to scroll to **I/O Config**; press ENTER key.
- Press UP or DOWN keys to scroll to **Analog Inputs**; press ENTER key.
- Press UP or DOWN keys to scroll to **Analog Ins 18/19**.
- Reference the **Value** to see the input of the sensor (see Figure 39).
- To apply an offset, press ENTER key to scroll to **Offset**.
- Press UP or DOWN keys to change to the desired value.
- Press ENTER key to save the value.

**FIGURE 39**  
**Mixed Air Temperature Sensor**

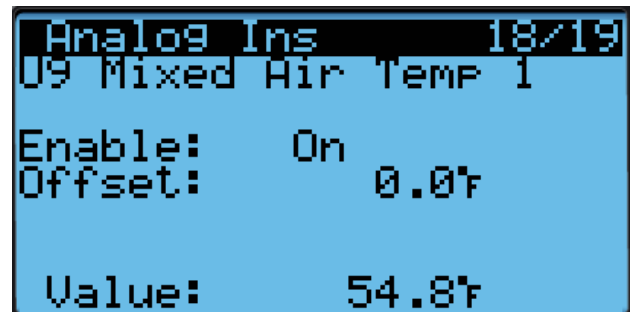

**High Mixed Air Temperature Alarm**

To keep the economizer from bringing in air that is too warm, an alarm will be generated when the mixed air is 2° above the return air temperature for 300 seconds. This alarm will not be generated if the mixed air temperature sensor has failed. The alarm can only be

activated during a free cooling call. The alarm is a user reset and must be cleared by the end user.

### Low Mixed Air Temperature Alarm

To keep the economizer from bringing in air that is too cold, an alarm will be generated when the mixed air temperature is 5°F below the mixed air temperature control setpoint for 300 seconds. If this alarm is active, the economizer will be disabled for the current cooling call. This alarm will reference the mixed air temperature control setpoint to ensure that when the mixed air setpoint changes, the alarm dynamically changes with it. This alarm will not be generated if the mixed air temperature sensor has failed. The alarm can only be activated during a free cooling call and requires a user reset.

### Economizer Operation

The economizer has four types of operation. The first mode is "None" where the economizer is never utilized, except for emergency purposes. The second mode is "Dry Bulb" where the outdoor temperature is the only consideration for economizer use on a free cooling call. The third mode is "TempHum" where the outdoor temperature and humidity are considered for economizer use on a free cooling call. The fourth mode is "Enthalpy" where the outdoor temperature, humidity and calculated dew point are considered for economizer operation on a free cooling call.

To change the economizer type:

1. Press MENU key to go to the Main Menu screen.
2. Press UP or DOWN keys and ENTER key to enter USER password 2000.
3. Press UP or DOWN keys to scroll to **System Config**; press ENTER key.
4. Press UP or DOWN keys to scroll to **Economizer Setup A2**; press ENTER key.
5. Press ENTER key to scroll to **Type** (see Figure 40).
6. Press UP or DOWN keys to change the **Type** desired value to **None**, **Dry Bulb**, **TempHum** or **Enthalpy**.
7. Press ENTER key to save the value and scroll to the next parameter.

**FIGURE 40**  
Economizer Setup

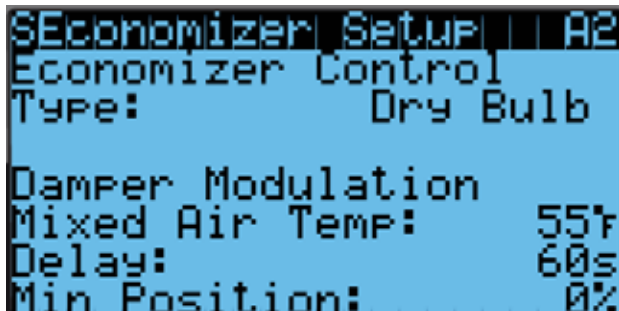

**NOTE:** The following parameters are for the temperature consideration for economizer use. Applies to **Dry Bulb**, **TempHum** and **Enthalpy** type.

8. The cursor should now be on the **Mixed Air Tamp** parameter.
9. Press UP or DOWN keys to change the parameter to the desired value.
10. Press ENTER key to save the value and scroll to the next parameter.
11. The cursor should now be on **Delay** parameter.
12. Press UP or DOWN keys to change the parameter to the desired value.
13. Press ENTER key to save the value and move to the next parameter.
14. The cursor is now on the **Min Position** parameter.
15. Press UP or DOWN keys to change the parameter to the desired value (see **Economizer Operation – Minimum Position** for more information).
16. Press ENTER key to save the value.
17. Press the DOWN key to navigate to the **A3** screen.

**NOTE:** The **A3** screen will not display if economizer mode is set to **None**. Also, the contents of the screen will change depending on which type is chosen: **Dry Bulb** (Figure 41), **TempHum** (Figure 42) or **Enthalpy** (Figure 43). The following menu shows the **Enthalpy** content which also contains parameters that would be shown on **Dry Bulb** (temperature only) and **TempHum** (temperature and humidity only).

18. Press ENTER key to scroll to **OA Temp Set** (on **Drybulb Control** and **Temp/Hum Control A3** screens, this parameter will be titled **Outdoor Set**).
19. Press UP or DOWN keys to change the temperature setpoint to desired value.
20. Press ENTER key to save the value and scroll to **Off Diff**.
21. Press UP or DOWN keys to adjust the outdoor temperature differential for which the economizer is re-enabled.
22. Press ENTER key to save the value and scroll to **OA Hum Set**.
23. Press UP or DOWN keys to adjust the humidity setpoint to desired value.
24. Press ENTER key to save the value and scroll to **On Diff**.
25. Press UP or DOWN keys to adjust the outdoor humidity differential for which the economizer is re-enabled.
26. Press ENTER key to save the value and scroll to **Dew Pt. Set**.

**FIGURE 41**  
Economizer Setup – Dry Bulb Control

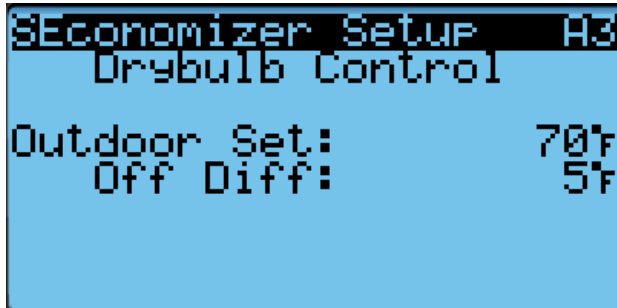

**FIGURE 42**  
Economizer Setup – Temp/Hum Control

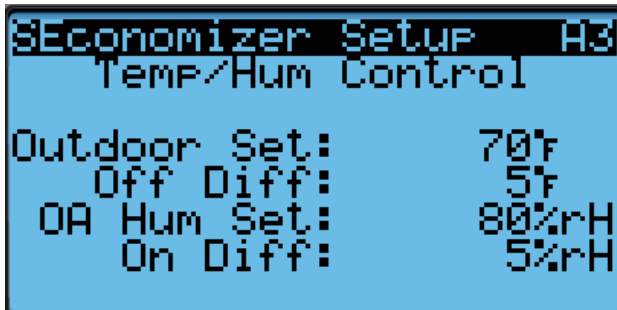

**FIGURE 43**  
Economizer Setup – Enthalpy Control

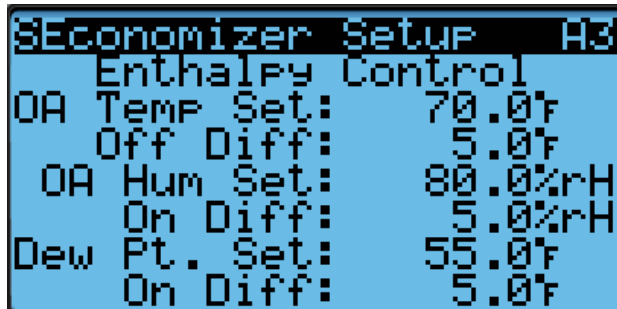

27. Press UP or DOWN keys to adjust the outdoor dew point setpoint for economizer operation to the desired value.
28. Press ENTER key to save the value and scroll to **On Diff**.
29. Press UP or DOWN keys to adjust the dew point differential for which the economizer is re-enabled.
30. Press ENTER key to save the value.
31. Press ESCAPE key several times to return to Main Menu screen.

See Table 6 for default settings for economizer operation.

When the economizer is activated during a free cooling call only, using any of the previously mentioned modes, a 0-10v analog signal will be sent to the economizer actuator. The actuator will then open and close the damper blades to maintain a mixed air temperature of 55°F. When the mixed air temperature increases, the damper will open and when the mixed air temperature decreases, the damper will close.

The economizer may be disabled by the LC if the system determines it needs to enter dehumidification mode. More information about the dehumidification sequence can be found in the latest revision of LC6000 Service Instructions 2100-669. In addition to dehum mode, the economizer may be disabled for 5 minutes (adjustable) if the dust sensor indicates the outdoor air may cause particulate buildup in the air filters. After the time has expired and on a call for cooling, the economizer will open again to sample the air. The wall-mount unit will either return to normal operation or remain locked out for another 5 minutes.

**Economizer Operation – Minimum Position**

The economizer has an option to set minimum position for the economizer. The minimum position will only be active while the blower is operating. To enable minimum position all the time, continuous blower must be activated for the wall unit in the LC6000. See latest version of LC6000 Service Instructions 2100-669 for continuous blower configuration.

**TABLE 6**  
Economizer Default Settings

Mode		Consideration	Economizer Available for Cooling	Economizer Not Available for Cooling	
Temp Only	Temp & Humidity	Enthalpy*	Temperature	When the outdoor air temperature is below 70°F	When the outdoor air temperature is above 75°F
			Humidity	When the outdoor humidity is below 80%	When the outdoor humidity is above 80%
			Dew Point	When the outdoor dew point is below 55°F	When the outdoor dew point is above 60°F

\* In Enthalpy mode, outdoor temperature, humidity and calculated dew point are all considered for economizer operation.

To set the minimum position value:

1. Press MENU key to go to the Main Menu screen.
2. Press UP or DOWN keys and ENTER key to enter USER password 2000.
3. Press UP or DOWN keys to scroll to **System Config**; press ENTER key.
4. Press UP or DOWN keys to scroll to **Economizer Setup A2**.
5. Press ENTER key to scroll to **Min Position** (see Figure 40 on page 28).
6. Press UP or DOWN keys to change to the desired value.

## Miscellaneous Components

### Supply Temperature Sensor

The unit is equipped with a supply air temperature sensor to monitor the leaving air temperature of the unit. The temperature is measured with a 10k ohm NTC thermistor.

The supply air temperature can be verified by:

1. Press MENU key to go to the Main Menu screen.
2. Press UP or DOWN keys and ENTER key to enter TECHNICIAN password 1313.
3. Press UP or DOWN keys to scroll to **I/O Config**; press ENTER key.
4. Press UP or DOWN keys to scroll to **Analog Inputs**; press ENTER key.
5. Press UP or DOWN keys to scroll to **Analog Ins 2/19**.
6. Reference the **Value** to see the input of the sensor (see Figure 44).
7. To apply an offset, press ENTER key to scroll to **Offset**.
8. Press UP or DOWN keys to change to the desired value.
9. Press ENTER key to save the value.

**FIGURE 44**  
Supply Air Temperature Sensor

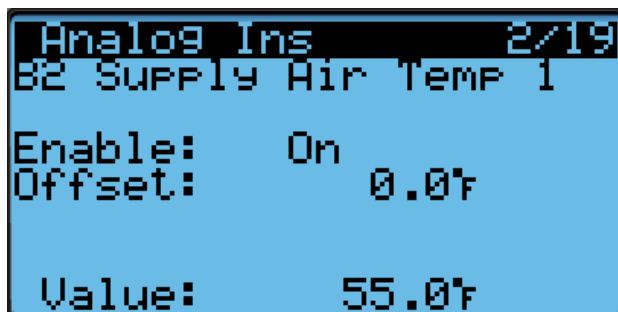

### Supply Temperature Sensor Failure Alarm

When the sensor reads a value that is outside of the acceptable -41.0 to 303.0° range, an alarm will be generated indicating the sensor has failed.

This alarm is fixed and cannot be adjusted.

### Emergency Cooling Mode

If the shelter temperature is above the high temperature alarm setpoint on the LC, the unit will be commanded into emergency cooling mode. In this mode, the unit will operate the economizer regardless of the economizer setup, as long as the outdoor temperature is below the indoor temperature. This will stay active until the LC returns the unit to normal operation.

### Emergency Cooling – Orphan Mode

When the unit is not connected to the LC6000 and operating in orphan mode, the unit still has the capability to operate in emergency cooling mode. By default this feature is not enabled.

To enable emergency cooling in orphan mode:

1. Press MENU key to go to the Main Menu screen.
2. Press UP or DOWN keys and ENTER key to enter TECHNICIAN password 1313.
3. Press UP or DOWN keys to scroll to **Adv System Config**; press ENTER key.
4. Press UP or DOWN keys to scroll to **Emer. Cool B5**.
5. Press ENTER key to scroll to **Use emergency cool in Orphan Mode?** (see Figure 45).
6. Press UP or DOWN keys to change the value.

**FIGURE 45**  
Emergency Cool – Orphan Mode

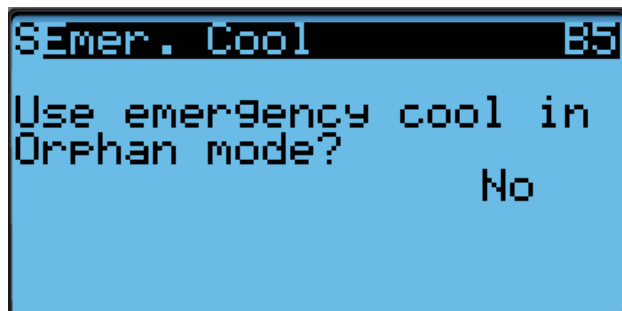

When this feature is used instead of using the zone sensor, an alarm will be triggered by the high return air temperature alarm.

To adjust the return air temperature settings:

1. Press MENU key to go to the Main Menu screen.
2. Press UP or DOWN keys and ENTER key to enter USER password 2000.

3. Press UP or DOWN keys to scroll to **System Config**; press ENTER key.
4. Press UP or DOWN keys to scroll to **Return Air Alarm A5**.
5. Press ENTER key to scroll to **Enable, Lower Limit** or **Upper Limit** (see Figure 46).
6. Press UP or DOWN keys to disable the alarm or change the limit values.

**FIGURE 46**  
Adjusting Return Air Alarm Settings

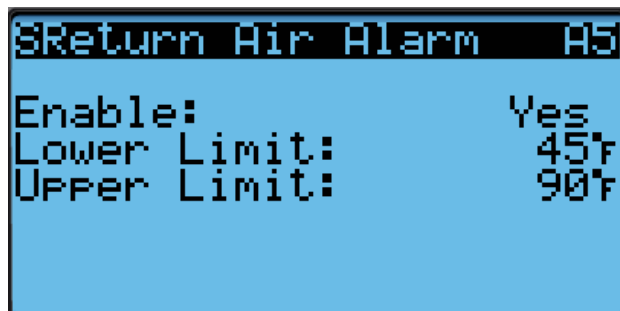

### Emergency Ventilation Mode

If the emergency ventilation input at the LC is active, the system will go into emergency ventilation mode. In emergency ventilation mode, the economizers on the wall units will be commanded to 100%. This mode is only available when connected to the LC.

**NOTE:** All units will receive the emergency ventilation command. Wall units not equipped with economizers will still engage the blower.

### Electric Heat Option

#### Electric Heat Components

##### Electric Heating Element

The unit can be optionally equipped with 9kw or 18kw of heat. The 9kw is a single stage heating element. The 18kw option comes equipped with two 9kw heating elements that operate in two stage. The heating elements are located downstream of the evaporator coils and can be accessed through the upper control panel door.

##### Thermal Overload

The heater assembly has a thermal overload wired in series with the heating element. This device has a cycling limit which opens at 130°F and resets at 80°F. The limit is also equipped with a redundant thermal fuse that will open at 150°F.

##### Electric Heat Operation

The heat strip will be activated on a call for heat. This call can be generated by the LC or the wall-mount unit operating in orphan mode.

### Unit Disable Option

The unit is equipped with an input that can be used to turn off the unit.

The unit disable input can be verified and adjusted by:

1. Press MENU key to go to the Main Menu screen.
2. Press UP or DOWN keys and ENTER key to enter TECHNICIAN password 1313.
3. Press UP or DOWN keys to scroll to **I/O Config**; press ENTER key.
4. Press UP or DOWN keys to scroll to **Digital Inputs**; press ENTER key.
5. Press UP or DOWN keys to scroll to **Digital Ins 1/2**.
6. Reference **Disable** row and **En** column (see Figure 47).
7. Press ENTER key to scroll to **Disable En** value.
8. Press UP or DOWN key to change value.
9. Press ENTER key to scroll to **Dir**.
10. Press UP or DOWN key to change direction (**N/O** or **N/C**), if applicable.
11. Press ESCAPE key several times to return to Main Menu screen.

**FIGURE 47**  
Unit Disable Option

Channel	En	Dir	Val
Disable	No	N/C	Off
CCM1	Yes	N/O	Off
CCM2	Yes	N/O	Off
Airflw 1	Yes	N/O	Off
Airflw 2	No	N/O	Off
Filter 1	Yes	N/O	Off

### Serial/Model Number Configuration

MEGA-TEC wall-mount units configure some settings based on the model number that is input into the unit. The model and serial number are entered at the factory, and should be retained during a software update. However, after a software update, it is best practice to verify that the model and serial number is still present and accurate. If the model and/or serial number is missing or incorrect they will need to be re-entered.

To update serial/model numbers:

1. Press MENU key to go to the Main Menu screen.
2. Press UP or DOWN keys and ENTER key to enter ENGINEER password 9254.
3. Press UP or DOWN keys to scroll to **Adv. Sys. Config**; press ENTER key.

4. Press UP or DOWN keys to scroll to **Unit Setup B1** (see Figure 48).
5. Press ENTER key to advance the cursor to the digit that needs changed in the serial/model number.
6. Press UP or DOWN keys to change value of the digit.
7. Continue Steps 5 and 6 until the serial/model number(s) are correct and reflect the number on the product label.

For more information on the options and settings available for specific model numbers, see the model number breakdown in Figure 49.

**FIGURE 48**  
**Serial/Model Number Configuration**

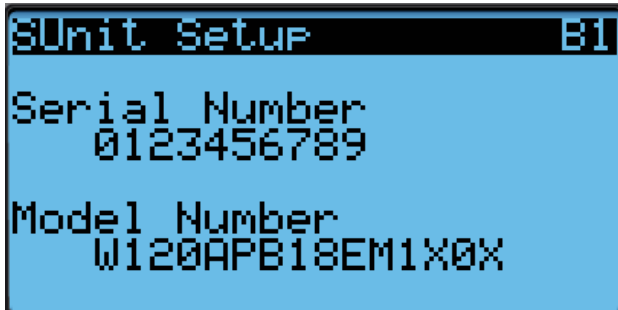



**FIGURE 49**  
**MEGA-TEC Wall-Mount Unit Model Nomenclature**

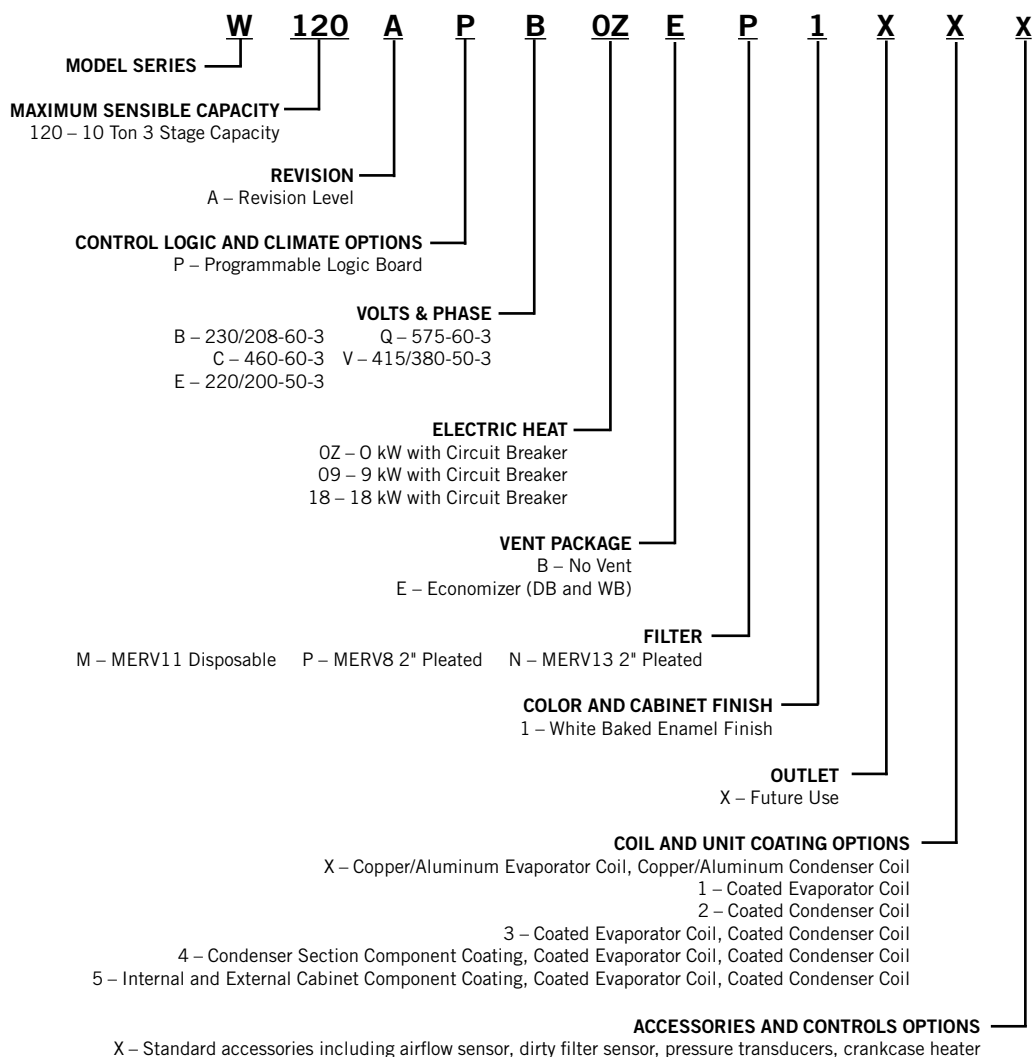

# REFRIGERANT INFORMATION

## NOTICE

These units require R-410A refrigerant and polyol ester oil.

### General

1. Use separate service equipment to avoid cross contamination of oil and refrigerants.
2. Use recovery equipment rated for R-410A refrigerant.
3. Use manifold gauges rated for R-410A (800 PSI/250 PSI low).
4. R-410A is a binary blend of HFC-32 and HFC-125.
5. R-410A is nearly azeotropic—similar to R-22 and R-12. Although nearly azeotropic, charge with liquid refrigerant.
6. R-410A operates at 40-70% higher pressure than R-22, and systems designed for R-22 cannot withstand this higher pressure.
7. R-410A has an ozone depletion potential of zero, but must be reclaimed due to its global warming potential.
8. R-410A compressors use polyol ester oil.
9. Polyol ester oil is hygroscopic; it will rapidly absorb moisture and strongly hold this moisture in the oil.
10. A liquid line dryer must be used—even a deep vacuum will not separate moisture from the oil.
11. Limit atmospheric exposure to 15 minutes.
12. If compressor removal is necessary, always plug compressor immediately after removal. Purge with small amount of nitrogen when inserting plugs.

### Topping Off System Charge

If a leak has occurred in the system, Bard Manufacturing recommends reclaiming, evacuating (see criteria above) and charging to the nameplate charge. If done correctly, topping off the system charge can be done without problems.

With R-410A, there are no significant changes in the refrigerant composition during multiple leaks and recharges. R-410A refrigerant is close to being an azeotropic blend (it behaves like a pure compound or single component refrigerant). The remaining refrigerant charge in the system may be used after leaks have occurred. “Top-off” the charge by utilizing the pressure charts on the inner control panel cover as a guideline.

**REMEMBER:** When adding R-410A refrigerant, it must come out of the charging cylinder/tank as a liquid to avoid any fractionation and to insure optimal system performance. Refer to instructions for the cylinder that is being utilized for proper method of liquid extraction.

### Safety Practices

1. Never mix R-410A with other refrigerants.
2. Use gloves and safety glasses. Polyol ester oils can be irritating to the skin, and liquid refrigerant will freeze the skin.
3. Never use air and R-410A to leak check; the mixture may become flammable.
4. Do not inhale R-410A—the vapor attacks the nervous system, creating dizziness, loss of coordination and slurred speech. Cardiac irregularities, unconsciousness and ultimately death can result from breathing this concentration.
5. Do not burn R-410A. This decomposition produces hazardous vapors. Evacuate the area if exposed.
6. Use only cylinders rated DOT4BA/4BW 400.
7. Never fill cylinders over 80% of total capacity.
8. Store cylinders in a cool area, out of direct sunlight.
9. Never heat cylinders above 125°F.
10. Never trap liquid R-410A in manifold sets, gauge lines or cylinders. R-410A expands significantly at warmer temperatures. Once a cylinder or line is full of liquid, any further rise in temperature will cause it to burst.

### Important Installer Note

For improved start-up performance, wash the indoor coil with a dishwashing detergent.

### R410-A Refrigerant Charge

This wall-mount unit was charged at the factory with the quantity of refrigerant listed on the serial plate. AHRI capacity and efficiency ratings were determined by testing with this refrigerant charge quantity.

Table 7 shows nominal pressures for the units. The use of pressure gauges should not be necessary as the measurements are available through the TEC-EYE hand-held diagnostic too. Since many installation specific situations can affect the pressure readings, this information should only be used by certified technicians as a guide for evaluating proper system performance. They shall not be used to adjust charge. If charge is in doubt, reclaim, evacuate and recharge the wall-mount unit to the serial plate charge.

## Pressure Service Ports

High and low pressure service ports are installed on all wall-mount units so that the system operating pressures can be observed. Pressures are shown in Table 8.

This unit employs high-flow Coremax valves instead of the typical Schrader type valves.

**WARNING! Do NOT use a Schrader valve core removal tool with these valves. Use of such a tool could result in eye injuries or refrigerant burns!**

To change a Coremax valve without first removing the refrigerant, a special tool is required which can be obtained at [www.fastestinc.com/en/SCCA07H](http://www.fastestinc.com/en/SCCA07H). See the replacement parts manual for replacement core part numbers.

**TABLE 7**  
**Cooling Pressures**

Cooling Air Temperature Entering Outdoor Coil °F													
Model	Return Air Temp	Pressure	75	80	85	90	95	100	105	110	115	120	125
W120AP Stage 3	75° DB	Low Side	125	126	127	128	129	130	132	133	135	137	137
	62° WB	High Side	312	334	357	379	403	427	451	476	501	527	553
	80° DB	Low Side	134	135	136	137	138	139	141	142	144	146	147
	67° WB	High Side	320	343	366	389	413	438	463	488	514	540	567
	85° DB	Low Side	139	140	141	142	143	144	146	147	149	151	152
	72° WB	High Side	331	355	379	403	427	453	479	505	532	559	587
W120AP Stage 2	75° DB	Low Side	136	137	137	138	140	141	142	144	145	147	148
	62° WB	High Side	289	308	330	352	374	398	423	448	474	501	528
	80° DB	Low Side	145	146	147	148	150	151	152	154	155	157	158
	67° WB	High Side	296	316	338	361	384	408	434	459	486	514	542
	85° DB	Low Side	150	151	152	153	155	156	157	159	160	162	164
	72° WB	High Side	306	327	350	374	397	422	449	475	503	532	561
W120AP Stage 1	75° DB	Low Side	125	127	128	130	131	133	135	136	137	139	141
	62° WB	High Side	311	332	355	377	402	427	452	479	506	534	563
	80° DB	Low Side	134	136	137	139	140	142	144	145	147	149	151
	67° WB	High Side	319	341	364	387	412	438	464	491	519	548	577
	85° DB	Low Side	139	141	142	144	145	147	149	150	152	154	156
	72° WB	High Side	330	353	377	401	426	453	480	508	537	567	597

Low side pressure ± 4 PSIG  
High side pressure ± 10 PSIG

Tables are based upon rated CFM (airflow) across the evaporator coil. If there is any doubt as to correct operating charge being in the system, the charge should be removed and system evacuated and recharged to serial plate charge weight.

**NOTE:** Pressure table based on high speed condenser fan operation. If condensing pressures appear elevated check condenser fan wiring. See "Condenser Fan Operation" on page 22.

# MAINTENANCE

---

## Standard Maintenance Procedures

### **WARNING**

**Electrical shock hazard.**

**Disconnect all power supplies before servicing.**

**Failure to do so could result in electric shock or death.**

### **CAUTION**

**Cut hazard.**

**Wear gloves to avoid contact with sharp edges.**

**Failure to do so could result in personal injury.**

1. Disable system from LC6000 controller (see latest revision of LC6000 Service Instructions 2100-669).
2. Turn off AC breakers at wall-mount units.
3. Check inlet sides of condenser and evaporator coils for obstructions/debris—clean if necessary using a quality manufactured coil cleaning product specific for the evaporator or condenser coil.
  - Condenser coil: For inlet-side cleaning, remove condenser grilles. For outlet-side cleaning, remove condenser fan panel. Unbolt fan from mounting brackets and slide fan outward until lower locking arm drops into position. Pivot fan by lifting fan locking arm. Follow the coil cleaner manufacturer's directions for necessary safety gear and precautions, as well as for application and use. More than one application may be necessary. Rinse thoroughly.
4. Manually spin fan and blower motors to ensure they turn freely. All motors are permanently lubricated, so no oil is necessary.
5. Inspect free cooling damper actuator and linkage.
6. Install new air filters.
7. Inspect the control panel of the system.
  - Look for insect or rodent activity and remove any nesting materials.
  - Manually push contactor closed, observe for movement—contactor points should have minimal discoloration, no spalling or other signs of arcing. Replace if doubtful.
  - Check field and factory wiring for tightness and look for signs of overheating (discoloration of terminals or wire insulation).
8. Ensure that supply and return registers are not obstructed, and more importantly, are not recycling the air to one another. Adjust supply louvers if necessary to direct discharge air away from any direct route to the return grille.
9. Re-assemble wall-mount unit, remembering to fasten fan to mounting brackets. Turn breakers back on.
10. Enable system to LC6000 controller (see latest revision of LC6000 Service Instructions 2100-669).
11. Repeat steps for additional wall-mount units.

## 8301-089 Outdoor Temperature/Humidity Sensor

FIGURE 50  
8301-089 Sensor DIP Switches and Terminal Block

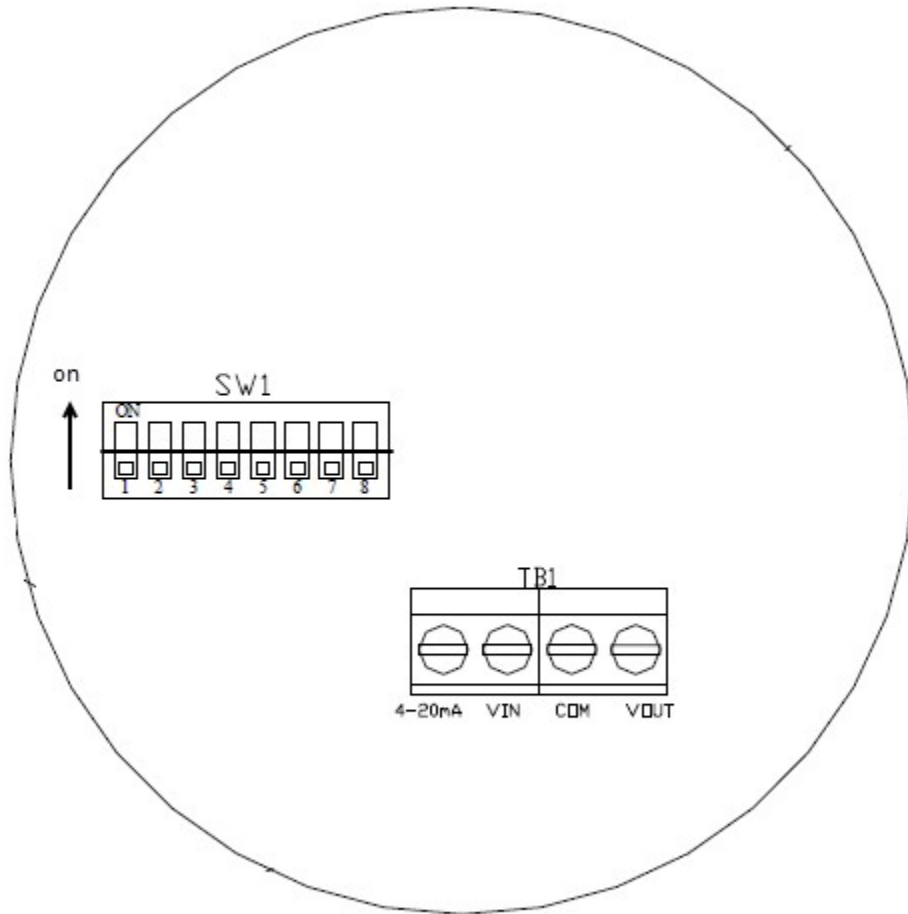

**TABLE 8**  
**8301-089 Sensor: Temperature/Resistance**

Temperature		Resistance	Temperature		Resistance	Temperature		Resistance	Temperature		Resistance
F	C	Ω	F	C	Ω	F	C	Ω	F	C	Ω
-25	-31.7	148,452.94	13	-10.6	48,892.46	51	10.6	18,337.51	89	31.7	7679.76
-24	-31.1	143,910.37	14	-10.0	47,571.97	52	11.1	17,898.38	90	32.2	7515.86
-23	-30.6	139,521.46	15	-9.4	46,291.29	53	11.7	17,471.09	91	32.8	7355.94
-22	-30.0	135,280.55	16	-8.9	45,049.09	54	12.2	17,055.30	92	33.3	7199.88
-21	-29.4	131,182.22	17	-8.3	43,844.12	55	12.8	16,650.65	93	33.9	7047.59
-20	-28.9	127,221.25	18	-7.8	42,675.14	56	13.3	16,256.82	94	34.4	6898.95
-19	-28.3	123,392.63	19	-7.2	41,540.99	57	13.9	15,873.48	95	35.0	6753.88
-18	-27.8	119,691.54	20	-6.7	40,440.51	58	14.4	15,500.34	96	35.6	6612.28
-17	-27.2	116,113.37	21	-6.1	39,372.62	59	15.0	15,137.09	97	36.1	6474.05
-16	-26.7	112,653.66	22	-5.6	38,336.26	60	15.6	14,783.44	98	36.7	6339.11
-15	-26.1	109,308.15	23	-5.0	37,330.40	61	16.1	14,439.11	99	37.2	6207.37
-14	-25.6	106,072.72	24	-4.4	36,354.06	62	16.7	14,103.83	100	37.8	6078.74
-13	-25.0	102,943.44	25	-3.9	35,406.29	63	17.2	13,777.34	101	38.3	5953.15
-12	-24.4	99,916.50	26	-3.3	34,486.17	64	17.8	13,459.38	102	38.9	5830.51
-11	-23.9	96,988.26	27	-2.8	33,592.81	65	18.3	13,149.70	103	39.4	5710.75
-10	-23.3	94,155.21	28	-2.2	32,725.36	66	18.9	12,848.07	104	40.0	5593.78
-9	-22.8	91,413.97	29	-1.7	31,883.00	67	19.4	12,554.26	105	40.6	5479.55
-8	-22.2	88,761.30	30	-1.1	31,064.92	68	20.0	12,268.04	106	41.1	5367.98
-7	-21.7	86,194.07	31	-0.6	30,270.36	69	20.6	11,989.19	107	41.7	5258.99
-6	-21.1	83,709.29	32	0.0	29,498.58	70	21.1	11,717.51	108	42.2	5152.53
-5	-20.6	81,304.06	33	0.6	28,748.85	71	21.7	11,452.79	109	42.8	5048.52
-4	-20.0	78,975.60	34	1.1	28,020.48	72	22.2	11,194.83	110	43.3	4946.91
-3	-19.4	76,721.24	35	1.7	27,312.81	73	22.8	10,943.45	111	43.9	4847.63
-2	-18.9	74,538.41	36	2.2	26,625.18	74	23.3	10,698.45	112	44.4	4750.62
-1	-18.3	72,424.61	37	2.8	25,956.98	75	23.9	10,459.65	113	45.0	4655.83
0	-17.8	70,377.48	38	3.3	25,307.60	76	24.4	10,226.90	114	45.6	4563.20
1	-17.2	68,394.70	39	3.9	24,676.45	77	25.0	10,000.00	115	46.1	4472.67
2	-16.7	66,474.07	40	4.4	24,062.97	78	25.6	9778.81	116	46.7	4384.19
3	-16.1	64,613.46	41	5.0	23,466.62	79	26.1	9563.15	117	47.2	4297.71
4	-15.6	62,810.82	42	5.6	22,886.87	80	26.7	9352.89	118	47.8	4213.18
5	-15.0	61,064.17	43	6.1	22,323.22	81	27.2	9147.86	119	48.3	4130.55
6	-14.4	59,371.62	44	6.7	21,775.16	82	27.8	8947.93	120	48.9	4049.77
7	-13.9	57,731.32	45	7.2	21,242.23	83	28.3	8752.95	121	49.4	3970.79
8	-13.3	56,141.52	46	7.8	20,723.96	84	28.9	8562.79	122	50.0	3893.58
9	-12.8	54,600.50	47	8.3	20,219.91	85	29.4	8377.31	123	50.6	3818.08
10	-12.2	53,106.64	48	8.9	19,729.65	86	30.0	8196.39	124	51.1	3744.26
11	-11.7	51,658.35	49	9.4	19,252.76	87	30.6	8019.91	125	51.7	3672.07
12	-11.1	50,254.11	50	10.0	18,788.84	88	31.1	7847.74			

**TABLE 9**  
**8301-089 Sensor: Humidity/mA**

RH%	mA Output	RH%	mA Output	RH%	mA Output
0	4.000 mA	34	9.440 mA	68	14.880 mA
1	4.160 mA	35	9.600 mA	69	15.040 mA
2	4.320 mA	36	9.760 mA	70	15.200 mA
3	4.480 mA	37	9.920 mA	71	15.360 mA
4	4.640 mA	38	10.080 mA	72	15.520 mA
5	4.800 mA	39	10.240 mA	73	15.680 mA
6	4.960 mA	40	10.400 mA	74	15.840 mA
7	5.120 mA	41	10.560 mA	75	16.000 mA
8	5.280 mA	42	10.720 mA	76	16.160 mA
9	5.440 mA	43	10.880 mA	77	16.320 mA
10	5.600 mA	44	11.040 mA	78	16.480 mA
11	5.760 mA	45	11.200 mA	79	16.640 mA
12	5.920 mA	46	11.360 mA	80	16.800 mA
13	6.080 mA	47	11.520 mA	81	16.960 mA
14	6.240 mA	48	11.680 mA	82	17.120 mA
15	6.400 mA	49	11.840 mA	83	17.280 mA
16	6.560 mA	50	12.000 mA	84	17.440 mA
17	6.720 mA	51	12.160 mA	85	17.600 mA
18	6.880 mA	52	12.320 mA	86	17.760 mA
19	7.040 mA	53	12.480 mA	87	17.920 mA
20	7.200 mA	54	12.640 mA	88	18.080 mA
21	7.360 mA	55	12.800 mA	89	18.240 mA
22	7.520 mA	56	12.960 mA	90	18.400 mA
23	7.680 mA	57	13.120 mA	91	18.560 mA
24	7.840 mA	58	13.280 mA	92	18.720 mA
25	8.000 mA	59	13.440 mA	93	18.880 mA
26	8.160 mA	60	13.600 mA	94	19.040 mA
27	8.320 mA	61	13.760 mA	95	19.200 mA
28	8.480 mA	62	13.920 mA	96	19.360 mA
29	8.640 mA	63	14.080 mA	97	19.520 mA
30	8.800 mA	64	14.240 mA	98	19.680 mA
31	8.960 mA	65	14.400 mA	99	19.840 mA
32	9.120 mA	66	14.560 mA	100	20.000 mA
33	9.280 mA	67	14.720 mA		

**8620-296 Supply Air Sensor/Return Air Sensor/Mixed Air Sensor/Suction Sensor/  
Liquid Sensor**

**TABLE 10  
8620-296 Sensor: Temperature/Resistance Curve J**

Temperature °F	Resistance Ω	Temperature °F	Resistance Ω	Temperature °F	Resistance Ω	Temperature °F	Resistance Ω
-25.0	196871	13.0	56985	53.0	19374	89.0	7507
-24.0	190099	14.0	55284	52.0	18867	90.0	7334
-23.0	183585	15.0	53640	53.0	18375	91.0	7165
-22.0	177318	16.0	52051	54.0	17989	92.0	7000
-21.0	171289	17.0	50514	55.0	17434	93.0	6840
-20.0	165487	18.0	49028	56.0	16984	94.0	6683
-19.0	159904	19.0	47590	57.0	16547	95.0	6531
-18.0	154529	20.0	46200	58.0	16122	96.0	6383
-17.0	149355	21.0	44855	59.0	15710	97.0	6239
-16.0	144374	22.0	43554	60.0	15310	98.0	6098
-15.0	139576	23.0	42295	61.0	14921	99.0	5961
-14.0	134956	24.0	41077	62.0	14544	100.0	5827
-13.0	130506	25.0	39898	63.0	14177	101.0	5697
-12.0	126219	26.0	38757	64.0	13820	102.0	5570
-11.0	122089	27.0	37652	65.0	13474	103.0	5446
-10.0	118108	28.0	36583	66.0	13137	104.0	5326
-9.0	114272	29.0	35548	67.0	12810	105.0	5208
-8.0	110575	30.0	34545	68.0	12492	106.0	5094
-7.0	107010	31.0	33574	69.0	12183	107.0	4982
-6.0	103574	32.0	32634	70.0	11883	108.0	4873
-5.0	100260	33.0	31723	71.0	11591	109.0	4767
-4.0	97064	34.0	30840	72.0	11307	110.0	4663
-3.0	93981	35.0	29986	73.0	11031	111.0	4562
-2.0	91008	36.0	29157	74.0	10762	112.0	4464
-1.0	88139	37.0	28355	75.0	10501	113.0	4367
0.0	85371	38.0	27577	76.0	10247	114.0	4274
1.0	82699	39.0	26823	77.0	10000	115.0	4182
2.0	80121	40.0	26092	78.0	9760	116.0	4093
3.0	77632	41.0	25383	79.0	9526	117.0	4006
4.0	75230	42.0	24696	80.0	9299	118.0	3921
5.0	72910	43.0	24030	81.0	9077	119.0	3838
6.0	70670	44.0	23384	82.0	8862	120.0	3757
7.0	68507	45.0	22758	83.0	8653	121.0	3678
8.0	66418	46.0	22150	84.0	8449	122.0	3601
9.0	64399	47.0	21561	85.0	8250	123.0	3526
10.0	62449	48.0	20989	86.0	8057	124.0	3452
11.0	60565	49.0	20435	87.0	7869		
12.0	58745	50.0	19896	88.0	7686		



## 8301-057 Blower Status Switch/Dirty Filter Switch

FIGURE 51  
8301-057 Air Differential Switch Terminals

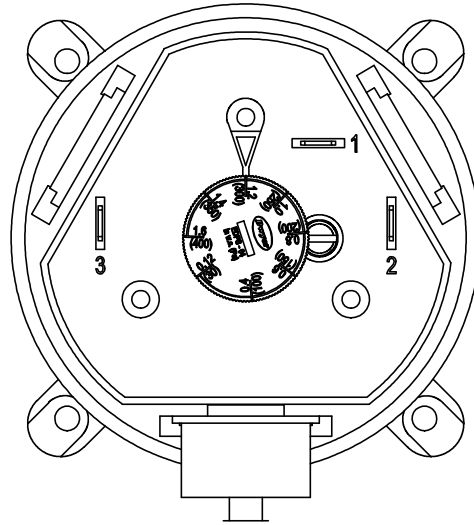

### Terminals

- 1 – Normally Closed
- 2 – Normally Open
- 3 – Common

**NOTE:** Contact position is in resting state.

## Alarm Index

**TABLE 11**  
**MEGA-TEC Alarm Index**

Index	Description
0	Error in the number of retain memory writings
1	Error in retain memory writings
2	Circuit 1 Return Air Temperature Sensor Alarm
3	Circuit 1 High Return Air Temperature Alarm
4	Circuit 2 Return Air Temperature Sensor Alarm
5	Circuit 2 High Return Air Temperature Alarm
6	Circuit 1 Mixed Air Temperature Sensor Alarm
7	Circuit 1 Mixed Air High Temperature
8	Circuit 1 Mixed Air Low Temperature
9	Circuit 2 Mixed Air Temperature Sensor Alarm
10	Circuit 2 Mixed Air High Temperature
11	Circuit 2 Mixed Air Low Temperature
12	Circuit 1 Supply Air Temperature Sensor Alarm
13	Circuit 1 High Supply Air Temperature Alarm
14	Circuit 1 Low Supply Air Temperature Alarm
15	Circuit 2 Supply Air Temperature Sensor Alarm
16	Circuit 2 High Supply Air Temperature Alarm
17	Circuit 2 Low Supply Air Temperature Alarm
18	Outdoor Air Temperature Sensor Alarm
19	Outdoor Air Humidity Sensor Alarm
20	Circuit 1 Dust Sensor Alarm
21	Circuit 1 Dust Sensor High Dust Detection Alarm
22	Circuit 2 Dust Sensor Alarm
23	Circuit 2 Dust Sensor High Dust Detection Alarm
24	Circuit 1 Liquid Line Temp Sensor Alarm
25	Circuit 2 Liquid Line Temp Sensor Alarm
26	Circuit 1 Liquid Line Pressure Sensor Alarm
27	Circuit 2 Liquid Line Pressure Sensor Alarm
28	Circuit 1 Discharge Temp Sensor Alarm
29	Circuit 2 Discharge Temp Sensor Alarm
30	Circuit 1 Discharge Pressure Sensor Alarm
31	Circuit 2 Discharge Pressure Sensor Alarm
32	Circuit 1 Suction Temperature Sensor Alarm
33	Circuit 2 Suction Temperature Sensor Alarm
34	Circuit 1 Suction Pressure Sensor Alarm
35	Circuit 2 Suction Pressure Sensor Alarm
36	Circuit 1 Low Pressure
37	Circuit 2 Low Pressure
38	Circuit 1 High Pressure
39	Circuit 2 High Pressure
40	Circuit 1 Damper Failed to Open
41	Circuit 1 Damper Failed to Close

Index	Description
42	Circuit 2 Damper Failed to Close
43	Circuit 2 Damper Failed to Open
44	Circuit 3 Damper Failed to Open
45	Circuit 3 Damper Failed to Close
46	Circuit 4 Damper Failed to Open
47	Circuit 4 Damper Failed to Close
48	Circuit 1 Freeze Temperature Sensor Alarm
49	Circuit 2 Freeze Temperature Sensor Alarm
50	Circuit 1 Freeze Condition
51	Circuit 2 Freeze Condition
52	Circuit 1 Blower Fail Alarm
53	Circuit 2 Blower Fail Alarm
54	Dirty Filter 1 Alarm
55	Dirty Filter 2 Alarm
56	Dirty Filter 3 Alarm
57	Dirty Filter 4 Alarm
58	Circuit 1 Dirty Condenser Coil Alarm
59	Circuit 2 Dirty Condenser Coil Alarm
60	Emergency Ventilation Mode Active
61	Emergency Cooling Mode Active
62	Extreme High Return Temp Alarm (Heat Cutout)
63	Unit Disable/Smoke Detector Alarm
64	Circuit 1 Power Loss Detected
65	Circuit 2 Power Loss Detected
66	Circuit 1 Low SuperHeat
67	Circuit 1 Low Evaporation Pressure
68	Circuit 1 High Evaporation Pressure
69	Circuit 1 High Condenser Temperature
70	Circuit 1 Low Suction Pressure
71	Circuit 1 EEV Motor Error
72	Circuit 1 Self Tuning Error
73	Circuit 1 Emergency Close
74	Circuit 1 High Delta Temperature
75	Circuit 1 High Delta Pressure
76	Circuit 1 Range Error
77	Circuit 1 Service Position Percent
78	Circuit 1 Valve ID
79	Circuit 2 Low SuperHeat
80	Circuit 2 Low Evaporation Pressure
81	Circuit 2 High Evaporation Pressure
82	Circuit 2 High Condenser Temperature
83	Circuit 2 Low Suction Pressure

<b>Index</b>	<b>Description</b>
84	Circuit 2 EEV Motor Error
85	Circuit 2 Self Tuning Error
86	Circuit 2 Emergency Close
87	Circuit 2 High Delta Temperature
88	Circuit 2 High Delta Pressure
89	Circuit 2 Range Error
90	Circuit 2 Service Position Percent
91	Circuit 2 Valve ID
92	Th-Tune Device Offline
93	Th-Tune Temperature Probe Alarm
94	Th-Tune Humidity Probe Alarm
95	Th-Tune Clock Board Alarm
96	c.pCOe Offline
97	Offline EBM Blower 1
98	
99	Offline EBM Blower 2
100	
101	Offline EBM Fan 1
102	
103	Offline EBM Fan 2
104	
105	Circuit 1 Low Return Air Temperature Alarm
106	Circuit 2 Low Return Air Temperature Alarm
107	Panel Switch

## Blower Speeds

**TABLE 12**  
**Blower Speeds**

<b>Mode</b>	<b>Nominal</b>	<b>High Sensible</b>	<b>Enhanced Latent</b>
Free Cooling	57	N/A	N/A
Cooling Stage 1	42	48.5	32.6
Cooling Stage 2	57	63	43.8
Cooling Stage 3	57	63	43.8
Heating Stage 1	57	N/A	N/A
Heating Stage 2	57	N/A	N/A
Emergency Vent	100	N/A	N/A
Freeze Alarm	80	N/A	N/A