INSTALLATION INSTRUCTIONS

VIC1500-24, -48 Inverters

Description

The VIC1500 inverter is installed at sites where a generator may not be present and the units must ventilate the shelter for cooling during a power loss event. The wall-mount unit will detect when main AC power is lost and automatically switch to inverter power, utilizing the shelter battery bank. The inverter will convert either -24VDC (on VIC1500-24 models) or -48VDC (on VIC1500-48 models) to 230VAC. When main AC power is lost at the wall unit, it will energize the power loss relay allowing only the blower and economizer to run—no mechanical cooling permitted.

The shelter controller is powered directly from the shelter DC power supply. A relay output from the inverter can communicate to the supervisory controller or NOC system if an inverter fault occurs. The units will continue to run in economizer-only operation until power has been restored or the battery power has been depleted.

The VIC1500 models contain an inverter, a circuit breaker for DC voltage and two circuit breakers for the wall-mount units (one per unit).

HR36 and HR58 units using the LV1000 controller have remote notification feature.

WARNING

Electric shock hazard.

Disconnect VAC and VDC power supplies before servicing.

Failure to do so could result in electric shock or death.

Installation

List of Materials and Tools Needed for Installation

Additional hardware and miscellaneous supplies are needed for installation. These items are field supplied and must be sourced before installation. This list also includes tools needed for installation.

- Personal protective equipment/safety devices/anti-static wrist straps
- Miscellaneous hand and power tools and jobsite or shop materials
- Electrical supplies:
 - Minimum 14 gauge wire (for connecting to wall-mount units)
 - **HR units only** – Minimum 18 gauge wire (for connecting to LV1000 controller)
 - 6 gauge wire (for DC volt connection)
 - Miscellaneous electrical supplies including rigid/flexible conduit and fittings, wire connectors and supports



Climate Control Solutions

Bard Manufacturing Company, Inc.
Bryan, Ohio 43506
www.bardhvac.com

Manual: 2100-687B
Supersedes: 2100-687A
Date: 6-3-22

Refer to the National Electrical Code (NEC) for complete current carrying capacity data on the various insulation grades of wiring material. All wiring must conform to NEC and all local codes.

IMPORTANT: When working with circuit board components, Bard recommends the use of an anti-static wrist strap to prevent static electricity shorts to electronic controls.

Mounting the VIC1500 Inverter

The VIC1500 **MUST** be mounted near the 24VDC or 48VDC power supply (depending on model) to keep the DC cable short (**maximum 6'**). The dimensions of the VIC1500 are 30" wide x 13" tall x 5" deep and it weighs approximately 30 lbs. Four mounting holes are provided for mounting to the wall and knockouts for conduit connection are provided in the sides of the VIC1500. Secure the controller in its intended location

with fasteners sufficient for the application. **Conduit is recommended for all wiring.**

The VIC1500 must be installed horizontally.

The VIC1500 is not weatherproof and is intended for use inside weathertight structures only.

VIC1500 Wiring

See Figures 1A or 1B for a system overview of VIC1500, power supply, wall mount units and LV1000 supervisory controller (HR units only).

Connecting to Power Supply

VIC1500-24 Inverter: The VIC1500-24 is powered by -24VDC. Use 6 gauge cable to connect the VIC1500-24 to the appropriate -24VDC power supply. **These connections are polarity sensitive.** Connect the power source to the 30 amp circuit breaker in the VIC1500-24 labeled "- 24DC volts +" (see Figure 2).

FIGURE 1A
System Overview: HR Units with LV1000

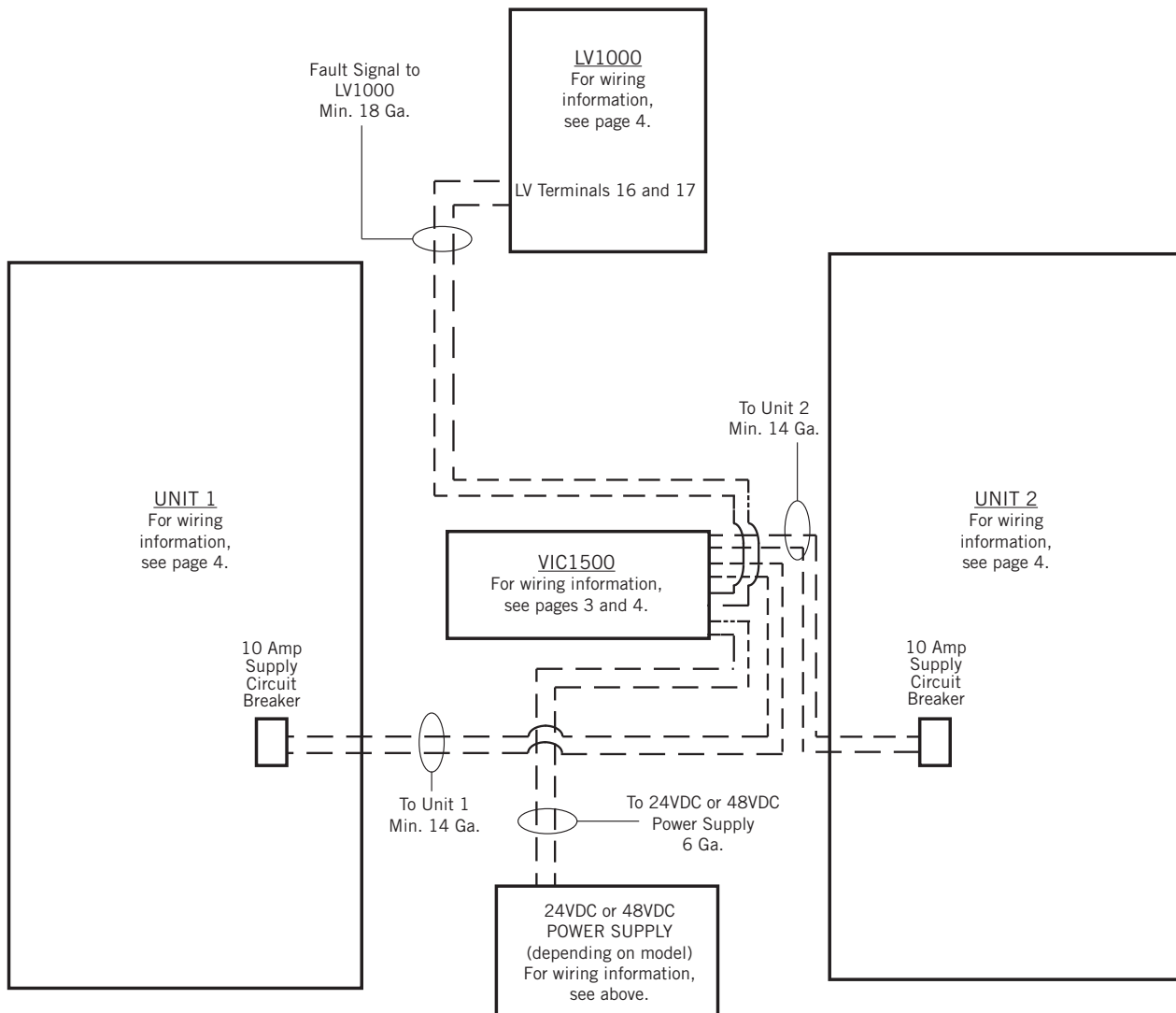
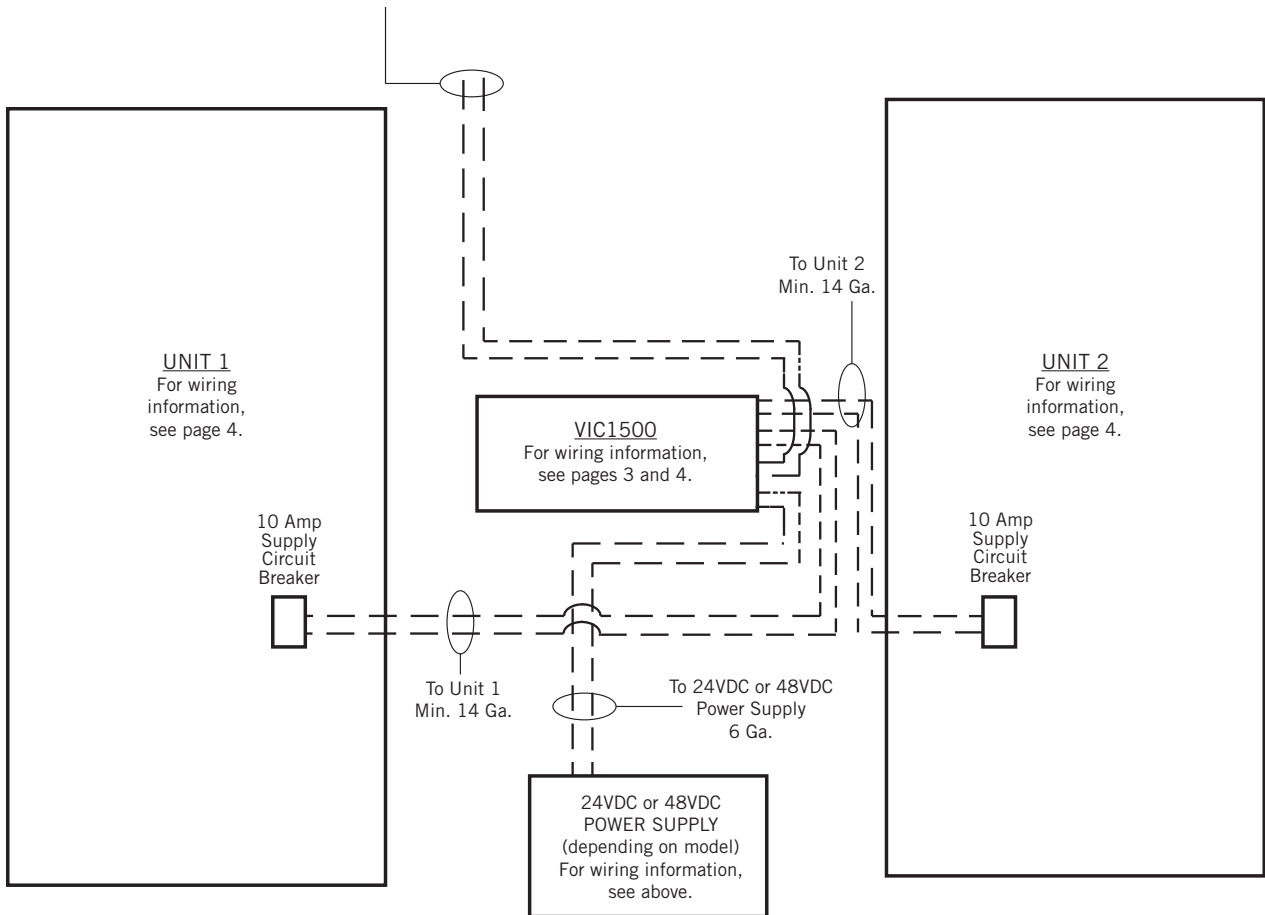

FIGURE 1B
System Overview: WR, WAD141 Units

OPTIONAL: Fault Signal to NOC Connection
 (Normally Closed Dry Contacts) Min. 18 Ga.



VIC1500-48 Inverter: The VIC1500-48 is powered by -48VDC. Use 6 gauge cable to connect the VIC1500-48 to the appropriate -48VDC power supply. **These connections are polarity sensitive.** Connect the power source to the 20 amp circuit breaker in the VIC1500 labeled “- 48DC volts +” (see Figure 2).

IMPORTANT: Verify polarity as shown in Figure 8A (page 6) and Figure 8B (page 7). **Incorrect (reversed) polarity connection can blow the internal (non-replaceable) fuse and damage the unit.**

A reliable earth ground must be connected in addition to any grounding from conduit. Grounding posts and grounding lugs are included with the VIC1500 for this purpose. Attach the earth ground to the side of the VIC1500 using the posts and grounding lugs. **Failure to ground the VIC1500 properly could result in damage to the equipment or personal injury.**

FIGURE 2
VIC1500 Connections Points: Power Supply

VIC1500-24: -24VDC

VIC1500-48: -48VDC



Connecting to Wall-Mount Units

Use minimum 14 gauge cable to connect the VIC1500 to the wall-mount units. Utilizing a knockout on the VIC1500, run two wires from the VIC1500 10 amp circuit breaker labeled UNIT 1 to the 10 amp supply circuit breaker on wall-mount unit 1 and two wires from the VIC1500 10 amp circuit breaker labeled UNIT 2 to the 10 amp supply circuit breaker on wall-mount unit 2 (see Figure 3). The connections are not polarity sensitive. **The system is limited to two units total.**

**FIGURE 3
VIC1500 Connection Points: Wall-Mount Units**



Connecting to LV1000 Controller (HR Units Only)

Connect terminals 16 and 17 on the LV1000 controller terminal block to the VIC1500 fault terminals (dry contacts) with minimum 18 gauge wire. See Figures 4 and 5. Upon fault, the contacts open.

**FIGURE 4
LV1000 Terminal Block (HR Units Only)**

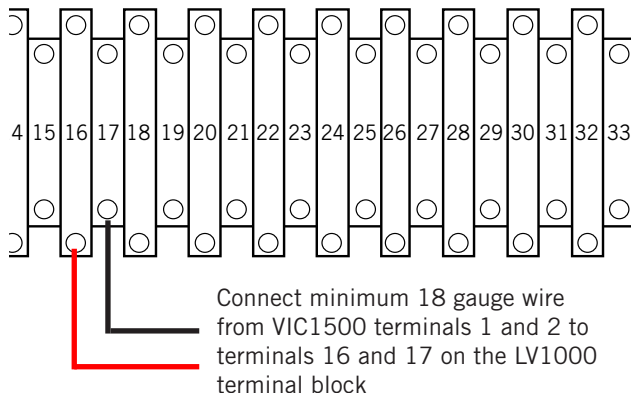

**FIGURE 5
VIC1500 Connection Points:
LV1000 Controller (HR Units Only)**

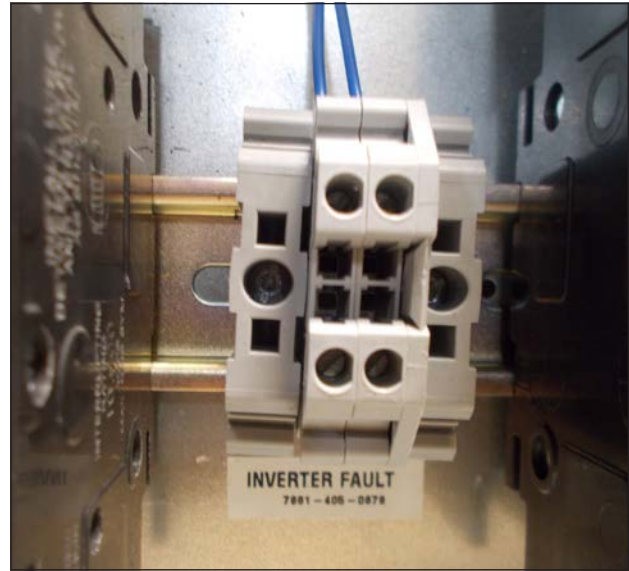

Operation

Make sure all three circuit breakers on the VIC1500 (VIC1500-24: two 10 amp AC circuit breakers and one 30 amp DC circuit breaker/VIC1500-48: two 10 amp AC circuit breakers and one 20 amp DC circuit breaker) are in the OFF position. Adjust S1 and S2 DIP switch position (see Figure 6) as needed depending on supply voltage (see Table 1). DIP switch S3 should be in the ON position and S4 in the OFF position.

**FIGURE 6
VIC1500 DIP Switches and LEDs**

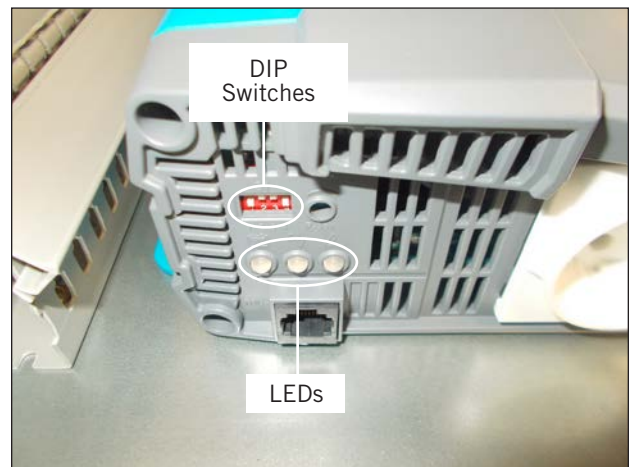

Table 1
Output Voltage Selection

Output Voltage	S1	S2
100V/200V	OFF	OFF
110V/220V	ON	OFF
115V/230V	OFF	ON
120V/240V	ON	ON

Push the rocker switch to the ON position (see Figure 7), push the DC circuit breaker switch (30 amp on VIC1500-24 and 20 amp on VIC1500-48) to the ON position and make sure the three LEDs are all green (see Figure 6). Then push the two 10 amp AC circuit breaker switches (Figure 2) to the ON position.

Green LEDs at this point indicate everything is operating correctly and there are no faults. See Table 2 for a list of fault conditions.

FIGURE 7
VIC1500 Rocker Switch

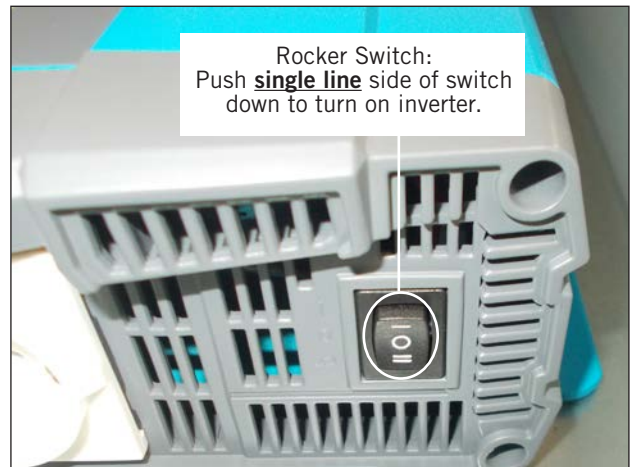

Notification to the LV1000 (HR Units Only)

The VIC1500 will indicate a fault through relay contacts to the shelter controller.

When the input no longer indicates a fault, the contacts automatically close and the alarm relay will return to the closed position.

Table 2
Fault Conditions

LED	Status	Recovery Point
Green	Normal	
Red	Overcurrent Protection/Overload Protection (AC output short circuit and overload)	
Red Slow Blink	Under Voltage Protection (Input DC voltage under spec)	25V @ DC24V system 50V @ DC48V system
Red Fast Blink	Over Voltage Protection (Input DC voltage over spec)	29V @ DC24V system 58V @ DC48V system
Orange	Device startup process abnormal	
Orange Slow Blink	Over Temperature Protection (Heat sink temp. over 80°C)	< 60°C (heat sink temperature)
Orange Fast Blink	Under Temperature Protection (Heat sink temp. under -20°C)	> 0°C

FIGURE 8A
VIC1500 Polarity Verification

VIC-1500-24 Inverter: While checking polarity on -24VDC system (with the breaker to inverter in OFF position), there should be 0VDC from positive input on breaker to ground (as shown here) and -24VDC from the negative input on breaker to ground (as shown in Figure 8B).

VIC-1500-48 Inverter: While checking polarity on -48VDC system (with the breaker to inverter in OFF position), there should be 0VDC from positive input on breaker to ground (as shown here) and -48VDC from the negative input on breaker to ground (as shown in Figure 8B).

Always verify the polarity as shown in this figure and Figure 8B. Incorrect polarity can blow an internal (non-replaceable) fuse and damage unit.

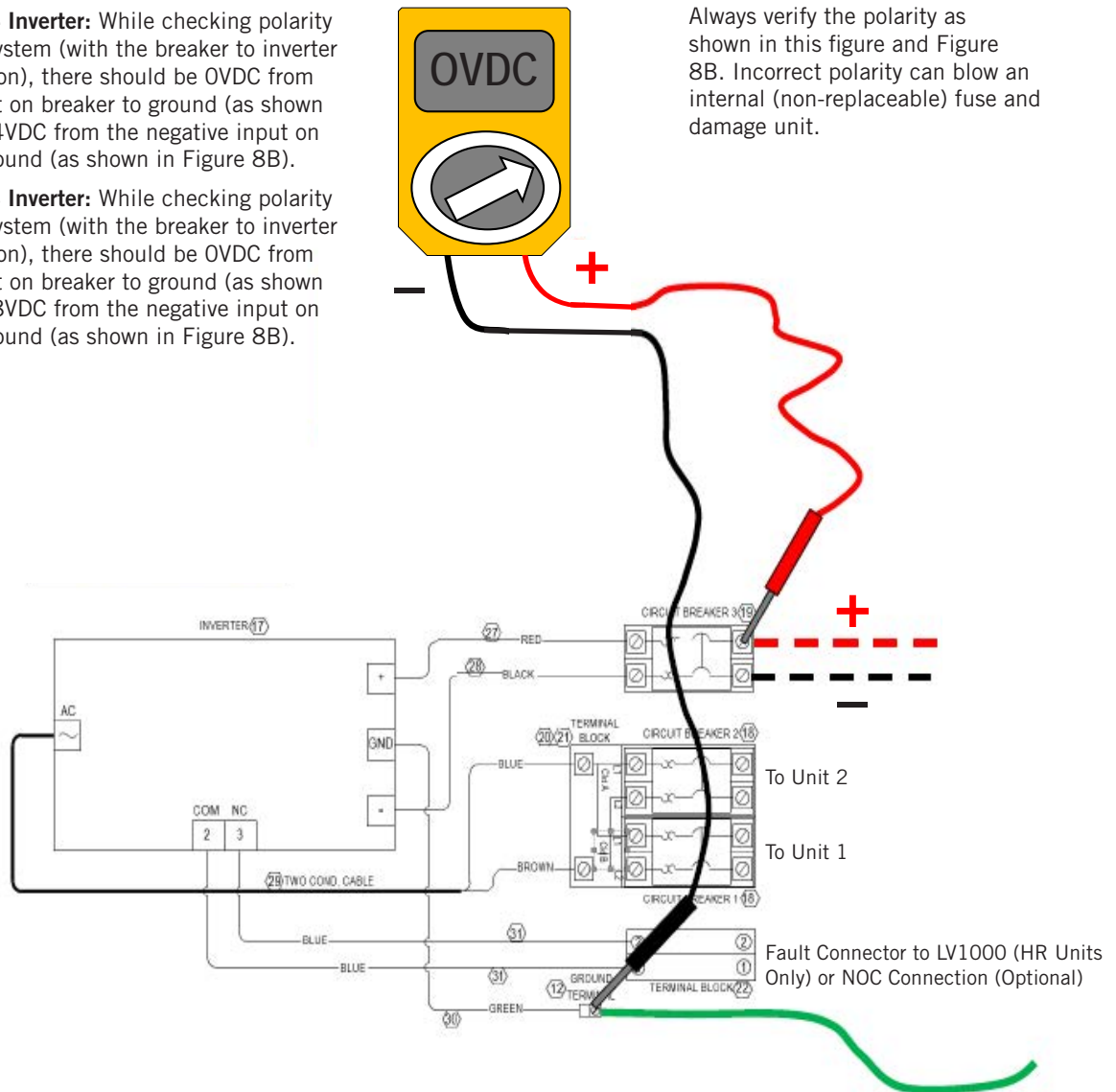

NOTE:

VIC-1500-24 Inverter: When measuring across the two terminals at the breaker (not shown), the acceptable voltage range is from -21VDC to -33VDC.

VIC-1500-48 Inverter: When measuring across the two terminals at the breaker (not shown), the acceptable voltage range is from -42VDC to -66VDC.

FIGURE 8B
VIC1500 Polarity Verification

VIC-1500-24 Inverter: While checking polarity on -24VDC system (with the breaker to inverter in OFF position), there should be 0 VDC from positive input on breaker to ground (as shown in Figure 8A) and -24VDC from negative input on the breaker to ground (as shown here).

VIC-1500-48 Inverter: While checking polarity on -48VDC system (with the breaker to inverter in OFF position), there should be 0 VDC from positive input on breaker to ground (as shown in Figure 8A) and -48VDC from negative input on the breaker to ground (as shown here).

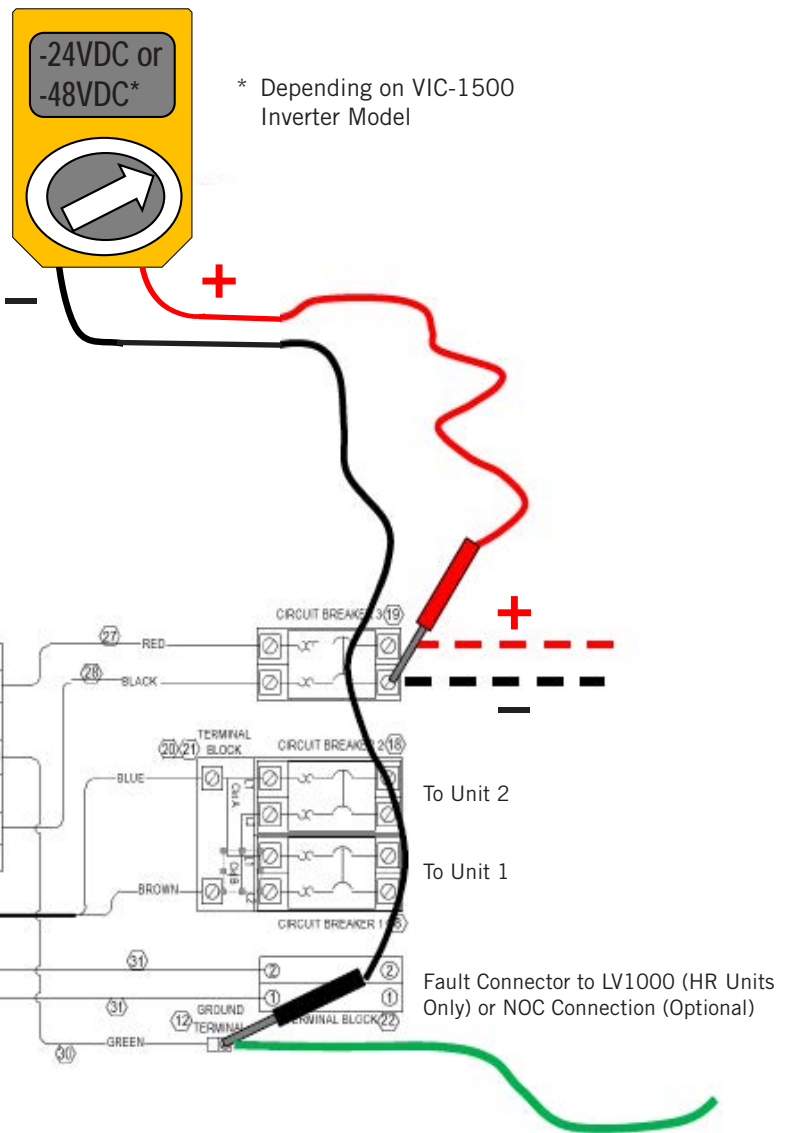

VIC1500 Replacement Parts

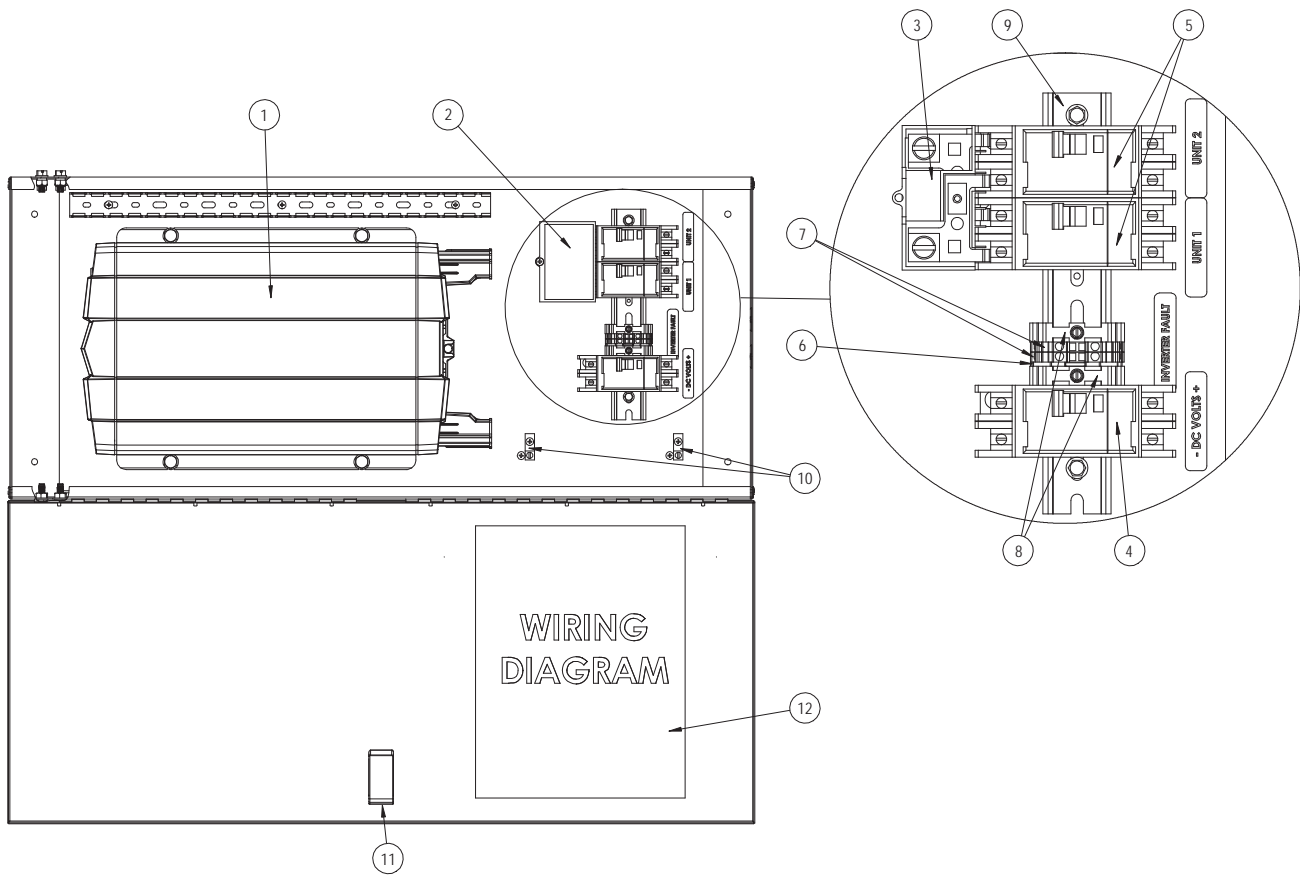

Dwg. No.	Part Number	Description	VIC1500-24	VIC1500-48
1	8301-086	Inverter	X	
1	8301-080	Inverter		X
2	8615-049	Jumper Bar Cover 4 Pole	X	X
3	8615-047	Jumper Bar Base 4 Pole	X	X
4	8615-037	30 Amp Circuit Breaker	X	
4	8615-035	20 Amp Circuit Breaker		X
5	8615-093	10 Amp Circuit Breaker	2	2
6	8611-151	End Cap	X	X
7	8611-150	Terminal Block	2	2
8	8611-144	End Clamp (for Din Rail)	2	2
9	8611-145	Din Rail	X	X
10	8611-006	Ground Terminal	2	2
11	1171-067	Latch	X	X
12	4209-102	Wiring Diagram	X	X