INSTALLATION INSTRUCTIONS

11EER WA Series Wall Mount Air Conditioner

Right Hand Models:

W18AB-A	W24AB-A	W30AB-A	W36AB-A
	W24AB-B	W30AB-B	W36AB-B
	W24AB-C	W30AB-C	W36AB-C
	W24AB-D	W30AB-D	W36AB-D
	W24AB-F	W30AB-F	W36AB-E
			W36AB-F
		W30ABDA	W36ABDA
		W30ABDB	W36ABDB
		W30ABDC	W36ABDC

Left Hand Models:

W18LB-A	W24LB-A	W30LB-A	W36LB-A
	W24LB-B	W30LB-B	W36LB-B
	W24LB-F	W30LB-C	W36LB-C
		W30LB-F	W36LB-F



Bard Manufacturing Company, Inc.
Bryan, Ohio 43506
www.bardhvac.com

Manual: 2100-689I
Supersedes: 2100-689H
Date: 4-15-21

CONTENTS

Getting Other Information and Publications 3

Wall Mount General Information 4

Air Conditioner Wall Mount Model Nomenclature	4
Shipping Damage	4
General	4
Duct Work	5
Filters	5
Fresh Air Intake	5

Installation 6

Basic Installation Design and Application Planning	6
Wall Construction	6
Outdoor Area Inspection	6
Condensate Water Drainage	6
Indoor Ducted and Non-Ducted Applications	6
Indoor Supply Airflow	6
Indoor Return Airflow	6
Ducted Applications	7
Free Blow Applications	7
Thermostat or Indoor Temperature Sensor Placement	7
Unit Installation	7
Materials/Tool List	7
Wall Preparation	8
Wall Mount Installation to Wall Surface	8
Wiring – Main Power	16
Wiring – Low Voltage	16
Low Voltage Connections	16
Unit Shutdown Feature	16
Balanced Climate™ Feature	16
Dehumidification Feature	17
Ventilation Features	17
Low Ambient Control (LAC)	17
Outdoor Temperature Switch and Freeze Protection Thermostat	17
Alarm Relay Feature	17
DDC Controls Feature	17
Dirty Filter Switch Indicator (DFS)	17
Discharge Air Sensor	17
Airflow Switch	17
Compressor Current Sensor	18

Start Up 21

General	21
Topping Off System Charge	21
Safety Practices	21
Important Installer Note	21
High Pressure Switch	21
Three Phase Scroll Compressor Start Up Information	21
Phase Monitor	22
Condenser Fan Operation	22
Service Hints	22

Sequence of Operation	22
Balanced Climate™ Mode	22
Vent Connection Plug	23
Compressor Control Module	23
Features	23
Delay-on-Make Timer	23
Short Cycle/Delay-on-Break	23
Low Pressure Detection	23
High Pressure Detection	23
Test Mode	23
Brownout Protection with Adjustment	23
Pressure Service Ports	24

Service 25

Troubleshooting Nidec SelecTech Series ECM Motors	25
If the Motor is Running	25
If the Motor is Not Running	25
Model SelecTech Communication Diagnostics	26
Fan Blade Setting Dimensions	27
R-410A Refrigerant Charge	27
Removal of Fan Shroud	27
Setting Unit Airflow	32
Blower Speeds	32
Speed Tap 1 – Vent/Blower Only	33
Speed Tap 2 – Balanced Climate	33
Speed Tap 3 – Default LO Cooling & Heating	33
Speed Tap 4 – Optional MED Cooling & Heating	33
Speed Tap 5 – Optional HI Cooling & Heating	33
Dirty Filter Switch	34
Dirty Filter Switch Adjustment	34

FIGURES

Figure 1 Fresh Air Damper	5
Figure 2 Unit Dimensions	10
Figure 3A Mounting Instructions – W18, 24	11
Figure 3B Mounting Instructions – W30, 36	12
Figure 4 Electric Heat Clearance	13
Figure 5 Wall Mounting Instructions	14
Figure 6 Wall Mounting Instructions	14
Figure 7 Common Wall Mounting Installations	15
Figure 8 Programmable Thermostat Connections	19
Figure 9 Thermostat Connections	20
Figure 10 8201-169 Compressor Control Module	24
Figure 11 Motor Connections	25
Figure 12 Motor Connections	26
Figure 13 Fan Blade Setting	27
Figure 14 Speed Taps	32
Figure 15 Speed Taps	33
Figure 16 Dirty Filter Switch Location	34
Figure 17 Adjusting Dirty Filter Switch	35

TABLES

Table 1	Clearance Required for Service Access and Adequate Condenser Airflow.....	9
Table 2	Minimum Clearances Required to Combustible Materials.....	9
Table 3	Additional Low Voltage Connections (if applicable).....	16
Table 4	Low Voltage Connections for DDC Control.....	18
Table 5	Humidity Controls.....	18
Table 6	CO ₂ Controllers.....	18
Table 7	Thermostat Wire Size.....	18
Table 8	Wall Thermostats.....	18
Table 9	Fan Blade Dimensions.....	27
Table 10	Cooling Pressure – Standard Airflow.....	28
Table 11	Cooling Pressure – Balanced Climate Airflow.....	29
Table 12	Electrical Specifications W**AB.....	30
Table 13	Electrical Specifications W**LB.....	31
Table 14	Recommended Airflow.....	32
Table 15	Blower Speeds for Unit Operational Modes.....	33
Table 16	Indoor Blower Performance.....	36
Table 17	Maximum ESP Electric Heat Only.....	37
Table 18	Electric Heat.....	37
Table 19	Vent and Control Options.....	38
Table 20A	Optional Accessories – Right Hand.....	39
Table 20B	Optional Accessories – Left Hand.....	40

GRAPHS

Graph 1	W18*B FAD-NE2, 3 W/O Exhaust Ventilation Delivery.....	41
Graph 2	W24*B FAD-NE2, 3 W/O Exhaust Ventilation Delivery.....	41
Graph 3	W30*B FAD-NE2, 3 W/O Exhaust Ventilation Delivery.....	42
Graph 4	W36*B FAD-NE2, 3 W/O Exhaust Ventilation Delivery.....	42

GETTING OTHER INFORMATION AND PUBLICATIONS

These publications can help when installing the air conditioner. They can usually be found at the local library or purchased directly from the publisher. Be sure to consult the current edition of each standard.

National Electrical Code.....ANSI/NFPA 70

Standard for the Installation of Air Conditioning and Ventilating Systems
.....ANSI/NFPA 90A

Standard for Warm Air Heating and Air Conditioning Systems
.....ANSI/NFPA 90B

Load Calculation for Winter and Summer Air Conditioning
..... ACCA Manual J Residential

Duct Design for Residential Winter and Summer Air Conditioning and Equipment Selection
..... ACCA Manual D

For more information, contact these publishers:

ACCA **Air Conditioning Contractors of America**
1712 New Hampshire Ave. N.W.
Washington, DC 20009
Telephone: (202) 483-9370
Fax: (202) 234-4721

ANSI **American National Standards Institute**
11 West Street, 13th Floor
New York, NY 10036
Telephone: (212) 642-4900
Fax: (212) 302-1286

ASHRAE **American Society of Heating, Refrigeration and Air Conditioning Engineers, Inc.**
1791 Tullie Circle, N.E.
Atlanta, GA 30329-2305
Telephone: (404) 636-8400
Fax: (404) 321-5478

NFPA **National Fire Protection Association**
Batterymarch Park
P.O. Box 9101
Quincy, MA 02269-9901
Telephone: (800) 344-3555
Fax: (617) 984-7057

WALL MOUNT GENERAL INFORMATION

AIR CONDITIONER WALL MOUNT MODEL NOMENCLATURE

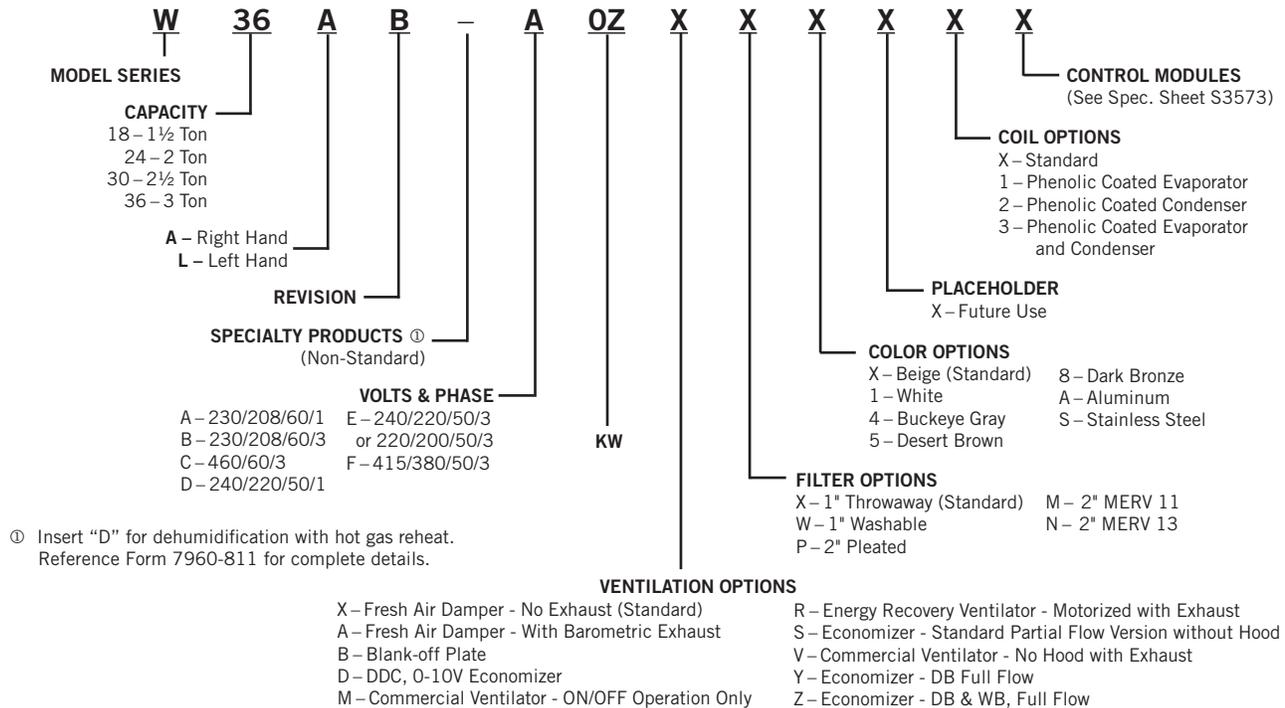

NOTE: Vent options X and B are without exhaust capability. May require separate field-supplied barometric relief in building.

Shipping Damage

Upon receipt of equipment, the carton should be checked for external signs of shipping damage. If damage is found, the receiving party must contact the last carrier immediately, preferably in writing, requesting inspection by the carrier's agent.

General

The equipment covered in this manual is to be installed by trained, experienced service and installation technicians.

This appliance is not intended for use by persons (including children) with reduced physical, sensory or mental capabilities, or lack of experience and knowledge, unless they have been given supervision or instruction concerning use of the appliance by a person responsible for their safety.

Children should be supervised to ensure that they do not play with the appliance.

The refrigerant system is completely assembled and charged. All internal wiring is complete.

The unit is designed for use with or without duct work. Flanges are provided for attaching the supply and return ducts.

These instructions explain the recommended method to install the air cooled self-contained unit and the electrical wiring connections to the unit.

These instructions and any instructions packaged with any separate equipment required to make up the entire air conditioning system should be carefully read before beginning the installation. Note particularly "Starting Procedure" and any tags and/or labels attached to the equipment.

While these instructions are intended as a general recommended guide, they do not supersede any national and/or local codes in any way. Authorities having jurisdiction should be consulted before the installation is made. See page 3 for information on codes and standards.

Size of unit for a proposed installation should be based on heat loss calculation made according to methods of Air Conditioning Contractors of America (ACCA). The air duct should be installed in accordance with the Standards of the National Fire Protection Association for the Installation of Air Conditioning and Ventilating Systems of Other Than Residence Type, NFPA No. 90A, and Residence Type Warm Air Heating and Air Conditioning Systems, NFPA No. 90B. Where local regulations are at a variance with instructions, installer should adhere to local codes.

Duct Work

All duct work, supply and return, must be properly sized for the design airflow requirement of the equipment. Air Conditioning Contractors of America (ACCA) is an excellent guide to proper sizing. All duct work or portions thereof not in the conditioned space should be properly insulated in order to both conserve energy and prevent condensation or moisture damage.

Refer to Maximum ESP of Operation Electric Heat Table 17 on page 37.

Design the duct work according to methods given by the Air Conditioning Contractors of America (ACCA). When duct runs through unheated spaces, it should be insulated with a minimum of 1" of insulation. Use insulation with a vapor barrier on the outside of the insulation. Flexible joints should be used to connect the duct work to the equipment in order to keep the noise transmission to a minimum.

Model series W18 and W24 are approved for 0" clearance to the supply duct. For model series W30 and W36, a 1/4" clearance to combustible material for the first 3' of duct attached to the outlet air frame is required. See wall mount installation instructions beginning on page 6 and Figures 3 – 7 (pages 11 – 15) for further details.

Ducts through the walls must be insulated and all joints taped or sealed to prevent air or moisture entering the wall cavity.

Some installations may not require a return air duct. A metallic return air grille is required with installations not requiring a return air duct. The spacing between louvers on the grille shall not be larger than 5/8".

Any grille that meets with 5/8" louver criteria may be used. It is recommended that Bard Return Air Grille Kits RG2 through RG3 or RFG2 through RFG3 be installed when no return duct is used. Contact distributor or factory for ordering information. If using a return air filter grille, filters must be of sufficient size to allow a maximum velocity of 400 fpm.

NOTE: *If no return air duct is used, applicable installation codes may limit this cabinet to installation only in a single story structure.*

Filters

A 1" throwaway filter is standard with each unit. The filter slides into position making it easy to service. This filter can be serviced from the outside by removing the filter access panel. Additional 1" and 2" filters are also available as optional accessories. The internal filter brackets are adjustable to accommodate the 2" filter by bending two tabs down on each side of the filter support bracket.

Fresh Air Intake

All units are built with fresh air inlet slots punched in the service door.

If the unit is equipped with a fresh air damper assembly, the assembly is shipped already attached to the unit. The damper blade is locked in the closed position. To allow the damper to operate, the maximum and minimum blade position stops must be installed (see Figure 1).

Graphs found on pages 41 and 42 give approximate fresh air amounts based on the blade position stop location.

All capacity, efficiency and cost of operation information is based upon the fresh air blank-off plate in place and is recommended for maximum energy efficiency.

The blank-off plate is available upon request from the factory and is installed in place of the fresh air damper shipped with each unit.

FIGURE 1
Fresh Air Damper

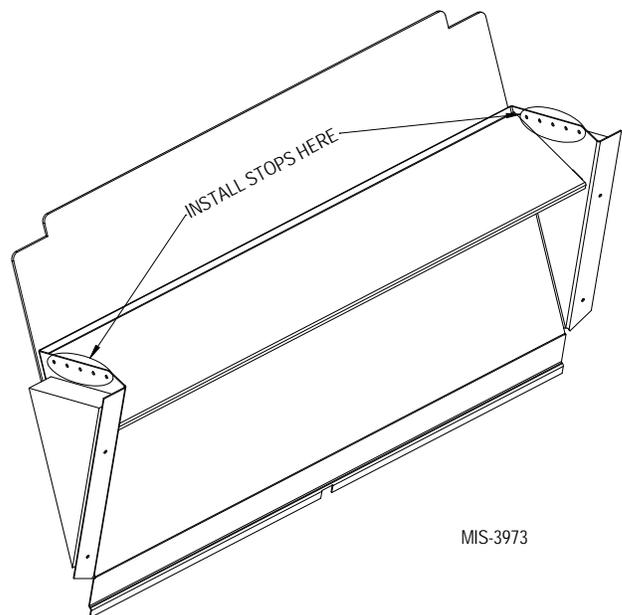

INSTALLATION

Basic Installation Design and Application Planning

Successful unit installations require proper planning and site inspection before installation begins. Before installing the wall mount unit, make sure that all service and airflow clearances are met and that the unit can meet all applicable code and regulation requirements. Provide an inspection of both the inside and outside of the structure by reviewing floorplans and/or visiting the installation site.

Wall Construction

The wall must be inspected to ensure that the weight of the unit can be supported. Be sure to review all applicable construction codes and regulations including seismic requirements. When inspecting wood frame walls, the wall construction must be strong and rigid enough to carry the weight of the unit without transmitting any unit vibration. It is important that the side unit wall mounting lags and optional bottom bracket are supported by structural members inside the wall cavity. Concrete block and brick walls must be thoroughly inspected to ensure that they are capable of carrying the weight of the installed unit. Metal buildings must contain structural components to support the unit weight. If heavily corrugated siding is present, it may need to be trimmed and flashed similar to a window to provide a flat, even surface to attach and seal the unit to the wall. Heavy gauge corrugations that would be present on shipping containers and blast-proof structures may require the installation of a metal plate over the corrugated area. It is important that the unit area is weatherized and sealed to avoid air and water infiltration into the area between the unit and the wall.

Outdoor Area Inspection

Inspect the outdoor area of the jobsite or review construction plans and locate the area where the wall mount is to be installed. The outdoor area must be free from obstructions including fences, bushes and walls that will hinder unit operation regarding outdoor condenser airflow and unit serviceability. Do not install units in enclosed areas that limit the amount of ambient temperature airflow. Warm air will exit the front condenser section of the unit, and outdoor ambient temperature air must be able to enter side intake condenser openings of the unit. Portable or modular building placement must be in a way that the wall mount units have a constant supply of outdoor air for proper unit operation. Make sure that the service panels of the unit are accessible. Inspect wall surfaces for obstructions that could hinder unit installation and servicing including outdoor electrical conduits, junction boxes, wall drains, vent hoods, windows, doors, overhangs and posts.

Condensate Water Drainage

Review all codes and requirements for unit condensate drainage. A clear, flexible PVC drain hose (3/4" ID, 1" OD) extends from the drain pan in the upper section of the unit and extends down to the unit base. An opening is supplied towards the back of the unit base for the drain hose to pass through, and the hose extends 1" to 2" below the unit base. Water removed from the indoor air (condensate) will be expelled from the unit in large amounts during cooling operation through the hose. Units running in cooling operation in cold outdoor below freezing conditions can cause the condensate to freeze after leaving the drain hose. In the event the drain hose is connected to a drain system of some type, it must be an open or vented type system to ensure proper drainage throughout seasonal use.

Indoor Ducted and Non-Ducted Applications

Air distribution inside the structure being conditioned plays an important role in making sure the area is a consistent temperature. Improper air distribution can result in areas being cooler or warmer, electrical equipment not receiving sufficient airflow or occupancy discomfort felt inside an area. Thermostat or indoor temperature sensor placement inside the area being conditioned also plays an important role in indoor climate control.

Indoor Supply Airflow

Indoor installation areas must provide a non-restrictive path for the conditioned supply air to leave supply grilles and registers. Inspect the area to ensure that all indoor portions of the room or rooms will have access to supply air. Ductwork may be used to ensure proper air circulation and all provided ductwork guidelines and clearances must be followed. Non-ducted applications must use a supply louver grille installed over the supply opening inside the room. Be sure to adjust supply deflectors to properly disperse the conditioned supply air to all parts of the room. Avoid closing sections of the supply grilles which would cause unneeded supply duct pressurization.

Indoor Return Airflow

A non-restrictive path for room air returning to the center section of the unit must be provided inside the room. Avoid placing objects including furniture, electronics equipment, equipment racks and cabinets directly in front of the unit return grilles and registers. Bard recommends at least 2' between solid objects and return grilles or registers. Ductwork may be used to ensure proper air circulation and all provided ductwork guidelines and clearances must be followed. Non-ducted applications must use a return louver grille installed over the return opening inside the room.

Ducted Applications

Field fabricated supply and return duct work may be installed inside the structure being conditioned. A short supply and/or return stub duct may be connected to the unit supply and return flanges before unit installation to help with duct connections inside the structure. Supply and return ducts must be properly sized for the design airflow requirement of the equipment. Air Conditioning Contractors of America (ACCA) is an excellent guide to proper sizing. All duct work or portions thereof not in the conditioned space should be properly insulated in order to conserve energy, reduce heat conductivity, and prevent condensation or moisture damage. Refer to Maximum External Static Pressure (ESP) of Operation Table 17 on page 37. Design the duct work according to methods given by the Air Conditioning Contractors of America (ACCA). When duct work is installed in unheated spaces, it should be insulated with a minimum of 1" of insulation. Use insulation with a vapor barrier on the outside of the insulation. Flexible joints should be used to connect the duct work to the equipment in order to keep the noise transmission to a minimum. Ducts through the walls must be insulated and all joints taped or sealed to prevent air or moisture from entering the wall cavity.

Model series W18 and W24 are approved for 0" clearance to the supply duct. For model series W30 and W36, a 1/4" clearance to combustible material for the first 3' of duct attached to the outlet air frame is required. See instructions on page 8 and Figures 3 – 7 (pages 11 – 15) for further details.

WARNING

Fire hazard.

Maintain minimum 1/4" clearance between the supply air duct and combustible materials in the first 3' of ducting.

Failure to do so could result in fire causing damage, injury or death.

Free Blow Applications

Some installations may not require extensive supply duct work throughout the structure and are referred to as free blow applications. A short field-fabricated supply duct must be used in the wall cavity to transition between the supply collar on the unit and the supply louver grille in the room. The duct must be properly insulated in order to conserve energy, reduce heat conductivity and prevent condensation or moisture damage. All joints must be taped or sealed to prevent air or moisture entering the wall cavity. Follow all clearances including distances to combustible materials and all instructions provided in this manual.

A non-restrictive metallic supply air grille with deflectors is required for free blow applications. Contact the local Bard distributor or visit www.bardhvac.com for ordering information.

A metallic return air grille is required for non-ducted applications. The spacing between louvers on the grille shall not be larger than 5/8". It is recommended that a Bard Return Air Grille Kit is installed that is designed specifically for the wall mount product. Contact the local Bard distributor or visit www.bardhvac.com for ordering information. A field-supplied return grille that meets the 5/8" louver criteria and does not cause the unit to exceed the maximum specified external static pressure (ESP) may be used. If using a return air filter grille, filters must be of sufficient size to allow a maximum velocity of 400 fpm. Filter return air grilles do not filter air being brought into the structure through ventilation options including fresh air dampers, ventilators, economizers and energy recovery ventilators. Be sure to install the return grille with the louvers pointed downward towards the floor. This will help ensure return air is drawn upward from the floor and improve air circulation in the room.

NOTE: *If no return air duct is used, applicable installation codes may limit this cabinet to installation only in a single story structure.*

Thermostat or Indoor Temperature Sensor Placement

The location and installation of the thermostat or temperature sensor that monitors indoor temperature is very important regarding unit operation. Avoid placing the thermostat in an area exposed to direct sunlight or air from doorways leading outdoors. Use a piece of insulating material to close off conduit openings or holes in the wall surface for wire entry into the thermostat or temperature sensor. This will help avoid non-conditioned air from entering the thermostat and effecting temperature and/or humidity readings. As common practice, the thermostat or temperature sensor should measure the temperature of the air being returned to the unit, and not the conditioned air being supplied by the unit. Placing the thermostat or temperature sensor near a return air opening will normally result in optimal unit performance.

Unit Installation

Make sure to have the proper tools at the work site that are needed for unit installation. The following steps are provided to ensure the unit is installed properly to the wall surface, and that the unit will provide years of service with minimal service requirements.

Materials/Tools List

Additional hardware and miscellaneous supplies are needed for installation. These items are field supplied and must be sourced before installation. The following list also includes tools needed for installation.

- Appropriate safety gear including gloves and safety glasses
 - 5/16" hex bit with drill driver
 - Phillips head screwdriver
 - Small straight (thermostat) screwdriver
 - Tape measure
 - Leveling device
 - Two (2) tubes of caulk and caulk gun
 - Utility knife
 - Tools for cutting holes in the wall surface (if needed)
 - Electrical components and wiring along with electrical tools
 - Multimeter
 - Wall fasteners for side flanges, bottom mounting bracket and top rain flashing.
 - Duct tape and/or other duct sealing materials.
2. Locate and mark bolt hole locations and bottom mounting bracket location. Install bottom mounting bracket with field-supplied fasteners to wall if it is to be used (optional). Bracket must be level and installed in the correct location to help support the unit during the installation process (see Figures 3A and 3B).
 3. Position the wall mount unit close to the wall surface where it will be installed. Install rain flashing at the top of the unit facing the wall by hooking the hem bend into the rear bend of the unit top (see Figures 3A and 3B).
 4. Apply a liberal amount of caulk on left and right cabinet side wall mount brackets and back of top rain flashing. Place unit back surface flush against wall. Unit must be level to ensure proper condensate drainage. Optional bottom bracket may be used to help support the unit.
 5. Units are secured to the wall by using field-supplied fasteners along each side of the wall mount through the built-in wall mounting brackets. It is the responsibility of the installer to select the proper fastener to secure the unit to the wall based on wall construction and applicable building codes. Typical installations may include 5/16" fasteners with 7/8" diameter flat washers. Be sure unit is securely mounted and all weight-bearing fasteners are attached to the weight supporting structural members of the wall.

Wall Preparation

1. Two holes for the supply and return air openings must be cut through the wall as shown in Figures 3A and 3B on pages 11 and 12. Be sure the openings are square and level. Follow all clearances including distances to combustible materials and all instructions provided in this manual.
2. Review all electrical requirements provided in this manual and plan out electrical entrances into the building. Also plan electrical conduit routing and thermostat placement, if necessary.
3. Install necessary duct work and prepare the openings for unit installation.
4. Clean the exterior wall where the unit is to be installed and make sure it is able to provide a smooth, level, debris-free surface. Remove all construction debris from the supply, return and electrical hole cutting process.
6. Apply a bead of caulk between the back of the unit top and the front surface of the top rain flashing (see Figures 3A and 3B).
7. Connect unit duct work from the inside of the building following all clearances and instructions provided. For additional mounting rigidity, the return air and supply air frames or collars can be drilled and screwed or welded to the structural wall itself (depending upon wall construction). Be sure to use code approved duct tape or other sealing materials to seal the duct work to the unit.

Wall Mount Installation to Wall Surface

1. Remove packaging from unit and make sure the unit is not damaged before installation. A top rain flashing is supplied for field use and is mounted to the back of the unit for shipping. Remove the rain flashing before locating the unit against the wall. Top rain flashing is required to avoid water entering the area behind the unit that is against the wall. A bottom mounting bracket, attached to the skid for shipping, is provided for ease of installation but is not required. Review all requirements listed on unit labels and on serial plate located on the side of the unit.
8. On side-by-side installations, maintain a minimum of 20" clearance on right side (on W**A units) to allow access to control panel and heat strips and proper airflow to the outdoor coil (20" clearance on left side on W**L units). Additional clearance may be required to meet local or national codes.

TABLE 1
Clearance Required for Service Access and
Adequate Condenser Airflow

Model	Left Side	Right Side	Discharge Side
W18A W24A W30A W36A	15"	20"	10'
W18L W24L W30L W36L	20"	15"	10'

NOTE: For side-by-side installation of two W**A models, there must be 20" between units. This can be reduced to 15" by using a W**L model (left side compressor and controls) for the left unit and W**A (right side compressor and controls) for right unit.

See Specifications Sheet S3573.

TABLE 2
Minimum Clearances Required
to Combustible Materials

Model	Supply Air Duct (1st 3')	Cabinet
W18A, L W24A, L	0"	0"
W30A, L W36A, L	1/4"	0"

FIGURE 2
Unit Dimensions

	Width (W)	Depth (D)	Height (H)	Supply		Return		E	F	G	I	J	K	L	M	N	O	P	Q	R	S	T
				A	B	C	B															
W18*B W24*B	33.300	17.125	74.563	7.88	19.88	11.88	19.88	35.00	10.88	29.75	20.56	30.75	32.06	33.25	31.00	2.63	34.13	26.06	10.55	3.94	12.00	9.00
W30*B W36*B	38.200	17.125	74.563	7.88	27.88	13.88	27.88	40.00	10.88	29.75	17.93	30.75	32.75	33.25	31.00	2.75	39.13	26.75	9.14	3.94	12.00	9.00

All dimensions are in inches. Dimensional drawings are not to scale.

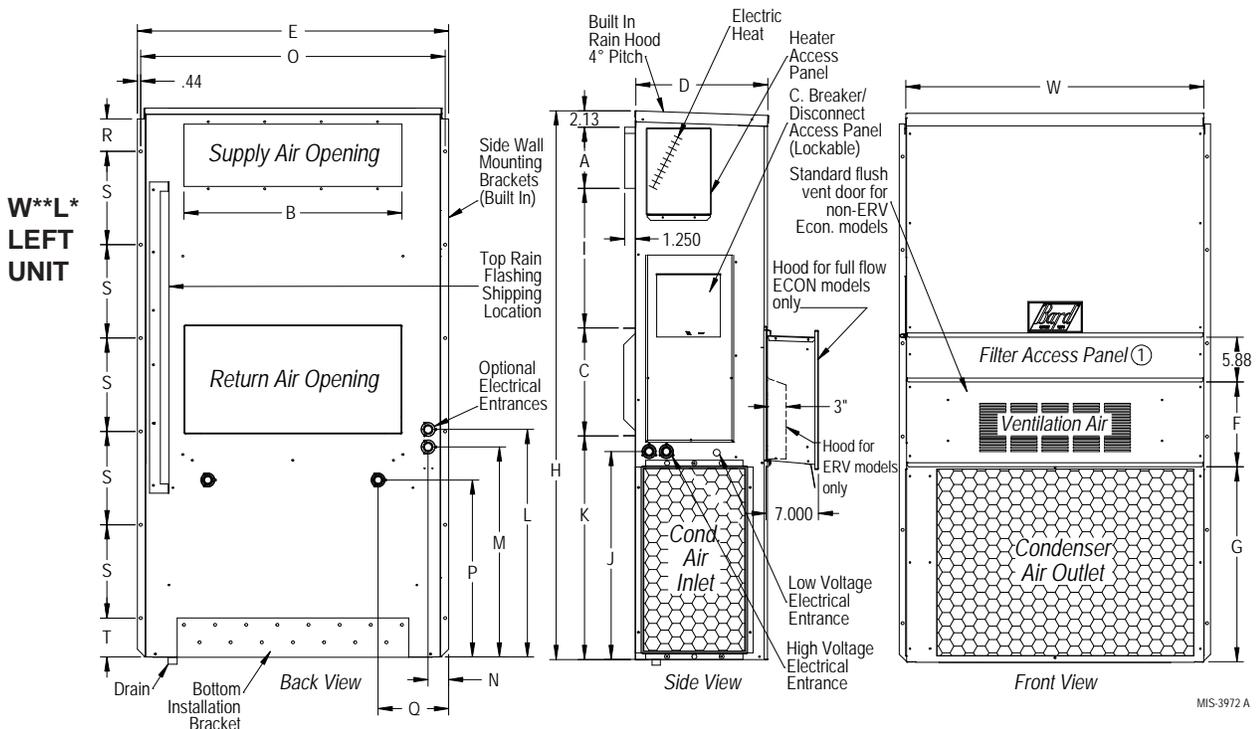
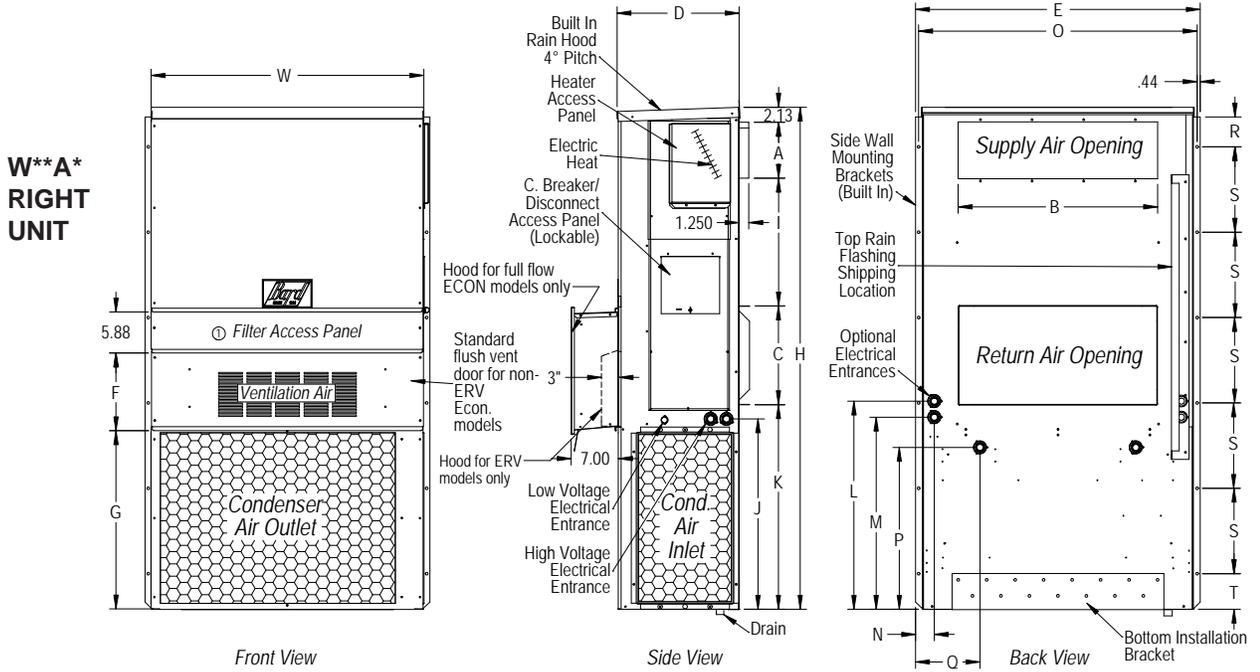
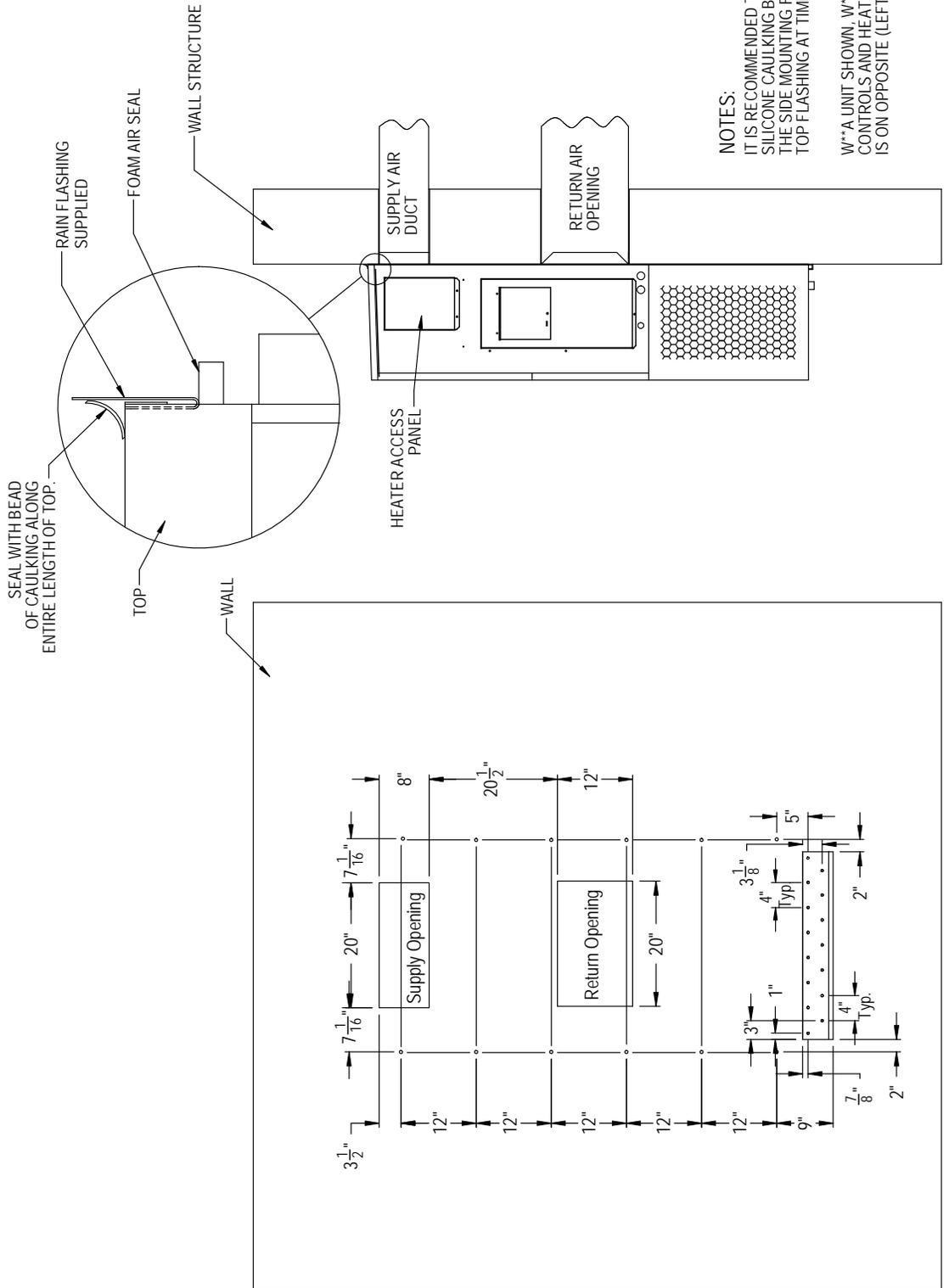

FIGURE 3A
W18AB, W18LB, W24AB, W24LB
Mounting Instructions



NOTES:
 IT IS RECOMMENDED THAT A BEAD OF SILICONE CAULKING BE PLACED BEHIND THE SIDE MOUNTING FLANGES AND UNDER TOP FLASHING AT TIME OF INSTALLATION.
 W**A UNIT SHOWN. W**L UNIT CONTROLS AND HEATER ACCESS IS ON OPPOSITE (LEFT) SIDE.

Right Side View

Wall Opening and Hole Location View

MIS-4036 A

FIGURE 3B
W30AB, W30LB, W36AB, W36LB
Mounting Instructions

	A	B	C	D	E
REQUIRED DIMENSIONS TO MAINTAIN 1/4" MIN. CLEARANCE FROM COMBUSTIBLE MATERIALS	28 3/8	8 3/8	5 3/8	3 3/4	17 5/8
REQUIRED DIMENSIONS TO MAINTAIN RECOMMENDED 1" CLEARANCE FROM COMBUSTIBLE MATERIALS	29 7/8	9 7/8	4 5/8	4 1/2	16 7/8

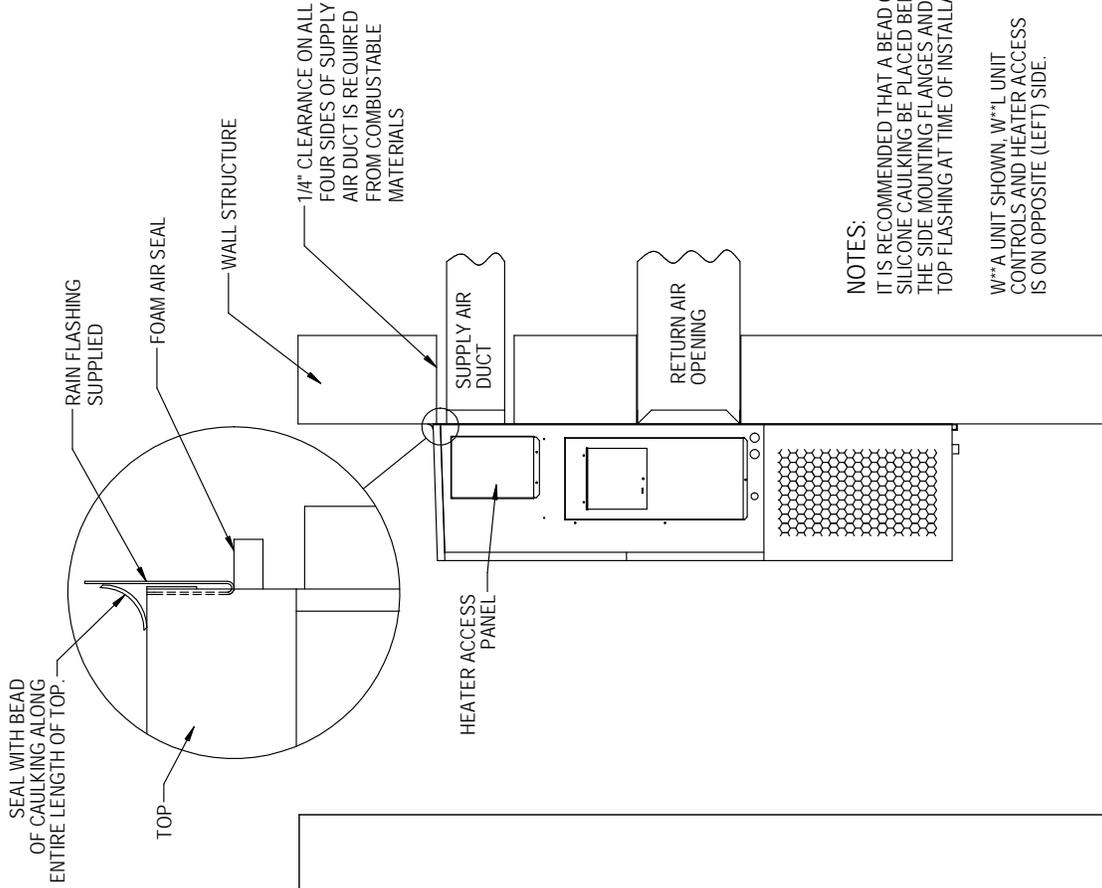

NOTES:
 IT IS RECOMMENDED THAT A BEAD OF SILICONE CAULKING BE PLACED BEHIND THE SIDE MOUNTING FLANGES AND UNDER TOP FLASHING AT TIME OF INSTALLATION.
 W**A UNIT SHOWN. W**L UNIT CONTROLS AND HEATER ACCESS IS ON OPPOSITE (LEFT) SIDE.

Right Side View

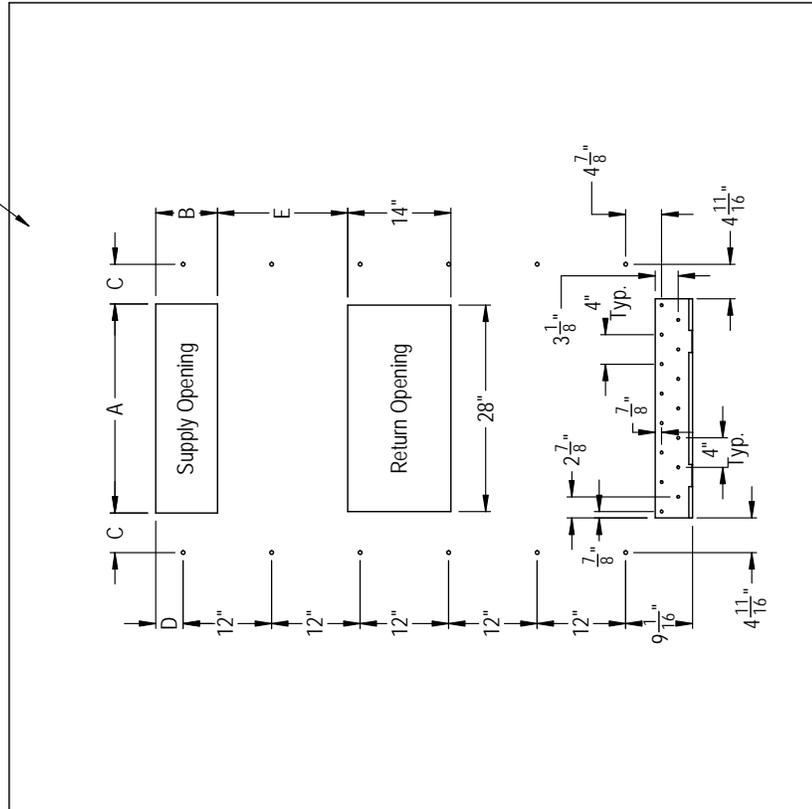

Wall Opening and Hole Location View

MIS-3820 A

FIGURE 4
Electric Heat Clearance
W30AB, W30LB, W36AB, W36LB

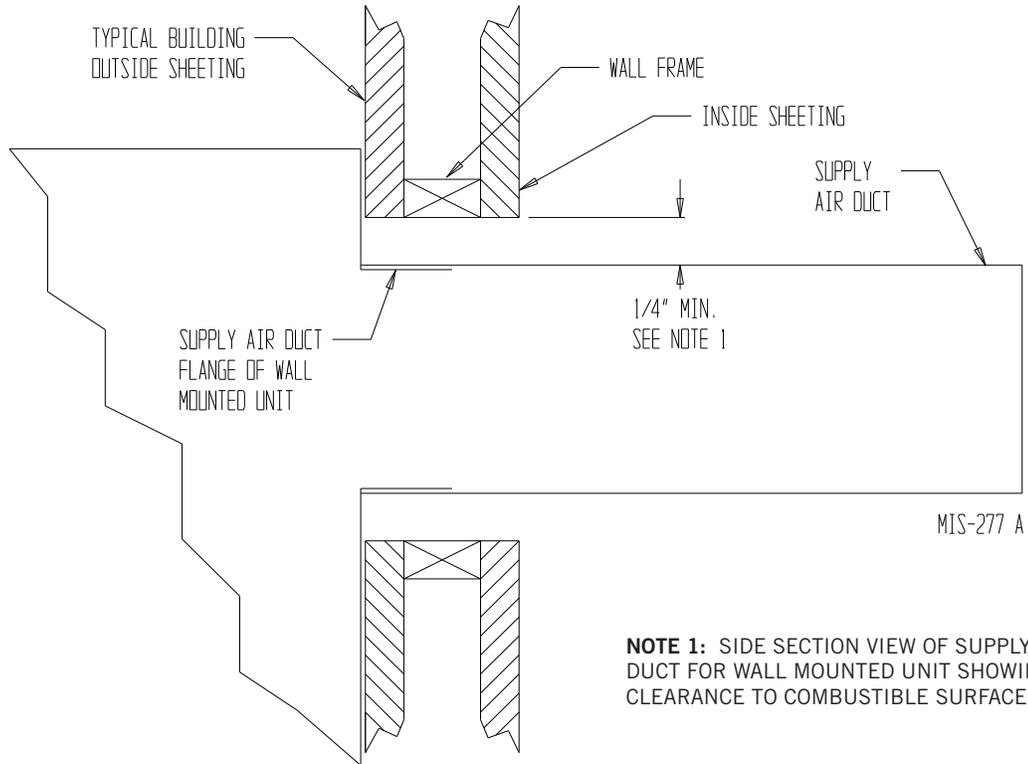

NOTE 1: SIDE SECTION VIEW OF SUPPLY AIR DUCT FOR WALL MOUNTED UNIT SHOWING 1/4" CLEARANCE TO COMBUSTIBLE SURFACES.

WARNING

Fire hazard.

Maintain minimum 1/4" clearance between the supply air duct and combustible materials in the first 3' of ducting.

Failure to do so could result in fire causing damage, injury or death.

FIGURE 5
Wall Mounting Instructions

See Figures 3A and 3B Mounting Instructions

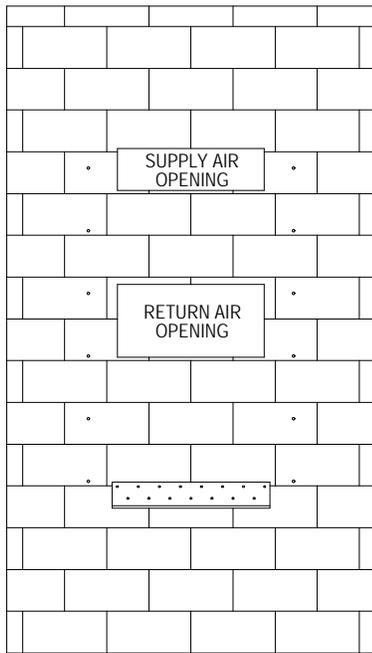

CONCRETE BLOCK WALL INSTALLATION

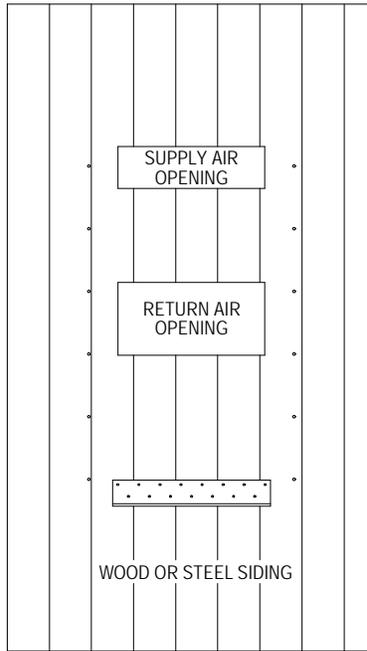

WOOD FRAME WALL INSTALLATION

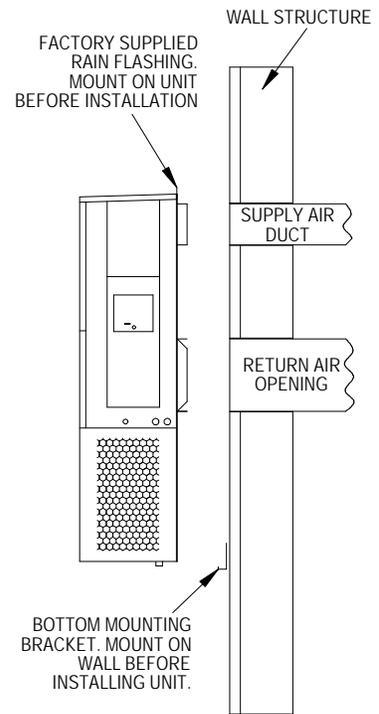

SIDE VIEW

MIS-548 A

FIGURE 6
Wall Mounting Instructions

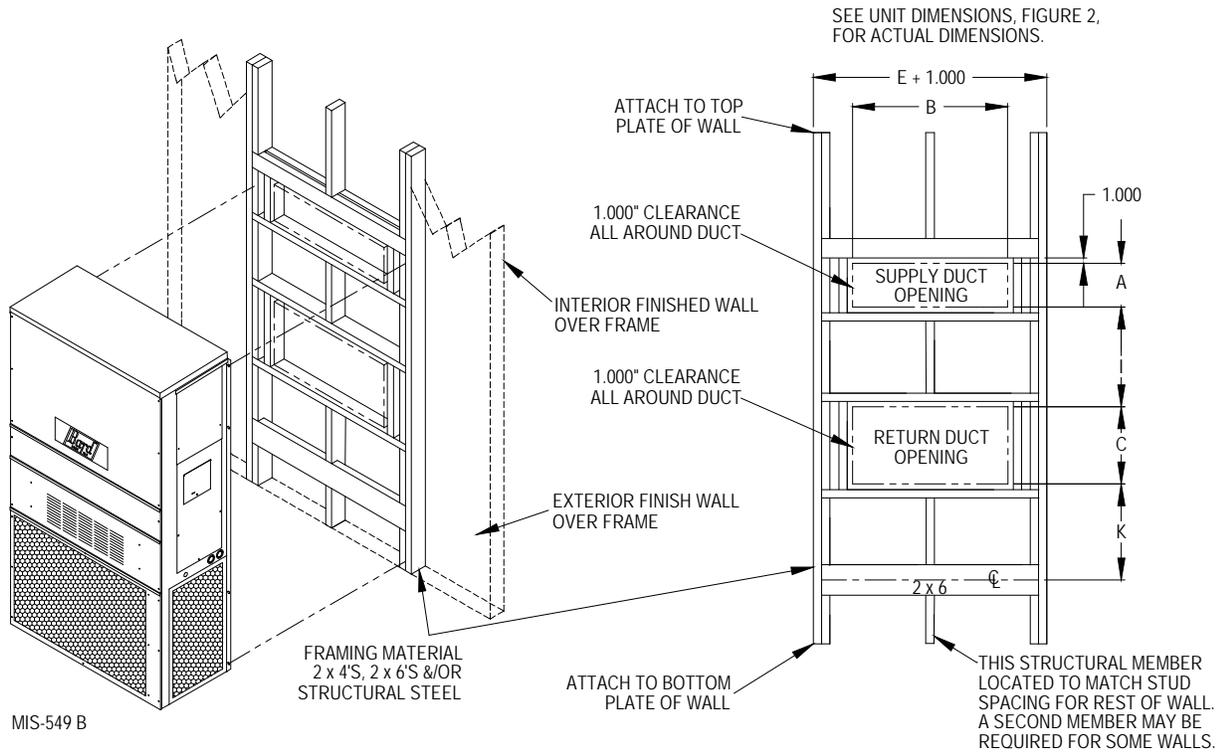

MIS-549 B

FIGURE 7
Common Wall Mounting Installations

Non-Ducted Installations

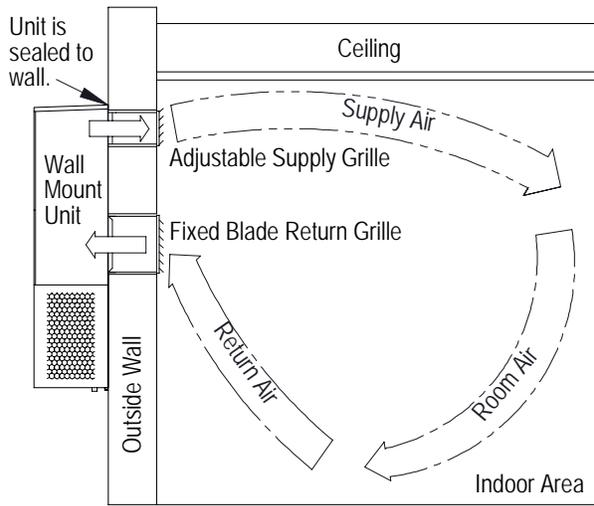

Non-ducted installations supply conditioned air into indoor room areas without extensive duct work. The supply airstream is directed by adjusting the 4-way supply grille to reach areas being conditioned. The supply air mixes with the room air and cools or heats occupants and/or equipment in the area. Unconditioned room air is returned to the unit through the return grille. Avoid supply air leaving supply grille and re-entering the unit return grille without mixing with room air.

Ducted Installations

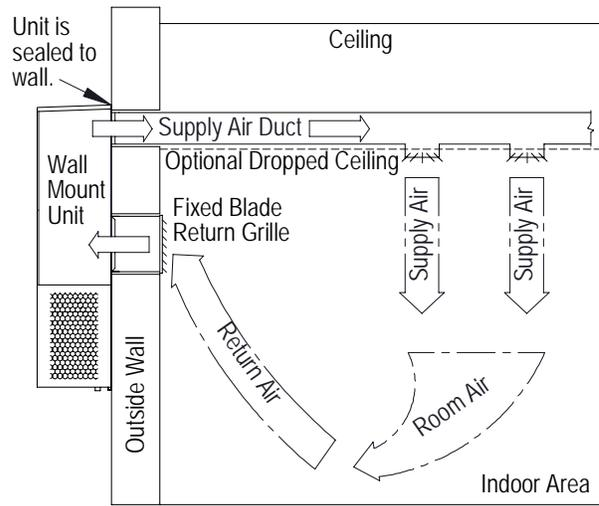

Ducted installations supply conditioned air into indoor room areas using solid or flexible ducts. The supply air is distributed throughout a single area or multiple areas. The supply air mixes with the room air and cools or heats occupants and/or equipment. Unconditioned room air is returned to the unit through a return grille or return duct work. Avoid using restrictive duct work to provide the best unit performance and efficiency. Review duct static pressure requirements provided in this manual.

Outdoor Wall Curb Installations

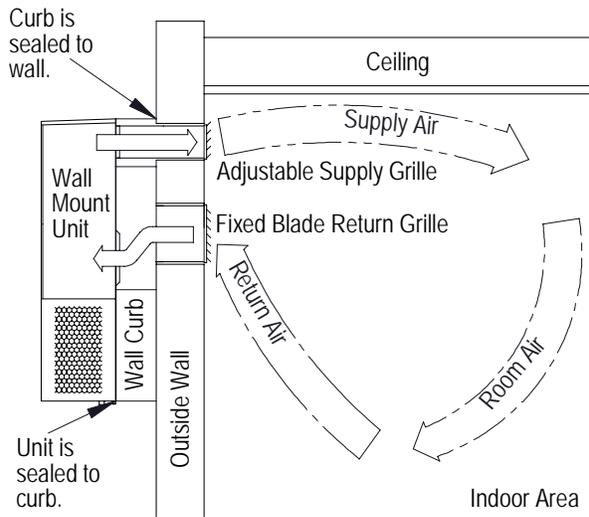

Outdoor Wall curbs are installed between the wall mount unit and the outer wall surface. Wall curb use may avoid resizing supply and return openings that are currently in an existing wall. Wall curbs may also provide sound isolation and indoor area sound reduction. Various curb options are available, and it is important to select a curb that will meet the application requirements and also be the correct size for the unit. Unit duct static requirements cannot be exceeded when using a wall curb. Follow all instructions provided with the wall curb when installing the product.

WAPR11 Indoor Sound Plenum Installations

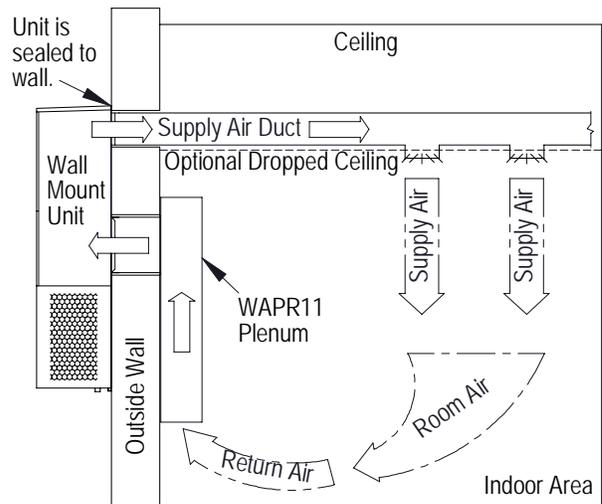

Indoor sound plenums are installed inside the room over the unit return air opening. Plenum use can provide sound isolation and indoor area sound reduction. The WAPR11 sound plenum provides a single solution for all unit tonnage sizes. The WAPR11 may be installed horizontally or vertically in the room. Unit duct static requirements cannot be exceeded when using a sound plenum. Follow all instructions provided with the sound plenum when installing the product.

MIS-550 D

Wiring – Main Power

WARNING

Electrical shock hazard.

Do not operate this equipment without an earth ground attached and always disconnect the remote electric power supplies before servicing.

Electrical shock can result in serious injury or death.

Refer to the unit rating plate for wire sizing information and maximum fuse or circuit breaker size. Each outdoor unit is marked with a “Minimum Circuit Ampacity”. This means that the field wiring used must be sized to carry that amount of current. Depending on the installed KW of electric heat, there may be two field power circuits required. If this is the case, the unit serial plate will so indicate. All models are suitable only for connection with copper wire. Each unit and/or wiring diagram will be marked “Use Copper Conductors Only”. These instructions **must be** adhered to. Refer to the National Electrical Code (NEC) for complete current carrying capacity data on the various insulation grades of wiring material. All wiring must conform to NEC and all local codes.

The electrical data lists fuse and wire sizes (75°C copper) for all models including the most commonly used heater sizes. Also shown are the number of field power circuits required for the various models with heaters.

The unit rating plate lists a “Maximum Time Delay Relay Fuse” or circuit breaker that is to be used with the equipment. The correct size must be used for proper circuit protection and also to ensure that there will be no nuisance tripping due to the momentary high starting current of the compressor motor.

The disconnect access door on this unit may be locked to prevent unauthorized access to the disconnect. To convert for the locking capability, bend the tab located in the bottom left-hand corner of the disconnect opening under the disconnect access panel straight out. This tab will now line up with the slot in the door. When shut, a padlock may be placed through the hole in the tab preventing entry.

See “Start Up” section for important information on three phase scroll compressor start ups.

See Tables 12 and 13 on pages 30 and 31 for electrical specifications.

Wiring – Low Voltage

All 230/208V 1 phase and 3 phase equipment have dual primary voltage transformers. All equipment leaves the factory wired on 240V tap. For 208V operation,

reconnect from 240V to 208V tap. The acceptable operating voltage range for the 240 and 208V taps are:

Tap: 240 Range: 253 – 216
Tap: 208 Range: 220 – 187

NOTE: *The voltage should be measured at the field power connection point in the unit and while the unit is operating at full load (maximum amperage operating condition).*

For low voltage wiring, an 18 gauge copper, color-coded cable is recommended. See Table 7 on page 18 for more information.

Low Voltage (24VAC) Connections

These units use a 24-volt AC low voltage circuit.

C terminal is the *24VAC common and is grounded.*

G terminal is the *indoor blower input.*

Y1 terminal is the *1st Stage input for cooling.*

Y2 terminal is the *2nd Stage compressor input for cooling* (if equipped with an economizer) or *Y2 disables Balanced Climate mode if the Y1-Y2 jumper is removed* (see page 22).

B/W1 terminal is the *1st stage electric heat.*

W2 terminal is the *2nd stage heat* (if equipped).

A terminal is the *ventilation input.* This terminal energizes any factory-installed ventilation option and indoor blower.

D terminal is the *dehumidification input.* If installed, this terminal energizes any factory-installed dehumidification option.

L terminal is *24 volt alarm active output.*

For units equipped with an alarm relay:

1 terminal is the *normally closed contact on the relay.*

2 terminal is the *normally open contact on the relay.*

3 terminal is the *common contact on the relay.*

See Table 3 for additional low voltage connections on auxiliary terminal strip.

Unit Shutdown Feature (Standard on All Models)

The RT terminal is the 24VAC transformer output, and the R terminal is the 24VAC hot terminal for the operation of the equipment. RT and R are connected with a brass jumper bar which can be removed and RT and R connected to an external NC (normally closed) contact such as a fire/smoke detector that will cause shutdown of the equipment upon activation.

Balanced Climate™ Feature (Standard on All Models)

All units are equipped with the capability of running in Balanced Climate mode. This mode is designed to enhance the comfort level by reducing the indoor airflow amount and extending the run time to help extract more humidity during cooling operation. The Y1 terminal is the 24VAC input for Balanced Climate compressor cooling operation. The Y2 terminal is the 24VAC input

TABLE 3
Additional Low Voltage Connections (if applicable)

Terminal	Unit	Description
9	V Control Option Only	Discharge Air Sensor, 10K Ohm
10	V Control Option Only	Discharge Air Sensor, 10K Ohm
11	F, V Control Options	Filter Switch, Normally Open Contact
12	F, V Control Options	Filter Switch, Normally Open Contact
13	V Control Option Only	Blower Airflow Switch, Normally Open Contact
14	V Control Option Only	Blower Airflow Switch, Normally Open Contact
15	V Control Option Only	Compressor Current Sensor, Normally Open Contact
16	V Control Option Only	Compressor Current Sensor, Normally Open Contact

for compressor cooling standard operation. Y1 and Y2 are connected with a brass jumper bar which can be removed to enable Balanced Climate mode. Units with an economizer will not have the brass jumper installed. Refer to vent manuals for instructions on how Balanced Climate works with each vent.

NOTE: *Units with mechanical dehumidification require an additional connection to be made when enabling Balanced Climate. Refer to dehumidification supplemental instructions for this step.*

To operate in Balanced Climate mode, a 2-stage cooling thermostat is required. The lower indoor airflow operation is overridden by utilizing a 2-stage thermostat. If the call for cooling is not satisfied within a given time frame or temperature differential (specified by the thermostat), the thermostat will send a signal to Y2 which then increases the blower speed back to the selected speed. See pages 32 – 34 for blower speed selection options.

Refer to page 22 for additional Balanced Climate requirements and limitations.

Dehumidification Feature (Optional)

The D terminal is the 24VAC input for dehumidification operation on dehumidification hot gas reheat equipped units. When 24VAC is applied to the D terminal, a 3-way valve solenoid is energized. The reheat coil located behind the evaporator coil is then active to reheat the supply air during cooling mode. This allows humidity to be removed from the air entering the unit without a large amount of sensible cooling capacity. During dehumidification, the indoor blower speed is reduced to help with the humidity removal. A humidity sensing thermostat or humidistat is required to control dehumidification operation.

Ventilation Features (Optional)

See ventilation instructions provided with unit for low voltage wiring.

Low Ambient Control (LAC)

The low ambient control is a pressure switch that is attached to the liquid line of the system and monitors high side pressure. Operation of the LAC occurs as outdoor temperatures drop below 60°F. On/Off and modulating controls are used which operate based on pressure changes caused by outdoor temperature changes. On/Off LAC operation cycles the condenser fan on/off to maintain desired liquid pressure while modulating LAC operation is factory adjusted and slows the condenser fan speed (rpm).

Outdoor Temperature Switch and Freeze Protection Thermostat

An outdoor temperature switch and an evaporator freeze protection thermostat is supplied with all units that have a low ambient control. The outdoor switch disables Balanced Climate mode (if enabled) when the temperature drops below 50°F. This prevents potential evaporator coil freeze up issues. For units with mechanical dehumidification, this switch must remain disconnected when Balanced Climate mode is not being used. Refer to unit wiring diagram. The freeze thermostat cuts out compressor operation if the evaporator begins to freeze up.

Alarm Relay Feature (Controls Option)

The alarm relay provides a set of NO (normally open) and NC (normally closed) pilot duty contacts that operate when the compressor control module locks out compressor operation because of a high or low system refrigerant pressure event.

DDC Controls Feature (Controls Option)

The DDC controls option provides additional sensors that can be used with a field-supplied advanced logic controller. The DDC controls option contains the following installed components:

Dirty Filter Switch Indicator (DFS)

The switch is adjustable and measures pressure drop across the unit filter surface. When pressure drop is higher than the switch setting, NO contacts are provided to indicate the filter needs to be serviced. Refer to page 34 for instructions on making switch adjustments.

Discharge Air Sensor

The discharge air sensor provides a temperature reading of the supply air leaving the unit. The sensor is a 10K OHM @ 77°F measuring device. It is installed in the supply airstream in the heater bracket.

Airflow Switch

The airflow switch measures the pressure differential between the blower inlet and outlet. It is located directly above the blower partition. Relay contacts (NO) are

provided for the DDC controls option that indicates the indoor blower assembly needs to be serviced.

Compressor Current Sensor

The compressor current sensor indicates when the compressor is operational by measuring amp draw. It is located inside the unit control panel. Relay contacts (NO) are provided to indicate the compressor is not operating. See Table 4 for low voltage connections for DDC control.

**TABLE 4
Low Voltage Connections for DDC Control**

	Standard Units	Units w/ Economizers
Fan Only	Energize G	Energize G
1st Stage Cooling Mode/ Balanced Climate	Energize Y1, G	Energize Y1, G
2nd Stage Cooling Mode	Energize Y2 to override Balanced Climate mode when Y1-Y2 jumper is removed	Energize Y1, Y2, G
1st Stage Heating	Energize B/W1	Energize B/W1
2nd Stage Heating (if employed)	Energize B/W1, W2	Energize B/W1, W2
Ventilation	Energize A	Energize A
Dehumidification (if employed)	Energize D	Energize D

**TABLE 5
Humidity Controls**

Part Number	Predominate Features
8403-038 (H600A1014)	SPDT switching, pilot duty 50VA @ 24V; Humidity range 20-80% RH
8403-047 (H200-10-21-10)	Electronic dehumidstat SPST closes-on-rise; Humidity range 10-90% with adjustable stops

**TABLE 6
CO₂ Controllers**

Part Number	Predominate Features
8403-056	CO ₂ ventilation control with digital display. Normally Open SPST (Default: Close at 800ppm)
8403-096	Normally Open SPST relay closes-on-rise 24V dual wave length sensor. Default setting 950ppm, adjustable to 0-2000ppm. Default off setting 1000ppm, adjustable to 0-200 ppm can be calibrated

**TABLE 7
Thermostat Wire Size**

Transformer VA	FLA	Wire Gauge	Maximum Distance In Feet
55	2.3	18 gauge	60
		16 gauge	100
		14 gauge	160
		12 gauge	250

**TABLE 8
Wall Thermostats**

Part Number	Predominate Features
8403-060 (1120-445)	3 stage Cool; 3 stage Heat; Electronic Programmable/Non-Programmable; HP or Conventional; Auto or Manual changeover; Dehumidification Output
CS9B-THOA	3 stage Cool, 3 stage Heat; Programmable/Non-Programmable; HP or Conventional; Auto or Manual Changeover; Humidity Sensor w/ dehumidification; Motion Sensor w/Intelligent Learning Control; BACnet-compatible
CS9B-THOCA	3 stage Cool, 3 stage Heat; Programmable/Non-Programmable; HP or Conventional; Auto or Manual Changeover; Humidity Sensor w/ dehumidification; CO ₂ Sensor; Motion Sensor w/Intelligent Learning Control; BACnet-compatible
CS9BE-THOA	3 stage Cool, 3 stage Heat; Programmable/Non-Programmable; HP or Conventional; Auto or Manual Changeover; Humidity Sensor w/ dehumidification; Motion Sensor w/Intelligent Learning Control; BACnet-compatible; Ethernet-compatible
CS9BE-THOCA	3 stage Cool, 3 stage Heat; Programmable/Non-Programmable; HP or Conventional; Auto or Manual Changeover; Humidity Sensor w/dehumidification; CO ₂ Sensor; Motion Sensor w/Intelligent Learning Control; BACnet-compatible; Ethernet-compatible
8403-089 (T4 Pro)	1 stage Cool, 1 stage Heat – Heat Pump; 1 stage Cool, 1 stage Heat – Conventional; Programmable/Non-Programmable Electronic; Auto or Manual changeover
8403-090 (T6 Pro)	2 stage Cool, 3 stage Heat – Heat Pump; 2 stage Cool, 2 stage Heat – Conventional; Programmable/Non-Programmable Electronic; Auto or Manual changeover
8403-091	1 stage Cool, 1 stage Heat; Non-Programmable; FEMA use
8403-092 (T6 Pro Wi-Fi)	2 stage Cool, 3 stage Heat – Heat Pump; 2 stage Cool, 2 stage Heat – Conventional; Programmable/Non-Programmable Electronic; Auto or Manual changeover; Wi-Fi

FIGURE 8
Programmable Thermostat Connections

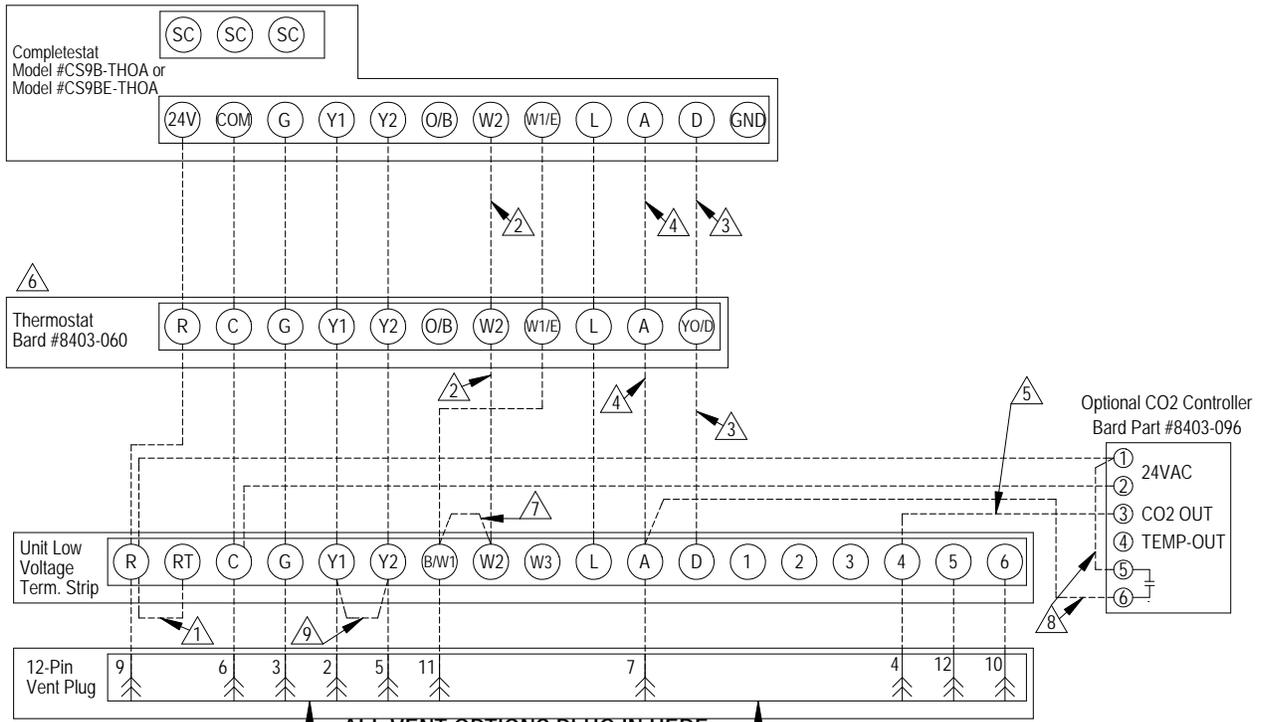

ALL VENT OPTIONS PLUG IN HERE
If not equipped with a ventilation option to plug in, a jumper plug must be installed.

- | | |
|--|--|
| <ul style="list-style-type: none"> △1 Factory installed jumper. Remove jumper and connect to N.C fire alarm circuit if emergency shutdown required. △2 Wire not needed below 15KW. △3 Wire required for dehumidification models only. △4 Do not connect "A" from thermostat if optional CO2 controller is used △5 0-10 VDC modulating CO2 control signal for modulating ventilation control (optional for ECON only - see vent instruction manuals) | <ul style="list-style-type: none"> △6 Change model configuration from heat pump to heat/cool. Must be configured to programmable and fan set to be programmed fan for the "A" output to function during scheduled occupied periods. Must be configured for multi-stage for Y1 output to be active 1st stage cooling. For dehumidification, must be configured for "No Economizer" for YO/D to be active for humidity control. △7 Install jumper for 1 stage electric heat on units with more than 10KW △8 Do not add these wires if setting up for modulating control. See note 5. △9 Factory installed jumper. Remove jumper to activate Balanced Climate™ mode. A 2-stage thermostat is recommended for Balanced Climate mode. Y1 Y2 jumper not present if economizer is factory installed. Units with economizers have balanced climate jumper in economizer, refer to economizer manual. |
|--|--|

MIS-3974D

FIGURE 9
Thermostat Connections

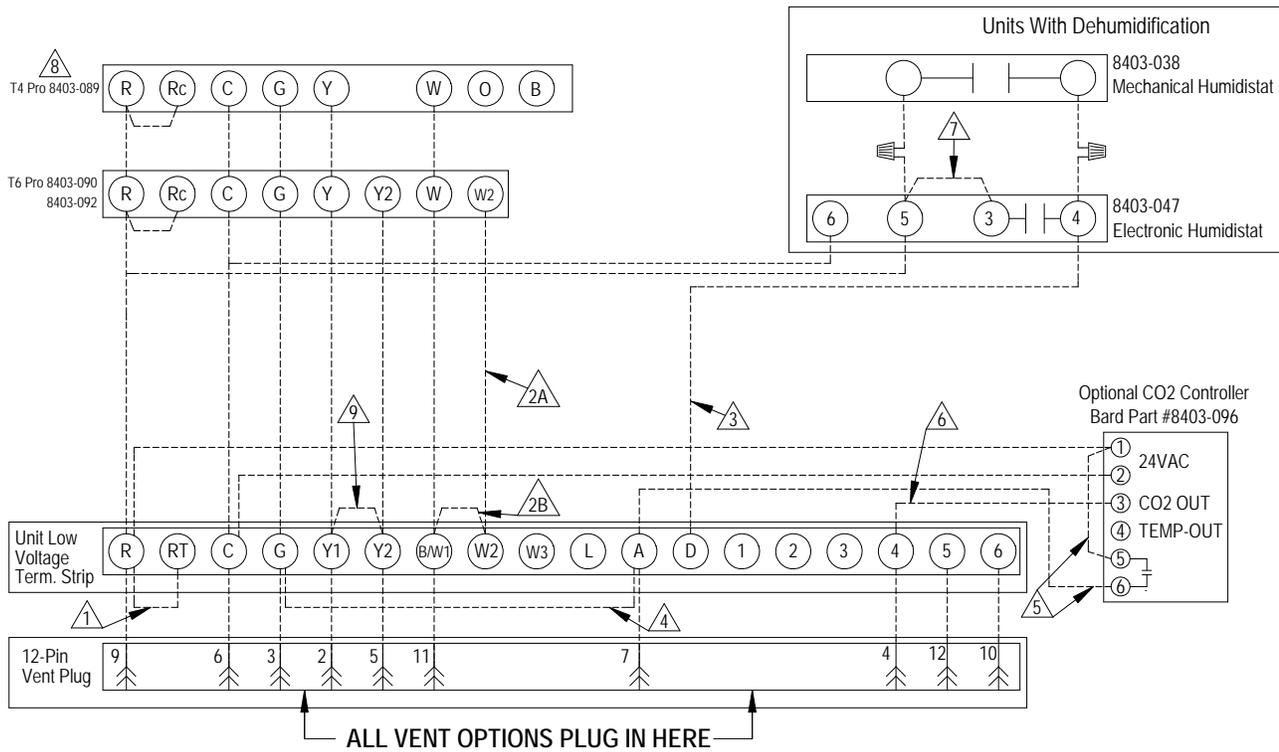

ALL VENT OPTIONS PLUG IN HERE

If not equipped with a ventilation option to plug in, a jumper plug must be installed.

- 1 Factory installed jumper. Remove jumper and connect to N.C fire alarm circuit if emergency shutdown required.
- 2A Wire not needed below 15KW.
- 2B Install Jumper for 1 stage electric heat on units with more than 10KW.
- 3 Wire required for dehumidification models only.
- 4 For vent operation, add jumper if optional CO2 controller is not used. Vent will run while blower is energized. For ECON & CRV-V an additional wire change is required See install Manual.
- 5 Do not add these wires if setting up for modulating control. See note 6.
- 6 0-10 VDC Modulating CO2 control signal for modulating ventilation control (Optional for ECON Only) - See vent installation manual.
- 7 Jumper needs added.
- 8 Thermostat will not work with units equipped with economizers.
- 9 Factory installed jumper. Remove jumper to activate Balanced Climate™ Mode. A 2-stage thermostat is recommended for Balanced Climate mode. Y1 Y2 jumper not present if economizer is factory installed. Units with economizers have balanced climate jumper in economizer, refer to economizer manual.

MIS-3975 E

NOTICE

These units require R-410A refrigerant and polyol ester oil.

General

1. Use separate service equipment to avoid cross contamination of oil and refrigerants.
2. Use recovery equipment rated for R-410A refrigerant.
3. Use manifold gauges rated for R-410A (800 psi/250 psi low).
4. R-410A is a binary blend of HFC-32 and HFC-125.
5. R-410A is nearly azeotropic—similar to R-22 and R-12. Although nearly azeotropic, charge with liquid refrigerant.
6. R-410A operates at 40-70% higher pressure than R-22 and systems designed for R-22 cannot withstand this higher pressure.
7. R-410A has an ozone depletion potential of zero, but must be reclaimed due to its global warming potential.
8. R-410A compressors use polyol ester oil.
9. Polyol ester oil is hygroscopic; it will rapidly absorb moisture and strongly hold this moisture in the oil.
10. A liquid line dryer must be used—even a deep vacuum will not separate moisture from the oil.
11. Limit atmospheric exposure to 15 minutes.
12. If compressor removal is necessary, always plug compressor immediately after removal. Purge with small amount of nitrogen when inserting plugs.

Topping Off System Charge

If a leak has occurred in the system, Bard Manufacturing recommends reclaiming, evacuating (see criteria above) and charging to the nameplate charge. If done correctly, topping off the system charge can be done without problems.

With R-410A, there are no significant changes in the refrigerant composition during multiple leaks and recharges. R-410A refrigerant is close to being an azeotropic blend (it behaves like a pure compound or single component refrigerant). The remaining refrigerant charge, in the system, may be used after leaks have occurred and then “top-off” the charge by utilizing the pressure charts on the inner control panel cover as a guideline.

REMEMBER: When adding R-410A refrigerant, it must come out of the charging cylinder/tank as a liquid to avoid any fractionation, and to ensure optimal system performance. Refer to instructions for the cylinder that is being utilized for proper method of liquid extraction.

Safety Practices

1. Never mix R-410A with other refrigerants.
2. Use gloves and safety glasses. Polyol ester oils can be irritating to the skin, and liquid refrigerant will freeze the skin.
3. Never use air and R-410A to leak check; the mixture may become flammable.
4. Do not inhale R-410A—the vapor attacks the nervous system, creating dizziness, loss of coordination and slurred speech. Cardiac irregularities, unconsciousness and ultimate death can result from breathing this concentration.
5. Do not burn R-410A. This decomposition produces hazardous vapors. Evacuate the area if exposed.
6. Use only cylinders rated DOT4BA/4BW 400.
7. Never fill cylinders over 80% of total capacity.
8. Store cylinders in a cool area, out of direct sunlight.
9. Never heat cylinders above 125°F.
10. Never trap liquid R-410A in manifold sets, gauge lines or cylinders. R-410A expands significantly at warmer temperatures. Once a cylinder or line is full of liquid, any further rise in temperature will cause it to burst.

Important Installer Note

For improved start up performance, wash the indoor coil with a dishwashing detergent.

High Pressure Switch

All W**A/W**L wall-mounted air conditioner series models are supplied with a remote reset for the high and low pressure switch. If tripped, the pressure switch may be reset by turning the thermostat off then back on again. High pressure switch settings: Opens 650 +/- 15 PSI, Closes 520 +/- 15 PSI.

Three Phase Scroll Compressor Start Up Information

Scroll compressors, like several other types of compressors, will only compress in one rotational direction. Direction of rotation is not an issue with single phase compressors since they will always start and run in the proper direction.

However, three phase compressors will rotate in either direction depending upon phasing of the power. Since there is a 50-50 chance of connecting power in such a way as to cause rotation in the reverse direction, verification of proper rotation must be made. Verification of proper rotation direction is made by observing that suction pressure drops and discharge pressure rises when the compressor is energized. Reverse rotation also results in an elevated sound level over that with correct rotation, as well as substantially reduced current draw compared to tabulated values.

Verification of **proper rotation** must be made at the time the equipment is put into service. If improper rotation is corrected at this time, there will be no negative impact on the durability of the compressor. However, reverse operation for over 1 hour may have a negative impact on the bearing due to oil pump out.

NOTE: *If compressor is allowed to run in reverse rotation for an extended period of time, the compressor's internal protector will trip.*

All three phase compressors are wired identically internally. As a result, once the correct phasing is determined for a specific system or installation, connecting properly phased power leads to the same Fusite terminal should maintain proper rotation direction.

The direction of rotation of the compressor may be changed by reversing any two line connections to the unit.

Phase Monitor

All units with three phase scroll compressors are equipped with a three phase line monitor to prevent compressor damage due to phase reversal.

The phase monitor in this unit is equipped with two LEDs. If the Y signal (call for cooling) is present at the phase monitor and phases are correct, the green LED will light.

If phases are reversed, the red fault LED will be lit and compressor operation is inhibited.

If a fault condition occurs, reverse two of the supply leads to the unit. **Do not reverse any of the unit factory wires as damage may occur.**

Condenser Fan Operation

NOTE: *Certain models may be equipped with a low ambient control (LAC), and if so, the condenser fan motor will have a delayed start until system refrigerant operating pressure builds up. After starting, the fan motor may or may not cycle depending upon ambient conditions. This is normal operation.*

50 Hz models must have fan wired on low speed. These models are factory wired on low speed.

Service Hints

1. Caution owner/operator to maintain clean air filters at all times and also not to needlessly close off supply and return air registers. This reduces airflow through the system, which shortens equipment service life as well as increasing operating costs.
2. Check all power fuses or circuit breakers to be sure they are the correct rating.
3. Periodic cleaning of the outdoor coil to permit full and unrestricted airflow circulation is essential.

Sequence of Operation

Circuit R-Y1 makes at thermostat pulling in compressor contactor, starting the compressor and outdoor motor. (See **NOTE** under **CONDENSER FAN OPERATION** concerning models equipped with low ambient control.) The G (indoor motor) circuit is automatically completed by the thermostat on any call for cooling operation or can be energized by manual fan switch on subbase for constant air circulation. On a call for heating, circuit R-W1 makes at the thermostat pulling in heat contactor for the strip heat and blower operation. On a call for second stage heat, R-W2 makes bringing on second heat contactor, if so equipped.

Balanced Climate™ Mode

Balanced Climate™ is a great comfort feature that can easily be applied under any normal circumstances. If the Bard air conditioning system is being set up in a typical environment where 72°F is the lowest cooling setpoint, remove the Y1/Y2 jumper and install a 2-stage cooling thermostat. This will increase the humidity removal up to 35% and provide a much more comfortable environment.

NOTE: *Units with mechanical dehumidification require an additional connection to be made when enabling Balanced Climate. Refer to dehumidification supplemental instructions for this step.*

If the application is likely to require air conditioning operation below 60°F outdoor conditions, a low ambient control (LAC) kit must be installed. The LAC kit is equipped with an outdoor temperature switch that disables Balanced Climate mode when the outdoor temperature drops below 50°F. This prevents potential evaporator coil freeze up issues. The LAC kit also comes with an evaporator freeze protection thermostat that cuts out the compressor if the evaporator begins to freeze up.

If the unit is being installed with any ventilation package, a Bard LAC kit must be installed. Failure to utilize an LAC with any air conditioner can cause coil freeze up.

Balanced Climate can readily be applied to duct-free (supply and return air grille) applications. It may also be applied to ducted applications with **limited static**

of 0.20" ESP (total including both supply and return statics). Consult Bard Application Engineering for details prior to implementation.

CAUTION: *Balanced Climate is not a replacement for a dehumidification (hot gas reheat) unit for extreme applications, but rather an enhancement feature for limited climates and applications.*

Vent Connection Plug

All units are equipped with a vent connection plug in the side of the control panel for the different ventilation packages to plug in to. If the compressor will not start and there is no "Y1" at the compressor control module, first check to make sure that either the optional vent is plugged into the vent connection plug or the supplied jumper plug is in place. **The unit will not operate without anything plugged in.** This plug is located on the side of the control panel behind the front vent door (behind the filter access door). If the unit is supplied with a factory-installed vent package, it will be plugged in but the jumper plug will also be tethered next to the connection for troubleshooting purposes, if necessary.

Compressor Control Module

The compressor control module (CCM) is standard on all models covered by this manual.

Features

- Delay-on-Make Timer
- Short Cycle Protection/Delay-on-Break
- Low Pressure Detection
- High Pressure Detection
- LPC and HPC Status LEDs
- Test Mode
- Brownout Protection with Adjustment

Delay-on-Make Timer

A delay-on-make timer is included to be able to delay startup of the compressor. This is desired when more than one unit is on a structure so that all of the units do not start at the same time which could happen after a power loss or building shutdown. The delay-on-make time period is 2 minutes plus 10% of the delay-on-break time period. To ensure that all of the units do not start at the same time, adjust the delay-on-break timer on each unit to a slightly different delay time.

Short Cycle Protection/Delay-on-Break

An anti-short cycle timer is included to prevent short cycling the compressor. This is adjustable from 30 seconds to 5 minutes via the adjustment knob (see Figure 10 on page 24). Once a compressor call is lost, the time period must expire before a new call will be initiated.

Low Pressure Detection

Low pressure switch monitoring allows for a lockout condition in a situation where the switch is open. If

the low pressure switch remains open for more than 2 minutes, the CCM will de-energize the compressor for the delay-on-break time. If the switch closes again, it will then restart the compressor. If the switch trips again during the same Y call, the compressor will be de-energized and the alarm terminal will be energized indicating an alarm. The blue LED will light and stay on until power is cycled to the control or a loss of voltage is present at Y terminal for more than ½ second.

High Pressure Detection

High pressure switch monitoring allows for a lockout condition in a situation where the switch is open. If the high pressure switch opens, the CCM will de-energize the compressor. If the switch closes again, it will then restart the compressor after the delay-on-break setting has expired on the device. If the switch trips again during the same thermostat call, the compressor will be de-energized and the alarm terminal will be energized indicating an alarm. The red LED will light and stay on until power is cycled to the control or a loss of voltage is present at Y terminal for more than ½ second.

Test Mode

By rapidly rotating the potentiometer (POT) clockwise (see Figure 10 on page 24), all timing functions will be removed for testing.

The conditions needed for the unit to enter test mode are as follows: POT must start at a time less than or equal to the 40 second mark. The POT must then be rapidly rotated to a position greater than or equal to the 280 second mark in less than ¼ second. Normal operation will resume after power is reset or after the unit has been in test mode for at least 5 minutes.

Brownout Protection with Adjustment

Brownout protection may be necessary if the utility power or generator power has inadequate power to prevent the voltage from dropping when the compressor starts. This is rare but can happen if the generator is undersized at the site or if the site is in a remote location far from the main power grid. Under normal circumstances, allowing the brownout to be ignored for a time period should not be needed. The 8201-169 is shipped with all the DIP switches in the 'off' or 'do not ignore' position (see Figure 10 on page 24).

If ignoring the brownout is needed because of the above conditions, three preset timers can be set by DIP switches in order to delay signaling a power brownout for a specific length of time after compressor contactor is energized. This allows the compressor a time period to start even if the voltage has dropped and allows the voltage to recover. This delay only happens when the CC terminal energizes. The delay can be set to 1 second (A DIP switch), 5 seconds (B DIP switch) or 10 seconds (C DIP switch); time is not cumulative—only

FIGURE 10
8201-169 Compressor Control Module

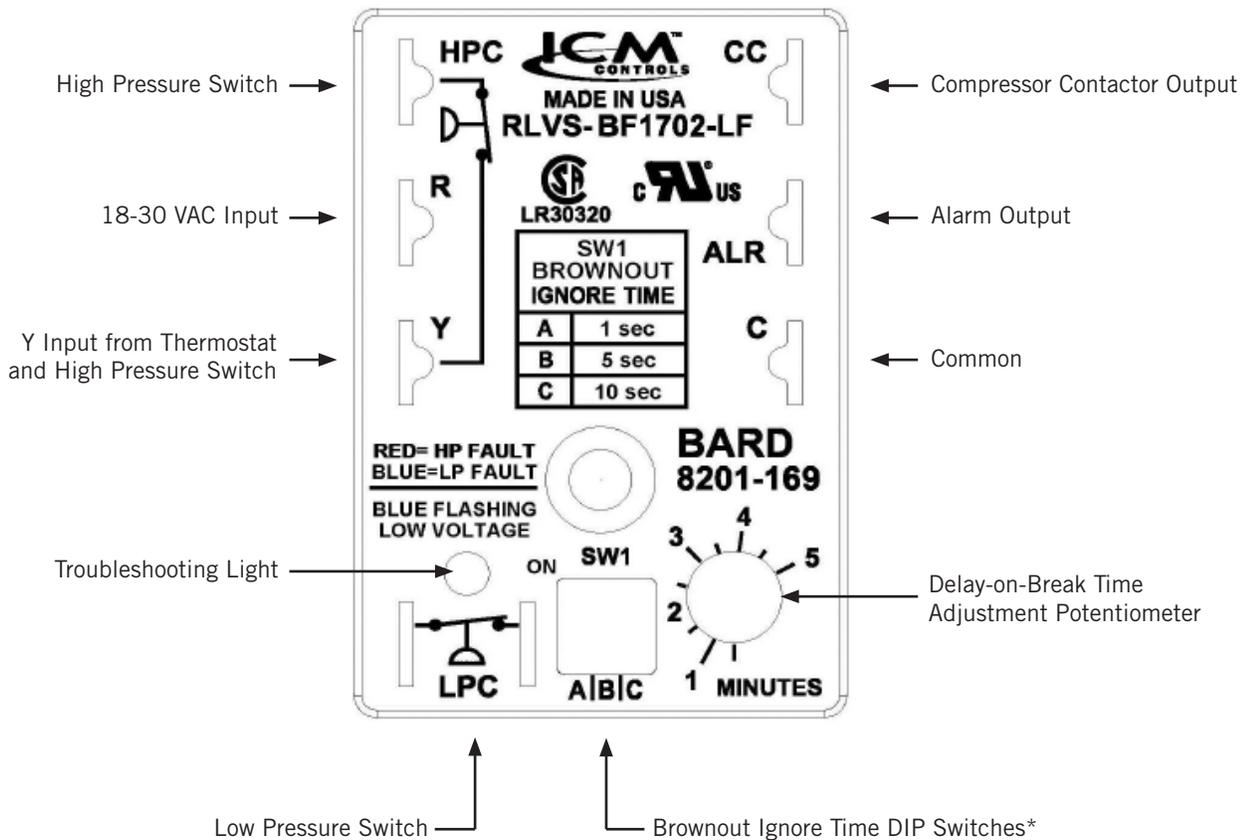

* Turn on only one switch for that specific ignore time setting. 10 seconds is the maximum brownout ignore time. If all switches are "off", the control is in "do not ignore".

the longest setting will apply. If the voltage recovers during the brownout delay period, the compressor will start.

If a brownout condition is detected by the 8201-169, the troubleshooting light will flash blue. The light will continue to flash until the cooling call is satisfied or power is removed from the Y terminal. This condition does not prevent operation, it only indicates that a brownout condition was present at some point during the cooling call. If a brownout condition is detected, CC will be de-energized and will retry after the delay-on-make timer is satisfied; this process will continue until call is satisfied.

If user chooses the 'do not ignore' position (all three DIP switches "off") when the site has inadequate utility or generator power, this could lead to the compressor never starting. The control will see the brownout immediately and not start.

A common scenario and one that has been seen in the field is when a unit or units switches from utility power to generator power. With slower transfer switches, the time delay between the utility power and generator power didn't cause a problem. The units lost power,

shut off and came back on line normally. With the introduction of almost instantaneous transfer switches, the millisecond long power glitch can be enough that the compressor will start to run backwards. In this scenario, the CCM will catch this and restart the units normally.

Pressure Service Ports

High and low pressure service ports are installed on all units so that the system operating pressures can be observed. Pressure tables covering all models can be found on pages 28 and 29. It is imperative to match the correct pressure table to the unit by model number.

This unit employs high-flow Coremax valves instead of the typical Shrader type valves.

WARNING! Do NOT use a Schrader valve core removal tool with these valves. Use of such a tool could result in eye injuries or refrigerant burns!

To change a Coremax valve without first removing the refrigerant, a special tool is required which can be obtained at www.fastestinc.com/en/SCCA07H. See the replacement parts manual for replacement core part numbers.

Troubleshooting NIDEC SELECTECH Series ECM Motors

If the Motor Is Running

1. It is normal for the motor to rock back and forth on start up. Do not replace the motor if this is the only problem identified.
2. If the system is excessively noisy, does not appear to change speeds in response to a demand (Heat, Cool, Other) or is having symptoms during the cycle such as tripping limit or freezing coil, check the following:
 - A. Wait for programmed delays to time out.
 - B. Ensure that the motors control inputs are wired as shown in the factory-supplied wiring diagram to ensure motor is getting proper control signals and sequencing.
 - C. Remove the filter and check that all dampers, registers and grilles are open and free flowing. If removing the filters corrects the problem, clean or replace with a less restrictive filter. Also check and clean the blower wheel or coil as necessary.

- D. Check the external static pressure (total of both supply and return) to ensure it is within the range as listed on the unit serial plate. If higher than allowed, additional duct work is needed.
- E. If the motor does not shut off at the end of the cycle, wait for any programmed delays to time out (no more than 90 seconds). Also make sure that there is no call for "Continuous Fan" on the G terminal.
- F. If the above diagnostics do not solve the problem, confirm the voltage checks in the next section below, then continue with the **Model SelectTech Communication Diagnostics**.

If the Motor Is Not Running

1. Check for proper high voltage and ground at the L/L1, G, N/L2 connections at the motor (see Figure 11). Correct any voltage issues before proceeding to the next step. The SelectTech motor is voltage specific. Only the correct voltage should be applied to the proper motor. Input voltage within plus or minus 10% of the nominal line power VAC is acceptable.

FIGURE 11
Motor Connections

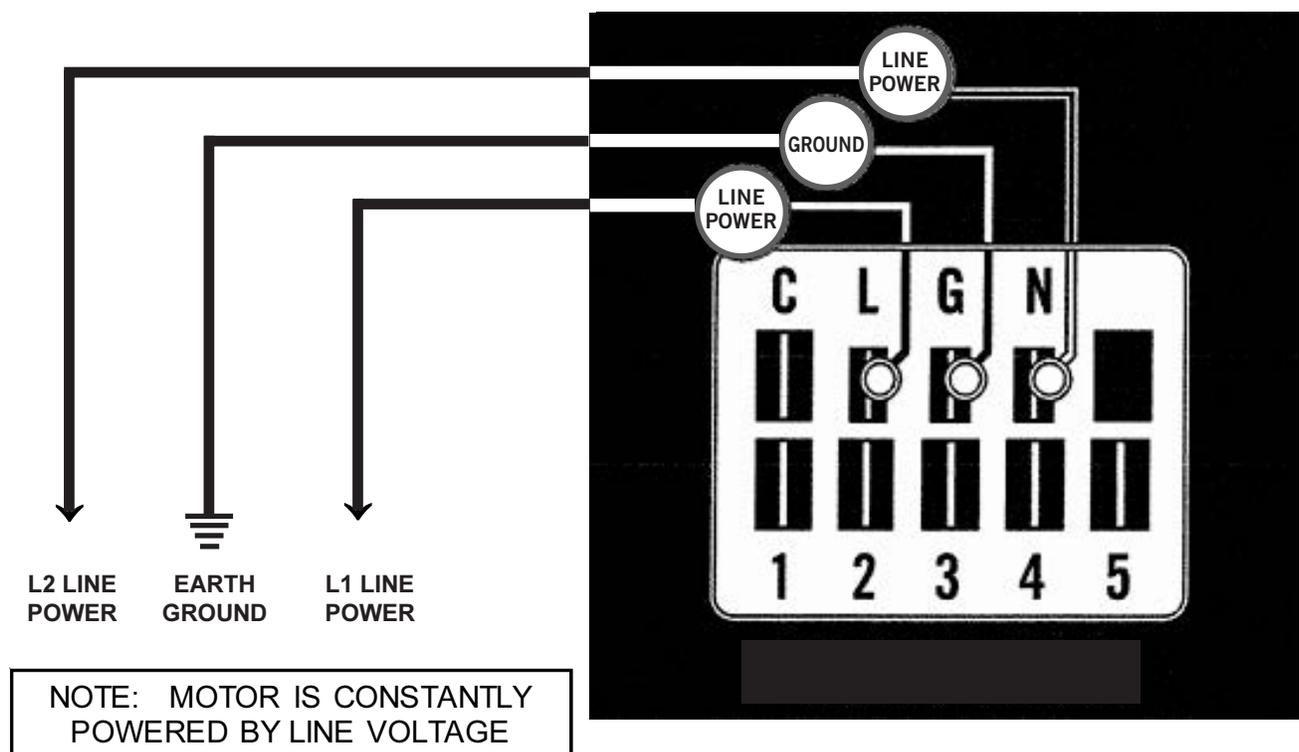

- If the motor has proper high voltage and ground at the L/L1, G, N/L2 connections, then continue with the **Model SelecTech Communication Diagnostics**.

Model SelecTech Communication Diagnostics

The SelecTech motor is communicated through 24 VAC low voltage (thermostat control circuit wiring).

- Start with unit wiring diagram to confirm proper connections and voltage (see Figure 12).
- Initiate a demand from the thermostat and check the voltage between the common and the appropriate motor terminal (1-5). (G input is typically on terminal #1, but always refer to wiring diagram.)

- If the low voltage communication is not present, check the demand from the thermostat. Also check the output terminal and wire(s) from the terminal strip or control relay(s) to the motor.
- If the motor has proper high voltage (verified in Step 1 of **If the Motor Is Not Running** on page 21), proper low voltage to a programmed terminal and is not operating, the motor is failed and will require replacement.

FIGURE 12
Motor Connections

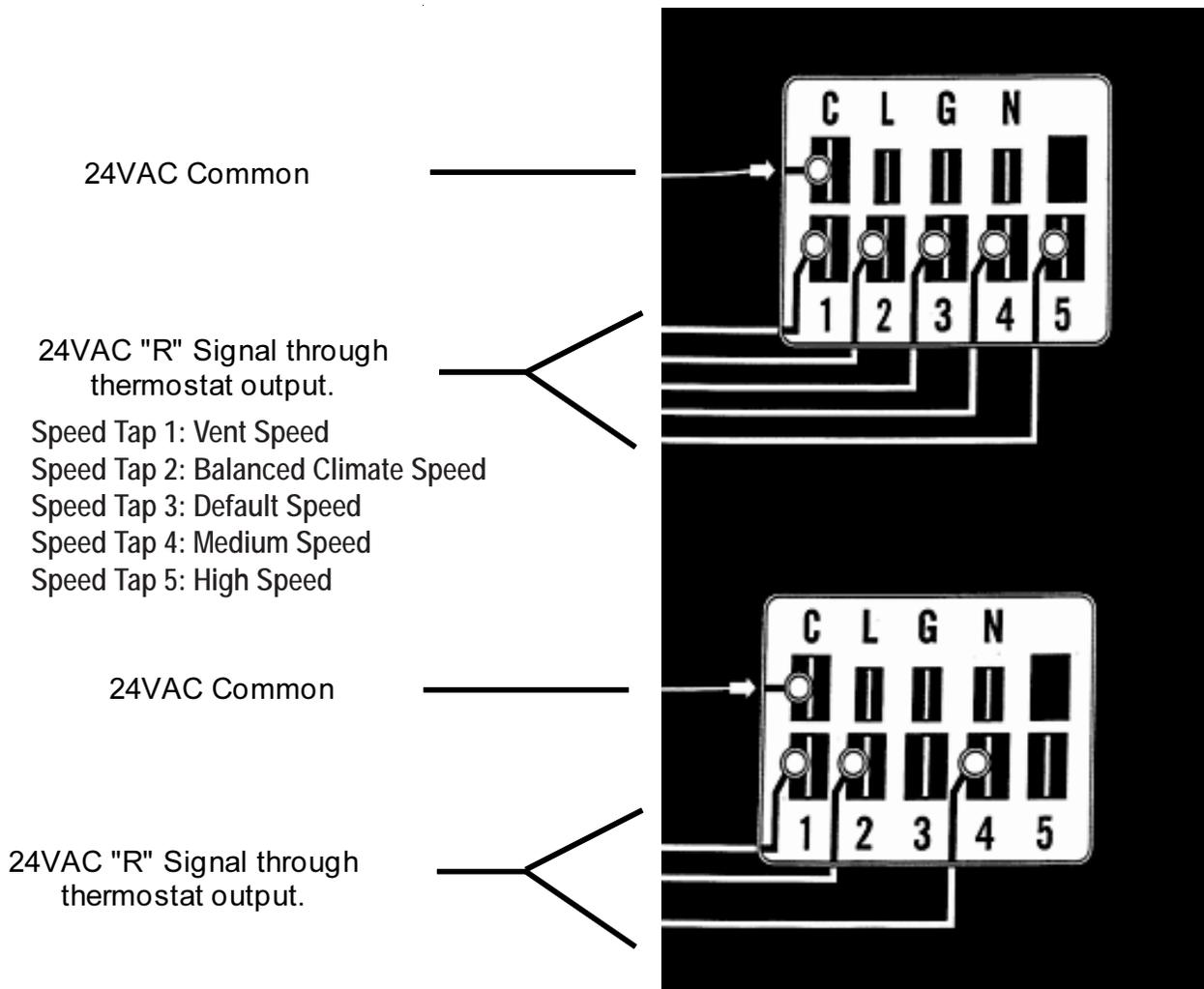

Fan Blade Setting Dimensions

Shown in Figure 13 is the correct fan blade setting for proper air delivery across the outdoor coil. Refer to Table 9 for unit specific dimension.

Any service work requiring removal or adjustment in the fan and/or motor area will require that the dimensions below be checked and blade adjusted in or out on the motor shaft accordingly.

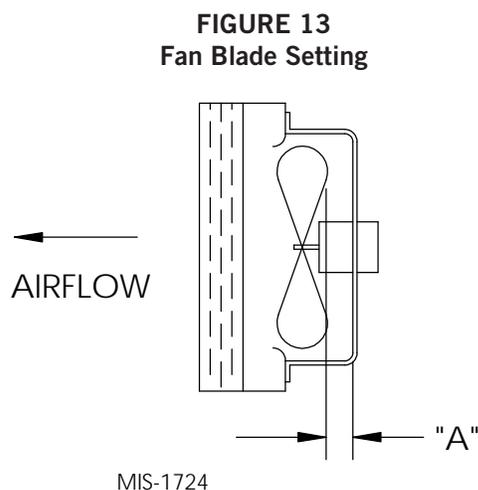

TABLE 9
Fan Blade Dimensions

Model	Dimension A
W18AB/W18LB W24AB/W24LB	1.00"
W30AB/W30LB W36AB/W36LB	1.25"

R-410A Refrigerant Charge

This unit was charged at the factory with the quantity of refrigerant listed on the serial plate. AHRI capacity and efficiency ratings were determined by testing with this refrigerant charge quantity.

The following pressure table shows nominal pressures for the units. Since many installation specific situations can affect the pressure readings, this information should only be used by certified technicians as a guide for evaluating proper system performance. They shall not be used to adjust charge. If charge is in doubt, reclaim, evacuate and recharge the unit to the serial plate charge.

Removal of Fan Shroud

1. Disconnect all power to the unit.
2. Remove the screws holding both grilles, one on each side of unit, and remove grilles.
3. Remove nine screws holding fan shroud to condenser and bottom.
4. Unwire condenser fan motor.
5. Slide complete motor, fan blade and shroud assembly out the left side of the unit.
6. Service motor/fan as needed.
7. Reverse steps to reinstall.

TABLE 10
Cooling Pressure – Standard Airflow

Air Temperature Entering Outdoor Coil °F

Model	Return Air Temp (DB/WB)	Pressure	75	80	85	90	95	100	105	110	115	120	125	131
W18A/L	75/62	Low Side	120	122	126	129	132	134	137	138	139	141	142	144
		High Side	296	318	340	364	388	413	440	466	494	524	553	590
	80/67	Low Side	128	131	135	138	141	143	146	148	149	151	152	154
		High Side	304	326	349	373	398	424	451	478	507	537	567	605
	85/72	Low Side	132	136	140	143	146	148	151	153	154	156	157	159
		High Side	315	337	361	386	412	439	467	495	525	556	587	626
W24A/L	75/62	Low Side	123	125	127	129	132	134	136	137	139	141	143	146
		High Side	302	323	344	367	391	415	441	467	494	523	552	589
	80/67	Low Side	132	134	136	138	141	143	145	147	149	151	153	156
		High Side	310	331	353	376	401	426	452	479	507	536	566	604
	85/72	Low Side	137	139	141	143	146	148	150	152	154	156	158	161
		High Side	321	343	365	389	415	441	468	496	525	555	586	625
W30A/L	75/62	Low Side	122	124	126	129	131	133	135	137	138	140	142	143
		High Side	317	337	360	383	409	435	462	490	520	551	583	622
	80/67	Low Side	130	133	135	138	140	142	144	146	148	150	152	153
		High Side	325	346	369	393	419	446	474	503	533	565	598	638
	85/72	Low Side	135	138	140	143	145	147	149	151	153	155	157	--*
		High Side	336	358	382	407	434	462	491	521	552	585	619	--*
W36A/L	75/62	Low Side	128	130	132	133	135	137	138	140	142	144	146	148
		High Side	318	339	362	385	410	436	463	491	521	552	583	623
	80/67	Low Side	137	139	141	142	144	146	148	150	152	154	156	158
		High Side	326	348	371	395	421	447	475	504	534	566	598	639
	85/72	Low Side	142	144	146	147	149	151	153	155	157	159	161	--*
		High Side	337	360	384	409	436	463	492	522	553	586	619	--*

Low side pressure ± 4 PSIG
High side pressure ± 10 PSIG

Tables are based upon rated CFM (airflow) across the evaporator coil. If there is any doubt as to correct operating charge being in the system, the charge should be removed and system evacuated and recharged to serial plate charge weight.

NOTE: Pressure table based on high speed condenser fan operation. If condensing pressures appear elevated check condenser fan wiring. See **Condenser Fan Operation** on page 22.

* Operating at these conditions would be outside the compressor operating envelope and is not recommended.

TABLE 11
Cooling Pressure – Balanced Climate Airflow

Air Temperature Entering Outdoor Coil °F

Model	Return Air Temp (DB/WB)	Pressure	75	80	85	90	95	100	105	110	115	120	125	131
W18A/L	75/62	Low Side	117	119	121	122	124	126	129	131	133	135	137	139
		High Side	295	317	338	362	385	410	436	463	491	520	550	587
	80/67	Low Side	125	127	129	131	133	135	138	140	142	144	146	149
		High Side	303	325	347	371	395	421	447	475	504	533	564	602
	85/72	Low Side	129	131	134	136	138	140	143	145	147	149	151	154
		High Side	314	336	359	384	409	436	463	492	522	552	584	623
W24A/L	75/62	Low Side	116	118	120	122	123	125	128	130	132	135	137	139
		High Side	296	318	339	362	385	410	434	460	488	515	544	579
	80/67	Low Side	124	126	128	130	132	134	137	139	141	144	146	149
		High Side	304	326	348	371	395	420	445	472	500	528	558	594
	85/72	Low Side	128	130	132	135	137	139	142	144	146	149	151	154
		High Side	315	337	360	384	409	435	461	489	518	546	578	615
W30A/L	75/62	Low Side	117	120	122	124	126	128	130	132	134	135	137	138
		High Side	312	334	357	381	406	432	458	486	514	543	572	609
	80/67	Low Side	125	128	130	133	135	137	139	141	143	144	146	148
		High Side	320	343	366	391	416	443	470	498	527	557	587	625
	85/72	Low Side	129	132	135	138	140	142	144	146	148	149	151	153
		High Side	331	355	379	405	431	459	486	515	545	576	608	647
W36A/L	75/62	Low Side	120	122	123	124	126	128	130	132	135	137	138	141
		High Side	312	332	354	377	402	427	454	483	513	543	576	616
	80/67	Low Side	128	130	132	133	135	137	139	141	144	146	148	151
		High Side	320	341	363	387	412	438	466	495	526	557	591	632
	85/72	Low Side	132	135	137	138	140	142	144	146	149	151	153	156
		High Side	331	353	376	401	426	453	482	512	544	576	612	654

Low side pressure ± 4 PSIG

High side pressure ± 10 PSIG

Tables are based upon Balanced Climate CFM (airflow) across the evaporator coil. If there is any doubt as to correct operating charge being in the system, the charge should be removed and system evacuated and recharged to serial plate charge weight.

NOTE: Pressure table based on high speed condenser fan operation. If condensing pressures appear elevated check condenser fan wiring. See **Condenser Fan Operation** on page 22.

TABLE 12
Electrical Specifications – WAB Series**

Model	Rated Volts & Phase	No. Field Power Circuits	Single Circuit				Multiple Circuit											
			① Minimum Circuit Ampacity	② Maximum External Fuse or Ckt. Brkr.	③ Field Power Wire Size	④ Ground Wire	① Minimum Circuit Ampacity		② Maximum External Fuse or Ckt. Breaker		③ Field Power Wire Size		④ Ground Wire Size					
							Ckt. A	Ckt. B	Ckt. A	Ckt. B	Ckt. A	Ckt. B	Ckt. A	Ckt. B				
W18AB-A00, A0Z A05 A08 A10	230/208-1	1	16	20	12	12												
		1	30	30	10	10												
		1	45	45	8	10												
		1	56	60	6	10												
W24AB-A00, A0Z A05 A08 A10	230/208-1	1	21	25	10	10												
		1	30	30	10	10												
		1	46	50	8	10												
		1	57	60	6	10												
W24AB-B00, B0Z B06	230/208-3	1	15	20	12	12												
		1	23	25	10	10												
W24AB-C00, C0Z C06	460-3	1	8	15	14	14												
		1	12	15	14	14												
W30AB-A00, A0Z A05 A08 A10 A15	230/208-1	1	23	35	8	10												
		1	31	35	8	10												
		1	47	50	8	10												
		1	57	60	6	10												
		1 or 2	83	90	4	8	57	26	60	30	6	10	10	10				
W30AB-B00, B0Z B06 B09 B15	230/208-3	1	17	20	12	12												
		1	23	25	10	10												
		1	32	35	8	10												
		1	50	50	8	10												
W30AB-C00, C0Z C06 C09 C12 C15	460-3	1	9	15	14	14												
		1	12	15	14	14												
		1	16	20	12	12												
		1	21	25	10	10												
		1	25	25	10	10												
W36AB-A00, A0Z A05 A08 A10 A15	230/208-1	1	27	35	8	10												
		1	32	35	8	10												
		1	48	50	8	10												
		1	58	60	6	10												
		1 or 2	84	90	4	8	58	26	60	30	6	10	10	10				
W36AB-B00, B0Z B06 B09 B15	230/208-3	1	20	25	10	10												
		1	24	25	10	10												
		1	33	35	8	10												
		1	51	60	6	10												
W36AB-C00, C0Z C06 C09 C15	460-3	1	11	15	14	14												
		1	12	15	14	14												
		1	17	20	14	14												
		1	26	30	12	12												

- ① These "Minimum Circuit Ampacity" values are to be used for sizing the field power conductors. Refer to the National Electrical code (latest version), Article 310 for power conductor sizing. **CAUTION:** When more than one field power circuit is run through one conduit, the conductors must be derated. Pay special attention to note 8 of Table 310 regarding Ampacity Adjustment Factors when more than three (3) current carrying conductors are in a raceway.
- ② Maximum size of the time delay fuse or circuit breaker for protection of field wiring conductors.
- ③ Based on 75°copper wire. All wiring must conform to the National Electrical Code and all local codes.

NOTE: The Maximum Overcurrent Protection (MOCP) value listed is the maximum value as per UL 1995 calculations for MOCP (branch-circuit conductor sizes in this chart are based on this MOCP). The actual factory-installed overcurrent protective device (circuit breaker) in this model may be lower than the maximum UL 1995 allowable MOCP value, but still above the UL 1995 minimum calculated value or Minimum Circuit Ampacity (MCA) listed.

IMPORTANT: While this electrical data is presented as a guide, it is important to electrically connect properly sized fuses and conductor wires in accordance with the National Electrical Code and all local codes.

TABLE 13
Electrical Specifications – WLB Series**

Model	Rated Volts & Phase	No. Field Power Circuits	Single Circuit				Multiple Circuit							
			① Minimum Circuit Ampacity	② Maximum External Fuse or Ckt. Brkr.	③ Field Power Wire Size	④ Ground Wire	① Minimum Circuit Ampacity		② Maximum External Fuse or Ckt. Breaker		③ Field Power Wire Size		④ Ground Wire Size	
							Ckt. A	Ckt. B	Ckt. A	Ckt. B	Ckt. A	Ckt. B	Ckt. A	Ckt. B
W18LB-A00, A0Z A05 A08 A10	230/208-1	1	16	20	12	12								
		1	30	30	10	10								
		1	46	50	8	10								
		1	56	60	6	10								
W24LB-A00, A0Z A05 A08 A10	230/208-1	1	21	25	10	10								
		1	30	35	8	10								
		1	46	50	8	10								
		1	57	60	6	10								
W24LB-B00, B0Z B06	230/208-3	1	15	20	12	14								
		1	23	25	10	10								
W30LB-A00, A0Z A05 A08 A10 A15	230/208-1	1	23	35	8	10								
		1	31	35	8	10								
		1	46	50	8	10								
		1	57	60	6	10								
		1 or 2	83	90	4	8	57	26	60	30	6	10	10	10
W30LB-B00, B0Z B09 B15	230/208-3	1	17	20	12	12								
		1	32	35	8	10								
		1	50	50	8	10								
W30LB-C00, C0Z C09 C15	460-3	1	9	15	14	14								
		1	16	20	12	12								
		1	26	30	10	10								
W36LB-A00, A0Z A05 A10 A15	230/208-1	1	27	35	8	10								
		1	32	35	8	10								
		1	58	60	6	10								
		1 or 2	84	90	4	8	58	26	60	30	6	10	10	10
W36LB-B00, B0Z B09 B15	230/208-3	1	20	25	10	10								
		1	33	35	8	10								
		1	51	60	6	10								
W36LB-C00, C0Z C09 C15	460-3	1	9	15	14	14								
		1	15	15	14	14								
		1	24	25	10	10								

① These "Minimum Circuit Ampacity" values are to be used for sizing the field power conductors. Refer to the National Electrical code (latest version), Article 310 for power conductor sizing. **CAUTION:** When more than one field power circuit is run through one conduit, the conductors must be derated. Pay special attention to note 8 of Table 310 regarding Ampacity Adjustment Factors when more than three (3) current carrying conductors are in a raceway.

② Maximum size of the time delay fuse or circuit breaker for protection of field wiring conductors.

③ Based on 75°C copper wire. All wiring must conform to the National Electrical Code and all local codes.

NOTE: The Maximum Overcurrent Protection (MOCP) value listed is the maximum value as per UL 1995 calculations for MOCP (branch-circuit conductor sizes in this chart are based on this MOCP). The actual factory-installed overcurrent protective device (circuit breaker) in this model may be lower than the maximum UL 1995 allowable MOCP value, but still above the UL 1995 minimum calculated value or Minimum Circuit Ampacity (MCA) listed.

IMPORTANT: While this electrical data is presented as a guide, it is important to electrically connect properly sized fuses and conductor wires in accordance with the National Electrical Code and all local codes.

Setting Unit Airflow

The unit is set from the factory at the default speed. Most units have three selectable cooling speed taps that can be utilized. The default speed is the lowest cooling speed. The two higher speed taps can be used for higher duct static applications so that the unit can maintain the recommended airflow as shown in Table 14. The higher speeds can also be used when higher sensible cooling is desired. To change to the higher speed taps, move the orange/black wire on the blower speed terminal block to either MED or HI. Refer to Table 16 on page 36 for the corresponding airflow of each tap. Set the unit duct static based on the highest airflow that the unit will run at.

NOTE: Be sure to adjust the system static or blower speed to maintain airflows above the minimum recommendations to prevent freeze up conditions if Balanced Climate mode is activated.

Do not operate the unit in Balanced Climate mode if running high static applications as indicated in the blower performance table. If Balanced Climate mode is activated as described on page 17, the unit will run in this mode at all times unless there is a call for ventilation, electric heat or 2nd stage cooling from a 2-stage thermostat. At that time, the unit will automatically activate a higher speed tap.

Blower Speeds

Five factory programmed speed taps (torque settings) are available for the motor, and are selected through different unit modes of operation. These modes are energized by 24VAC signals from the low voltage terminal block located inside the control panel by a thermostat or other controlling device. Each speed tap is programmed by Bard at the factory to different motor torque settings (see Figure 14).

FIGURE 14
Speed Taps

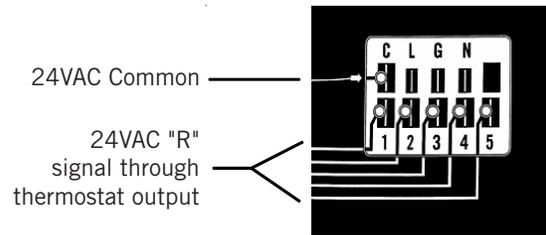

- Speed Tap 1: Vent Speed
- Speed Tap 2: Balanced Climate Speed
- Speed Tap 3: Default Speed
- Speed Tap 4: Medium Speed
- Speed Tap 5: High Speed

Multiple motor speed taps may be energized simultaneously by 24VAC power during different modes of operation. The highest number speed tap energized takes priority with 5 being the highest and 1 being the lowest. See Table 15 for the corresponding blower speeds with the different modes of operation.

Programmed blower speed taps are as follows (see also Figure 15):

Speed Tap 1: **Vent/blower only** speed

Speed Tap 2: **Balanced Climate** speed

Speed Tap 3: **Default LO cooling & heating** speed. Energized by default for cooling operation through the blower speed tap selection and is labeled as LO.

Speed Tap 4: **Optional MED Cooling & heating** speed. Selected manually through the blower speed tap selection and is labeled as MED.

Speed Tap 5: **Optional HI cooling & heating** speed. Selected manually through the blower speed tap selection and is labeled as HI.

TABLE 14
Recommended Airflow

Model	Nominal Rated CFM*	Nominal Rated ESP*	Recommended Airflow Range	Factory Speed Connection
W18A W18L	600	.10	550 - 725	Default
W24A W24L	800	.10	700 - 950	
W30A W30L	950	.15	900 - 1125	
W36A W36L	1150	.15	1000 - 1200	

* Rated CFM and ESP on factory speed connection.

TABLE 15
Blower Speeds for Unit Operational Modes

Unit Operation	Thermostat Inputs – 24VAC							Speed Taps			Blower Speed	Compressor Operation
	G	Y1	Y2	W1	W2	A	D	1	2	3-4-5 ¹		
Blower Only	X							X			Vent/Blower Only	Off
Balanced Climate Cooling	X	X						X	X		Balanced Climate	On
Full Load Cool	X	X	X					X	X	X	Lo/Med/Hi	On
1st Stage Heat				X						X	Lo/Med/Hi	Off
2nd Stage Heat				X	X					X	Lo/Med/Hi	Off
Dehumidify ²							X	X	X		Balanced Climate	On

¹ Fan speed is selectable through the blower speed control terminal block. LO (default), MED or HI speeds can be used.

² Dehumidification operation is disabled when a call for heating or cooling occurs. Unit runs at Balanced Climate speed during dehumidification operation.

FIGURE 15
Speed Taps

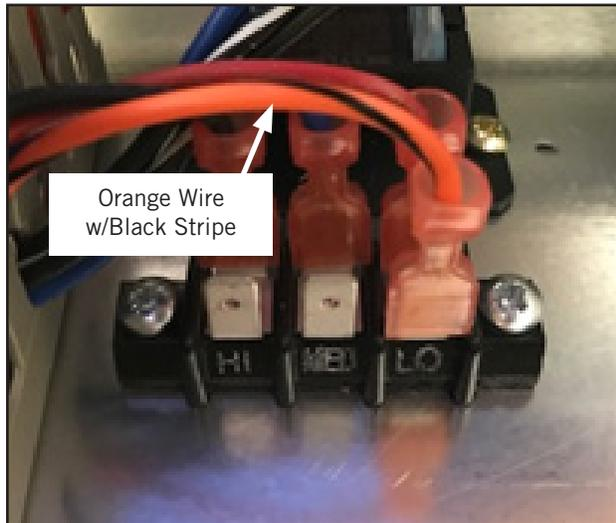

Speed Tap 1 – Vent/Blower Only

Speed taps 1 and 3 are programmed to identical torque settings in the ECM motor. This means that if speed tap 1 is energized, the airflow amount will be the same as default airflow. Tap 1 is used when a vent is installed and ventilation is called for by energizing the A terminal of the low voltage terminal block with 24VAC. Speed tap 1 is the lowest priority; if any of the other speed taps are energized, they will override speed tap 1.

Speed Tap 2 – Balanced Climate

Speed tap 2 is programmed to a lower than rated speed in the ECM motor. In order for Balanced Climate speed to be used during compressor cooling mode, the jumper between Y1 and Y2 must be removed. This

means that if speed tap 2 is energized, the airflow amount will be lower than default airflow. Tap 2 is used when Balanced Climate is called for by energizing the Y1 terminal of the low voltage terminal block with 24VAC. Speed tap 2 is overridden if taps 3, 4, or 5 are energized.

Speed Tap 3 – Default LO Cooling & Heating

Speed tap 3 is programmed for rated speed in the SelecTech motor. This means that if speed tap 3 is energized, the airflow amount will be the default airflow. Tap 3 is used by default when cooling is called for by energizing the Y1 terminal of the low voltage terminal block with 24VAC. The unit is shipped with the jumper between Y1 and Y2 installed and it must be removed to use Balanced Climate mode. The unit is shipped with the orange/black wire connected to terminal LO (rated speed) on the blower selection speed terminal block. Speed tap 3 can be overridden if taps 4 or 5 are energized by changing the position of the orange/black wire on the blower selection speed terminal block to MED (4) or HI (5) positions.

Speed Tap 4 – Optional MED Cooling & Heating

Speed tap 4 is programmed to a higher than rated speed in the ECM motor. This is a user-selectable airflow amount that will be higher than rated airflow. Tap 4 is used for cooling operation if the orange/black wire on the blower speed selection terminal block is moved to MED. Speed tap 4 can be overridden if tap 5 is energized.

Speed Tap 5 – Optional HI Cooling & Heating

Speed tap 5 is programmed to the highest speed in the ECM motor. This is a user-selectable airflow amount that will provide the highest rated airflow. Tap 5 is used for cooling operation if the orange/black wire on the blower speed selection terminal block is moved to HI.

Dirty Filter Switch

1. Disconnect all power to the unit. Remove control panel outer cover and upper front panel.
2. The dirty filter switch is located on top of the filter partition to the right of the blower wheels on W**AB units and to the left of the blower wheels on W**LB units (see Figure 16). The dirty filter indicator light and reset switch is attached to the side of the control panel on the right side of the filter access opening on W**AB units and on the left side of the filter access opening on W**LB units. Remove the cover on the dirty filter switch and ensure the knob is set at 0.4" W.C. (see Figure 17). This is only a recommended starting point prior to making switch adjustments. Switch setting is highly dependent on filter type used, blower speed, unit ducting and other unit installation characteristics. See **Dirty Filter Switch Adjustment** for instructions on how to make proper switch adjustments.
3. Re-install upper front panel.

Dirty Filter Switch Adjustment

1. Apply power to the unit.
2. Turn the unit indoor blower on (energize R-G on low voltage terminal board).
3. With air filters installed and switch initially set at 0.4" W.C. (see Step 2 under **Dirty Filter Switch**), begin restricting the air filter of the unit using a piece of cardboard under the filters until the switch trips and the light comes on. If the filter is restricted by 75% (or desired restriction amount), skip to Step 6.
4. If switch setting adjustment is required, disconnect power to the unit. Remove the upper front panel and the cover on the airflow switch so that adjustment can be made. If the switch tripped before 75% restriction was reached, turn the knob slightly clockwise. If the switch tripped after 75%, turn the knob counter-clockwise (see Figure 17).
5. Replace the upper front panel and repeat Steps 1-3. Continue to make adjustments described in Step 4 until the desired restriction is obtained.
6. Remove the restriction and reset the filter switch. Replace the switch cover once adjustment is complete.
7. Install the outer control panel cover. This completes the adjustment.

FIGURE 16
Dirty Filter Switch Location

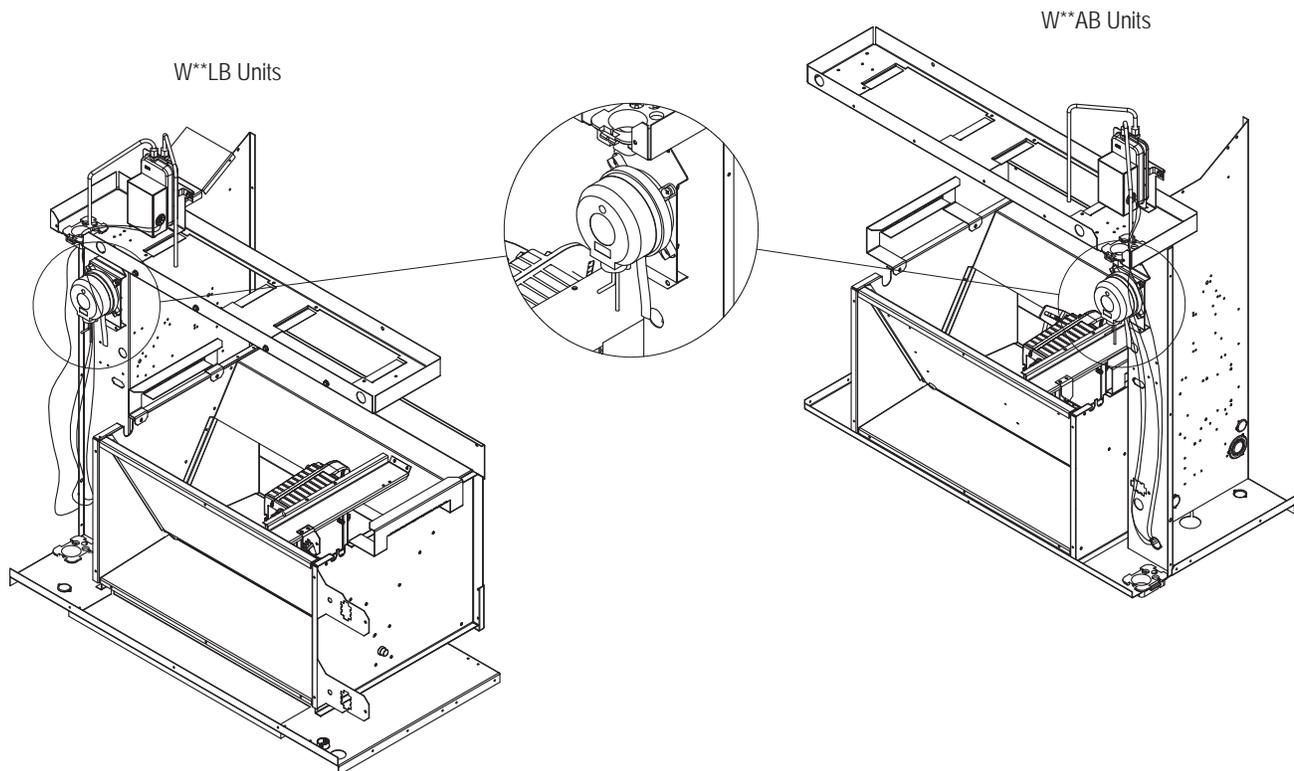

FIGURE 17
Adjusting Dirty Filter Switch

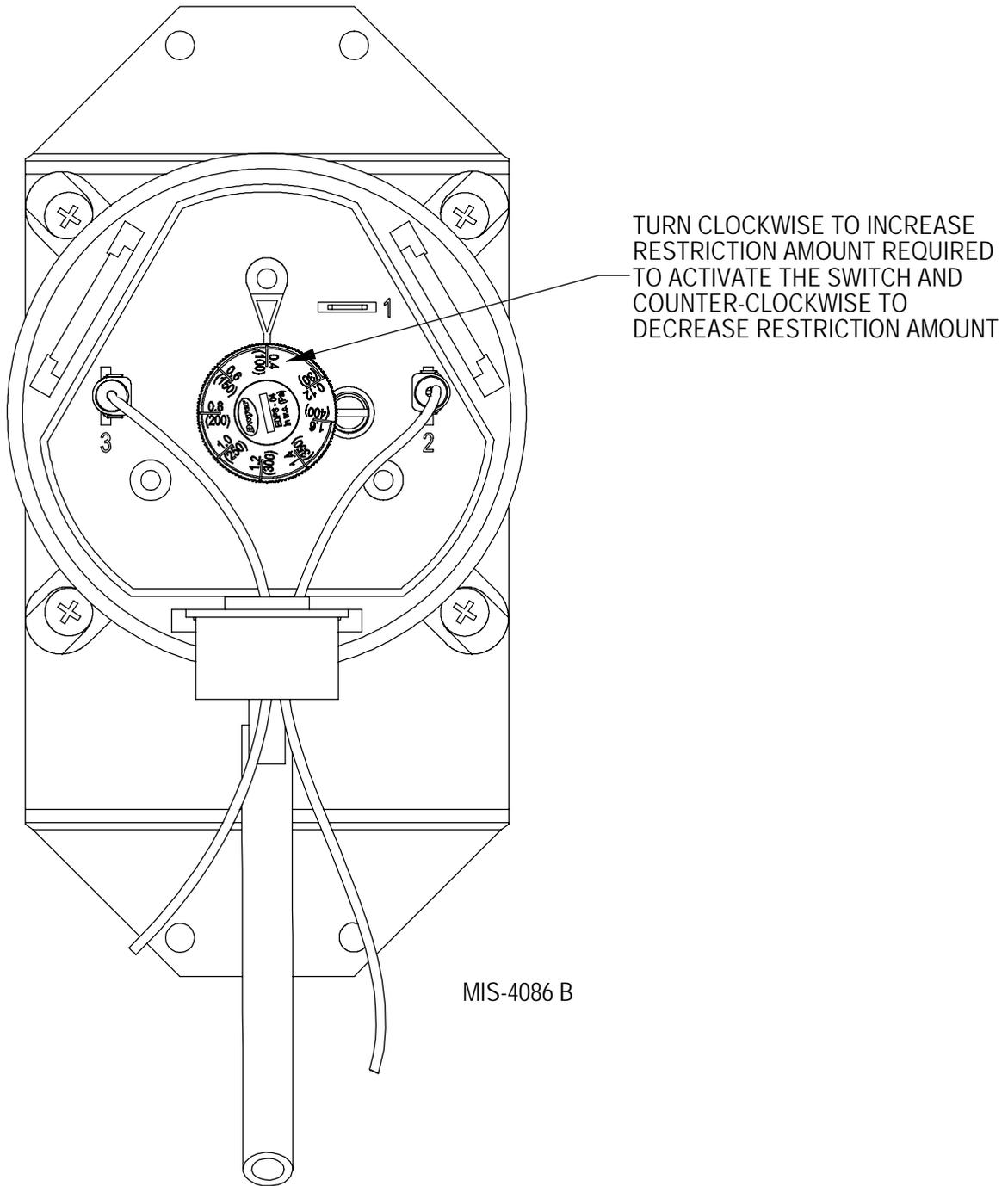

TABLE 16
Indoor Blower Performance

	E.S.P. ¹ (In. H ₂ O)	Balanced Climate™ Speed		Default LO Cooling & Heating/ Ventilation Speed ²		Optional MED Cooling & Heating Speed		Optional HI Cooling & Heating Speed	
		Dry Coil	Wet Coil	Dry Coil	Wet Coil	Dry Coil	Wet Coil	Dry Coil	Wet Coil
W18AB/W18LB	0.00	520	510	680	665	Dedicated electric heat speed (same airflows as W24AB/LB default airflows)		865	855
	0.10	435	420	615	600			810	800
	0.15	395	380	585	565			785	770
	0.20			555	535			760	745
	0.25			525	510			735	720
	0.30			495	480			710	695
	0.40			440	425			665	650
	0.50			385	375			620	605
W24AB/W24LB	0.00	630	625	890	835	1005	980	1025	1035
	0.10	580	565	825	800	960	930	990	980
	0.15	550	535	795	780	935	910	975	955
	0.20	525	500	770	755	910	885	955	930
	0.25			740	730	890	865	935	910
	0.30			715	705	870	840	915	885
	0.40			670	650	825	805	870	845
	0.50			630	585	785	765	825	805
W30AB/W30LB	0.00			830	825	1050	1020	1170	1135
	0.10	765	745	1000	975	1120	1105	1170	1155
	0.15	730	705	975	950	1095	1085	1150	1130
	0.20	700	670	950	925	1070	1060	1130	1105
	0.25			920	900	1050	1040	1110	1080
	0.30			890	870	1025	1015	1085	1055
	0.40			830	815	975	955	1040	1000
	0.50			770	755	930	890	985	945
W36AB/W36LB	0.00			925	900	1255	1225	1365	1345
	0.10	850	825	1205	1175	1320	1300	1445	1425
	0.15	815	790	1180	1150	1295	1275	1415	1395
	0.20	780	755	1155	1125	1275	1250	1385	1360
	0.25			1130	1100	1250	1220	1350	1320
	0.30			1100	1070	1225	1195	1310	1280
	0.40			1050	1015	1180	1140	1225	1185
	0.50			1000	960	1130	1075	1130	1075

¹ E.S.P. is the total combined external static pressure of both the supply and return ducts or grills.

² This is the speed set at the factory.

TABLE 17
Maximum ESP of Operation
Electric Heat Only

Model	W18A/L, W24A/L	W30A/L, W36A/L	
Outlet	FRONT	FRONT	
Speed	Single	High	Low
-A0Z	.50	.50	.50
-A05	.50	.50	.50
-A08	.50	.50	.50
-A10	.30	.40	.35
-A15		.40	.35
-B0Z	.50	.50	.50
-B06	.40	.50	.40
-B09		.50	.50
-B15		.35	.30
-C0Z	.50	.50	.50
-C06	.50	.50	.50
-C09		.50	.40
-C15		.45	.35

Values shown are for units equipped with standard 1" throwaway filter or 1" washable filter.

Derate ESP by .15 for 2" pleated filters.

TABLE 18
Electric Heat

Models	240V-1		208V-1		240V-3		208V-3		460V-3		
	KW	Amps	BTUH	Amps	BTUH	Amps	BTUH	Amps	BTUH	Amps	BTUH
5		20.8	17065	18.1	12800						
6						14.4	20500	12.5	15360	7.2	20500
8		33.3	27300	28.8	20475						
9						21.7	30600	18.7	23030	10.8	30700
10		41.6	34130	36.2	25600						
15		62.5	51250	54.0	38400	36.2	51200	31.2	38400	18.0	51200

TABLE 19
Vent and Control Options

Part Number	Description	W18, W24	W30, W36
CMA-14	ODT	X	X
CMC-15	Start Kit (230V 1-Phase)	X	X
CMC-31	Dirty Filter Sensor Kit	X	X
CMC-34	Alarm Relay	X	X
CMC-36	Crankcase Heater (230V)	X	X
CMC-37	Crankcase Heater (460V)	X	X
CMA-37	LAC - Modulating (230V)	X	
CMA-38	LAC - Modulating (460V)	X	
CMA-39	LAC - On/Off		X
CMA-40	DDC	X	X
BOP2	Blank Off Plate	X	
FAD-NE2	Fresh Air Damper - No Exhaust	X	
FAD-BE2	Fresh Air Damper - Barometric Exhaust	X	
CRV-F2-*	Commercial Ventilator - On/Off, Spring Return	X	
CRV-V2-*	Commercial Ventilator - 0-10V, Spring Return	X	
ECON-NC2-*	Economizer - Bldg. Equipment, 0-10V, No Controls	X	
ECON-S2-*	Economizer - School	X	
ECON-WD2-*	Economizer - Bldg. Equipment, Enthalpy	X	
ECON-DB2-*	Economizer - Bldg. Equipment, Temperature	X	
ERV-FA2-*	Energy Recovery Ventilator (230V)	X	
ERV-FC2-*	Energy Recovery Ventilator (460V)	X	
BOP3	Blank Off Plate		X
FAD-NE3	Fresh Air Damper - No Exhaust		X
FAD-BE3	Fresh Air Damper - Barometric Exhaust		X
CRV-F3-*	Commercial Ventilator - On/Off, Spring Return		X
CRV-V3-*	Commercial Ventilator - 0-10V, Spring Return		X
ECON-NC3-*	Economizer - Bldg. Equipment, 0-10V, No Controls		X
ECON-S3-*	Economizer - School		X
ECON-WD3-*	Economizer - Bldg. Equipment, Enthalpy		X
ECON-DB3-*	Economizer - Bldg. Equipment, Temperature		X
ERV-FA3-*	Energy Recovery Ventilator (230V)		X
ERV-FC3-*	Energy Recovery Ventilator (460V)		X

* Insert color to match unit (X = Beige, 1 = White, 4 = Buckeye Gray, 5 = Desert Brown, 8 = Dark Bronze, S = Stainless, A = Aluminum)

TABLE 20A
Optional Accessories – Right Hand

		W18AB-A	W24AB-A	W24AB-B	W24AB-C	W30AB-A	W30AB-B	W30AB-C	W36AB-A	W36AB-B	W36AB-C
Heater Kits	EHW1TAB-A05	X									
	EHW1TAB-A08	X									
	EHW2TAB-A05		X								
	EHW2TAB-A08		X								
	EHW2TA-A10	X	X								
	EHW2TA-B06			X							
	EHWH24B-C06				X						
	EHW3TA-A05					X			X		
	EHW3TA-A08					X			X		
	EHW3TA-A10					X					
	EHW3TAB-A10								X		
	EHW3TA-A15								X		
	EHW3TAB-A15					X					
	EHW30A-B06						X				
	EHW3TA-B06									X	
	EHW3TA-B09						X				
	EHW3TAB-B09									X	
	EHW3TA-B15									X	
	EHW3TAB-B15						X				
	EHW3TA-C06							X			X
	EHW3TA-C09							X			X
	EHW3TA-C12							X			
	EHW3TA-C15										X
EHW3TAB-C15							X				
Circuit Breaker (WMCB) and Pull Disconnect (WMPD)	WMCB-02A	X									
	WMCB-02B			X			X				
	WMCB-03A		X								
	WMCB-03B									X	
	WMCB-05A					X			X		
	WMPD-01C				X			X			X

TABLE 20B
Optional Accessories – Left Hand

		W18LB-A	W24LB-A	W24LB-B	W30LB-A	W30LB-B	W30LB-C	W36LB-A	W36LB-B	W36LB-C
Heater Kits	EHW1TAB-A05L	X								
	EHW1TAB-A08L	X								
	EHW2TAB-A05L		X							
	EHW2TAB-A08L		X							
	EHW2TA-A10L	X	X							
	EHW2TA-B06L			X						
	EHW3TA-A05L				X			X		
	EHW3TA-A08L				X					
	EHW3TA-A10L				X					
	EHW3TAB-A10L							X		
	EHW3TA-A15L				X			X		
	EHW3TA-B09L					X				
	EHW3TAB-B09L								X	
	EHW3TA-B15L								X	
	EHW3TAB-B15L					X				
	EHW3TA-C09L						X			X
	EHW3TA-C15L									X
EHW3TAB-C15L						X				
Circuit Breaker (WMCB) and Pull Disconnect (WMPD)	WMCB-02AL	X								
	WMCB-02BL			X		X				
	WMCB-03AL		X							
	WMCB-03BL								X	
	WMCB-05AL				X			X		
	WMPD-01CL						X			X

GRAPH 1
W18*B FAD-NE2, 3 W/O Exhaust Ventilation Delivery

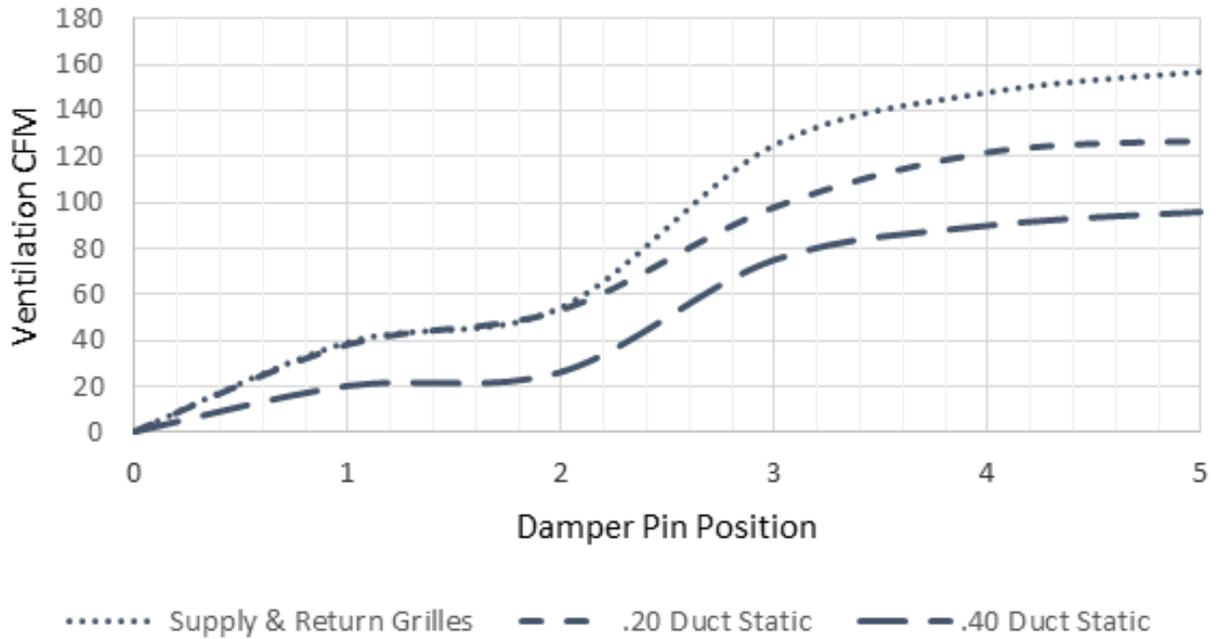

GRAPH 2
W24*B FAD-NE2, 3 W/O Exhaust Ventilation Delivery



GRAPH 3
W30*B FAD-NE2, 3 W/O Exhaust Ventilation Delivery

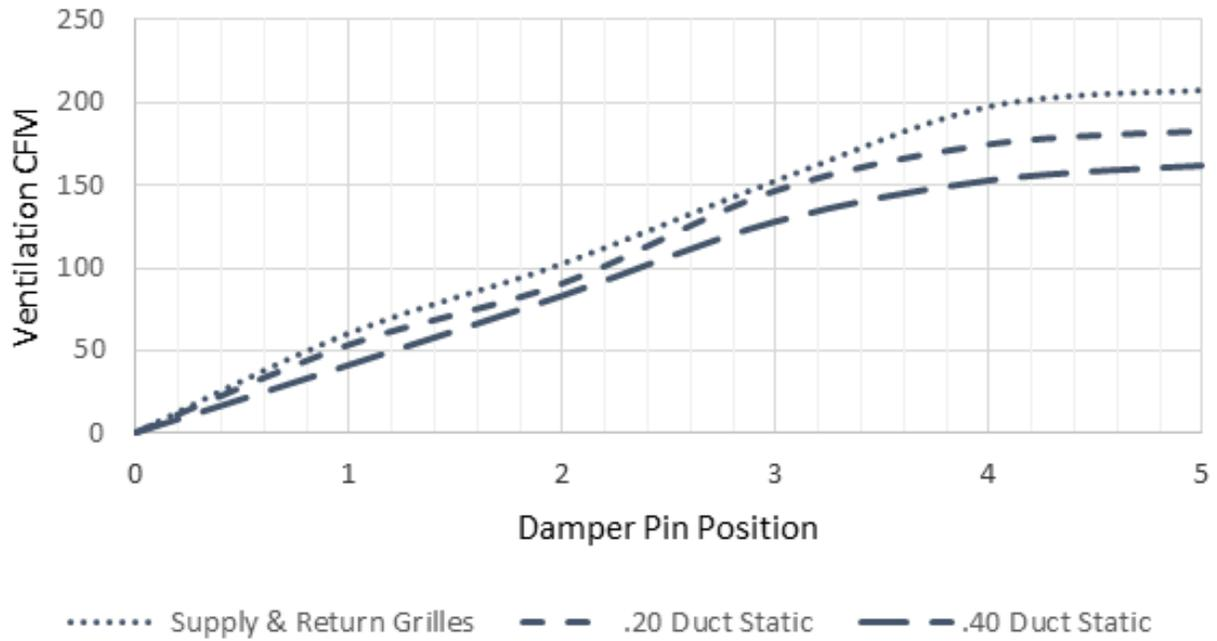

GRAPH 4
W36*B FAD-NE2, 3 W/O Exhaust Ventilation Delivery

