INSTALLATION INSTRUCTIONS

11EER WA SERIES WALL MOUNT AIR CONDITIONER

Models:

W18AB-A	W30AB-D	W18LB-A	W30LB-C	W30ABDA
W24AB-A	W30AB-F	W24LB-A	W30LB-F	W30ABDB
W24AB-B	W36AB-A	W24LB-B	W36LB-A	W30ABDC
W24AB-C	W36AB-B	W24LB-F	W36LB-B	W36ABDA
W24AB-D	W36AB-C	W30LB-A	W36LB-C	W36ABDB
W24AB-F	W36AB-D	W30LB-B	W36LB-F	W36ABDC
W30AB-A	W36AB-E			
W30AB-B	W36AB-F			
W30AB-C				



Bard Manufacturing Company, Inc.
Bryan, Ohio 43506
www.bardhvac.com

Manual: 2100-689
Supersedes: **NEW**
Date: 3-1-19

Climate Control Solutions

CONTENTS

Getting Other Information and Publications 3

Wall Mount General Information 4

Air Conditioner Wall Mount Model Nomenclature	4
Shipping Damage	4
General	4
Duct Work	5
Filters	5
Fresh Air Intake	5
Condensate Drain	5

Installation 6

Wall Mounting Information	6
Mounting the Unit	6
Wiring – Main Power	13
Wiring – Low Voltage.....	13
Low Voltage Connections	13

Start Up 17

General	17
Topping Off System Charge	17
Safety Practices	17
Important Installer Note.....	17
High Pressure Switch.....	17
Three Phase Scroll Compressor Start Up Information.....	17

Figures

Figure 1 Fresh Air Damper	5
Figure 2 Unit Dimensions	7
Figure 3A Mounting Instructions – W18, 24	8
Figure 3B Mounting Instructions – W30, 36.....	9
Figure 4 Electric Heat Clearance	10
Figure 5 Wall Mounting Instructions	11
Figure 6 Wall Mounting Instructions	11
Figure 7 Common Wall Mounting Installations	12
Figure 8 Programmable Thermostat Connections	15
Figure 9 Thermostat Connections	16
Figure 10 8201-164 Compressor Control Module ...	19
Figure 11 Motor Connections	21
Figure 12 Motor Connections	22
Figure 13 Fan Blade Setting	23

Phase Monitor.....	18
Condenser Fan Operation	18
Service Hints	18
Sequence of Operation.....	18
Balanced Climate™ Mode.....	18
Vent Connection Plug.....	18
Compressor Control Module	19
Features	19
Delay-on-Make Timer	19
Short Cycle/Delay-on-Break	19
Low Pressure Detection.....	19
High Pressure Detection.....	19
Test Mode.....	20
Brownout Protection with Adjustment.....	20
Pressure Service Ports	20

Service 21

Troubleshooting Nidec SelecTech Series ECM Motors.....	21
If the Motor is Running	21
If the Motor is Not Running.....	21
Model SelecTech Communication Diagnostics ...	22
Fan Blade Setting Dimensions.....	23
R-410A Refrigerant Charge	23
Removal of Fan Shroud.....	23
Setting Unit Airflow	27

Tables

Table 1 Clearance Required for Service Access and Adequate Condenser Airflow.....	6
Table 2 Minimum Clearances Required to Combustible Materials.....	6
Table 3 Additional Low Voltage Connections (if applicable).....	13
Table 4 Low Voltage Connections for DDC Control	14
Table 5 Humidity Controls	14
Table 6 CO ₂ Controllers	14
Table 7 Thermostat Wire Size.....	14
Table 8 Wall Thermostats	14
Table 9 Fan Blade Dimensions.....	23
Table 10 Cooling Pressure	24
Table 11 Electrical Specifications W**AB	25
Table 12 Electrical Specifications W**LB	26
Table 13 Recommended Airflow	27
Table 14 Indoor Blower Performance	28
Table 15 Maximum ESP Electric Heat Only.....	29
Table 16 Electric Heat	29
Table 17 Vent and Control Options	30
Table 18A Optional Accessories – Right Hand	31
Table 18B Optional Accessories – Left Hand	32

GETTING OTHER INFORMATION AND PUBLICATIONS

These publications can help when installing the furnace. They can usually be found at the local library or purchased directly from the publisher. Be sure to consult the current edition of each standard.

National Electrical CodeANSI/NFPA 70

Standard for the InstallationANSI/NFPA 90A
of Air Conditioning and Ventilating Systems

Standard for Warm Air.....ANSI/NFPA 90B
Heating and Air Conditioning Systems

Load Calculation for ACCA Manual J
Residential Winter and Summer Air Conditioning

Duct Design for Residential ACCA Manual D
Winter and Summer Air Conditioning and Equipment
Selection

For more information, contact these publishers:

ACCA Air Conditioning Contractors of America
1712 New Hampshire Ave. N.W.
Washington, DC 20009
Telephone: (202) 483-9370
Fax: (202) 234-4721

ANSI American National Standards Institute
11 West Street, 13th Floor
New York, NY 10036
Telephone: (212) 642-4900
Fax: (212) 302-1286

**ASHRAE American Society of Heating, Refrigeration
and Air Conditioning Engineers, Inc.**
1791 Tullie Circle, N.E.
Atlanta, GA 30329-2305
Telephone: (404) 636-8400
Fax: (404) 321-5478

NFPA National Fire Protection Association
Batterymarch Park
P.O. Box 9101
Quincy, MA 02269-9901
Telephone: (800) 344-3555
Fax: (617) 984-7057

WALL MOUNT GENERAL INFORMATION

AIR CONDITIONER WALL MOUNT MODEL NOMENCLATURE

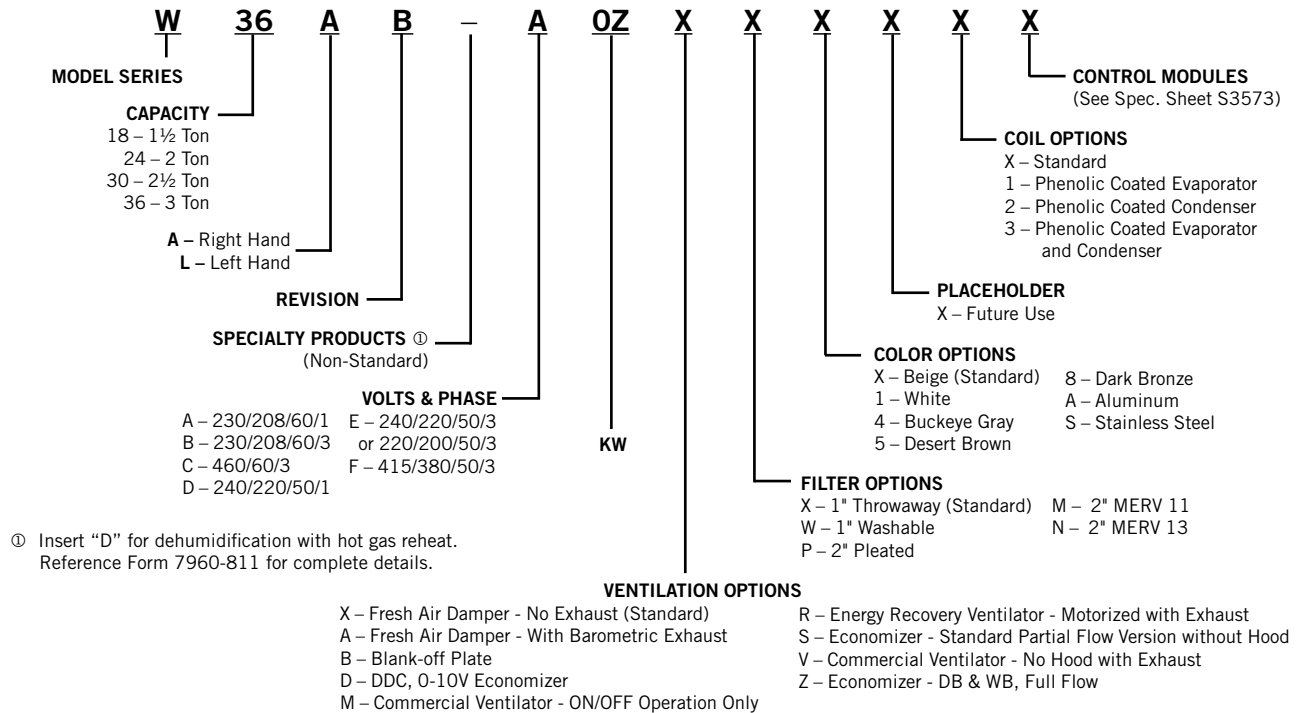

NOTE: Vent options X and B are without exhaust capability. May require separate field-supplied barometric relief in building.

Shipping Damage

Upon receipt of equipment, the carton should be checked for external signs of shipping damage. If damage is found, the receiving party must contact the last carrier immediately, preferably in writing, requesting inspection by the carrier's agent.

General

The equipment covered in this manual is to be installed by trained, experienced service and installation technicians.

This appliance is not intended for use by persons (including children) with reduced physical, sensory or mental capabilities, or lack of experience and knowledge, unless they have been given supervision or instruction concerning use of the appliance by a person responsible for their safety.

Children should be supervised to ensure that they do not play with the appliance.

The refrigerant system is completely assembled and charged. All internal wiring is complete.

The unit is designed for use with or without duct work. Flanges are provided for attaching the supply and return ducts.

These instructions explain the recommended method to install the air cooled self-contained unit and the electrical wiring connections to the unit.

These instructions and any instructions packaged with any separate equipment required to make up the entire air conditioning system should be carefully read before beginning the installation. Note particularly "Starting Procedure" and any tags and/or labels attached to the equipment.

While these instructions are intended as a general recommended guide, they do not supersede any national and/or local codes in any way. Authorities having jurisdiction should be consulted before the installation is made. See page 3 for information on codes and standards.

Size of unit for a proposed installation should be based on heat loss calculation made according to methods of Air Conditioning Contractors of America (ACCA). The air duct should be installed in accordance with the Standards of the National Fire Protection Association for the Installation of Air Conditioning and Ventilating Systems of Other Than Residence Type, NFPA No. 90A, and Residence Type Warm Air Heating and Air Conditioning Systems, NFPA No. 90B. Where local regulations are at a variance with instructions, installer should adhere to local codes.

Duct Work

All duct work, supply and return, must be properly sized for the design airflow requirement of the equipment. Air Conditioning Contractors of America (ACCA) is an excellent guide to proper sizing. All duct work or portions thereof not in the conditioned space should be properly insulated in order to both conserve energy and prevent condensation or moisture damage.

Refer to Maximum ESP of operation Electric Heat Table 14 on page 29.

Design the duct work according to methods given by the Air Conditioning Contractors of America (ACCA). When duct runs through unheated spaces, it should be insulated with a minimum of 1" of insulation. Use insulation with a vapor barrier on the outside of the insulation. Flexible joints should be used to connect the duct work to the equipment in order to keep the noise transmission to a minimum.

Model series W18 and W24 are approved for 0" clearance to the supply duct. For model series W30 and W36, a 1/4" clearance to combustible material for the first 3' of duct attached to the outlet air frame is required. See wall mounting instructions on page 6 and Figures 3 – 7 (pages 8 – 12) for further details.

Ducts through the walls must be insulated and all joints taped or sealed to prevent air or moisture entering the wall cavity.

Some installations may not require a return air duct. A metallic return air grille is required with installations not requiring a return air duct. The spacing between louvers on the grille shall not be larger than 5/8".

Any grille that meets with 5/8" louver criteria may be used. It is recommended that Bard Return Air Grille Kits RG2 through RG5 or RFG2 through RFG5 be installed when no return duct is used. Contact distributor or factory for ordering information. If using a return air filter grille, filters must be of sufficient size to allow a maximum velocity of 400 fpm.

NOTE: *If no return air duct is used, applicable installation codes may limit this cabinet to installation only in a single story structure.*

Filters

A 1" throwaway filter is standard with each unit. The filter slides into position making it easy to service. This filter can be serviced from the outside by removing the filter access panel. Additional 1" and 2" filters are also available as optional accessories. The internal filter brackets are adjustable to accommodate the 2" filter by bending two tabs down on each side of the filter support bracket.

Fresh Air Intake

All units are built with fresh air inlet slots punched in the service door.

If the unit is equipped with a fresh air damper assembly, the assembly is shipped already attached to the unit. The damper blade is locked in the closed position. To allow the damper to operate, the maximum and minimum blade position stops must be installed (see Figure 1).

All capacity, efficiency and cost of operation information is based upon the fresh air blank-off plate in place and is recommended for maximum energy efficiency.

The blank-off plate is available upon request from the factory and is installed in place of the fresh air damper shipped with each unit.

FIGURE 1
Fresh Air Damper

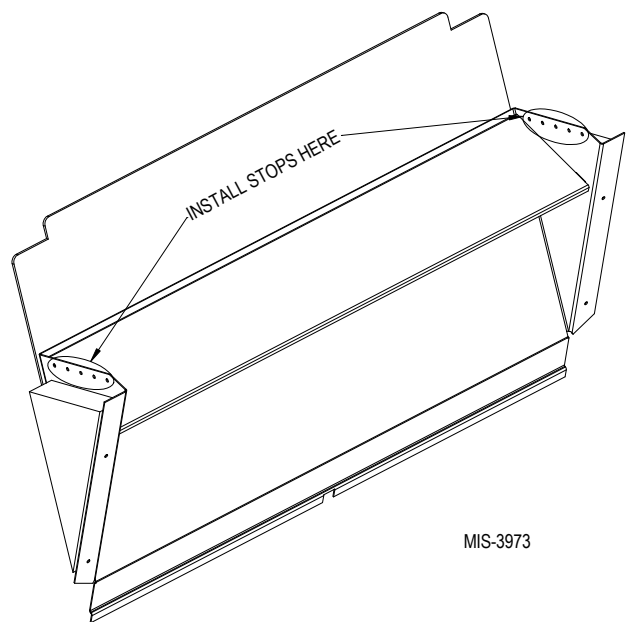

Condensate Drain

A plastic drain hose extends from the drain pan at the top of the unit down to the unit base. There are openings in the unit base for the drain hose to pass through. In the event the drain hose is connected to a drain system of some type, it must be an open or vented type system to assure proper drainage.

INSTALLATION

Wall Mounting Information

- Two holes for the supply and return air openings must be cut through the wall as shown in Figures 3A – B on pages 8 and 9.
- On wood frame walls, the wall construction must be strong and rigid enough to carry the weight of the unit without transmitting any unit vibration.
- Concrete block and brick walls must be thoroughly inspected to insure that they are capable of carrying the weight of the installed unit.

Mounting the Unit

- These units are secured by wall mounting brackets which secure the unit to the outside wall surface at both sides. A bottom mounting bracket, attached to skid for shipping, is provided for ease of installation, but is not required.
- The supply air duct flange and the first 3' of supply air duct require a minimum of 1/4" clearance to combustible material for model series W30 and W36. However, it is generally recommended that a 1" clearance is used for ease of installation and maintaining the required clearance to combustible material. See Figures 3A – B for details on opening sizes.



WARNING

Fire hazard.

Maintain minimum 1/4" clearance between the supply air duct and combustible materials in the first 3' of ducting.

Failure to do so could result in fire causing damage, injury or death.

- Locate and mark lag bolt locations and bottom mounting bracket location (see Figures 3A – B).
- Mount bottom mounting bracket.
- Hook top rain flashing, attached to front-right of supply flange for shipping, under back bend of top.
- Position unit in opening and secure with 5/16 lag bolts; use 7/8" diameter flat washers on the lag bolts.
- Secure rain flashing to wall and caulk across entire length of top (see Figures 3A – B).

- For additional mounting rigidity, the return air and supply air frames or collars can be drilled and screwed or welded to the structural wall itself (depending upon wall construction). Be sure to observe required clearance if combustible wall.
- On side-by-side installations, maintain a minimum of 20" clearance on right side (on W**A units) to allow access to control panel and heat strips and proper airflow to the outdoor coil (20" clearance on left side on W**L units). Additional clearance may be required to meet local or national codes.

TABLE 1
Clearance Required for Service Access and Adequate Condenser Airflow

Model	Left Side	Right Side	Discharge Side
W18A W24A W30A W36A	15"	20"	10'
W18L W24L W30L W36L	20"	15"	10'

NOTE: For side-by-side installation of two W**A models, there must be 20" between units. This can be reduced to 15" by using a W**L model (left side compressor and controls) for the left unit and W**A (right side compressor and controls) for right unit.

See Specifications Sheet S3573.

TABLE 2
Minimum Clearances Required to Combustible Materials

Model	Supply Air Duct (1st 3')	Cabinet
W18A, L W24A, L	0"	0"
W30A, L W36A, L	1/4"	0"

FIGURE 2
Unit Dimensions

	Width (W)	Depth (D)	Height (H)	Supply		Return																
				A	B	C	B	E	F	G	I	J	K	L	M	N	O	P	Q	R	S	T
W18*B W24*B	33.300	17.125	74.563	7.88	19.88	11.88	19.88	35.00	10.88	29.75	20.56	30.75	32.06	33.25	31.00	2.63	34.13	26.06	10.55	4.19	12.00	9.00
W30*B W36*B	38.200	17.125	74.563	7.88	27.88	13.88	27.88	40.00	10.88	29.75	17.93	30.75	32.75	33.25	31.00	2.75	39.13	26.75	9.14	4.19	12.00	9.00

All dimensions are in inches. Dimensional drawings are not to scale.

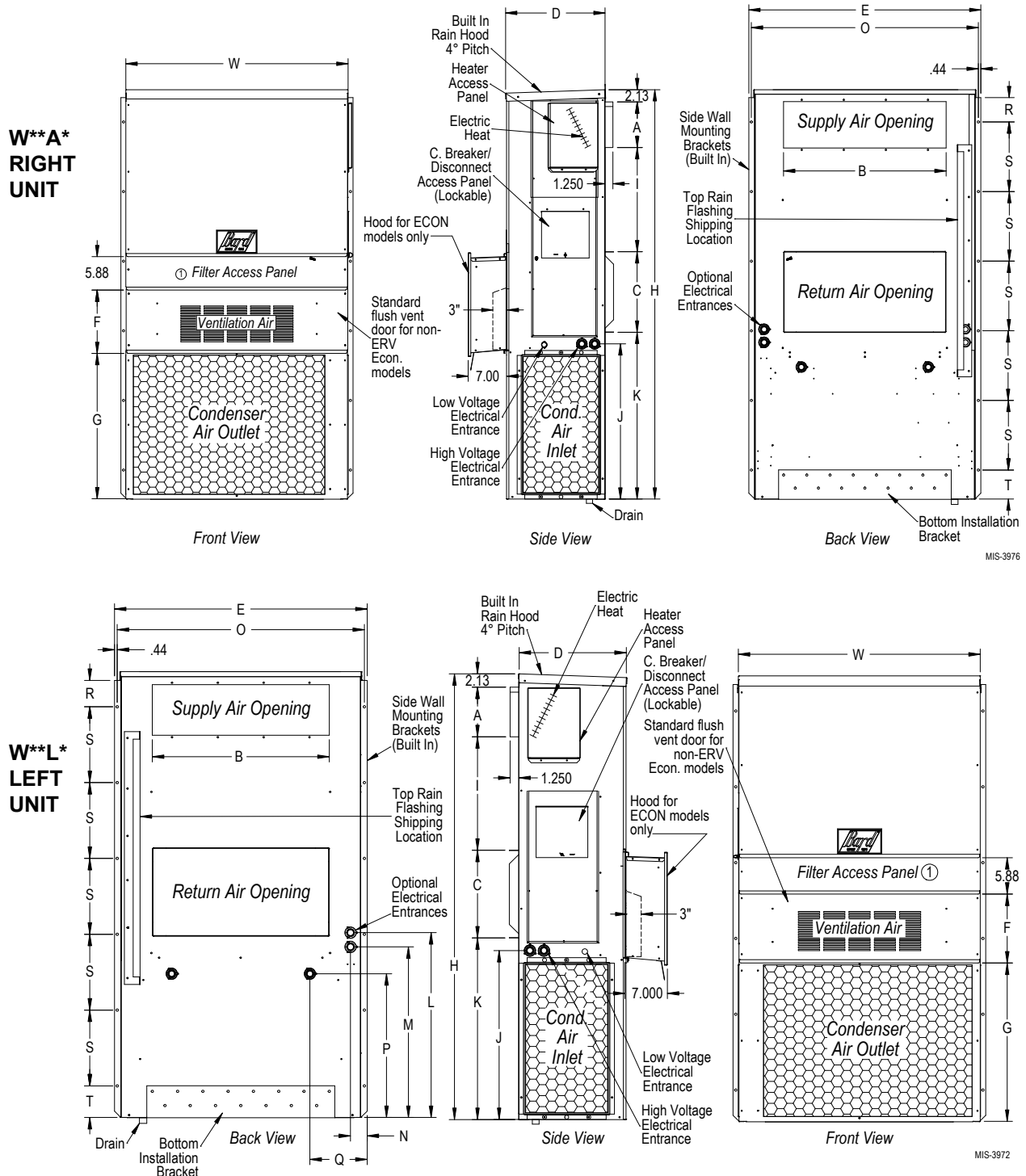
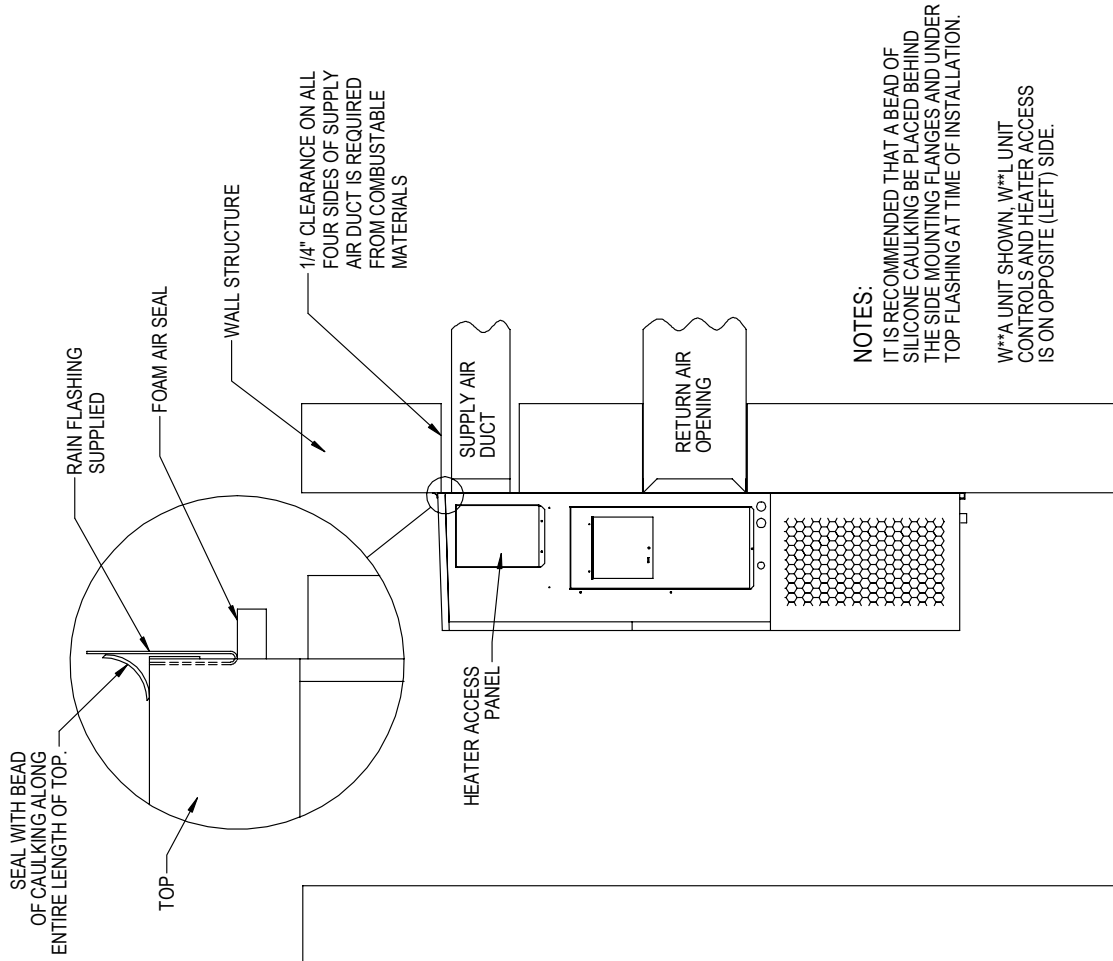

FIGURE 3B
W30AB, W30LB, W36AB, W36LB
Mounting Instructions

	A	B	C	D	E
REQUIRED DIMENSIONS TO MAINTAIN 1/4" MIN. CLEARANCE FROM COMBUSTIBLE MATERIALS	28 3/8	8 3/8	5 3/8	3 11/16	17 5/8
REQUIRED DIMENSIONS TO MAINTAIN RECOMMENDED 1" CLEARANCE FROM COMBUSTIBLE MATERIALS	29 7/8	9 7/8	4 5/8	4 7/16	16 7/8



NOTES:
 IT IS RECOMMENDED THAT A BEAD OF SILICONE CAULKING BE PLACED BEHIND THE SIDE MOUNTING FLANGES AND UNDER TOP FLASHING AT TIME OF INSTALLATION.
 W**A UNIT SHOWN. W**L UNIT CONTROLS AND HEATER ACCESS IS ON OPPOSITE (LEFT) SIDE.

Right Side View

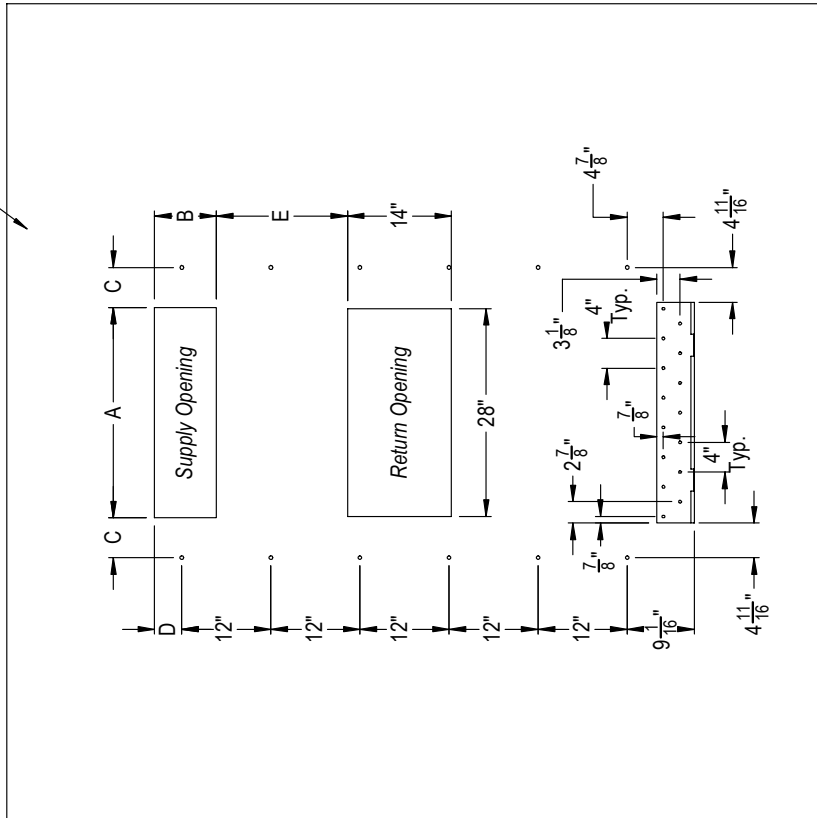

Wall Opening and Hole Location View

MIS-3820

FIGURE 4
Electric Heat Clearance
W30AB, W30LB, W36AB, W36LB

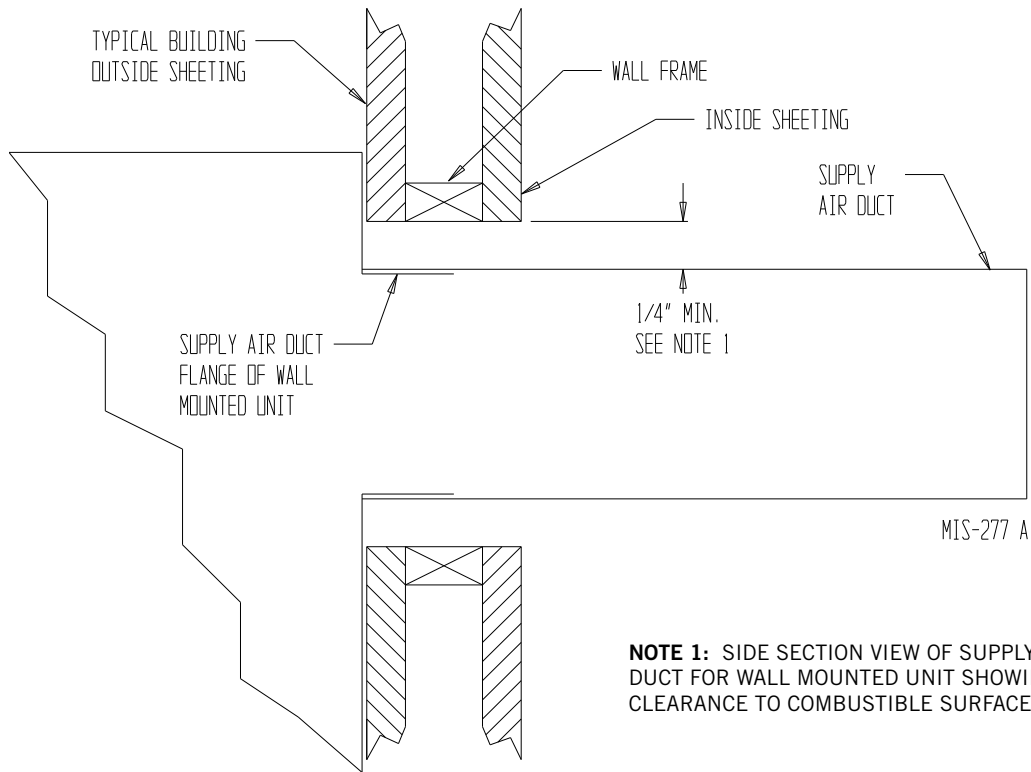

NOTE 1: SIDE SECTION VIEW OF SUPPLY AIR DUCT FOR WALL MOUNTED UNIT SHOWING 1/4" CLEARANCE TO COMBUSTIBLE SURFACES.

WARNING

Fire hazard.

Maintain minimum 1/4" clearance between the supply air duct and combustible materials in the first 3' of ducting.

Failure to do so could result in fire causing damage, injury or death.

FIGURE 5
Wall Mounting Instructions

See Figures 3A and 3B Mounting Instructions

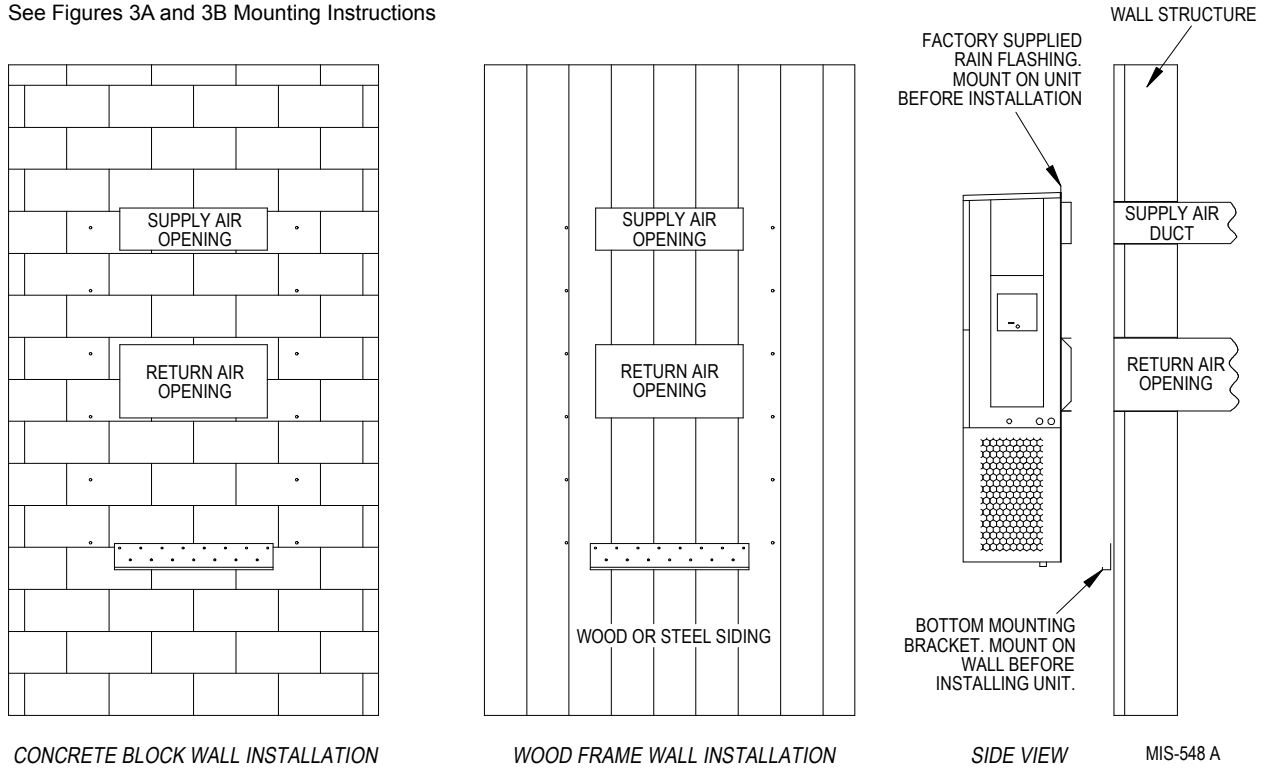

FIGURE 6
Wall Mounting Instructions

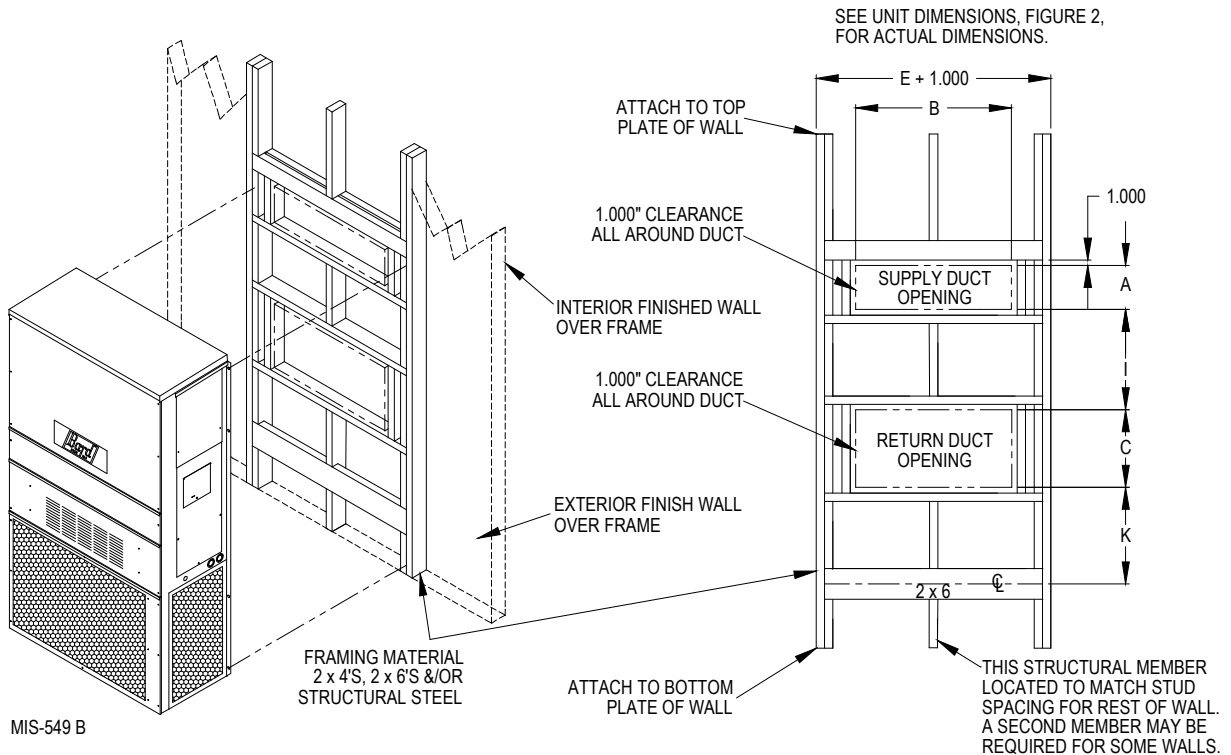
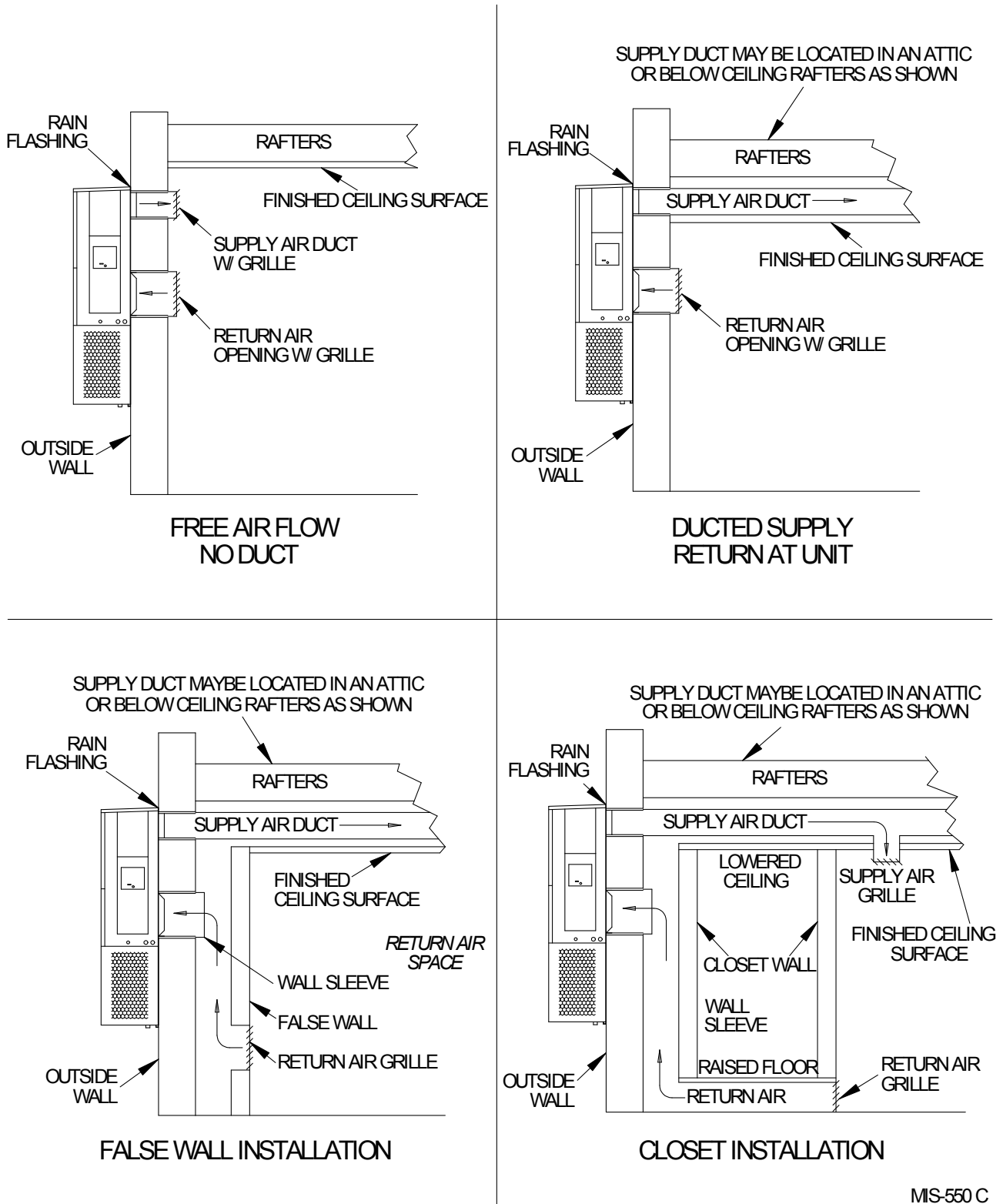

FIGURE 7
Common Wall Mounting Installations



MS-550 C

Wiring – Main Power

Refer to the unit rating plate for wire sizing information and maximum fuse or circuit breaker size. Each outdoor unit is marked with a “Minimum Circuit Ampacity”. This means that the field wiring used must be sized to carry that amount of current. Depending on the installed KW of electric heat, there may be two field power circuits required. If this is the case, the unit serial plate will so indicate. All models are suitable only for connection with copper wire. Each unit and/or wiring diagram will be marked “Use Copper Conductors Only”. These instructions **must be** adhered to. Refer to the National Electrical Code (NEC) for complete current carrying capacity data on the various insulation grades of wiring material. All wiring must conform to NEC and all local codes.

The electrical data lists fuse and wire sizes (75°C copper) for all models including the most commonly used heater sizes. Also shown are the number of field power circuits required for the various models with heaters.

The unit rating plate lists a “Maximum Time Delay Relay Fuse” or circuit breaker that is to be used with the equipment. The correct size must be used for proper circuit protection and also to ensure that there will be no nuisance tripping due to the momentary high starting current of the compressor motor.

The disconnect access door on this unit may be locked to prevent unauthorized access to the disconnect. To convert for the locking capability, bend the tab located in the bottom left-hand corner of the disconnect opening under the disconnect access panel straight out. This tab will now line up with the slot in the door. When shut, a padlock may be placed through the hole in the tab preventing entry.

See “Start Up” section for important information on three phase scroll compressor start ups.

See Tables 11 and 12 on pages 25 and 26 for electrical specifications.

Wiring – Low Voltage

All 230/208V 1 phase and 3 phase equipment have dual primary voltage transformers. All equipment leaves the factory wired on 240V tap. For 208V operation, reconnect from 240V to 208V tap. The acceptable operating voltage range for the 240 and 208V taps are:

Tap: 240 Range: 253 – 216
Tap: 208 Range: 220 – 187

NOTE: *The voltage should be measured at the field power connection point in the unit and while the unit is operating at full load (maximum amperage operating condition).*

For low voltage wiring, an 18 gauge copper, color-coded cable is recommended. See Table 7 on page 14 for more information.

Low Voltage Connections

These units use a 24-volt AC low voltage circuit. The **RT** terminal is the 24V transformer output, and the **R** terminal is the 24VAC *hot* terminal for the operation of the equipment. RT and R are connected with a brass jumper bar which can be removed and RT and R connected to an external NC (normally closed) contact such as a fire/smoke detector that will cause immediate shutdown of the equipment upon activation.

C terminal is the *24VAC common and is grounded.*

G terminal is the *indoor blower input.*

Y1 terminal is the *1st Stage input for cooling.*

Y2 terminal is the *2nd Stage compressor input for cooling (if equipped with an economizer)* or disables Balanced Climate mode if jumper is removed on units without an economizer (see page 18).

B/W1 terminal is the *1st stage electric heat.*

W2 terminal is the *2nd stage heat (if equipped).*

A terminal is the *ventilation input.* This terminal energizes any factory-installed ventilation option and indoor blower.

D terminal is the *dehumidification input.* If installed, this terminal energizes any factory-installed dehumidification option.

L terminal is *24 volt alarm active output.*

For units equipped with an alarm relay:

1 terminal is the *normally closed contact on the relay.*

2 terminal is the *normally open contact on the relay.*

3 terminal is the *common contact on the relay.*

See Table 3 for additional low voltage connections.

TABLE 3
Additional Low Voltage Connections (if applicable)

Terminal	Unit	Description
9	V Control Option Only	Discharge Air Sensor, 10K Ohm
10	V Control Option Only	Discharge Air Sensor, 10K Ohm
11	F, V Control Options	Filter Switch, Normally Open Contact
12	F, V Control Options	Filter Switch, Normally Open Contact
13	V Control Option Only	Blower Airflow Switch, Normally Open Contact
14	V Control Option Only	Blower Airflow Switch, Normally Open Contact
15	V Control Option Only	Compressor Current Sensor, Normally Open Contact
16	V Control Option Only	Compressor Current Sensor, Normally Open Contact

See Table 4 on page 14 for low voltage connections for DDC control.

TABLE 4
Low Voltage Connections for DDC Control

	Standard Units	Units w/ Economizers
Fan Only	Energize G	Energize G
1st Stage Cooling Mode	Energize Y1, G	Energize Y1, G
2nd Stage Cooling Mode	Energize Y2 to override Balanced Climate mode when Y1-Y2 jumper is removed	Energize Y1, Y2, G
1st Stage Heating	Energize B/W1	Energize B/W1
2nd Stage Heating (if employed)	Energize B/W1, W2	Energize B/W1, W2
Ventilation	Energize A	Energize A
Dehumidification (if employed)	Energize D	Energize D

TABLE 5
Humidity Controls

Part Number	Predominate Features
8403-038 (H600A1014)	SPDT switching, pilot duty 50VA @ 24V; Humidity range 20-80% RH
8403-047 (H200-10-21-10)	Electronic dehumidstat SPST closes-on-rise; Humidity range 10-90% with adjustable stops

TABLE 6
CO₂ Controllers

Part Number	Predominate Features
8403-056	CO ₂ ventilation control with digital display. Normally Open SPST (Default: Close at 800ppm)
8403-067	Normally Open SPST relay closes-on-rise 24V dual wave length sensor. Default setting 950ppm, adjustable to 0-2000ppm Default off setting 1000ppm, adjustable to 0-200 ppm can be calibrated

TABLE 7
Thermostat Wire Size

Transformer VA	FLA	Wire Gauge	Maximum Distance In Feet
55	2.3	20 gauge	45
		18 gauge	60
		16 gauge	100
		14 gauge	160
		12 gauge	250

TABLE 8
Wall Thermostats

Part Number	Predominate Features
8403-057 (TH3110D1040)	1 stage Cool, 1 stage Heat; Electronic Non-Programmable; Auto or Manual changeover
8403-059 (TH5220D1219/U)	2 stage Cool, 2 stage Heat; Electronic Non-Programmable; HP or Conventional (Default: AC); Auto or Manual changeover
8403-060 (1120-445)	3 stage Cool; 3 stage Heat; Electronic Programmable/Non-Programmable; HP or Conventional; Auto or Manual changeover; Dehumidification Output
CS9B-THO	3 stage Cool, 3 stage Heat; Programmable/Non-Programmable; HP or Conventional; Auto or Manual Changeover; Humidity Sensor w/ dehumidification; Motion Sensor w/Intelligent Learning Control; BACnet-compatible
CS9B-THOC	3 stage Cool, 3 stage Heat; Programmable/Non-Programmable; HP or Conventional; Auto or Manual Changeover; Humidity Sensor w/ dehumidification; CO ₂ Sensor; Motion Sensor w/Intelligent Learning Control; BACnet-compatible
CS9BE-THO	3 stage Cool, 3 stage Heat; Programmable/Non-Programmable; HP or Conventional; Auto or Manual Changeover; Humidity Sensor w/ dehumidification; Motion Sensor w/Intelligent Learning Control; BACnet-compatible; Ethernet-compatible
CS9BE-THOC	3 stage Cool, 3 stage Heat; Programmable/Non-Programmable; HP or Conventional; Auto or Manual Changeover; Humidity Sensor w/dehumidification; CO ₂ Sensor; Motion Sensor w/Intelligent Learning Control; BACnet-compatible; Ethernet-compatible
8403-089 (T4 Pro)	1 stage Cool, 1 stage Heat – Heat Pump; 1 stage Cool, 1 stage Heat – Conventional; Programmable/Non-Programmable Electronic; Auto or Manual changeover
8403-090 (T6 Pro)	2 stage Cool, 3 stage Heat – Heat Pump; 2 stage Cool, 2 stage Heat – Conventional; Programmable/Non-Programmable Electronic; Auto or Manual changeover
8403-091	1 stage Cool, 1 stage Heat; Non-Programmable; FEMA use
8403-092 (T6 Pro Wi-Fi)	2 stage Cool, 3 stage Heat – Heat Pump; 2 stage Cool, 2 stage Heat – Conventional; Programmable/Non-Programmable Electronic; Auto or Manual changeover; Wi-Fi

FIGURE 8
Programmable Thermostat Connections

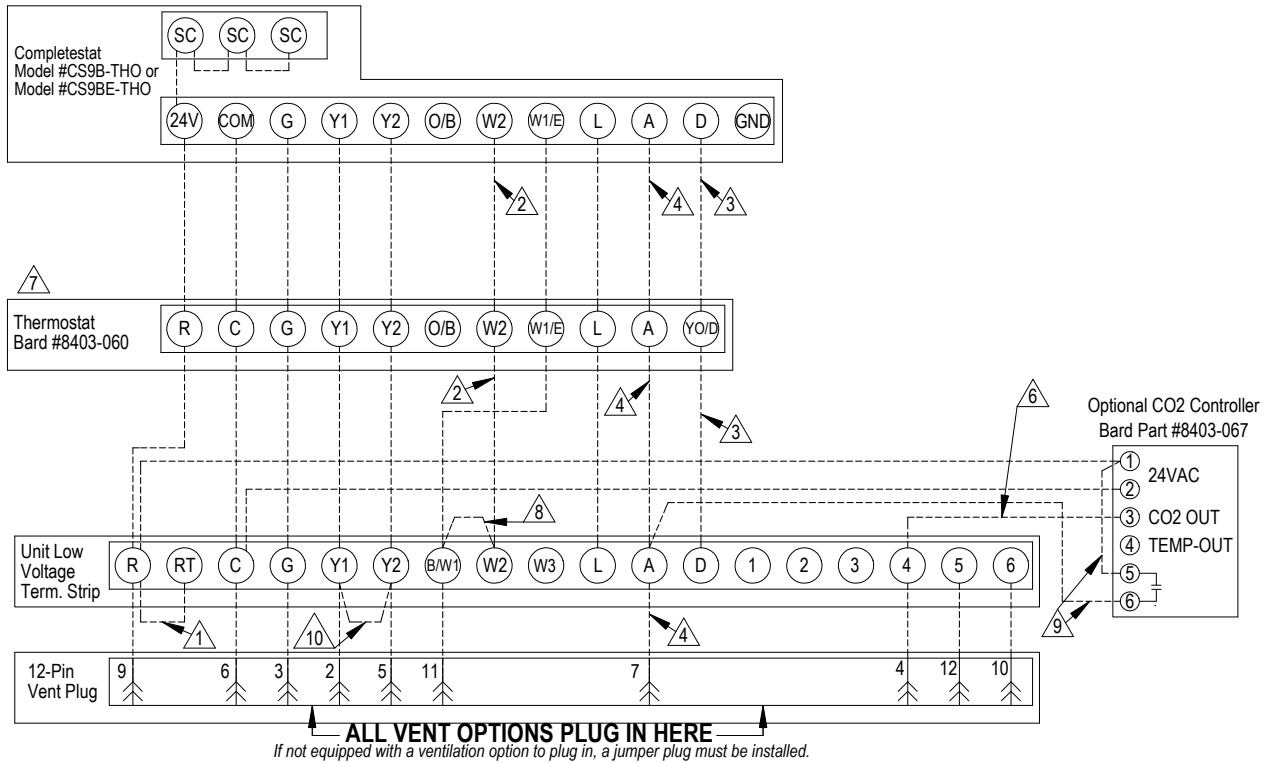

- ① Factory installed jumper. Remove jumper and connect to N.C fire alarm circuit if emergency shutdown required.
- ② Wire not needed below 15KW.
- ③ Wire required for dehumidification models only.
- ④ Do not connect "A" from thermostat if optional CO2 controller is used
- ⑤ Relay Provided with Completestat
- ⑥ 0-10 VDC modulating CO2 control signal for modulating ventilation control (optional for ECON only - see vent instruction manuals)
- ⑦ Change model configuration from heat pump to heat/cool. Must be configured to programmable and fan set to be programmed fan for the "A" output to function during scheduled occupied periods. Must be configured for multi-stage for Y1 output to be active 1st stage cooling. For dehumidification, must be configured for "No Economizer" for YO/D to be active for humidity control.
- ⑧ Install jumper for 1 stage electric heat on units with less than 15KW
- ⑨ Do not add these wires if setting up for modulating control. See note 7.
- ⑩ Factory installed jumper. Remove jumper to activate Balanced Climate™ mode.

MIS-3974

FIGURE 9
Thermostat Connections

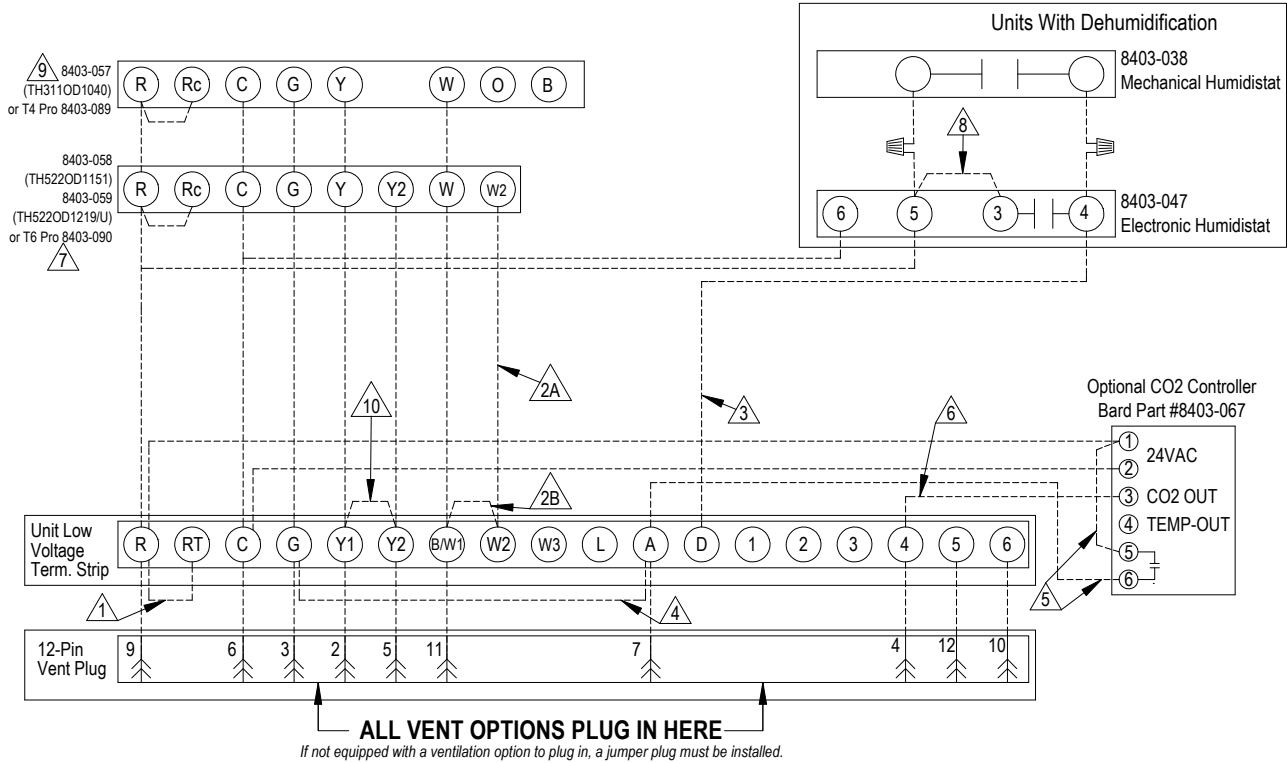

ALL VENT OPTIONS PLUG IN HERE
If not equipped with a ventilation option to plug in, a jumper plug must be installed.

- ⚠ Factory installed jumper. Remove jumper and connect to N.C fire alarm circuit if emergency shutdown required.
- ⚠ Wire not needed below 15KW.
- ⚠ Install Jumper for 1 stage electric heat on units with more than 10KW.
- ⚠ Wire required for dehumidification models only.
- ⚠ For vent operation, add jumper if optional CO2 controller is not used. Vent will run while blower is energized.
- ⚠ Do not add these wires if setting up for modulating control. See note 7.
- ⚠ 0-10 VDC Modulating CO2 control signal for modulating ventilation control (Optional for ECON Only) - See vent installation manual.
- ⚠ For 8403-058, change "system type", set up Function 1, From 5 (2 Heat/ 1 Cool heat Pump) to 6 (2 Heat / 2 Cool Conventional). For 8403-059, No change required.
- ⚠ Jumper needs added.
- ⚠ Thermostat will not work with units equipped with economizers.
- ⚠ Factory installed jumper. Remove jumper to activate Balanced Climate™ Mode

MIS-3975

NOTICE

These units require R-410A refrigerant and polyol ester oil.

General

1. Use separate service equipment to avoid cross contamination of oil and refrigerants.
2. Use recovery equipment rated for R-410A refrigerant.
3. Use manifold gauges rated for R-410A (800 psi/250 psi low).
4. R-410A is a binary blend of HFC-32 and HFC-125.
5. R-410A is nearly azeotropic—similar to R-22 and R-12. Although nearly azeotropic, charge with liquid refrigerant.
6. R-410A operates at 40-70% higher pressure than R-22 and systems designed for R-22 cannot withstand this higher pressure.
7. R-410A has an ozone depletion potential of zero, but must be reclaimed due to its global warming potential.
8. R-410A compressors use polyol ester oil.
9. Polyol ester oil is hygroscopic; it will rapidly absorb moisture and strongly hold this moisture in the oil.
10. A liquid line dryer must be used—even a deep vacuum will not separate moisture from the oil.
11. Limit atmospheric exposure to 15 minutes.
12. If compressor removal is necessary, always plug compressor immediately after removal. Purge with small amount of nitrogen when inserting plugs.

Topping Off System Charge

If a leak has occurred in the system, Bard Manufacturing recommends reclaiming, evacuating (see criteria above) and charging to the nameplate charge. If done correctly, topping off the system charge can be done without problems.

With R-410A, there are no significant changes in the refrigerant composition during multiple leaks and recharges. R-410A refrigerant is close to being an azeotropic blend (it behaves like a pure compound or single component refrigerant). The remaining refrigerant charge, in the system, may be used after leaks have occurred and then “top-off” the charge by utilizing the pressure charts on the inner control panel cover as a guideline.

REMEMBER: When adding R-410A refrigerant, it must come out of the charging cylinder/tank as a liquid to avoid any fractionation, and to ensure optimal system performance. Refer to instructions for the cylinder that is being utilized for proper method of liquid extraction.

Safety Practices

1. Never mix R-410A with other refrigerants.
2. Use gloves and safety glasses. Polyol ester oils can be irritating to the skin, and liquid refrigerant will freeze the skin.
3. Never use air and R-410A to leak check; the mixture may become flammable.
4. Do not inhale R-410A—the vapor attacks the nervous system, creating dizziness, loss of coordination and slurred speech. Cardiac irregularities, unconsciousness and ultimate death can result from breathing this concentration.
5. Do not burn R-410A. This decomposition produces hazardous vapors. Evacuate the area if exposed.
6. Use only cylinders rated DOT4BA/4BW 400.
7. Never fill cylinders over 80% of total capacity.
8. Store cylinders in a cool area, out of direct sunlight.
9. Never heat cylinders above 125°F.
10. Never trap liquid R-410A in manifold sets, gauge lines or cylinders. R-410A expands significantly at warmer temperatures. Once a cylinder or line is full of liquid, any further rise in temperature will cause it to burst.

Important Installer Note

For improved start up performance, wash the indoor coil with a dishwashing detergent.

High Pressure Switch

All W**A/W**L wall-mounted air conditioner series models are supplied with a remote reset for the high and low pressure switch. If tripped, the pressure switch may be reset by turning the thermostat off then back on again. High pressure switch settings: Opens 650 +/- 15 PSI, Closes 520 +/- 15 PSI.

Three Phase Scroll Compressor Start Up Information

Scroll compressors, like several other types of compressors, will only compress in one rotational direction. Direction of rotation is not an issue with single phase compressors since they will always start and run in the proper direction.

However, three phase compressors will rotate in either direction depending upon phasing of the power. Since there is a 50-50 chance of connecting power in such a way as to cause rotation in the reverse direction, verification of proper rotation must be made. Verification of proper rotation direction is made by observing that suction pressure drops and discharge pressure rises when the compressor is energized. Reverse rotation also results in an elevated sound level over that with correct rotation, as well as substantially reduced current draw compared to tabulated values.

Verification of **proper rotation** must be made at the time the equipment is put into service. If improper rotation is corrected at this time, there will be no negative impact on the durability of the compressor. However, reverse operation for over 1 hour may have a negative impact on the bearing due to oil pump out.

NOTE: *If compressor is allowed to run in reverse rotation for an extended period of time, the compressor's internal protector will trip.*

All three phase compressors are wired identically internally. As a result, once the correct phasing is determined for a specific system or installation, connecting properly phased power leads to the same Fusite terminal should maintain proper rotation direction.

The direction of rotation of the compressor may be changed by reversing any two line connections to the unit.

Phase Monitor

All units with three phase scroll compressors are equipped with a three phase line monitor to prevent compressor damage due to phase reversal.

The phase monitor in this unit is equipped with two LEDs. If the Y signal (call for cooling) is present at the phase monitor and phases are correct, the green LED will light.

If phases are reversed, the red fault LED will be lit and compressor operation is inhibited.

If a fault condition occurs, reverse two of the supply leads to the unit. **Do not reverse any of the unit factory wires as damage may occur.**

Condenser Fan Operation

NOTE: *Certain models may be equipped with a low ambient control (LAC), and if so, the condenser fan motor will have a delayed start until system refrigerant operating pressure builds up. After starting, the fan motor may or may not cycle depending upon ambient conditions. This is normal operation.*

50 Hz models must have fan wired on low speed. These models are factory wired on low speed.

Service Hints

1. Caution owner/operator to maintain clean air filters at all times and also not to needlessly close off supply and return air registers. This reduces airflow through the system, which shortens equipment service life as well as increasing operating costs.
2. Check all power fuses or circuit breakers to be sure they are the correct rating.
3. Periodic cleaning of the outdoor coil to permit full and unrestricted airflow circulation is essential.

Sequence of Operation

COOLING – Circuit R-Y1 makes at thermostat pulling in compressor contactor, starting the compressor and outdoor motor. (See **NOTE** under **CONDENSER FAN OPERATION** concerning models equipped with low ambient control.) The G (indoor motor) circuit is automatically completed by the thermostat on any call for cooling operation or can be energized by manual fan switch on subbase for constant air circulation. On a call for heating, circuit R-W1 makes at the thermostat pulling in heat contactor for the strip heat and blower operation. On a call for second stage heat, R-W2 makes bringing on second heat contactor, if so equipped.

Balanced Climate™ Mode

All units are equipped with the capability of running in Balanced Climate mode. This is a mode to enhance the comfort level by slowing the indoor blower speed to help extract more humidity during cooling operation. In order to activate this mode, the jumper bar between terminals Y1 and Y2 on the low voltage terminal block must be removed. The indoor blower will then run at a lower speed in cooling mode. This low speed can be overridden by utilizing a 2-stage thermostat. If the call for cooling is not satisfied within a given time frame (specified by the thermostat), the thermostat will send a signal to Y2 which then increases the blower speed back to the selected speed. See pages 27 and 28 for blower speed selection options.

Vent Connection Plug

All units are equipped with a vent connection plug in the side of the control panel for the different ventilation packages to plug in to. If the compressor will not start and there is no "Y1" at the compressor control module, first check to make sure that either the optional vent is plugged into the vent connection plug or the supplied jumper plug is in place. **The unit will not operate without anything plugged in.** This plug is located on the side of the control panel behind the front vent door (behind the filter access door). If the unit is supplied with a factory-installed vent package, it will be plugged in but the jumper plug will also be tethered next to the connection for troubleshooting purposes, if necessary.

Compressor Control Module

The compressor control module (CCM) is standard on all models covered by this manual.

Features

Delay-on-Make Timer
 Short Cycle Protection/Delay-on-Break
 Low Pressure Detection
 High Pressure Detection
 LPC and HPC Status LEDs
 Test Mode
 Brownout Protection with Adjustment

Delay-on-Make Timer

A delay-on-make timer is included to be able to delay startup of the compressor. This is desired when more than one unit is on a structure so that all of the units do not start at the same time which could happen after a power loss or building shutdown. The delay-on-make time period is 2 minutes plus 10% of the delay-on-break time period. To ensure that all of the units do not start at the same time, adjust the delay-on-break timer on each unit to a slightly different delay time.

Short Cycle Protection/Delay-on-Break

An anti-short cycle timer is included to prevent short cycling the compressor. This is adjustable from 30 seconds to 5 minutes via the adjustment knob (see Figure 10). Once a compressor call is lost, the time period must expire before a new call will be initiated.

Low Pressure Detection

Low pressure switch monitoring allows for a lockout condition in a situation where the switch is open. If the low pressure switch remains open for more than 2 minutes, the CCM will de-energize the compressor for the delay-on-break time. If the switch closes again, it will then restart the compressor. If the switch trips again during the same Y call, the compressor will be de-energized and the alarm terminal will be energized indicating an alarm. The blue LED will light and stay on until power is cycled to the control or a loss of voltage is present at Y terminal for more than 1/2 second.

FIGURE 10
 8201-164 Compressor Control Module

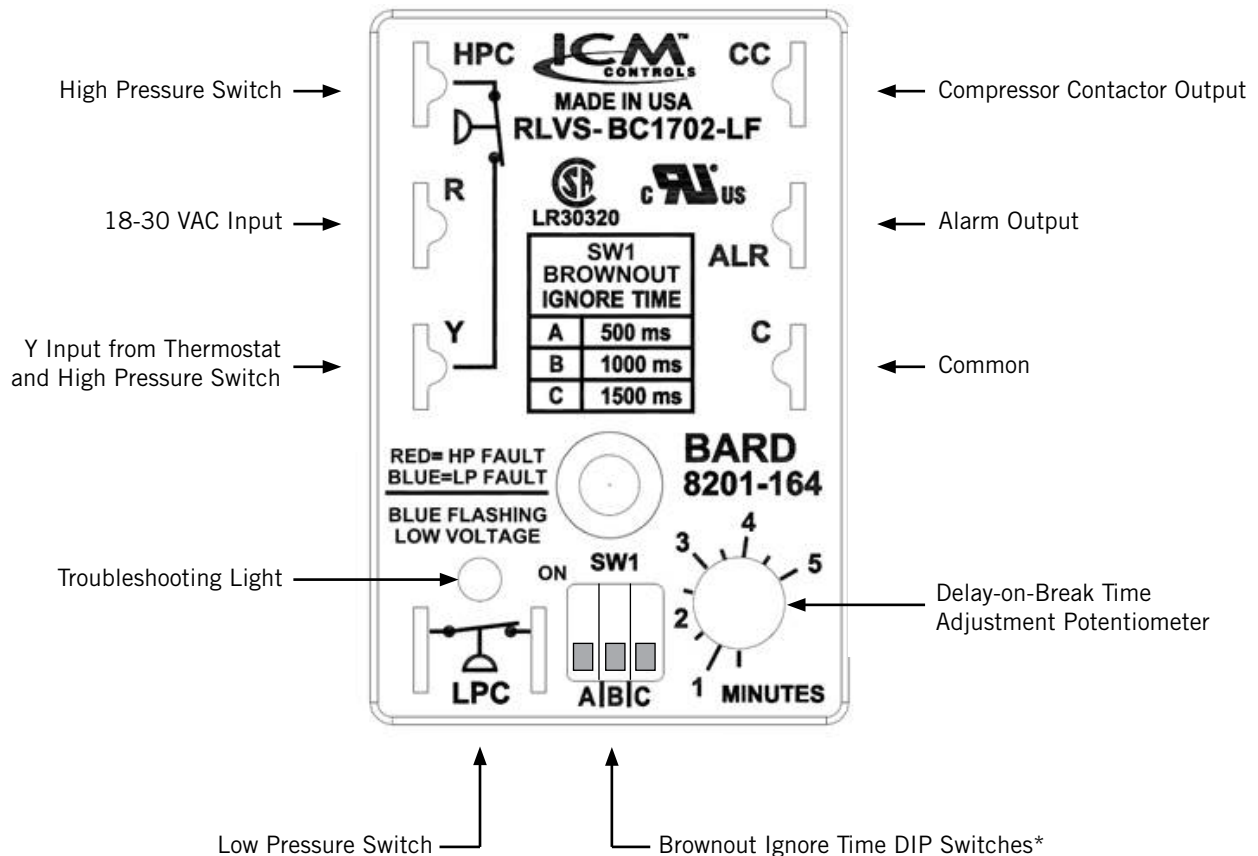

* Turn on only one switch for that specific ignore time setting

High Pressure Detection

High pressure switch monitoring allows for a lockout condition in a situation where the switch is open. If the high pressure switch opens, the CCM will de-energize the compressor. If the switch closes again, it will then restart the compressor after the delay-on-break setting has expired on the device. If the switch trips again during the same thermostat call, the compressor will be de-energized and the alarm terminal will be energized indicating an alarm. The red LED will light and stay on until power is cycled to the control or a loss of voltage is present at Y terminal for more than ½ second.

Test Mode

By rapidly rotating the potentiometer (POT) clockwise (see Figure 10 on page 19), all timing functions will be removed for testing.

The conditions needed for the unit to enter test mode are as follows: POT must start at a time less than or equal to the 40 second mark. The POT must then be rapidly rotated to a position greater than or equal to the 280 second mark in less than ¼ second. Normal operation will resume after power is reset or after the unit has been in test mode for at least 5 minutes.

Brownout Protection with Adjustment

Brownout protection may be necessary if the utility power or generator power has inadequate power to prevent the voltage from dropping when the compressor starts. This is rare but can happen if the generator is undersized at the site or if the site is in a remote location far from the main power grid. Under normal circumstances, allowing the brownout to be ignored for a time period should not be needed. The 8201-164 is shipped with all the DIP switches in the 'off' or 'do not ignore' position (see Figure 10 on page 19).

If ignoring the brownout is needed because of the above conditions, three preset timers can be set by DIP switches in order to delay signaling a power brownout for a specific length of time after compressor contactor is energized. This allows the compressor a time period to start even if the voltage has dropped and allows the voltage to recover. This delay only happens when the CC terminal energizes. The delay can be set to 500 milliseconds (A DIP switch), 1000 milliseconds (B DIP switch) or 1500 milliseconds (C DIP switch); time is not cumulative—only the longest setting will apply. If the voltage recovers during the brownout time period, the compressor will start.

If a brownout condition is detected by the 8201-164, the troubleshooting light will flash blue. The light will continue to flash until the cooling call is satisfied or power is removed from the Y terminal. This condition does not prevent operation, it only indicates that a brownout condition was present at some point during the cooling call. If a brownout condition is detected,

CC will be de-energized and will retry after the delay-on-make timer is satisfied; this process will continue until call is satisfied.

If user chooses the 'do not ignore' position when the site has inadequate utility or generator power, this could lead to the compressor never starting. The control will see the brownout immediately and not start.

A common scenario and one that has been seen in the field is when a unit or units switches from utility power to generator power. With slower transfer switches, the time delay between the utility power and generator power didn't cause a problem. The units lost power, shut off and came back on line normally. With the introduction of almost instantaneous transfer switches, the millisecond long power glitch can be enough that the compressor will start to run backwards. In this scenario, the CCM will catch this and restart the units normally.

Pressure Service Ports

High and low pressure service ports are installed on all units so that the system operating pressures can be observed. A pressure table covering all models can be found on page 24. It is imperative to match the correct pressure table to the unit by model number.

This unit employs high-flow Coremax valves instead of the typical Shrader type valves.

WARNING! Do NOT use a Schrader valve core removal tool with these valves. Use of such a tool could result in eye injuries or refrigerant burns!

To change a Coremax valve without first removing the refrigerant, a special tool is required which can be obtained at www.fastestinc.com/en/SCCA07H. See the replacement parts manual for replacement core part numbers.

Troubleshooting NIDEC SELECTECH Series ECM Motors

If the Motor Is Running

1. It is normal for the motor to rock back and forth on start up. Do not replace the motor if this is the only problem identified.
2. If the system is excessively noisy, does not appear to change speeds in response to a demand (Heat, Cool, Other) or is having symptoms during the cycle such as tripping limit or freezing coil, check the following:
 - A. Wait for programmed delays to time out.
 - B. Ensure that the motors control inputs are wired as shown in the factory-supplied wiring diagram to ensure motor is getting proper control signals and sequencing.
 - C. Remove the filter and check that all dampers, registers and grilles are open and free flowing. If removing the filters corrects the problem, clean or replace with a less restrictive filter. Also check and clean the blower wheel or coil as necessary.

- D. Check the external static pressure (total of both supply and return) to ensure it is within the range as listed on the unit serial plate. If higher than allowed, additional duct work is needed.
- E. If the motor does not shut off at the end of the cycle, wait for any programmed delays to time out (no more than 90 seconds). Also make sure that there is no call for "Continuous Fan" on the G terminal.
- F. If the above diagnostics do not solve the problem, confirm the voltage checks in the next section below, then continue with the **Model SelectTech Communication Diagnostics**.

If the Motor Is Not Running

1. Check for proper high voltage and ground at the L/L1, G, N/L2 connections at the motor (see Figure 11). Correct any voltage issues before proceeding to the next step. The SelectTech motor is voltage specific. Only the correct voltage should be applied to the proper motor. Input voltage within plus or minus 10% of the nominal line power VAC is acceptable.

FIGURE 11
Motor Connections

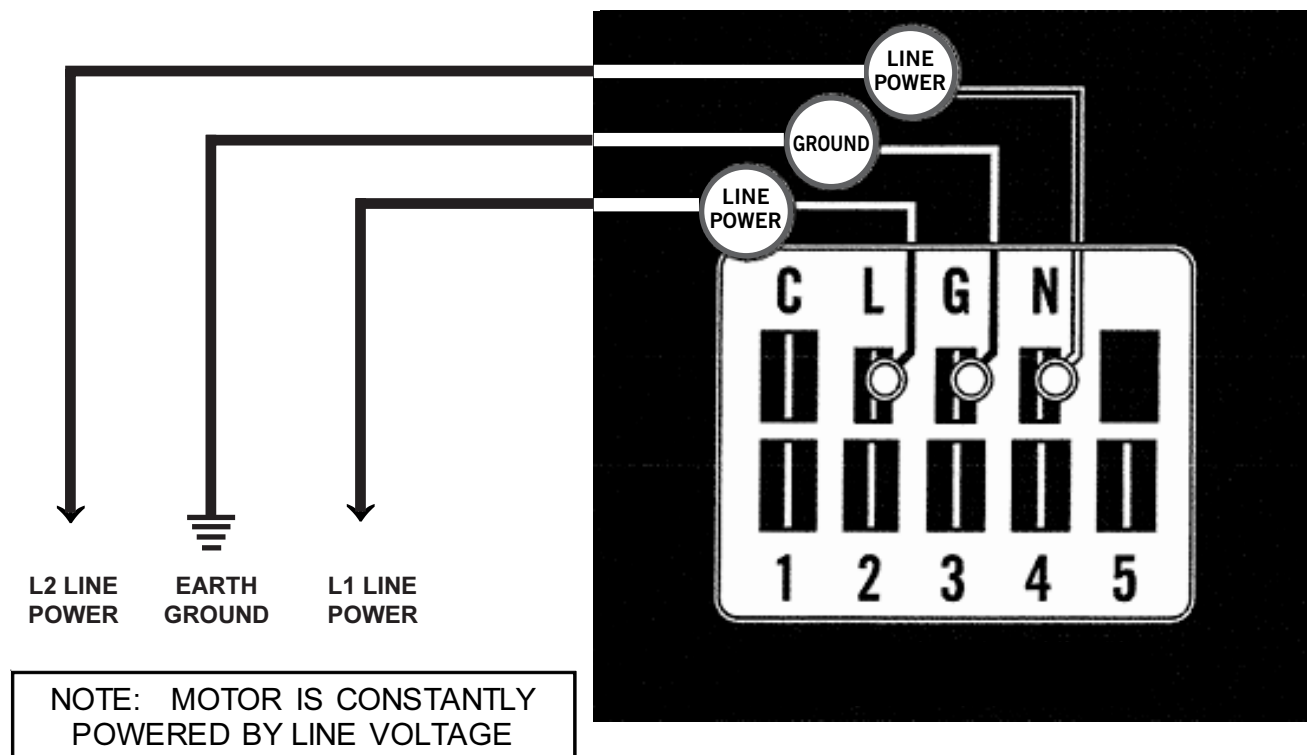

- If the motor has proper high voltage and ground at the L/L1, G, N/L2 connections, then continue with the **Model SelecTech Communication Diagnostics**.

Model SelecTech Communication Diagnostics

The SelecTech motor is communicated through 24 VAC low voltage (thermostat control circuit wiring).

- Start with unit wiring diagram to confirm proper connections and voltage (see Figure 12).
- Initiate a demand from the thermostat and check the voltage between the common and the appropriate motor terminal (1-5). (G input is typically on terminal #1, but always refer to wiring diagram.)

- If the low voltage communication is not present, check the demand from the thermostat. Also check the output terminal and wire(s) from the terminal strip or control relay(s) to the motor.
- If the motor has proper high voltage (verified in Step 1 of **If the Motor Is Not Running** on page 21), proper low voltage to a programmed terminal and is not operating, the motor is failed and will require replacement.

FIGURE 12
Motor Connections

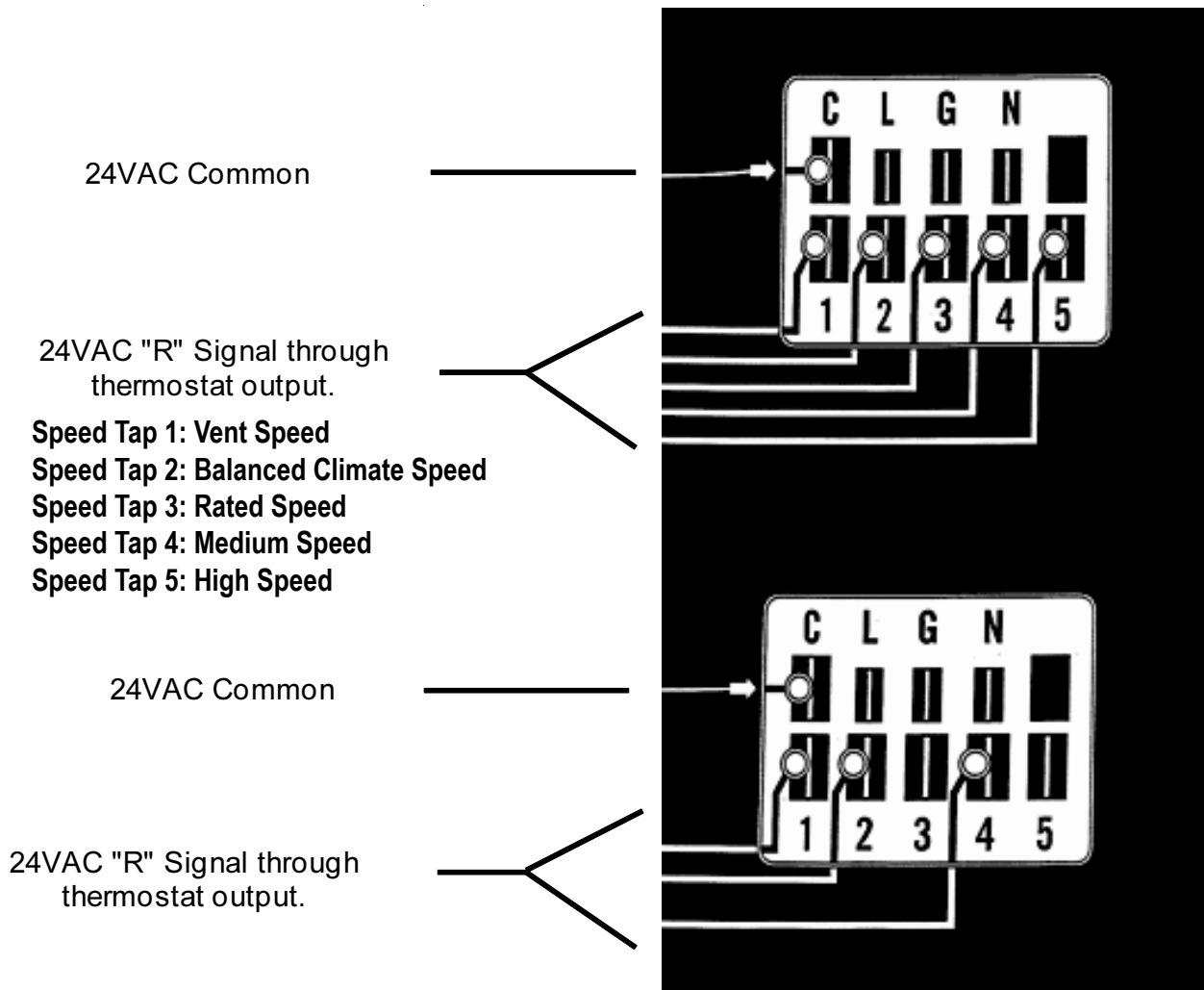

Fan Blade Setting Dimensions

Shown in Figure 13 is the correct fan blade setting for proper air delivery across the outdoor coil. Refer to Table 9 for unit specific dimension.

Any service work requiring removal or adjustment in the fan and/or motor area will require that the dimensions below be checked and blade adjusted in or out on the motor shaft accordingly.

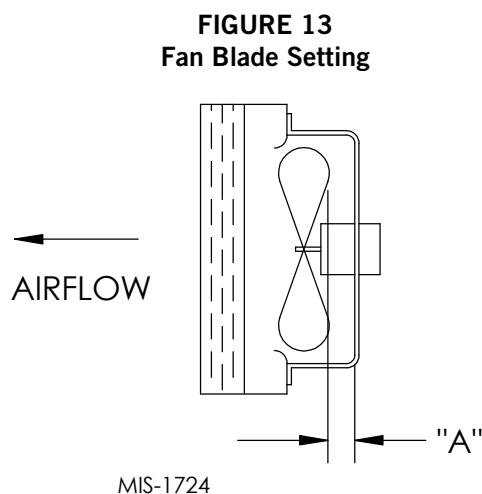

TABLE 9
Fan Blade Dimensions

Model	Dimension A
W18AB/W18LB W24AB/W24LB	1.00"
W30AB/W30LB W36AB/W36LB	1.25"

R-410A Refrigerant Charge

This unit was charged at the factory with the quantity of refrigerant listed on the serial plate. AHRI capacity and efficiency ratings were determined by testing with this refrigerant charge quantity.

The following pressure table shows nominal pressures for the units. Since many installation specific situations can affect the pressure readings, this information should only be used by certified technicians as a guide for evaluating proper system performance. They shall not be used to adjust charge. If charge is in doubt, reclaim, evacuate and recharge the unit to the serial plate charge.

Removal of Fan Shroud

1. Disconnect all power to the unit.
2. Remove the screws holding both grilles, one on each side of unit, and remove grilles.
3. Remove nine screws holding fan shroud to condenser and bottom.
4. Unwire condenser fan motor.
5. Slide complete motor, fan blade and shroud assembly out the left side of the unit.
6. Service motor/fan as needed.
7. Reverse steps to reinstall.

TABLE 10
Cooling Pressure

Air Temperature Entering Outdoor Coil °F

Model	Return Air Temp (DB/WB)	Pressure	75	80	85	90	95	100	105	110	115	120	125	131
W18A/L	75/62	Low Side	120	122	126	129	132	134	137	138	139	141	142	144
		High Side	296	318	340	364	388	413	440	466	494	524	553	590
	80/67	Low Side	128	131	135	138	141	143	146	148	149	151	152	154
		High Side	304	326	349	373	398	424	451	478	507	537	567	605
	85/72	Low Side	132	136	140	143	146	148	151	153	154	156	157	159
		High Side	315	337	361	386	412	439	467	495	525	556	587	626
W24A/L	75/62	Low Side	120	123	126	129	132	134	137	138	140	142	143	145
		High Side	299	321	343	367	391	415	441	468	495	524	552	588
	80/67	Low Side	128	132	135	138	141	143	146	148	150	152	153	155
		High Side	307	329	352	376	401	426	452	480	508	537	566	603
	85/72	Low Side	132	137	140	143	146	148	151	153	155	157	158	160
		High Side	318	341	364	389	415	441	468	497	526	556	586	624
W30A/L	75/62	Low Side	122	124	126	129	131	133	135	137	138	140	142	144
		High Side	317	337	360	383	409	435	462	490	520	551	583	625
	80/67	Low Side	130	133	135	138	140	142	144	146	148	150	152	--*
		High Side	325	346	369	393	419	446	474	503	533	565	598	--*
	85/72	Low Side	135	138	140	143	145	147	149	151	153	155	157	--*
		High Side	336	358	382	407	434	462	491	521	552	585	619	--*
W36A/L	75/62	Low Side	128	130	132	133	135	137	138	140	142	144	146	148
		High Side	318	339	362	385	410	436	462	489	517	546	576	614
	80/67	Low Side	137	139	141	142	144	146	148	150	152	154	156	158
		High Side	326	348	371	395	420	447	474	502	530	560	591	630
	85/72	Low Side	142	144	146	147	149	151	153	155	157	159	161	--*
		High Side	337	360	384	409	435	463	491	520	549	580	612	--*

Low side pressure ± 4 PSIG

High side pressure ± 10 PSIG

Tables are based upon rated CFM (airflow) across the evaporator coil. If there is any doubt as to correct operating charge being in the system, the charge should be removed and system evacuated and recharged to serial plate charge weight.

NOTE: Pressure table based on high speed condenser fan operation. If condensing pressures appear elevated check condenser fan wiring. See "Condenser Fan Operation".

* Operating at these conditions would be outside the compressor operating envelope and is not recommended.

TABLE 11
Electrical Specifications – WAB Series**

MODEL	Rated Volts & Phase	No. Field Power Circuits	Single Circuit				Multiple Circuit													
			③ Minimum Circuit Ampacity	① Maximum External Fuse or Ckt. Brkr.	② Field Power Wire Size	② Ground Wire	③ Minimum Circuit Ampacity			① Maximum External Fuse or Ckt. Breaker			② Field Power Wire Size			② Ground Wire Size				
							Ckt. A	Ckt. B	Ckt. C	Ckt. A	Ckt. B	Ckt. C	Ckt. A	Ckt. B	Ckt. C	Ckt. A	Ckt. B	Ckt. C		
W18AB-A00, A0Z A05 A08 A10	230/208-1	1 1 1 1	16 30 45 56	20 30 45 60	12 10 8 6	12 10 10 10														
W24AB-A00, A0Z A05 A08 A10	230/208-1	1 1 1 1	21 30 46 56	30 35 50 60	10 8 8 6	10 10 10 10														
W24AB-B00, B0Z B06	230/208-3	1 1	15 22	20 25	12 10	14 10														
W24AB-C00, C0Z C06	460-3	1 1	8 11	10 15	14 14	14 14														
W30AB-A00, A0Z A05 A08 A10 A15	230/208-1	1 1 1 1 1 or 2	23 31 46 57 83	35 35 50 60 90	8 8 8 6 4	10 10 10 10 8	57	26		60	30		6	10			10	10		
W30AB-B00, B0Z B06 B09 B15	230/208-3	1 1 1 1	17 23 32 50	20 25 35 50	12 10 8 8	12 10 10 10														
W30AB-C00, C0Z C06 C09 C15	460-3	1 1 1 1	9 12 16 24	10 15 25 30	14 14 12 10	14 14 12 10														
W36AB-A00, A0Z A05 A08 A10 A15	230/208-1	1 1 1 1 1 or 2	27 32 48 58 84	35 35 50 60 90	8 8 8 6 4	10 10 10 10 8	58	26		60	30		6	10			10	10		
W36AB-B00, B0Z B06 B09 B15	230/208-3	1 1 1 1	20 24 33 51	25 30 35 60	10 10 8 6	10 10 10 10														
W36AB-C00, C0Z C06 C09 C15	460-3	1 1 1 1	10 11 15 24	10 15 15 25	14 14 14 10	14 14 14 10														

① Maximum size of the time delay fuse or circuit breaker for protection of field wiring conductors.

② Based on 75°C copper wire. All wiring must conform to the National Electrical Code and all local codes.

③ These “Minimum Circuit Ampacity” values are to be used for sizing the field power conductors. Refer to the National Electrical code (latest version), Article 310 for power conductor sizing.

CAUTION: When more than one field power circuit is run through one conduit, the conductors must be derated. Pay special attention to Note 8 of Table 310 regarding Ampacity Adjustment Factors when more than three current carrying conductors are in a raceway.

IMPORTANT: While this electrical data is presented as a guide, it is important to electrically connect properly sized fuses and conductor wires in accordance with the National Electrical Code and all local codes.

Setting Unit Airflow

The unit is set from the factory at the rated speed. Most units have three selectable speed taps that can be utilized. The rated speed is the lowest speed. The two higher speed taps can be used for higher duct static applications so that the unit can maintain the recommended airflow as shown in Table 13. The higher speeds can also be used when higher sensible cooling is desired. To change to the higher speed taps, move the orange/black wire on the blower speed terminal block (purple wire on some models) to either MED or HI. Refer to Table 14 on page 28 for the corresponding airflow of each tap. In the case of the units with a purple wire, only one higher speed tap is available (MED).

NOTE: Be sure to adjust the system static or blower speed to maintain airflows above the minimum recommendations to prevent freeze up conditions if Balanced Climate mode is activated.

Do not operate the unit in Balanced Climate mode if running high static applications as indicated in the blower performance table. If Balanced Climate mode is activated as described on page 18, the unit will run in this mode at all times unless there is a call for ventilation or electric heat. At that time, the unit will automatically activate a higher speed tap.

TABLE 13
Recommended Airflow

Model	Nominal Rated CFM*	Nominal Rated ESP*	Recommended Airflow Range	Factory Speed Connection	Minimum Airflow: Balanced Climate Mode
W18A, W18L	600	.10	550 - 725	Rated	380
W24A, W24L	800	.10	700 - 950		500
W30A, W30L	950	.15	900 - 1125		605
W36A, W36L	1150	.15	1000 - 1200		685

* Rated CFM and ESP on factory speed connection.

TABLE 14
Indoor Blower Performance

	E.S.P. (In. H ₂ O)	Balanced Climate™ Speed		Rated/Ventilation Speed*		MED Speed		HI Speed	
		Dry Coil	Wet Coil	Dry Coil	Wet Coil	Dry Coil	Wet Coil	Dry Coil	Wet Coil
W18AB/W18LB	0.00	520	510	680	665	865	855	SPEED NOT AVAILABLE	
	0.10	435	420	615	600	810	800		
	0.15	395	380	585	565	785	770		
	0.20	DO NOT OPERATE HERE		555	535	760	745		
	0.25			525	510	735	720		
	0.30			495	480	710	695		
	0.40			440	425	665	650		
	.050			385	375	620	605		
W24AB/W24LB	0.00	630	625	890	835	1005	980	1025	1035
	0.10	580	565	825	800	960	930	990	980
	0.15	550	535	795	780	935	910	975	955
	0.20	525	500	770	755	910	885	955	930
	0.25	DO NOT OPERATE HERE		740	730	890	865	935	910
	0.30			715	705	870	840	915	885
	0.40			670	650	825	805	870	845
	.050			630	585	785	765	825	805
W30AB/W30LB	0.00	830	825	1050	1020	1170	1135	1200	1205
	0.10	765	745	1000	975	1120	1105	1170	1155
	0.15	730	705	975	950	1095	1085	1150	1130
	0.20	700	670	950	925	1070	1060	1130	1105
	0.25	665	635	920	900	1050	1040	1110	1080
	0.30	630	605	890	870	1025	1015	1085	1055
	0.40	DO NOT OPERATE HERE		830	815	975	955	1040	1000
	.050			770	755	930	890	985	945
W36AB/W36LB	0.00	925	900	1255	1225	1365	1345	1495	1480
	0.10	850	825	1205	1175	1320	1300	1445	1425
	0.15	815	790	1180	1150	1295	1275	1415	1395
	0.20	780	755	1155	1125	1275	1250	1385	1360
	0.25	740	720	1130	1100	1250	1220	1350	1320
	0.30	700	685	1100	1070	1225	1195	1310	1280
	0.40	DO NOT OPERATE HERE		1050	1015	1180	1140	1225	1185
	.050			1000	960	1130	1075	1130	1075

* This is the speed set at the factory.

TABLE 15
Maximum ESP of Operation
Electric Heat Only

Model	W18A/L, W24A/L	W30A/L, W36A/L	
Outlet	FRONT	FRONT	
Speed	Single	High	Low
-A0Z	.50	.50	.50
-A05	.50	.50	.50
-A08	.50	.50	.50
-A10	.30	.40	.35
-A15		.40	.35
-B0Z	.50	.50	.50
-B06	.40	.50	.40
-B09		.50	.50
-B15		.35	.30
-C0Z	.50	.50	.50
-C06	.50	.50	.50
-C09		.50	.40
-C15		.45	.35

Values shown are for units equipped with standard 1" throwaway filter or 1" washable filter.

Derate ESP by .15 for 2" pleated filters.

TABLE 16
Electric Heat

Models	240V-1		208V-1		240V-3		208V-3		460V-3		
	KW	Amps	BTUH	Amps	BTUH	Amps	BTUH	Amps	BTUH	Amps	BTUH
5		20.8	17065	18.1	12800						
6						14.4	20500	12.5	15360	7.2	20500
8		33.3	27300	28.8	20475						
9						21.7	30600	18.7	23030	10.8	30700
10		41.6	34130	36.2	25600						
15		62.5	51250	54.0	38400	36.2	51200	31.2	38400	18.0	51200

TABLE 17
Vent and Control Options

Part Number	Description	W18, W24	W30, W36
CMA-14	ODT	X	X
CMC-15	Start Kit (230V 1-Phase)	X	X
CMC-31	Dirty Filter Sensor Kit	X	X
CMA-37	LAC - Modulating (230V)	X	
CMA-38	LAC - Modulating (460V)	X	
CMA-39	LAC - On/Off		X
CMA-40	DDC	X	X
BOP-2	Blank Off Plate	X	
FAD-NE2	Fresh Air Damper - No Exhaust	X	
FAD-BE2	Fresh Air Damper - Barometric Exhaust	X	
CRVF-2	Commercial Ventilator - On/Off, Spring Return	X	
CRVV-2	Commercial Ventilator - 0-10V, Spring Return	X	
ECONNC-2	Economizer - Bldg. Equipment, 0-10V, No Controls	X	
ECONS-2	Economizer - School	X	
ECONWD-2	Economizer - Bldg. Equipment, Enthalpy or Temperature	X	
BOP3	Blank Off Plate		X
FAD-NE3	Fresh Air Damper - No Exhaust		X
FAD-BE3	Fresh Air Damper - Barometric Exhaust		X
CRVF-3	Commercial Ventilator - On/Off, Spring Return		X
CRVV-3	Commercial Ventilator - 0-10V, Spring Return		X
ECONNC-3	Economizer - Bldg. Equipment, 0-10V, No Controls		X
ECONS-3	Economizer - School		X
ECONWD-3	Economizer - Bldg. Equipment, Enthalpy or Temperature		X

TABLE 18A
Optional Accessories – Right Hand

		W18AB-A	W24AB-A	W24AB-B	W24AB-C	W30AB-A	W30AB-B	W30AB-C	W36AB-A	W36AB-B	W36AB-C	
Heater Kits	EHW1TAB-A05	X										
	EHW1TAB-A08	X										
	EHW2TAB-A05		X									
	EHW2TAB-A08		X									
	EHW2TA-A10	X	X									
	EHW2TA-B06			X								
	EHWH24B-C06				X							
	EHW3TA-A05					X			X			
	EHW3TA-A08					X			X			
	EHW3TA-A10					X						
	EHW3TAB-A10								X			
	EHW3TA-A15								X			
	EHW3TAB-A15					X						
	EHW30A-B06						X					
	EHW3TA-B06									X		
	EHW3TA-B09						X					
	EHW3TAB-B09									X		
	EHW3TA-B15									X		
	EHW3TAB-B15						X					
	EHW3TA-C06							X			X	
	EHW3TA-C09							X			X	
	EHW3TA-C12							X			X	
	EHW3TA-C15										X	
	EHW3TAB-C15							X				
	Circuit Breaker (WMCB) and Pull Disconnect (WMPD)	WMCB-01B			X							
		WMCB-02A	X									
WMCB-02B							X					
WMCB-03A			X									
WMCB-04B										X		
WMCB-05A						X			X			
WMPD-01C					X			X			X	

TABLE 18B
Optional Accessories – Left Hand

		W18LB-A	W24LB-A	W24LB-B	W30LB-A	W30LB-B	W30LB-C	W36LB-A	W36LB-B	W36LB-C
Heater Kits	EHW1TAB-A05L	X								
	EHW1TAB-A08L	X								
	EHW2TA-A05L		X							
	EHW2TA-A08L		X							
	EHW2TA-A10L	X	X							
	EHW2TA-B06L			X						
	EHW3TA-A05L				X			X		
	EHW3TA-A08L				X					
	EHW3TA-A10L				X					
	EHW3TAB-A10L							X		
	EHW3TA-A15L							X		
	EHW3TAB-A15L				X					
	EHW3TA-B09L					X				
	EHW3TAB-B09L								X	
	EHW3TA-B15L								X	
	EHW3TAB-B15L					X				
	EHW3TA-C09L						X			X
	EHW3TA-C15									X
	EHW3TA-C15L									X
	EHW3TAB-C15L						X			
Circuit Breaker (WMCB) and Pull Disconnect (WMPD)	WMCB-01B			X						
	WMCB-02A	X								
	WMCB-02B					X				
	WMCB-03A		X							
	WMCB-04B								X	
	WMCB-05A				X			X		
	WMPD-01C						X			X