INSTALLATION INSTRUCTIONS

Wall Mount Energy Recovery Ventilator with Exhaust

Models:

ERV-FA2 ERV-FC2

ERV-FA3 ERV-FC3

For Use with Bard 1.5 – 3 Ton
Wall Mount Air Conditioners and Heat Pumps



Bard Manufacturing Company, Inc.
Bryan, Ohio 43506
www.bardhvac.com

Manual: 2100-701D
Supersedes: 2100-701C
Date: 6-8-23

CONTENTS

Model Nomenclature.....	3
Electrical Specifications.....	3
General Information	3
Field-Supplied Tools Needed	3
Unpacking	3
Description	3
Performance and Application Data – ERV-F*2	4
Performance and Application Data – ERV-F*3	5
Basic Field Installation.....	6
Control Wiring	11
Ventilation Airflow.....	11
Energy Recovery Ventilator Maintenance	14

Figures

Figure 1 Remove Access Panels	6
Figure 2 Remove Filter, Filter Support Bracket and Exhaust Cover Plate and Install Exhaust Damper Assembly	7
Figure 3 Install Ventilator	8
Figure 4 Install Low and High Voltage Plugs and Wiring.....	9
Figure 5 Install Fresh Air Intake Hood Assembly .	10
Figure 6 Speed Tap Label	12
Figure 7 Airflow Diagram	13
Figure 8 Belt Replacement Instructions	15
Figure 9 Hub Assembly with Ball Bearings	16

Tables

Table 1 Model Reference.....	6
Table 2 Ventilation Air.....	11

WARNING

Electrical shock hazard.
***Disconnect remote electrical power supply
or supplies before servicing.***
***Failure to do so could result in electric
shock or death.***

WARNING

Exposed moving parts.
***Disconnect electrical power before
servicing.***
***Failure to do so could result in severe
injury or amputation.***

CAUTION

Cut hazard.
***Wear gloves to avoid contact with sharp
edges.***
Failure to do so could result in personal injury.

Wall Mount Energy Recovery Ventilator Model Nomenclature

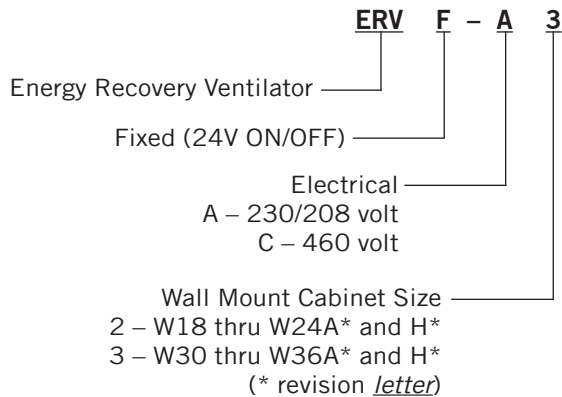

Electrical Specifications

Model	Voltage	Amps	Control Voltage
ERV-FA2 ERV-FA3	230/208	2.2	24V
ERV-FC2 ERV-FC3	460	1.2	24V

General Information

The ventilator should only be installed by a trained heating and air conditioning technician. These instructions serve as a guide to the technician installing the ventilator package. They are not intended as a step-by-step procedure with which the mechanically inclined owner can install the package.

The ventilator housing is shipped in one carton which contains the following:

- Energy recovery ventilator
- Exhaust damper assembly
- Service door
- Rain hood and mist eliminator
- Installation instructions

Field-Supplied Tools Needed

- Appropriate personal protection equipment, including gloves and safety glasses
- 5/16" nut driver
- Phillips head screwdriver
- Small flat head screwdriver for securing wire in terminal blocks
- Electrical tools
- Multimeter

Unpacking

Upon receipt of the equipment, be sure to compare the model number found on the shipping label with the accessory identification information on the ordering and shipping document to verify that the correct accessory has been shipped.

Inspect the carton housing of each ventilator as it is received and, before signing the freight bill, verify that all items have been received and that there is no visible damage. Note any shortages or damage on all copies of the freight bill. The receiving party must contact the last carrier immediately, preferably in writing, requesting inspection by the carrier's agent. Concealed damage not discovered until after loading must be reported to the carrier within 15 days of its receipt.

Description

The energy recovery ventilator was designed to provide energy efficient, cost effective ventilation to meet IAQ (indoor air quality) requirements while still maintaining good indoor comfort and humidity control for a variety of applications such as schools, classrooms, lounges, conference rooms, beauty salons and others. It provides a constant supply of fresh air for control of airborne pollutants including CO₂, smoke, radon, formaldehyde, excess moisture, virus and bacteria.

The ventilator incorporates rotary heat exchanger technology to remove both heat and moisture.

It is designed as a single package which can be easily factory or field installed for new installations or retrofit to the Bard W**A and W**H series wall-mounted units. The package consists of a unique rotary energy recovery cassette that can be easily removed for cleaning or maintenance. The ERV-F*3 has two 13" diameter heat transfer wheels whereas the ERV-F*2 has one 13" diameter heat transfer wheel. The heat transfer wheels use a permanently bonded dry desiccant coating for total heat recovery.

Ventilation is accomplished with two blower/motor assemblies each consisting of a drive motor and dual blowers for maximum ventilation at low sound levels. The intake and exhaust blowers can be operated at the same speed (airflow rate) or different speeds to allow flexibility in maintaining desired building pressurization conditions. Factory shipped on medium intake and low exhaust. See Figure 6 on page 12 to change speeds. The rotating energy wheels provide the heat transfer effectively during both summer and winter conditions. Provide required ventilation to meet the requirements of ASHRAE 62.1 standard.

NOTE: During operation below 5° F outdoor temperature, freezing of moisture in the heat transfer wheel can occur. Consult the factory if this possibility exists.

Performance and Application Data – ERV-F*2

Summer Cooling Performance (Indoor Design Conditions 75°DB/62°WB)

Ambient OD		Ventilation Rate 250 CFM 62% Efficiency						Ventilation Rate 225 CFM 63% Efficiency						Ventilation Rate 200 CFM 63% Efficiency					
DB/ WB	F	VLT	VLS	VLL	HRT	HRS	HRL	VLT	VLS	VLL	HRT	HRS	HRL	VLT	VLS	VLL	HRT	HRS	HRL
105	75	11925	8100	1325	79394	5022	822	10727	7287	3441	6758	4591	2168	9540	6480	3060	6010	4082	1928
	70	8100	8100	0	5022	5022	0	7287	7287	0	4591	4591	0	6480	6480	0	4082	4082	0
	65	8100	8100	0	5022	5022	0	7287	7287	0	4591	4591	0	6480	6480	0	4082	4082	0
100	80	17550	6750	10800	10881	4185	6696	15788	6072	9716	9946	3826	6121	14040	5400	8640	8845	3402	5443
	75	11925	6750	5175	7394	4185	3209	10727	6072	4655	6758	3826	2933	9540	5400	4140	6010	3402	2608
	70	6863	6750	113	4255	4185	70	6173	6072	101	3889	3826	64	5490	5400	90	3458	3402	56
	65	6750	6750	0	4185	4185	0	6072	6072	0	3826	3826	0	5400	5400	0	3402	3402	0
	60	6750	6750	0	4185	4185	0	6072	6072	0	3826	3826	0	5400	5400	0	3402	3402	0
95	80	17550	5400	12150	10881	3348	7533	15788	4858	10930	9946	3060	6886	14040	4320	9720	8845	2722	6124
	75	11925	5400	6525	7394	3348	4046	10727	4858	5870	6758	3060	3698	9540	4320	5220	6010	2722	3289
	70	6863	5400	1463	4255	3348	907	6173	4858	1315	3889	3060	829	5490	4320	1170	3458	2722	737
	65	5400	5400	0	3348	3348	0	4858	4858	0	3060	3060	0	4320	4320	0	2722	2722	0
	60	5400	5400	0	3348	3348	0	4858	4858	0	3060	3060	0	4320	4320	0	2722	2722	0
90	80	17550	4050	13500	10881	2511	8370	15788	3643	12145	9946	2295	7651	14040	3240	10800	8845	2041	6804
	75	11925	4050	7875	7394	2511	4883	10727	3643	7084	6758	2295	4463	9540	3240	6300	6010	2041	3969
	70	6863	4050	2813	4255	2511	1744	6173	3643	2530	3889	2295	1594	5490	3240	2250	3458	2041	1417
	65	4050	4050	0	2511	2511	0	3643	3643	0	2295	2295	0	3240	3240	0	2041	2041	0
	60	4050	4050	0	2511	2511	0	3643	3643	0	2295	2295	0	3240	3240	0	2041	2041	0
85	80	17550	2700	14850	10881	1674	9207	15788	2429	13359	9946	1530	8416	14040	2160	11880	8845	1361	7484
	75	11925	2700	9225	7394	1674	5720	10727	2429	8298	6758	1530	5228	9540	2160	7380	6010	1361	4649
	70	6863	2700	4163	4255	1674	2581	6173	2429	3744	3889	1530	2359	5490	2160	3300	3458	1361	2098
	65	2700	2700	0	1674	1674	0	2429	2429	0	1530	1530	0	2160	2160	0	1361	1361	0
	60	2700	2700	0	1674	1674	0	2429	2429	0	1530	1530	0	2160	2160	0	1361	1361	0
80	75	11925	1350	10575	7394	837	6557	10727	1214	9513	6758	765	5993	9540	1080	8460	6010	680	5330
	70	6863	1350	5513	4255	837	3418	6173	1214	4959	3889	765	3124	5490	1080	4410	3458	680	2778
	65	2363	1350	1013	1465	837	628	2125	1214	911	1339	765	574	1890	1080	810	1190	680	510
	60	1350	1350	0	837	837	0	1214	1214	0	765	765	0	1080	1080	0	680	680	0
75	70	6863	0	6863	4255	0	4255	6173	0	6173	6889	0	6889	5490	0	5490	3458	0	3458
	65	2363	0	2363	1465	0	1465	2125	0	2125	1339	0	1339	1890	0	1890	1190	0	1190
	60	0	0	0	0	0	0	0	0	0	0	0	0	0	0	0	0	0	0

Winter Heating Performance (Indoor Design Conditions 70°F DB)

Ambient OD	Ventilation Rate					
	250 CFM 74% Eff.		225 CFM 75% Eff.		200 CFM 75% Eff.	
DB/°F	WVL	WHR	WVL	WHR	WVL	WHR
65	1350	999	1214	911	1080	810
60	2700	1998	2429	1822	2160	1620
55	4050	2997	3643	2733	3240	2430
50	5400	3996	4858	3643	4320	3240
45	6750	4995	6072	4554	5400	4050
40	8100	5994	7287	5465	6480	4860
35	9450	6993	8501	6376	7560	5670
30	10800	7992	9716	7287	8640	6480
25	12150	8991	10930	8198	9720	7290
20	13500	9990	12145	9108	10800	8100
15	14850	10989	13359	10019	11880	8910

LEGEND:

- VLT = Ventilation Load – Total
- VLS = Ventilation Load – Sensible
- VLL = Ventilation Load – Latent
- HRT = Heat Recovery – Total
- HRS = Heat Recovery – Sensible
- HRL = Heat Recovery – Latent
- WVL = Winter Ventilation Load
- WHR = Winter Heat Recovery

NOTE: All performance data is based on operating intake and exhaust blower on the same speed.

Performance and Application Data – ERV-F*3

Summer Cooling Performance (Indoor Design Conditions 75°DB/62°WB)

Ambient OD		Ventilation Rate 400 CFM 63% Efficiency						Ventilation Rate 325 CFM 64% Efficiency						Ventilation Rate 250 CFM 65% Efficiency					
DB/ WB	F	VLT	VLS	VLL	HRT	HRS	HRL	VLT	VLS	VLL	HRT	HRS	HRL	VLT	VLS	VLL	HRT	HRS	HRL
105	75	19080	12960	6120	12020	8164	3855	15502	10530	4972	9921	6739	3182	11925	8100	3825	7751	5265	2486
	70	12960	12960	0	8164	8164	0	10530	10530	0	6739	6739	0	8100	8100	0	5265	5265	0
	65	12960	12960	0	8164	8164	0	10530	10530	0	6739	6739	0	8100	8100	0	5265	5265	0
100	80	29080	10800	17280	17690	6804	10886	22815	8775	14040	14601	5616	8985	17550	6750	10800	11407	4387	7019
	75	19080	10800	8280	12020	6804	5216	15502	8775	6727	9921	5616	4305	11925	6750	5175	7751	4387	3363
	70	10980	10800	180	6717	6804	113	8921	8775	146	5709	5616	93	6862	6750	112	4460	4387	73
	65	10800	10800	0	6804	6804	0	8775	8775	0	5616	5616	0	6750	6750	0	4387	4387	0
	60	10800	10800	0	6804	6804	0	8775	8775	0	5616	5616	0	6750	6750	0	4387	4387	0
95	80	28080	8640	19440	17690	5443	12247	22815	7020	15795	14601	4492	10108	17550	5400	12150	11407	3510	7897
	75	19080	8640	10440	12020	5443	6577	15502	7020	8482	9921	4492	5428	11925	5400	6525	7751	3510	4241
	70	10980	8640	2340	6917	5443	1474	8921	7020	1901	5709	4492	1216	6862	5400	1462	4460	3510	950
	65	8640	8640	0	5443	5443	0	7020	7020	0	4492	4492	0	5400	5400	0	3510	3510	0
	60	8640	8640	0	5443	5443	0	7020	7020	0	4492	4492	0	5400	5400	0	3510	3510	0
90	80	28080	6480	21600	17690	4082	13608	22815	5265	17550	14601	3369	11232	17550	4050	13500	11407	2632	8774
	75	19080	6480	12600	12020	4082	7938	15502	5265	10237	9921	3369	6552	11925	4050	7875	7751	2632	5118
	70	10980	6480	4500	6917	4082	2835	8921	5265	3656	5709	3369	2340	6862	4050	2812	4460	2632	1828
	65	6480	6480	0	4082	4082	0	5265	5265	0	3369	3369	0	4050	4050	0	2632	2632	0
	60	6480	6480	0	4082	4082	0	5265	5265	0	3369	3369	0	4050	4050	0	2632	2632	0
85	80	28080	4320	23760	17690	2721	14968	22815	3510	19305	14601	2246	12355	17550	2700	14850	11407	1755	9652
	75	19080	4320	14760	12020	2721	9298	15502	3510	11992	9921	2246	7675	11925	2700	9225	7751	1755	5996
	70	10980	4320	6660	6917	2721	4195	8921	3510	5411	5709	2246	3463	6862	2700	4162	4460	1755	2705
	65	4320	4320	0	2721	2721	0	3510	3510	0	2246	2246	0	2700	2700	0	1755	1755	0
	60	4320	4320	0	2721	2721	0	3510	3510	0	2246	2246	0	2700	2700	0	1755	1755	0
80	75	19080	2160	16920	12020	1360	10659	15502	1755	13747	9921	1123	8798	11925	1350	10575	7751	877	6873
	70	10980	2160	8820	6917	1360	5556	8921	1755	7166	5709	1123	4586	6862	1350	5512	4460	877	3583
	65	3780	2160	1620	2381	1360	1020	3071	1755	1316	1965	1123	842	2362	1350	1012	1535	877	658
60	2160	2160	0	1360	1360	0	1755	1755	0	1123	1123	0	1350	1350	0	877	877	0	
75	75	10980	0	10980	6917	0	6917	8921	0	8921	5709	0	5709	6862	0	6862	4460	0	4460
	65	3780	0	3780	2381	0	2380	3071	0	3071	1965	0	1965	2362	0	2362	1535	0	1535
	60	0	0	0	0	0	0	0	0	0	0	0	0	0	0	0	0	0	0

Winter Heating Performance (Indoor Design Conditions 70°F DB)

Ambient OD	Ventilation Rate					
	400 CFM 75% Eff.		325 CFM 76% Eff.		250 CFM 77% Eff.	
DB/°F	WVL	WHR	WVL	WHR	WVL	WHR
65	2160	1620	1755	1333	1350	1039
60	4320	3240	3510	2667	2700	2079
55	6480	4860	5265	4001	4050	3118
50	8640	6480	7020	5335	5400	4158
45	10800	8100	8775	6669	6750	5197
40	12960	9720	10530	8002	8100	6237
35	15120	11340	12285	9336	9450	7276
30	17280	12960	14040	10670	10800	8316
25	19440	14580	15795	12004	12150	9355
20	21600	16200	17550	13338	13500	10395
15	23760	17820	19305	14671	14850	11434

LEGEND:

- VLT = Ventilation Load – Total
- VLS = Ventilation Load – Sensible
- VLL = Ventilation Load – Latent
- HRT = Heat Recovery – Total
- HRS = Heat Recovery – Sensible
- HRL = Heat Recovery – Latent
- WVL = Winter Ventilation Load
- WHR = Winter Heat Recovery

NOTE: All performance data is based on operating intake and exhaust blower on the same speed.

Basic Field Installation

1. Unpack the ventilator assembly which includes the integral ventilator with attached electrical harness and miscellaneous hardware.

⚠ WARNING

Open and lock unit disconnect switch before installing this accessory to prevent injury or death due to electrical shock or contact with moving parts. Turn thermostat to OFF.

2. Disconnect unit power.
3. Remove the existing exterior blower access, filter access and vent option panels on the wall-mount unit (see Figure 1). Save the blower access and filter access panels and discard the vent option panel.

TABLE 1
Model Reference

Model	For Use with the Following Units		Electrical
ERV-FA2	W18AB-A W18AY-A W24AB-A, -B W24AY-A, -B	W18HB-A W18HY-A W24HB-A, -B W24HY-A, -B	230/208V 1 or 3 phase
ERV-FC2	W24AB-C W24AY-C	W24HB-C W24HY-C	460V 3 phase
ERV-FA3	W30AB-A, -B W30AY-A, -B W36AB-A, -B W36AY-A, -B	W30HB-A, -B W30HY-A, -B W36HB-A, -B W36HY-A, -B	230/208V 1 or 3 phase
ERV-FC3	W30AB-C W30AY-C W36AB-C W36AY-C	W30HB-C W30HY-C W36HB-C W36HY-C	460ERV-F 3 phase

FIGURE 1
Remove Access Panels

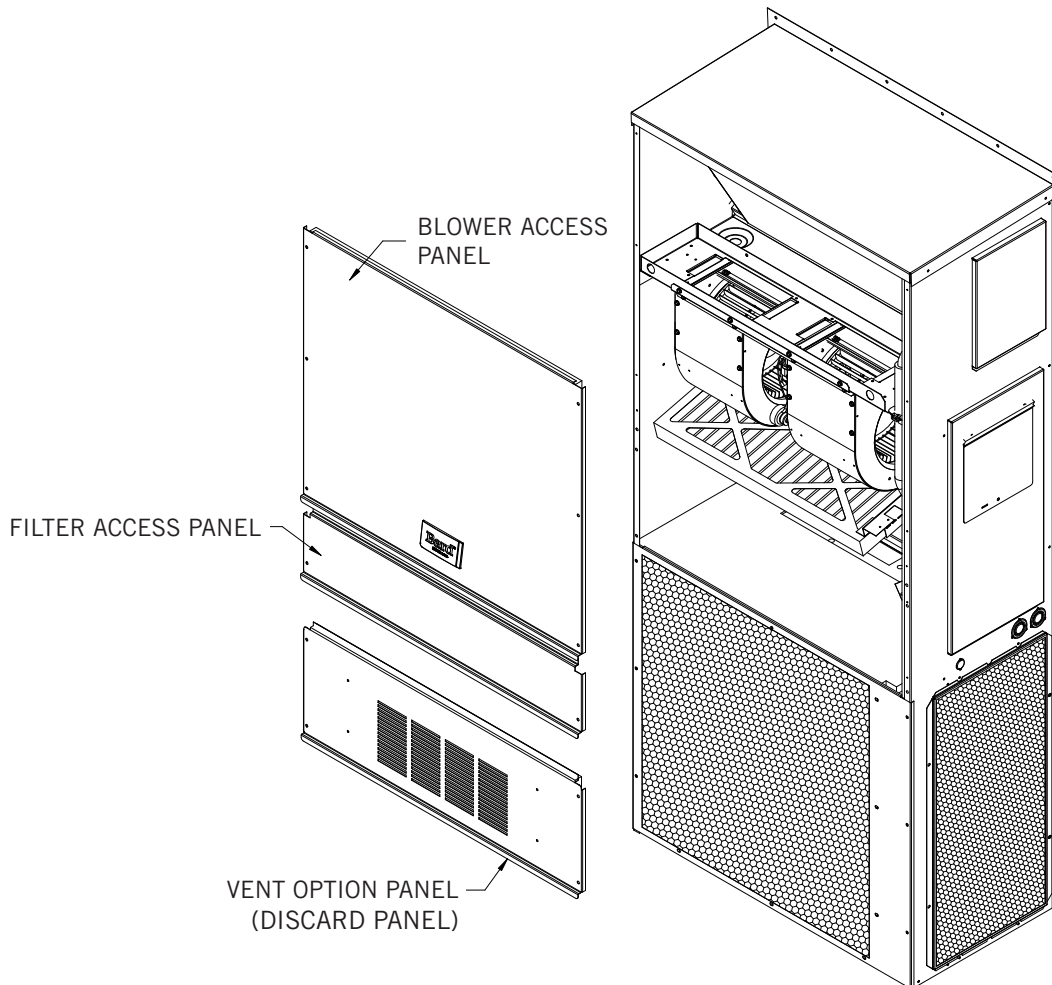

MIS-344A

CAUTION

Be sure the correct model and voltage energy recovery ventilator is used with the correct air conditioner or heat pump to ensure correct voltage compatibility.

4. Verify what type of filter racks are in the unit. Unit may include either a filter partition and tray assembly, or two separate filter brackets. If the unit contains two separate filter brackets, remove and

save existing unit return air filter. Remove left-side filter support bracket by unscrewing two (2) screws from left side of unit. Remove and save top four (4) screws from front grille (see Figure 2). If the unit contains a partition and tray assembly, this may be left as-is for the ventilator installation.

5. Remove and discard exhaust cover plate (see Figure 2). Re-install left filter bracket, if applicable: Install W18 and W24 brackets as shipped; install W30 and W36 brackets straight. **W30 and W36 Models Only:** Install the filter fill on the top rear of the filter bracket. Bend up and fasten with two (2) self-drilling screws.

FIGURE 2
Remove Filter, Filter Support Bracket and Exhaust Cover Plate

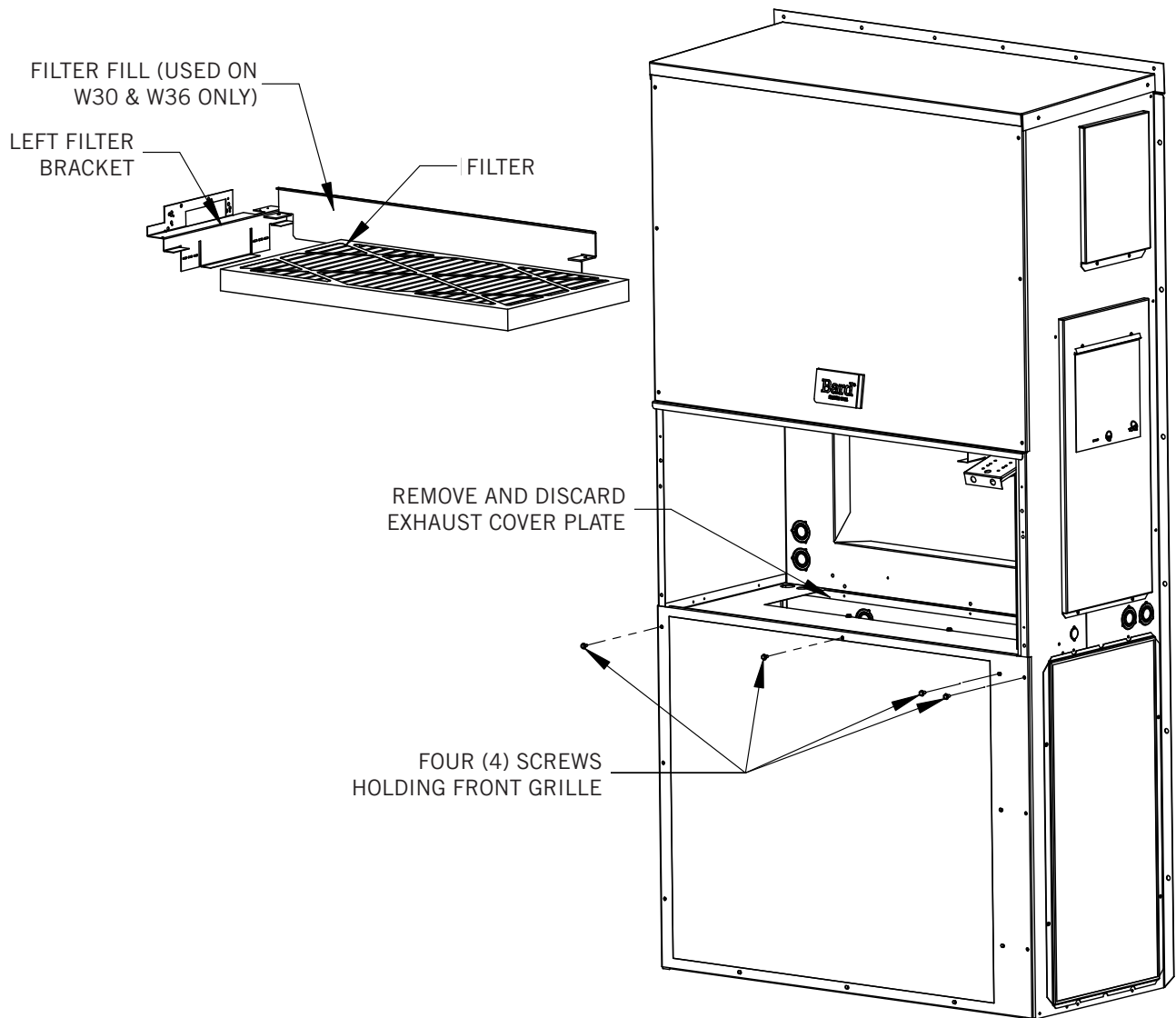

MIS-4003

- Insert ventilator into the unit to the far left side, making sure to clear the right filter bracket. Once the ventilator is fully inserted, slide the ventilator to the right until it is tight against the back of the control panel (see Figure 3).

IMPORTANT NOTE: Position front lip of ventilator over front grille and on top of condenser partition (see Figure 3 inset). This is important to ensure proper drainage of any water entering damper assembly.

- Re-install left side filter support bracket, filter fill and air filter removed during Step 4, if applicable (see Figure 2).
- Remove outer and inner control panel covers.
- Remove female plug of high voltage wiring harness (3-pin plug) from the heat recovery assembly and snap into unit control panel (from inside control panel) in the hole provided. Wire to top of compressor contactor (L1/L2) per Figure 4. Connect high voltage plugs back together (see Figures 3 and 4).

FIGURE 3
Install Ventilator

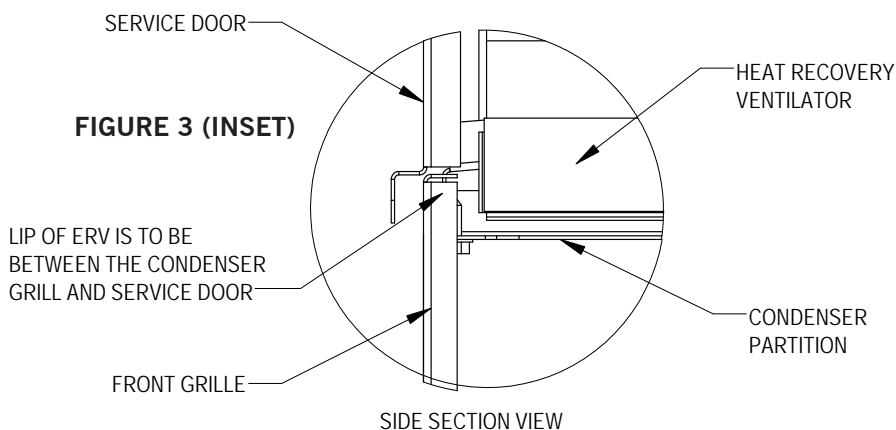
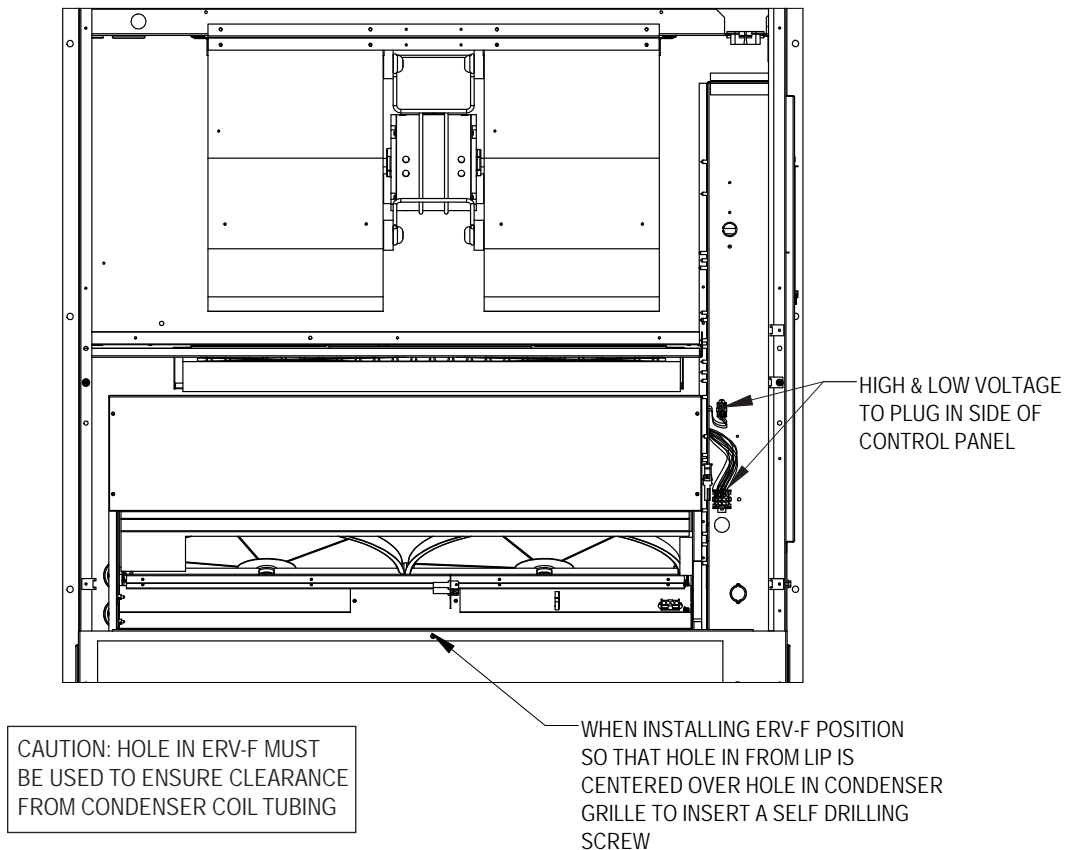

MIS-4004

10. Plug low voltage plug (12-pin plug) from the heat recovery unit into the front side of the control panel (see Figures 3 and 4).

NOTE: These 24 volt control wires control the starting and stopping of the energy recovery ventilator and can be independently controlled by an energy management control or timer. See **Control Wiring** on page 11.

11. Replace inner and outer control panel covers.

12. Ventilator checkout

A. Resupply power to unit.

B. Energize the "A" occupancy 24 volt signal on the low voltage terminal strip (jumper "R" to "A").

FIGURE 4
Install Low and High Voltage Plugs and Wiring

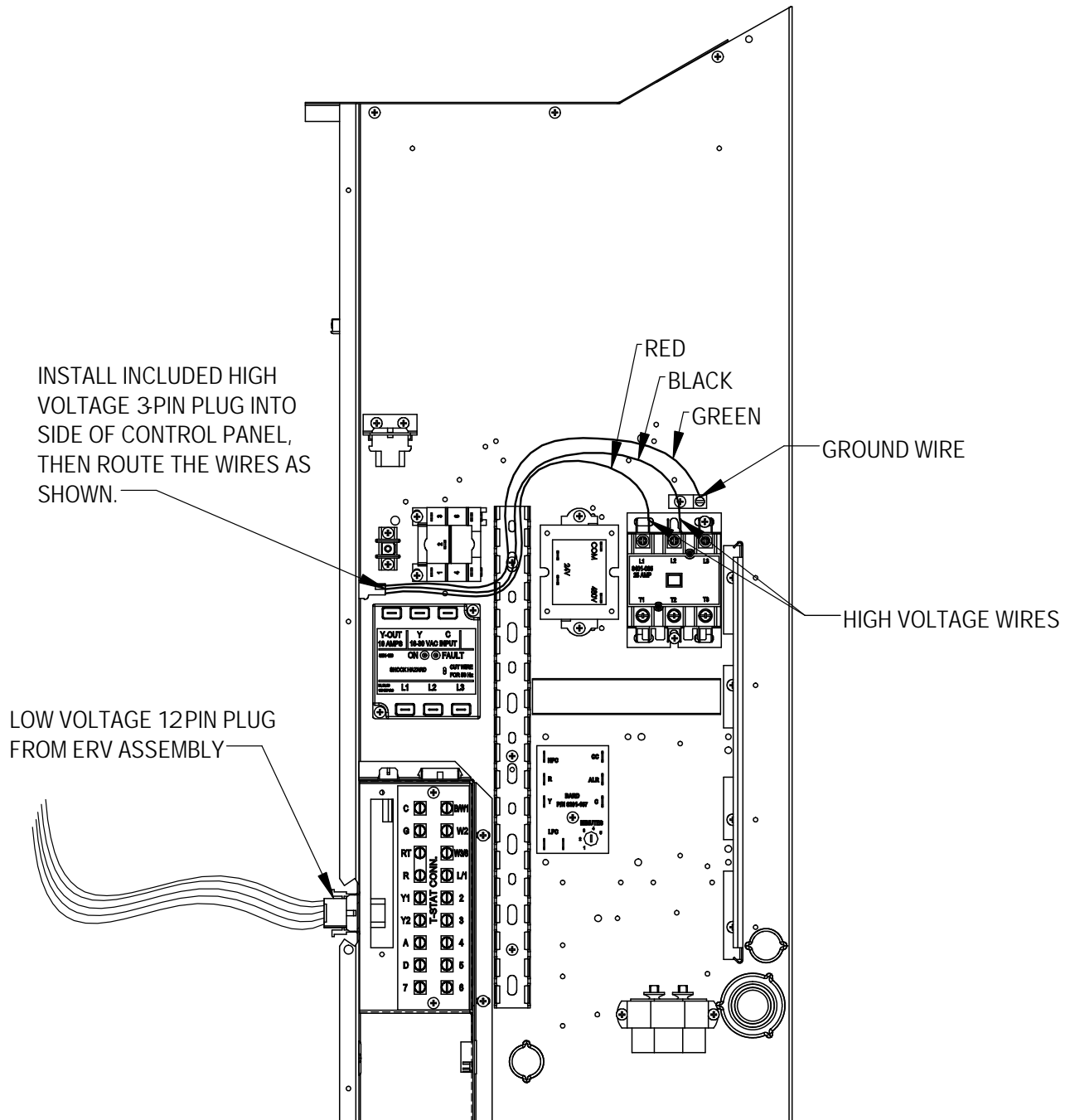

MIS-3776A

- C. Ventilator heat transfer wheels should rotate slowly (49 RPM). Intake and exhaust blowers should run and indoor comfort blower should run.
 - D. De-energize the "A" terminal. The energy recovery wheels, fresh air, exhaust air and indoor comfort blowers should stop.
 - E. This completes ventilator checkout.
13. Re-install the blower access and filter access panels at top of unit and secure with sheet metal screws.
 14. Replace the vent option access panel with the new panel provided. Attach air intake hood with screws provided (see Figure 5). Be sure to insert the top flange of the air intake hood into and through the slot of the service door and between the door and insulation to prevent bowing of the door.
 15. Apply certification label, included with installation instructions, next to unit serial plate.
 16. Ventilator is now ready for operation.

FIGURE 5
Install Fresh Air Intake Hood Assembly

INSERT FLANGE THRU SLOT IN DOOR AND
PUSH FLANGE UNDER INSULATION

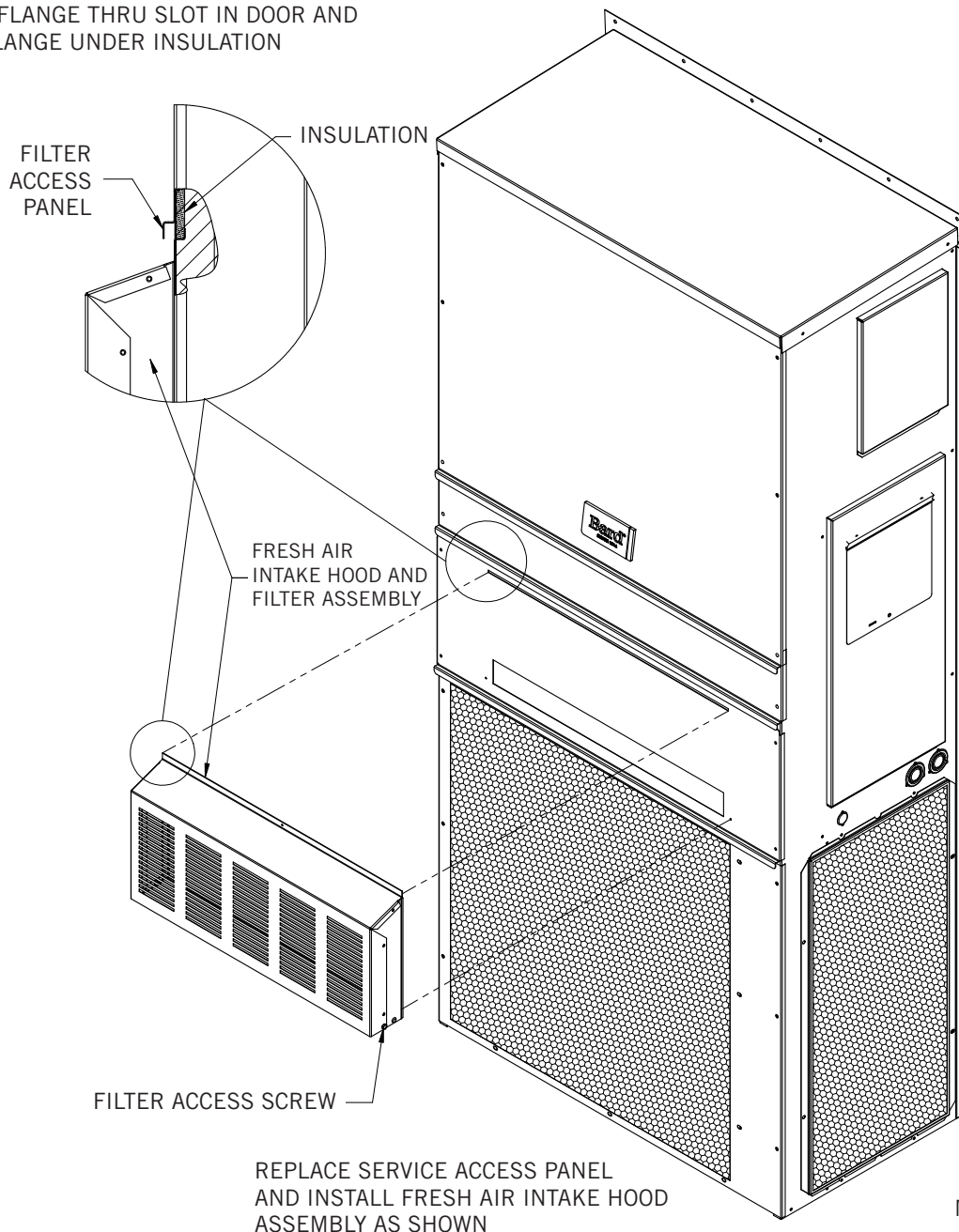

Control Wiring

The ERV-F comes from the factory with the low voltage control wires connected to the wall mount low voltage terminal strip. Care must be taken when deciding how to control the operation of the ventilator. When designing the control circuit for the ventilator, the following requirements must be met.

Control Requirements

1. Indoor blower motor will automatically run whenever the ERV-F is run.
2. Select the correct motor speed tap in the ERV-F. Using Table 2, determine the motor speed needed to get the desired amount of ventilation air needed. For instance, do not use the high speed tap on a ERV-F*3 if only 250 CFM of ventilation air is needed. Use the low speed tap instead (see **VENTILATION AIRFLOW** for information on moving the speed taps). Using the high speed tap would serve no useful purpose and significantly affect the overall efficiency of the air conditioning system. System operating cost would also increase.

TABLE 2
Ventilation Air (CFM)

Model	High Speed (Black)	Medium Speed (Blue)	Low Speed (Red)
ERV-FA2 ERV-FC2	250	225	200
ERV-FA3 ERV-FC3	400	325	250

3. Run the ERV-F only during periods when the conditioned space is occupied. Running the ERV-F during unoccupied periods wastes energy, decreases the expected life of the ERV-F and can result in a large moisture buildup in the structure. The ERV-F removes 60-70% of the moisture in the incoming air, not 100% of it. Running the ERV-F when the structure is unoccupied allows moisture to build up in the structure because there is little or no cooling load. Thus, the air conditioner is not running enough to remove the excess moisture being brought in. Use a control system that in some way can control the system based on occupancy.

IMPORTANT

Operating the ERV-F during unoccupied periods can result in a buildup of moisture in the structure.

Recommended Control Sequences

Several possible control scenarios are listed below:

1. Use a programmable electronic thermostat with auxiliary terminal to control the ERV-F based on daily programmed occupancy periods. Bard markets and recommends Bard Part No. 8403-060 programmable electronic thermostat for air conditioner and heat pump applications.
2. Use a motion sensor in conjunction with a mechanical thermostat to determine occupancy in the structure. Bard recommends Bard Model CS9B*-* CompleteStat for this application.
3. Use a CO₂ control with dry contacts to energize the ERV-F when CO₂ levels rise above desired settings.
4. Use a DDC control system to control the ERV-F based on a room occupancy schedule to control the ERV-F.
5. Tie the operation of the ERV-F into the light switch. The lights in a room are usually on only when occupied.
6. Use a manual timer that the occupants turn to energize the ERV-F for a specific number of hours.
7. Use a programmable mechanical timer to energize the ERV-F and indoor blower during occupied periods of the day.

Ventilation Airflow

The ERV-FA* and ERV-FC* are equipped with a 3-speed motor to provide the capability of adjusting the ventilation rates to the requirements of the specific application by changing motor speeds (see Table 2).

WARNING

Open disconnect to shut all power OFF before changing motor speeds. Failure to do so could result in injury or death due to electrical shock.

The units are set from the factory with the exhaust blower on the low speed and the intake blower on medium speed. Moving the speed taps located in the control panel can change the blower speed of the intake and exhaust (see Figure 6 on page 12).

NOTE: No setup changes required to operate in *Balanced Climate™* mode.

FIGURE 6
Speed Tap Label

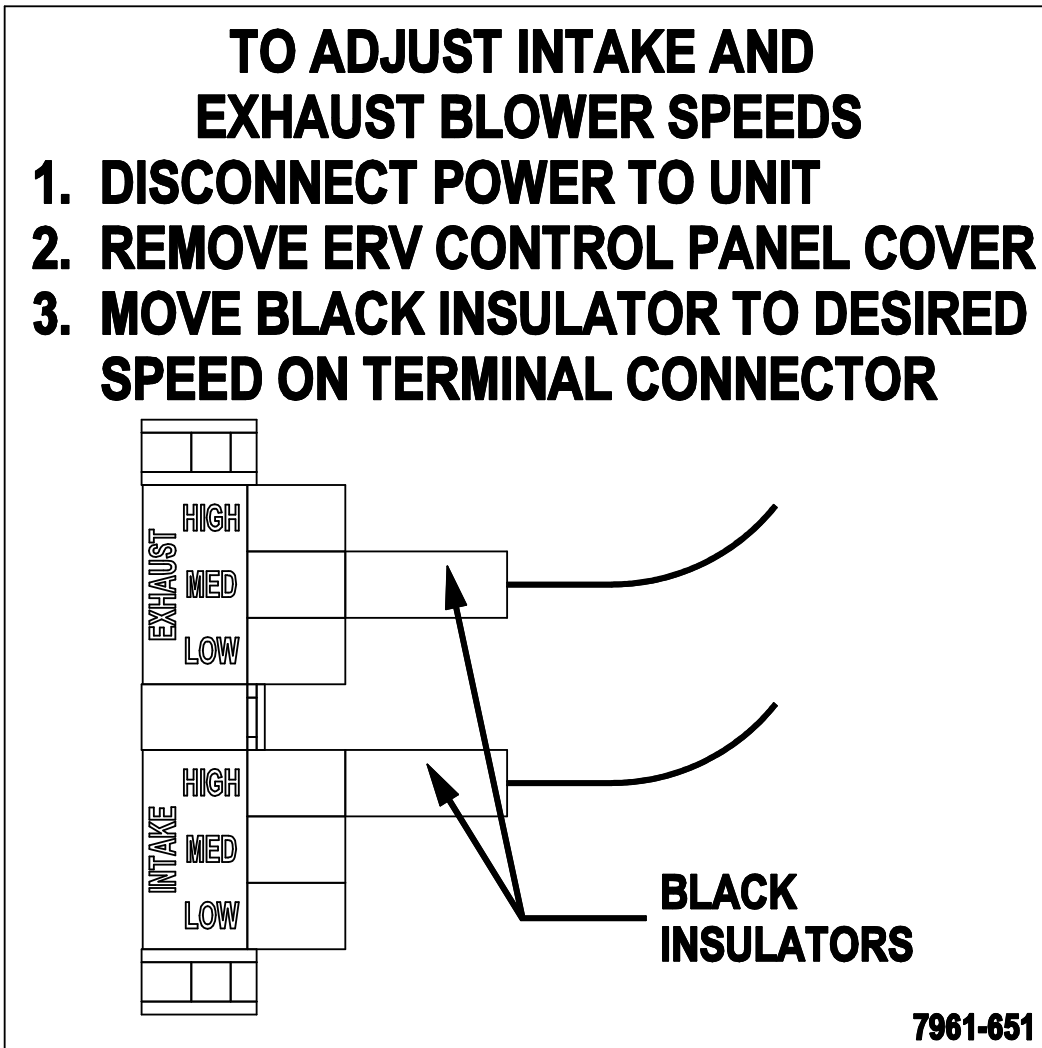

MIS-2120

FIGURE 7
Airflow Diagram

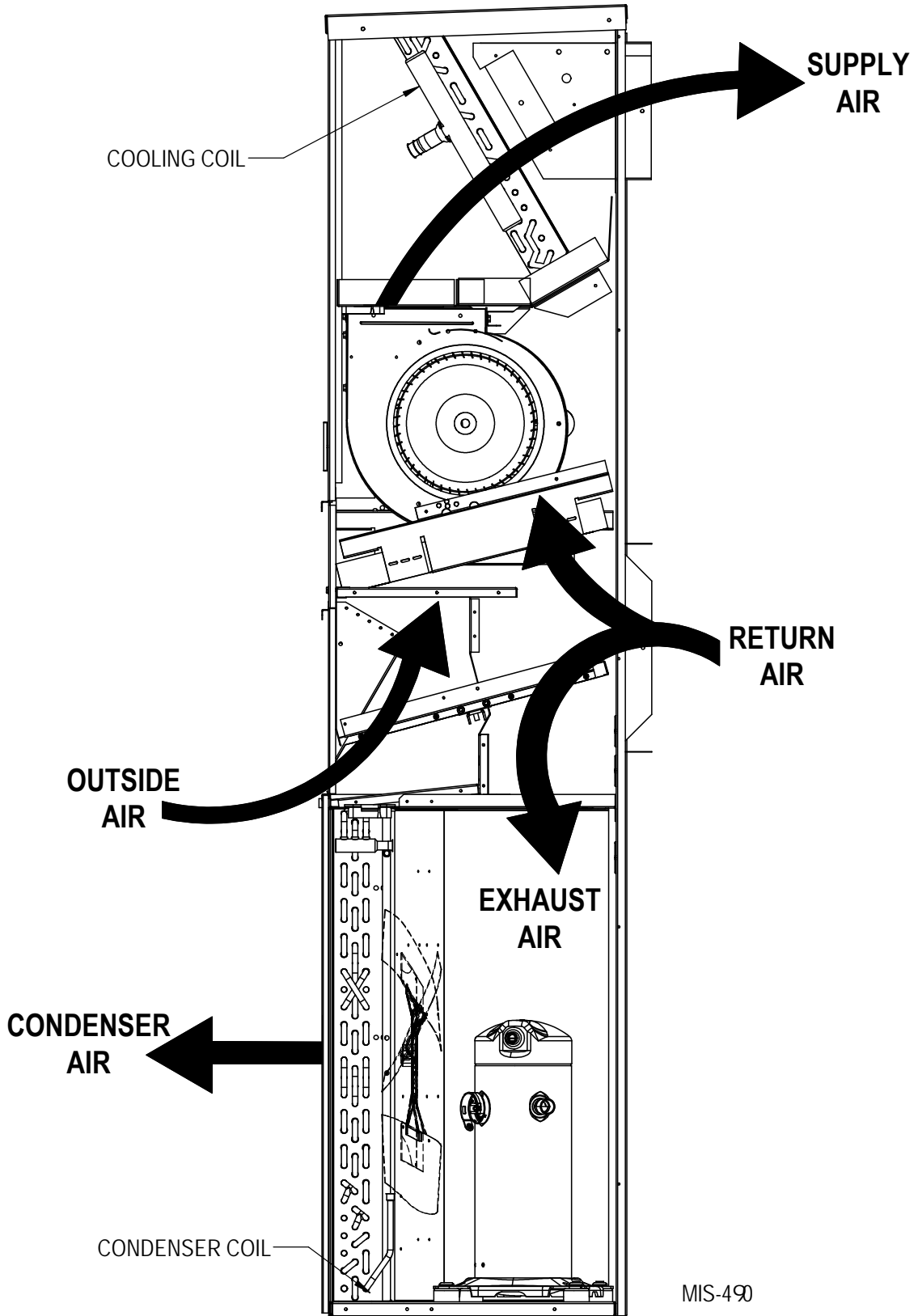

Energy Recovery Ventilator Maintenance

General Information

The ability to clean exposed surfaces within air moving systems is an important design consideration for the maintenance of system performance and air quality. The need for periodic cleaning will be a function of operating schedule, climate and contaminants in the indoor air being exhausted and in the outdoor air being supplied to the building. All components exposed to the airstream, including energy recovery wheels, may require cleaning in most applications.

Rotary counterflow heat exchanges (heat wheels) with laminar airflow are “self-cleaning” with respect to dry particles. Smaller particles pass through; larger particles land on the surface and are blown clear as the flow direction is reversed. For this reason, the primary need for cleaning is to remove films of oil-based aerosols that have condensed on energy transfer surfaces. Buildup of material over time may eventually reduce airflow. Most importantly, in the case of desiccant-coated (enthalpy) wheels, such films can close off micron-sized pores at the surface of the desiccant material, reducing the efficiency with which the desiccant can absorb and desorb moisture.

Frequency

In a reasonably clean indoor environment such as a school, office building or home, experience shows that reductions of airflow or loss of sensible (temperature) effectiveness may not occur for 10 or more years. However, experience also shows that measurable changes in latent energy (water vapor) transfer can occur in shorter periods of time in commercial, institutional and residential applications experiencing moderate occupant smoking or with cooking facilities. In applications experiencing unusually high levels of occupant smoking, such as smoking lounges, nightclubs, bars and restaurants, washing of energy transfer surfaces, as frequently as every 6 months, may be necessary to maintain latent transfer efficiency. Similar washing cycles may also be appropriate for industrial applications involving the ventilation of high levels of smoke or oil-based aerosols such as those found in welding or machining operations, for example. In these applications, latent efficiency losses of as much as 40% or more may develop over a period of 1 to 3 years.

Cleanability and Performance

In order to maintain energy recovery ventilation systems, energy transfer surfaces must be accessible for washing to remove oils, grease, tars and dirt that can impede performance or generate odors. Washing of the desiccant surfaces is required to remove contaminate buildups that can reduce absorption of water molecules. The continued ability of an enthalpy

wheel to transfer latent energy depends upon the permanence of the bond between the desiccant and the energy transfer surfaces.

Bard wheels feature silica gel desiccant permanently bonded to the heat exchange surface without adhesives; the desiccant will not be lost in the washing process. Proper cleaning of the Bard energy recovery wheel will restore latent effectiveness to near original performance.

Maintenance Procedures

NOTE: *Local conditions can vary and affect the required time between routine maintenance procedures; therefore, all sites (or specific units at a site) may not have the same schedule to maintain acceptable performance. The following timetables are recommended and can be altered based on local experience.*

Quarterly Maintenance

1. Inspect mist eliminator/prefilter and clean if necessary. This filter is located in the fresh air intake hood on the front of the unit. This is an aluminum mesh filter and can be cleaned with water and any detergent not harmful to aluminum.
2. Inspect wall-mount unit filter and clean or replace as necessary. This filter is located either in the unit, in a return air filter grille assembly or both. If in the unit it can be accessed by removing the lower service door on the front of the unit. If in a return air filter grille, by hinging the grille open to gain access.
3. Inspect energy recovery ventilator for proper wheel rotation and dirt buildup. This can be done in conjunction with Item 2 above. Energize the energy recovery ventilator after inspecting the filter and observe for proper rotation and/or dirt buildup.
4. Recommended energy recovery wheel cleaning procedures follow: Disconnect all power to unit. Remove the lower service door of the wall-mount unit to gain access to the energy recovery ventilator.
5. Remove the front access panel on the ventilator. Unplug amp connectors to cassette motors. Slide energy recovery cassette out of ventilator.
6. Use a shop vacuum with brush attachment to clean both sides of the energy recovery wheels.
7. Reverse shop vacuum to use as a blower and blow out any residual dry debris from the wheel.

NOTE: *Discoloration and staining of the wheel does not affect its performance. Only excessive buildup of foreign material needs to be removed.*

8. If any belt chirping or squealing noise is present, apply a small amount of LPS-1 or equivalent dry film lubricant to the belt.

Annual Maintenance

1. Inspect and conduct the same procedures as outlined under **Quarterly Maintenance**.
2. To maintain peak latent (moisture) removal capacity, it is recommended that the energy recovery wheels be sprayed with a diluted nonacid-based evaporator coil cleaner or alkaline detergent solution such as 409.

NOTE: Do not use acid-based cleaners, aromatic solvents, temperatures in excess of 170°F or steam. Damage to the wheel may result.

Do not disassemble and immerse the entire heat wheel in a soaking solution, as bearing and other damage may result.

3. Rinse wheel thoroughly after application of the cleaning solution and allow to drain before re-installing.
4. No re-lubrication is required to heat wheel bearings of the drive motor, or to the intake and exhaust blower motors.
5. If any belt chirping or squealing noise is present, apply a small amount of LPS-1 or equivalent dry film lubricant to the belt.

Figure 8
Belt Replacement Instructions
(Two Wheel Cassette Only)

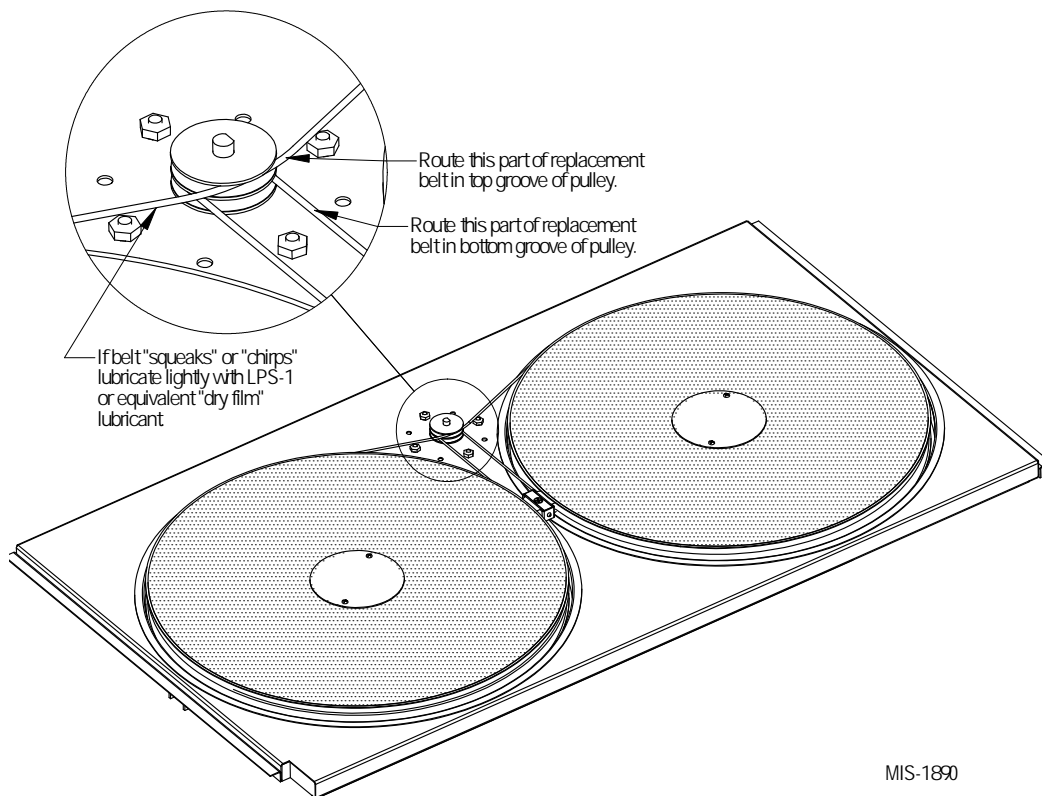
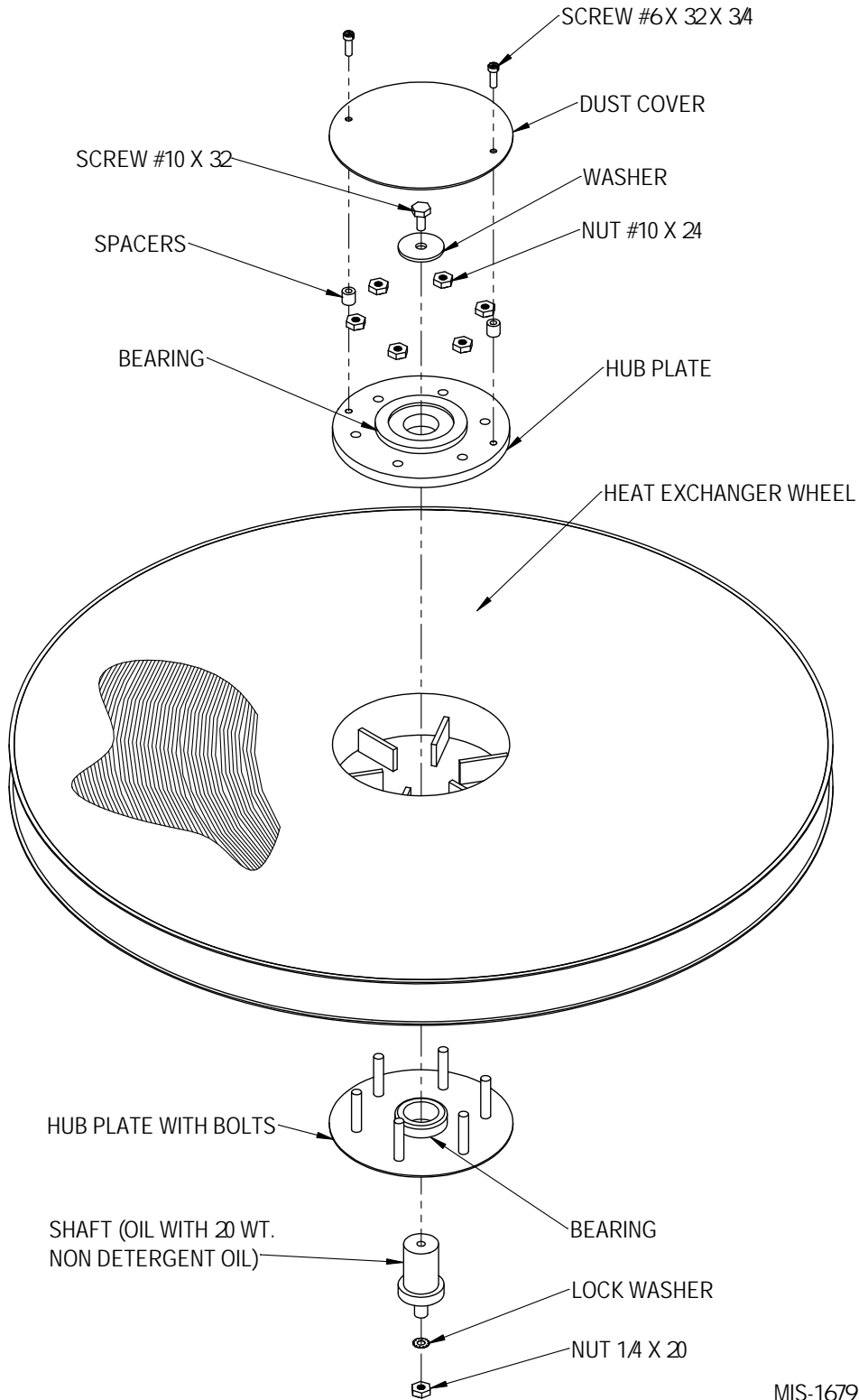

FIGURE 9
Hub Assembly with Ball Bearings



MIS-1679