INSTALLATION INSTRUCTIONS

Circuit Breaker Kits

Models:

WMCBC-08A	WMCBC-06C	WMCBC-09A
WMCBC-07A	WMCBC-04B	WMCBC-06B
WMCBC-05B	WMCBC-06F	WMCBC-08B



Climate Control Solutions

Bard Manufacturing Company, Inc.
Bryan, Ohio 43506
www.bardhvac.com

Manual: 2100-735
Supersedes: **NEW**
Date: 1-28-20

CONTENTS

General Information3

Description3

Nomenclature3

Installation4

Installation of Circuit Breaker4

Figures

Figure 1 Circuit Breaker Installation4

Figure 2 Serial Plate Label5

Table

Table 1 Applicable Kits for Listed Models.....3

GENERAL INFORMATION

Description

The WMCBC Kits are field-installable circuit breaker kits suitable for upgrading "00" kW Bard wall-mount heat pumps and air conditioners (-A, -B, -C, -E and -F electrical versions) to the "0Z" kW option. See Table 1 for applicable kits for listed models.

TABLE 1
Applicable Kits for Listed Models

	W42AC-A	W42HC-A	W42A/HC-B	W42A/HC-C	W42A/HC-E	W42A/HC-F	W42A/HCDA	W42A/HCDB	W42A/HCDC	W48A/HC-A	W48A/HC-B	W48A/HC-C	W48A/HC-E	W48A/HC-F	W48A/HCDA	W48A/HCDB	W48A/HCDC	W60A/HC-A	W60A/HC-B	W60A/HC-C	W60A/HC-E	W60A/HC-F	W60A/HCDA	W60A/HCDB	W60A/HCDC	W72AC-A	W72AC-B	W72AC-C	W72AC-F	W72ACDA	W72ACDB	W72ACDC	W5SAC-A	W5SAC-B	W5SAC-C			
WMCBC-08A	X						X			X					X																							
WMCBC-07A		X																																				
WMCBC-05B			X					X			X					X																						
WMCBC-06C				X					X			X					X			X					X			X				X					X	
WMCBC-04B					X								X																									
WMCBC-06F						X								X								X							X									
WMCBC-09A																		X					X			X				X			X					
WMCBC-06B																			X		X			X											X			
WMCBC-08B																											X				X							

Nomenclature

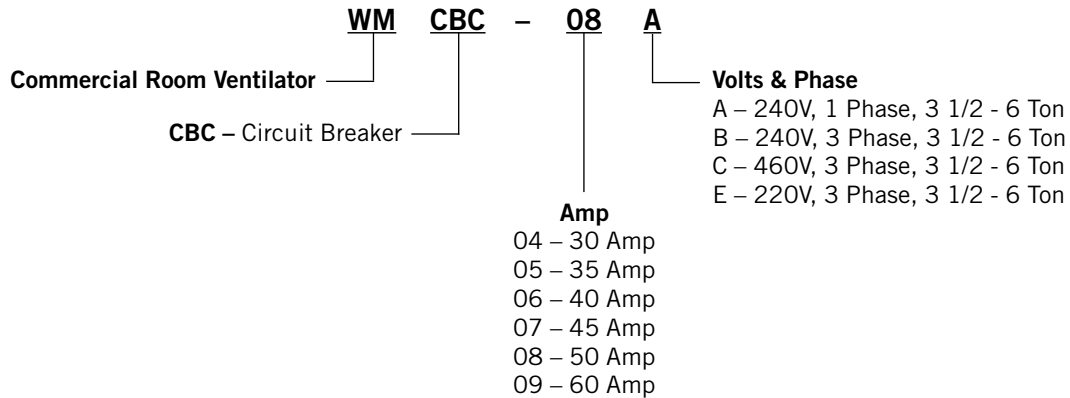

INSTALLATION

Installation of Circuit Breaker

1. Disconnect all power to unit. Remove control panel inner and outer covers.
2. Before installation, check unit serial plate to make sure the circuit breaker kit that is intended to be installed is listed as a kit suitable for use with the unit.
3. Mount circuit breaker assembly in position as shown in Figure 1 with screws provided.
4. Connect red compressor supply lead to L1 of terminal block. Connect black compressor supply lead to L2 of terminal block. If 3-phase unit, connect yellow supply lead to L3 of terminal block. See Figure 1 and wiring diagram (included with kit).
5. Connect field wiring to circuit breakers.
6. Attach adhesive wiring diagram directly above unit wiring diagram on inner control panel cover.
7. Recheck wiring. Break out appropriate circuit breaker tabs on inner control panel cover to allow trip lever to protrude.
8. Resupply power to the unit and check for proper operation.
9. Remark serial plate with self adhesive label attached to the front of this manual. See Figure 2 on page 5.

FIGURE 1
Circuit Breaker Installation

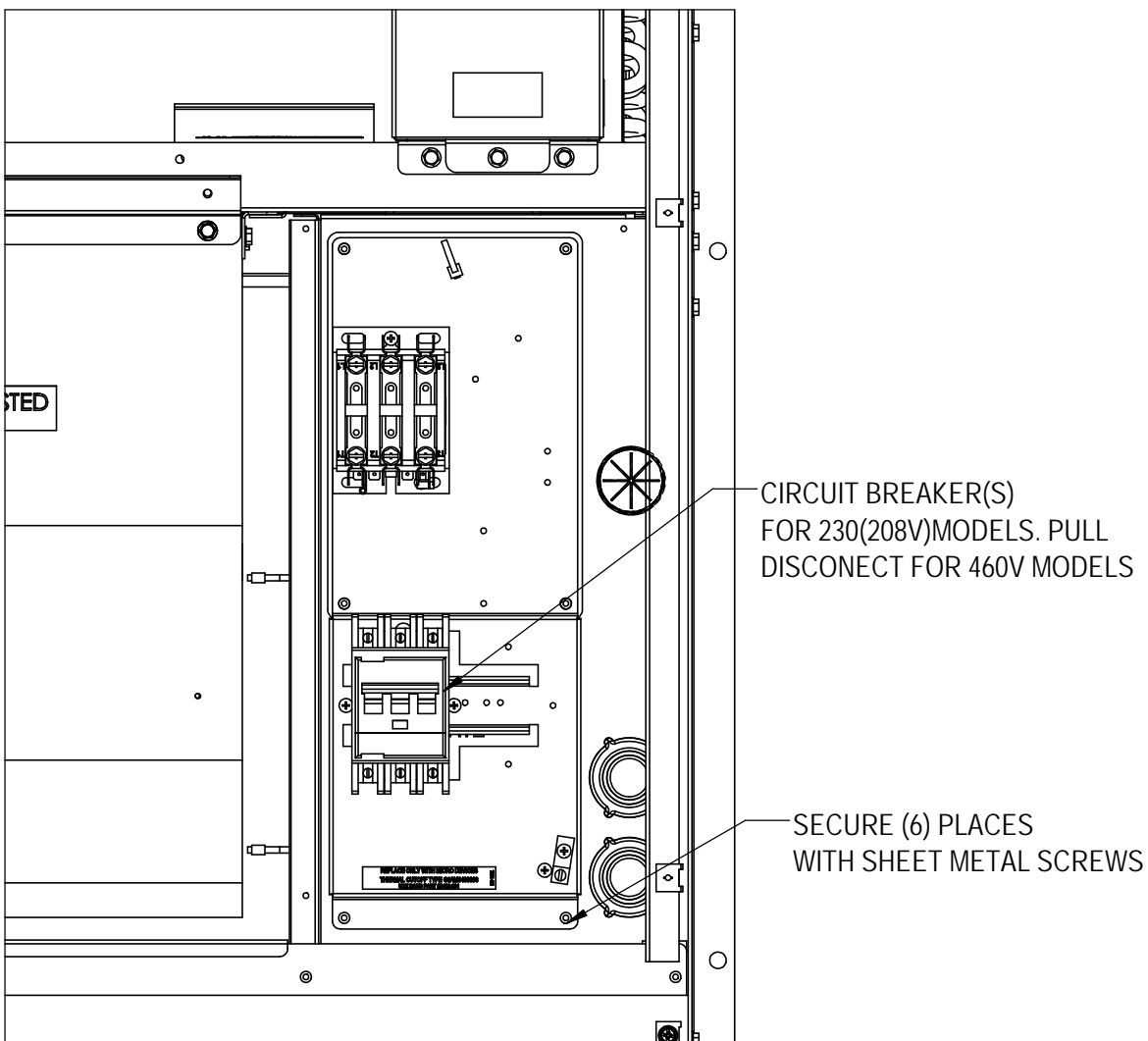

MIS-4141

FIGURE 2
Serial Plate Label

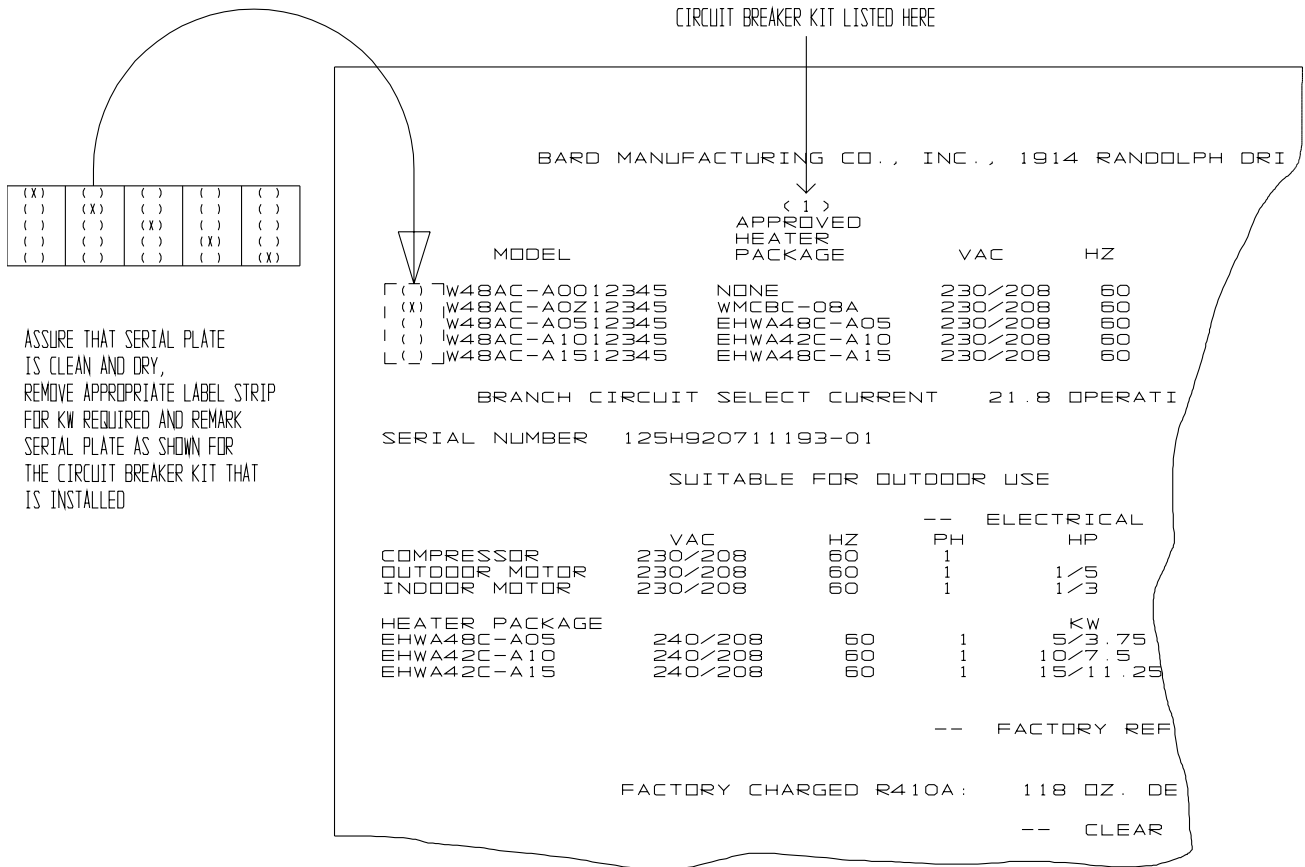

MIS-4142