

---

# INSTALLATION INSTRUCTIONS

---

## Commercial Room Ventilator with Exhaust

Model: CRVS-3A

For Use with Bard Heat Pump Models  
T24H, T30H and T30S



*Climate Control Solutions*

Bard Manufacturing Company, Inc.  
Bryan, Ohio 43506  
[www.bardhvac.com](http://www.bardhvac.com)

Manual: 2100-759A  
Supersedes: 2100-759  
Date: 8-10-22

# CONTENTS

---

## General

General Information.....	3
Unpacking.....	3
Description.....	3
Models.....	3
CRV Features.....	3
Sequence of Operation.....	3

## Installation

Basic Installation.....	4
CO <sub>2</sub> Control.....	7
Blade Adjustment for Desired Ventilation Air.....	10
"V" Option CRV Sequence of Operation.....	12

## Figures

Figure 1	Removal of Exterior Panels.....	4
Figure 2	Removal of Exhaust Cover Plate.....	5
Figure 3	Install Ventilator.....	6
Figure 4	8403-096 CO <sub>2</sub> Sensor Set Up.....	8
Figure 5	CRV Control Board Wiring.....	9
Figure 6	CRV Control Board.....	11
Figure 7	CRV Control Board.....	12
Figure 8	Call for Ventilation with or without Compressor Operation.....	15
Figure 9	Call for Compressor or Fan Only with Ventilation Off.....	16

## Graphs

Graph 1	T30* High Speed Total and Vent Airflow.....	14
Graph 2	T24H High & T30* Low Speed Total and Vent Airflow.....	14

## General Information

The ventilator should only be installed by a trained heating and air conditioning technician. These instructions serve as a guide to the technician installing the ventilator package. They are not intended as a step-by-step procedure with which the mechanically inclined owner can install the package.

The ventilator housing is shipped in one carton which contains the electrical harness, miscellaneous hardware and installation instructions.

## Unpacking

Upon receipt of the equipment, be sure to compare the model number found on the shipping label with the accessory identification information on the ordering and shipping document to verify that the correct accessory has been shipped.

Inspect the carton housing of each ventilator as it is received. Before signing the freight bill, verify that all items have been received and that there is no visible damage. Note any shortages or damage on all copies of the freight bill. The receiving party must contact the last carrier immediately, preferably in writing, requesting inspection by the carrier's agent. Concealed damage not discovered until after loading must be reported to the carrier within 15 days of its receipt.

## Description

The CRVS-3A ventilator is designed to be used with Bard heat pump models T24H, T30H and T30S. It is an electromechanical vent system designed to provide fresh air to meet indoor air quality standards.

## Models

When installed in the above listed models, the CRV provides built-in exhaust provisions. When the damper blade opens to bring fresh air in, the damper also opens an exhaust relief. The exhaust air will flow into the condenser section of the unit. The condenser fan will help draw exhaust air out.

## CRV Features

- One piece construction – easy to install.
- Exhaust air damper – built in with positive closed position. Provides exhaust air capability to prevent pressurization of tight buildings.
- Actuator motor – 24 volt, power open, spring return with built in torque limiting switch.

## WARNING

**Electrical shock hazard.**

**Disconnect remote electrical power supply or supplies before servicing.**

**Failure to do so could result in electric shock or death.**

## WARNING

**Exposed moving parts.**

**Disconnect all electrical power before servicing.**

**Failure to do so can result in severe injury or amputation.**

## CAUTION

**Sharp metallic edges.**

**Take care and wear appropriate protective devices to avoid accidental contact with sharp edges.**

**Failure to do so can result in personal injury.**

## Sequence of Operation

On a call for blower operation, CRV will open to pre-purge position as set by "PP" potentiometer for the amount of time set by the PP jumper. The CRV will then move to the position set by the "OCC" potentiometer. If PP jumper is in 0 position, the CRV will immediately open to the position set by the "OCC" potentiometer.

**NOTE:** These sequence descriptions do not apply if CO<sub>2</sub> controller is used. The CRV will control according to observed CO<sub>2</sub> levels in the conditioned space. Refer to information on page 8.

A call for 1st stage cooling or heating cycles the compressor, and the dampers reposition to the Y1 potentiometer setpoint. A call for 2nd stage cooling or heating energizes compressor solenoid and repositions the damper blade to the Y2 potentiometer position. On loss of blower operation, CRV closes fully.

# INSTALLATION

## Basic Installation

1. Unpack the ventilator assembly which includes the integral ventilator with attached electrical harness and miscellaneous hardware.

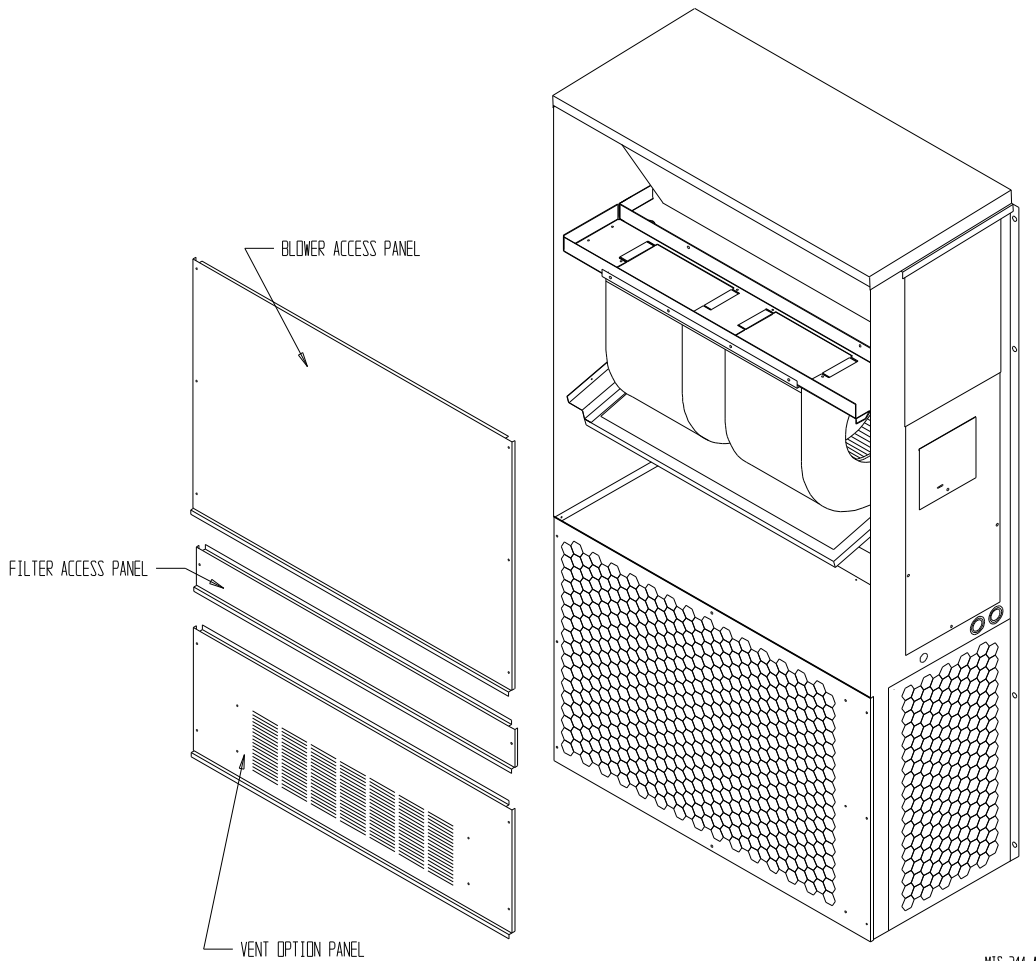
### **WARNING**

*Open and lock disconnect switch before installing this accessory to prevent injury or death due to electrical shock or contact with moving parts. Turn thermostat to off.*

Model	For Use with Following Units	
CRVS-3A	T24H T24H1D T30H T30H1D	T30S T30S1D

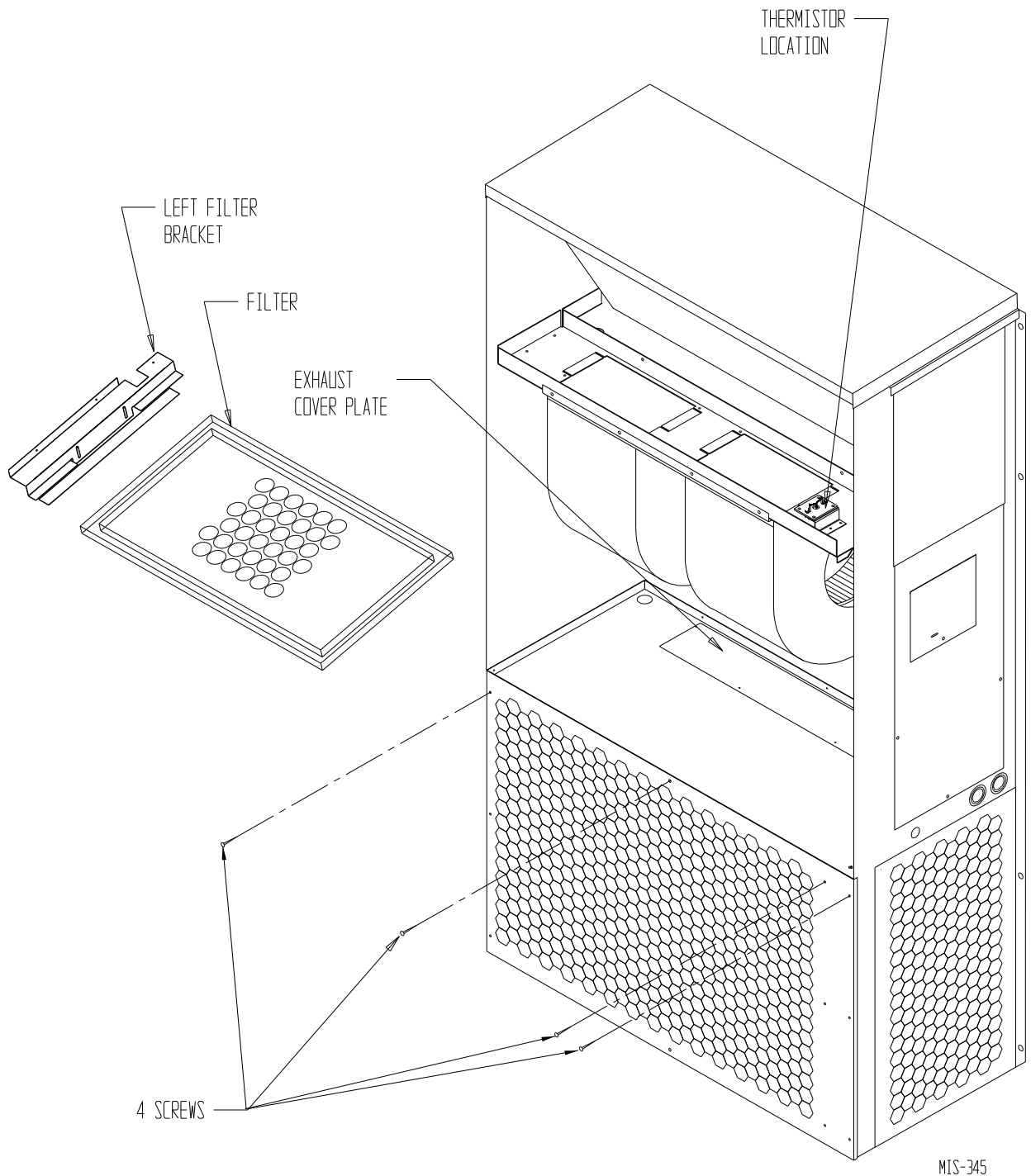
2. Remove and save the existing exterior blower access and service access panels on the Bard wall mount unit (see Figure 1).

**FIGURE 1**  
Removal of Exterior Panels



3. Remove and save existing unit return air filter and left side filter support bracket by removing two (2) screws from front side of unit (see Figure 2). Remove and save top four (4) screws from grille.
4. Remove and discard the exhaust cover plate.

**FIGURE 2**  
**Removal of Exhaust Cover Plate**

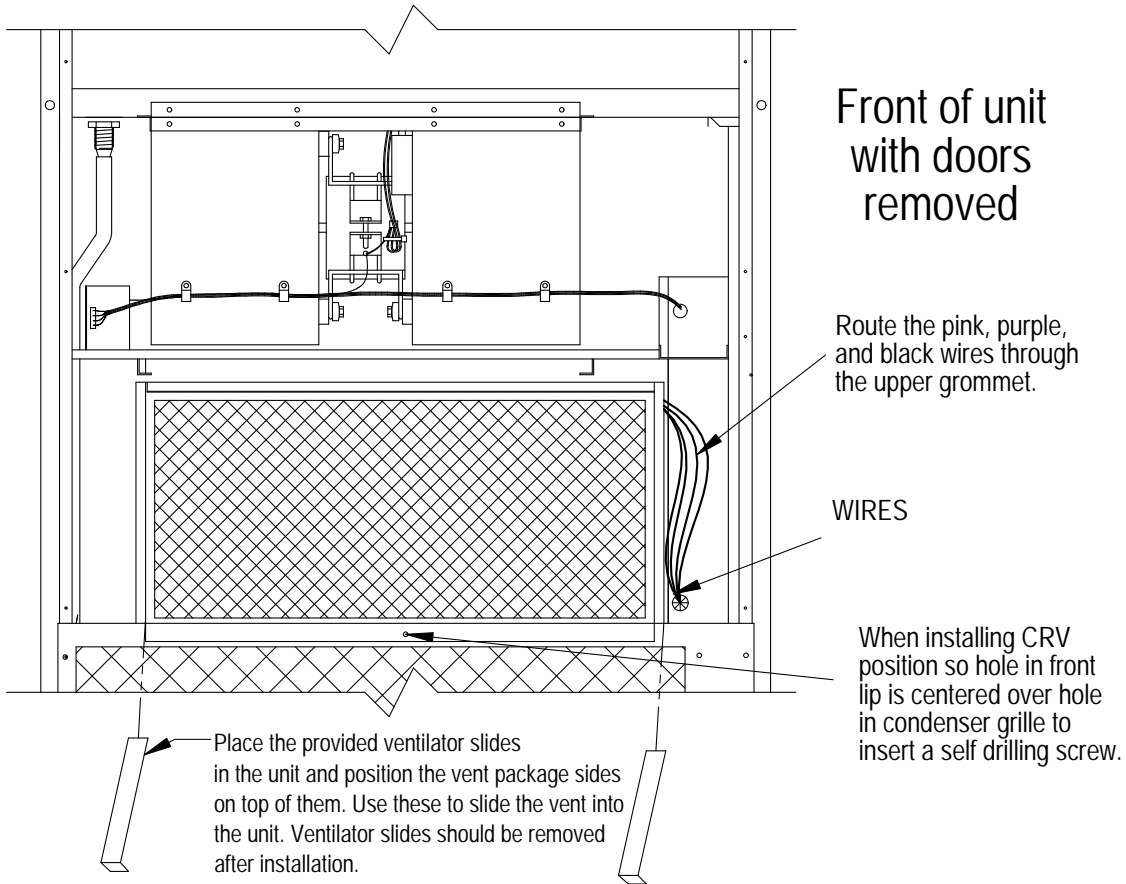


5. Install ventilator into unit (see Figure 3).

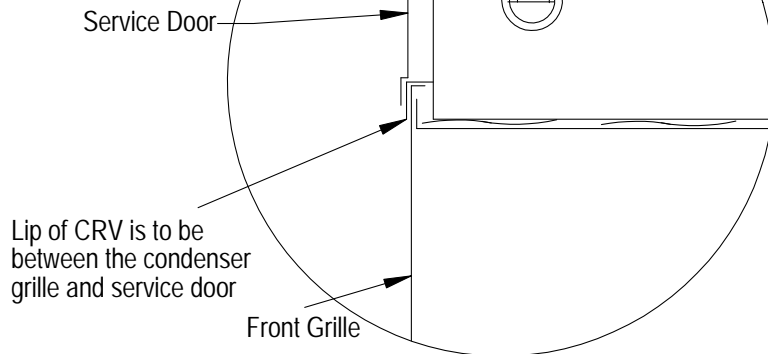
**IMPORTANT:** Position front lip of ventilator on top of front grille and condenser partition (see Figure 3 inset). This is important to ensure proper drainage of any water entering damper assembly.

5. Open control panel to gain access to unit low voltage terminal block.
6. Route electrical harness leads through the 7/8" bushings in control panel into low voltage box (as shown in Figure 3).

**FIGURE 3**  
**Install Ventilator**



**Right side of CRV in unit**



**Note:** Plug the (4) Ø.125 holes in the service door with canoe clips.

MIS-2030 A

7. Make the following connections from the CRV wire harness to the screw terminals on the low voltage terminal strip:
  - Brown/White wire to the "O1" terminal
  - Black/White wire to the "C" terminal
  - Red/White wire to the "R" terminal
  - Orange wire to the "G" terminal
  - Yellow/White wire to the "Y" terminal
  - Purple wire to the "Y1" terminal
8. Close control panel cover
9. Replace left filter support, filter and four (4) screws in condenser grille.
10. Re-install the blower access panel at top of unit and secure with sheet metal screws.
11. Ventilator Checkout
  - A. Resupply power to unit.
  - B. Move "PP" jumper on CRV control board (Bard P/N 8201-167) to the 30-minute position.
  - C. Ventilator should open to the position set by the "PP" potentiometer. Cycle the potentiometer from full open to full closed. Observe damper blade operation throughout travel to assure free, unobstructed movement. Return "PP" potentiometer to desired position for pre-purge airflow (refer to graphs 1 and 2 on pages xx-xx). Move the "PP" jumper to the 0 position. Ventilator should open to the position set by the "OCC" potentiometer.

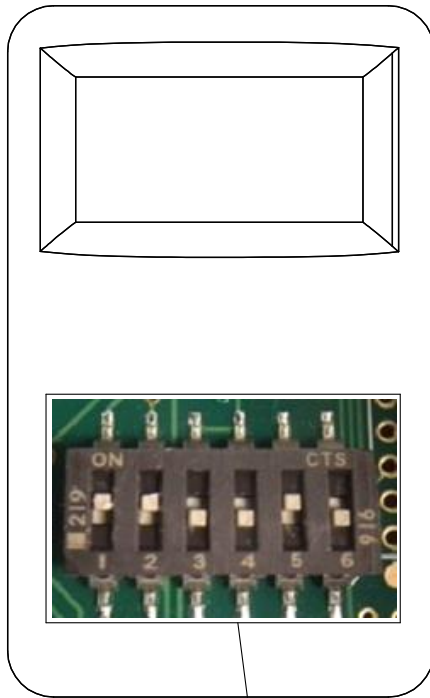
Energize Y; ventilator should open to the position set by the "Y1" potentiometer.  
Energize Y1; ventilator should open to the position set by the "Y2" potentiometer.
  - D. De-energize evaporator blower. Damper blade should close.
  - E. If pre-purge function is desired, move "PP" jumper to the 30-, 60-, or 90-minute position depending on desired pre-purge time.
  - F. This completes ventilator checkout.
12. Replace mist eliminator. Be sure it is installed with the drain holes to the bottom.
13. Remove blank off plate or barometric fresh air damper installed on service access door. Plug four (4) mounting holes with the plastic plugs provided with the ventilator.
14. Replace service access panel.
15. Ventilator is now ready for operation.
16. If retrofitting an existing unit, thermostat connection may change. See latest revision of manual 2100-507, 2100-516 or 2100-554 for proper thermostat connections to low voltage terminal strip with this CRVS.

## CO<sub>2</sub> Control

For CO<sub>2</sub>-based control, add a CO<sub>2</sub> sensor/controller (Bard P/N 8403-096) to the wall and run additional optional wires as shown in Figure 5 on page 9.

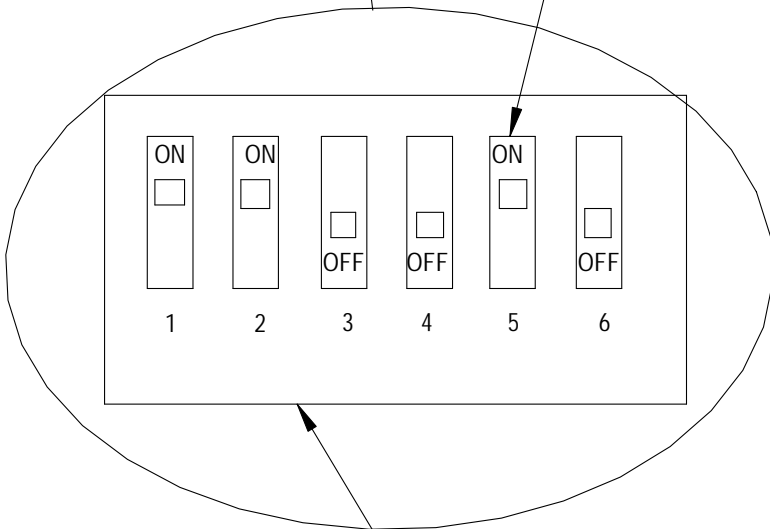
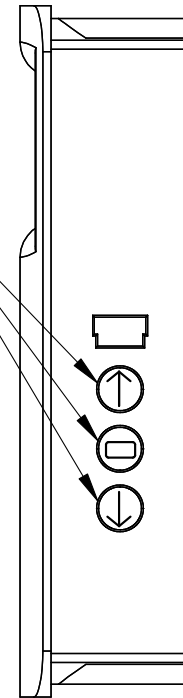
The CO<sub>2</sub> controller also must be re-configured from the standard default settings as it comes out of the box. See Figure 4 on page 8 for complete details.

**FIGURE 4**  
**8403-096 CO<sub>2</sub> Sensor Set Up**



PRESS UP AND DOWN  
 ARROWS TO ENTER  
 CONFIGURATION MODE.  
 USE ARROWS TO SELECT  
 SETTING. PUSH MIDDLE  
 BUTTON TO CHANGE.  
 CONTROLLER WILL  
 SHOW SET.

NOTE: MENU  
 DIP SWITCH MUST  
 BE IN "ON" POSITION #5  
 TO CHANGE ANY  
 SETTINGS WITH  
 THE SIDE BUTTONS.  
 TO LOCK THE CO2  
 CONTROLLER MOVE  
 DIP SWITCH TO "OFF" AFTER  
 IT HAS BEEN CONFIGURED.



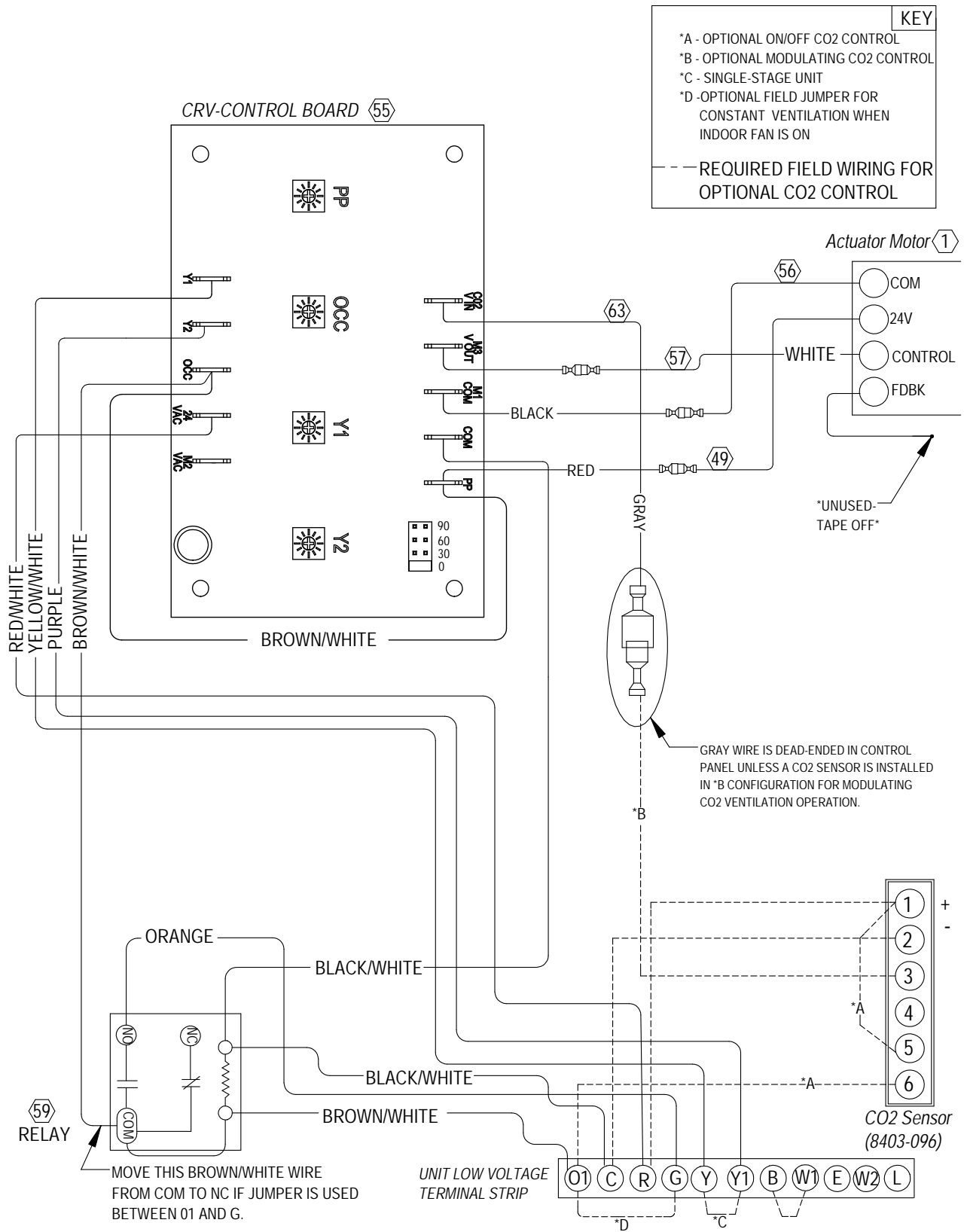
DIP SWITCHES MUST BE  
 POSITIONED AS SHOWN  
 FOR PROPER OPERATION

Settings	Recommended	Default
RON (RELAY ON SET POINT)	725	
ROF (RELAY OFF SET POINT)	700	
DSP (DISPLAY CONFIGURATION)	C	CT
UNI (UNITS SELECTION)	US	US
COL (CO2 LOW OUTPUT RANGE)	700	0
COH (CO2 HIGH OUTPUT RANGE)	1500	2000
TOL (TEMP. LOW OUTPUT RANGE)	Not Used	
TOH (TEMP. HIGH OUTPUT RANGE)	Not Used	
BAR (BAROMETRIC PRESSURE)	See Instructions with Controller For High Altitude Installations	
CAL (CALIBRATION)	Used for Field Calibration	

MIS-4025 C



**FIGURE 5**  
**CRV Control Board Wiring**



4056-261 C

## Blade Adjustment for Desired Ventilator Air

The amount of ventilation air supplied by the commercial room ventilator is dependent on four (4) factors:

1. Return air duct static pressure drop.
2. Supply air duct static pressure drop.
3. Indoor blower motor speed.
4. Damper blade open position setting.

Refer to the graph below to determine the blade setting necessary to achieve the ventilation air required for each operating mode.

Factory default settings are:

	<u>TS</u>	<u>TH</u>
PP Potentiometer	Closed	Closed
OCC Potentiometer	C	C
Y1 Potentiometer	C	C
Y2 Potentiometer	C	C

Vent is factory set to supply between 100 and 150 CFM of fresh air in all modes of occupied operation.

For more accurate adjustment, use a flowhood over the intake opening to measure and adjust the airflow operation.

PP Potentiometer: Adjusts the airflow during pre-purge mode (if jumper is installed in positions 30-90).

OCC Potentiometer: Adjusts the airflow during blower-only operation, or during an occupied input from an applicable thermostat.

Y1 Potentiometer: Adjusts the airflow during 1st stage cooling or heating operation.

Y2 Potentiometer: Adjusts the airflow during 2nd stage cooling or heating operation.

Energize blower-only mode and adjust OCC potentiometer to desired airflow.

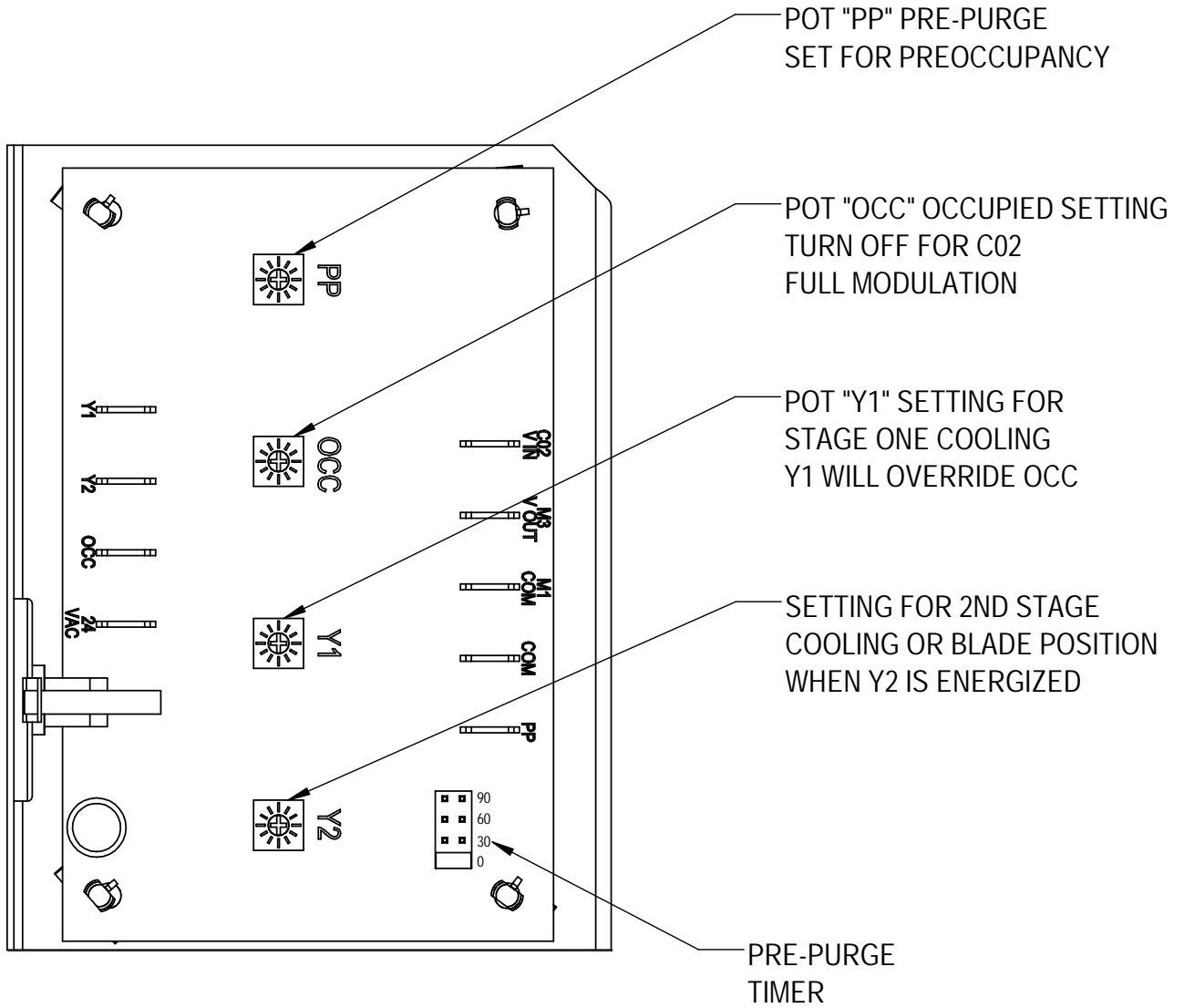
Energize 1st stage cooling mode and adjust Y1 potentiometer to desired airflow.

Energize 2nd stage cooling mode and adjust Y2 potentiometer to desired airflow.

If pre-purge mode is desired, de-energize cooling modes. Move PP jumper to the 30-, 60-, or 90-minute position and adjust PP potentiometer to desired airflow.

Minimum damper position when using CO<sub>2</sub> control damper should be fully closed at 700 ppm or lower, if not OCC potentiometer OCC can be adjusted counter-clockwise (CCW) to close it. If it is fully closed at 700 ppm or lower, no adjustments required.

FIGURE 6  
CRV Control Board



MIS-4047

## "V" Option CRV Sequence of Operation

The "V" Ventilation option includes a control board with blade positioning potentiometers along with an input for a 2-10V input signal (see Figure 7).

Adjustable potentiometers:

**"PP" Potentiometer setting:** This potentiometer can be used to adjust the blade setting for outdoor air intake during a pre-purge cycle. The pre-purge cycle time is based on the setting of the pre-purge timer.

**"OCC" Potentiometer setting:** This potentiometer can be used to adjust the blade setting for outdoor air intake when the "O1" terminal is energized on the low voltage terminal strip indicating occupancy.

**"Y1" Potentiometer setting:** This potentiometer can be used to adjust the blade setting for outdoor air intake when the "Y" terminal is energized on the low voltage terminal strip indicating 1st stage cooling or Balanced Climate operation. When energized, it overrides the "OCC" potentiometer setting.

**"Y2" Potentiometer setting:** This potentiometer can be used to adjust the blade setting for outdoor air intake when the "Y1" terminal is energized on the low voltage terminal strip indicating 2nd stage cooling operation. When energized, it overrides the "OCC" and "Y1" potentiometer settings.

### Pre-Purge Feature

Pre-purge is used to ventilate a specified CFM amount before occupants enter the room or structure. The control board has a built-in pre-purge timer that can be set to 30-, 60- and 90-minute intervals by moving the jumper noted in Figure 6 on page 11. This timer will start when the jumper is installed and the "O1" terminal is energized on the low voltage terminal strip. Blade adjustment can be made on the PP potentiometer. Once the timer has timed out, the board will default to the occupied setting and this blade position can be adjusted on the OCC potentiometer. If the timer is set to 0 (off—shipped position), the occupied setting is instantaneous and the pre-purge setting (PP) is no longer in the sequence.

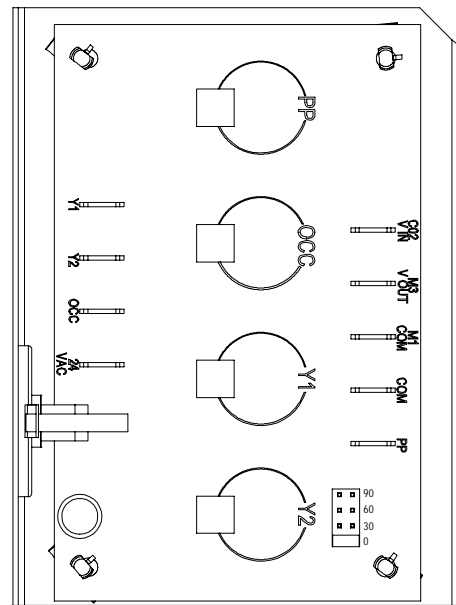
### Occupied Setting

Occupied is used to ventilate a specified CFM amount when occupants enter the room or structure. The control board will energize the occupied setting after the pre-purge cycle, or if pre-purge is disabled immediately when the "O1" terminal is energized on the low voltage strip. Blade adjustment can be made on the OCC potentiometer.

### Y1 Setting

Y1 is used to ventilate a specified CFM amount when Y cooling is energized. The control board will energize the Y1 setting when Y is energized on the low voltage strip. Blade adjustment can be made on the Y1

**FIGURE 7**  
**CRV Control Board**



potentiometer. This potentiometer setting overrides the OCC occupied setting.

### Y2 Setting

Y2 is used to ventilate a specified CFM amount when Y1 cooling is energized. The control board will energize the Y2 setting when Y1 is energized on the low voltage strip. Blade adjustment can be made on the Y2 potentiometer. This potentiometer setting overrides the OCC occupied and the Y1 setting.

### 2-10V Operation

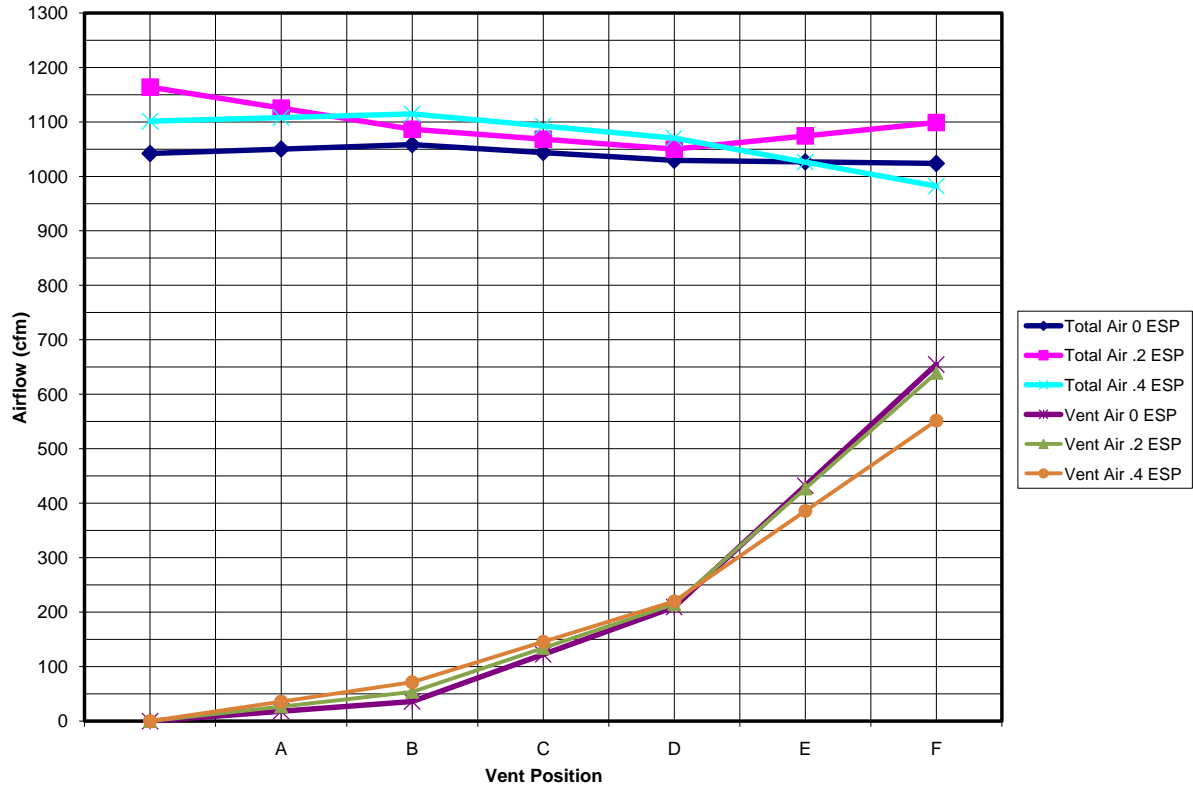
A CO<sub>2</sub> sensor or other device sending a 2-10V signal can be used to control the damper motor. Two control methods are available to control the damper motor:

- Method 1: The control board will accept a 2-10VDC signal with a resistive load greater than 5000 ohms. Bard CO<sub>2</sub> sensor 8403-096 can be used when the 2-10V output is connected to the blade connector on the unlanded gray wire from the CRV, located near the unit low voltage terminal strip. The occupied OCC potentiometer setting must be set to the off position for total modulation. The OCC potentiometer can be used to maintain a minimum blade position when "O1" is energized.
- Method 2: The damper motor will accept a 2-10VDC signal with a resistive load less than 5000 ohms. This method involves bypassing the control board and powering the motor directly from the device providing the 2-10VDC modulating signal. The gray wire connected to CO<sub>2</sub> VIN on the control board must be spliced with the white wire

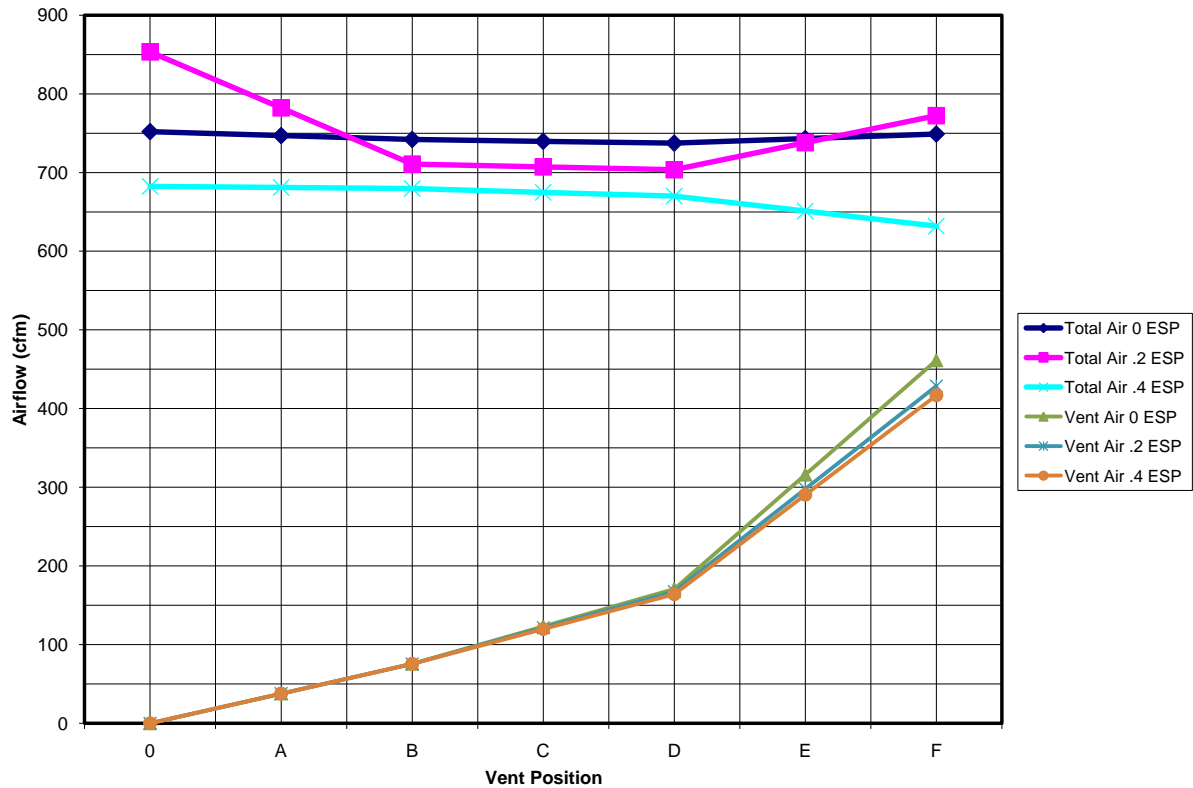
ran to the damper motor (OUT on control board).  
The other end of the gray wire should be connected  
to the CO<sub>2</sub> sensor as stated in Method 1.

During 2-10VDC operation with "01" energized and  
pre-purge timed operation active, DC voltage signaling  
occupancy from a source such as a CO<sub>2</sub> sensor will  
increase ventilation amounts as needed.

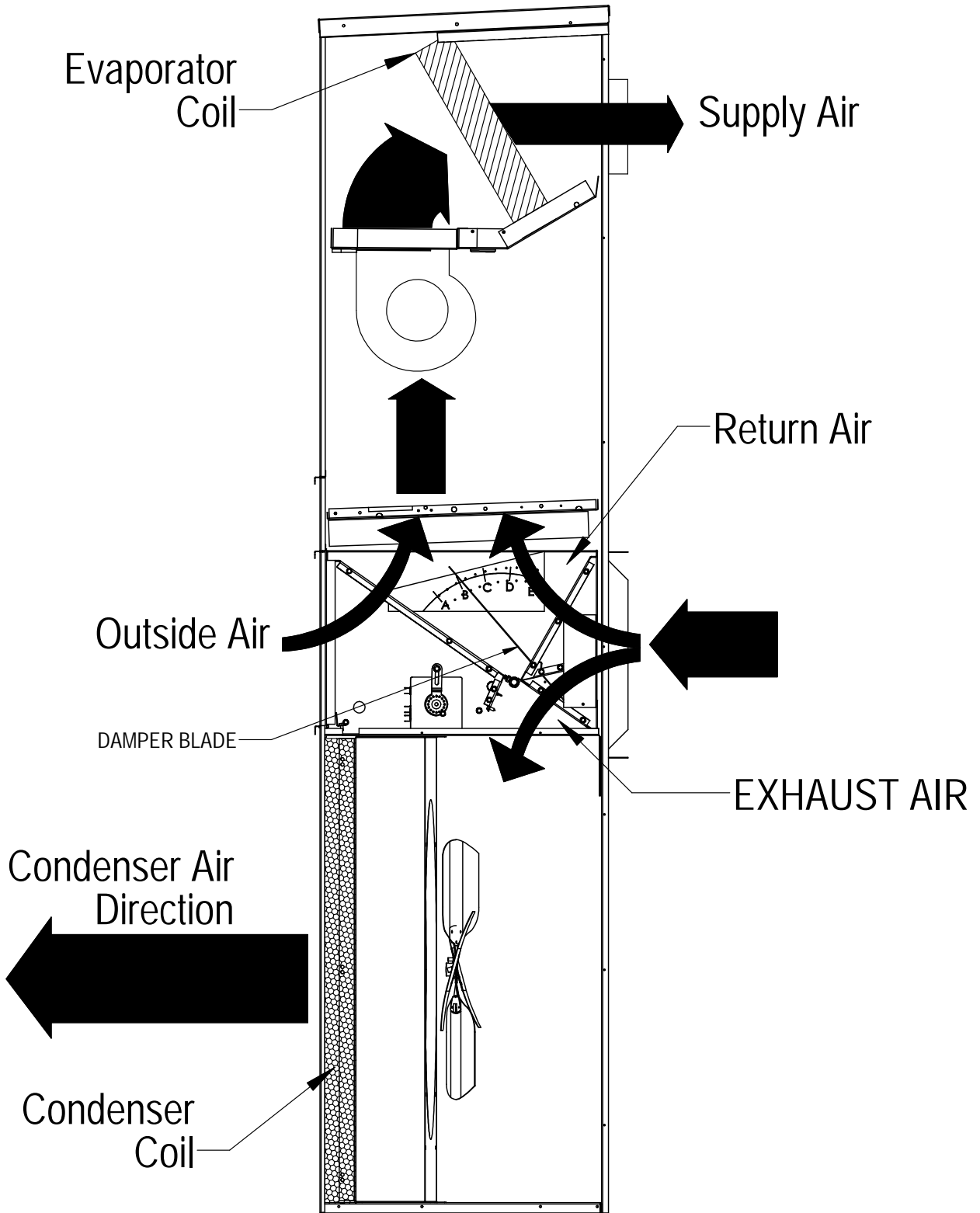
**GRAPH 1**  
**T30\* High Speed Total and Ventilation Airflow**



**GRAPH 2**  
**T24H High Speed Total and Ventilation Airflow/T30\* Low Speed Total and Ventilation Airflow**

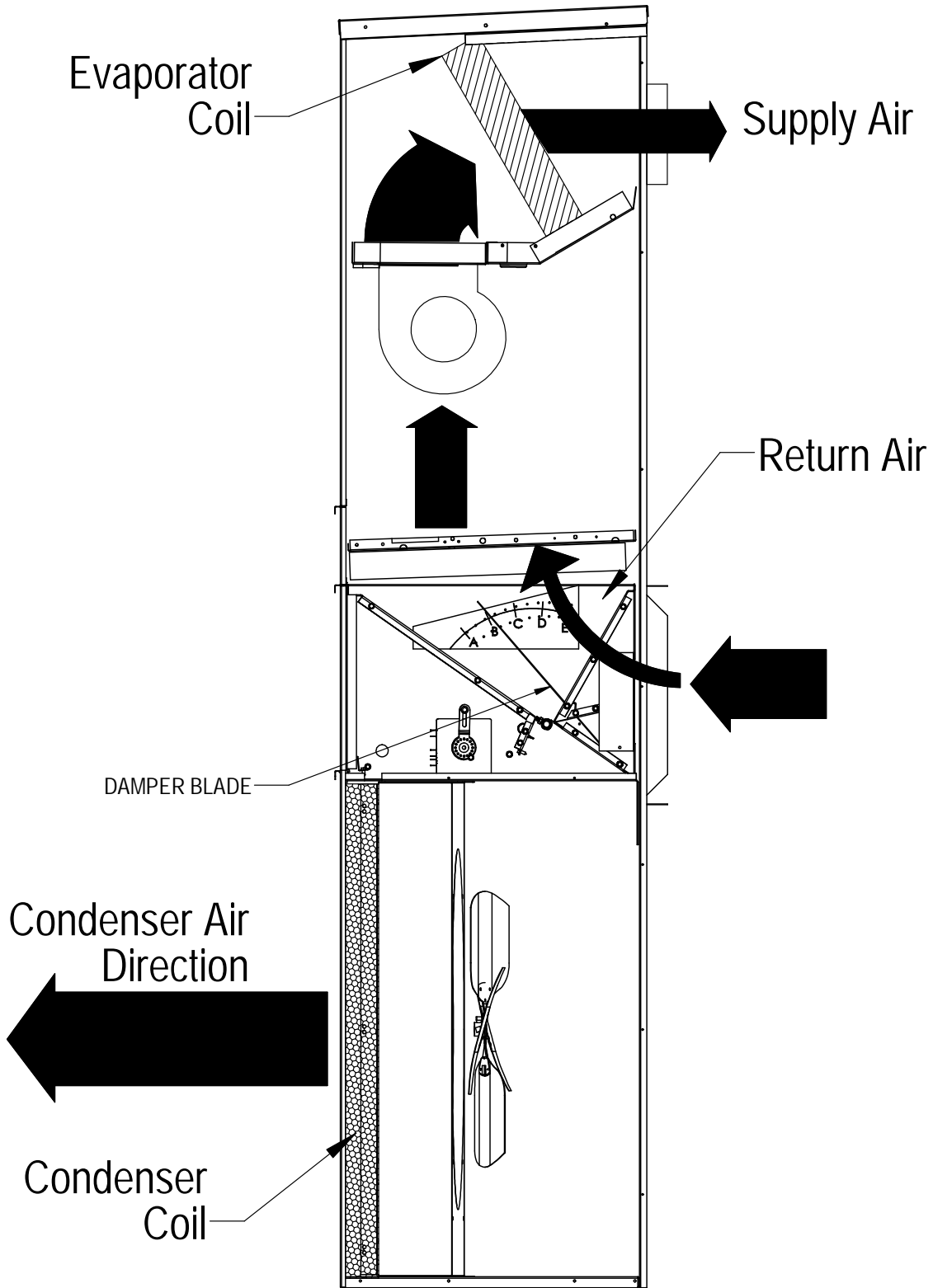


**FIGURE 8**  
**Call for Ventilation**  
with or without Compressor Operation



MIS-347A

**FIGURE 9**  
Call for Compressor or Fan Only  
with Ventilation Off



MIS-348A