INSTALLATION INSTRUCTIONS

Commercial Room Ventilator with Exhaust

Model:
CRVS-5A

For Use with Bard Heat Pump Models
T36-60H and T36-60S



Bard Manufacturing Company, Inc.
Bryan, Ohio 43506
www.bardhvac.com

Manual : 2100-760
Supersedes: **NEW**
Date: 12-8-21

CONTENTS

General	3
General Information.....	3
Unpacking.....	3
Description.....	3
Models.....	3
CRV Features.....	3
Sequence of Operation.....	3
Installation	4
Basic Installation	4
Blade Adjustment for Desired Ventilator Air	8
“V” Option CRV Sequence of Operation	10

FIGURES

Figure 1	Removal of Exterior Panels.....	4
Figure 2	Removal of Air Filter and Exhaust Cover Plate.....	5
Figure 3	Reroute Wires for Left Hand CRVS-5A Units Only.....	6
Figure 4	Install Ventilator	7
Figure 5	CRV Control Board	9
Figure 6	CRV Control Board	10
Figure 7	8403-096 CO2 Sensor Set Up.....	12
Figure 8	CRV Control Board Wiring	13
Figure 9	Call for Blower Operation	16
Figure 10	Call for Compressor or Fan Only with Ventilation Off	17

GRAPHS

Graph 1	Commercial Room Ventilator Performance Data: T36 with CRVS-5A ..	14
Graph 2	Commercial Room Ventilator Performance Data: T42 with CRVS-5A ..	14
Graph 3	Commercial Room Ventilator Performance Data: T48 with CRVS-5A ..	15
Graph 4	Commercial Room Ventilator Performance Data: T60 with CRVS-5A ..	15

General Information

The ventilator should only be installed by a trained heating and air conditioning technician. These instructions serve as a guide to the technician installing the ventilator package. They are not intended as a step-by-step procedure with which the mechanically inclined owner can install the package.

The ventilator housing is shipped in one carton which contains the electrical harness, miscellaneous hardware and installation instructions.

Unpacking

Upon receipt of the equipment, be sure to compare the model number found on the shipping label with the accessory identification information on the ordering and shipping document to verify that the correct accessory has been shipped.

Inspect the carton housing of each ventilator as it is received. Before signing the freight bill, verify that all items have been received and that there is no visible damage. Note any shortages or damage on all copies of the freight bill. The receiving party must contact the last carrier immediately, preferably in writing, requesting inspection by the carrier's agent. Concealed damage not discovered until after loading must be reported to the carrier within 15 days of its receipt.

Description

The CRVS-5A ventilator is designed to be used with Bard heat pump models T36-60H and T36-60S. It is an electromechanical vent system designed to provide fresh air to meet indoor air quality standards.

Models

When installed in the above listed models, the CRV provides built-in exhaust provisions. When the damper blade opens to bring fresh air in, the damper also opens an exhaust relief. The exhaust air will flow into the condenser section of the unit. The condenser fan will help draw exhaust air out.

CRV Features

- One piece construction—easy to install with no mechanical linkage adjustment required.
- Exhaust air damper—built in with positive closed position. Provides exhaust air capability to prevent pressurization of tight buildings.
- Actuator motor—24 volt, power open, spring return with built-in torque limiting switch.
- Provides up to 75% of outside air.

WARNING

Electrical shock hazard.

Disconnect remote electrical power supply or supplies before servicing.

Failure to do so could result in electric shock or death.

WARNING

Exposed moving parts.

Disconnect all electrical power before servicing.

Failure to do so can result in severe injury or amputation.

CAUTION

Sharp metallic edges.

Take care and wear appropriate protective devices to avoid accidental contact with sharp edges.

Failure to do so can result in personal injury.

Sequence of Operation

On a call for blower operation, CRV will open to pre-purge position as set by "PP" potentiometer for the amount of time set by the PP jumper. The CRV will then move to the position set by the "OCC" potentiometer. If PP jumper is in 0 position, the CRV will immediately open to the position set by the "OCC" potentiometer.

A call for 1st stage cooling or heating cycles the compressor, and the dampers reposition to the Y1 potentiometer setpoint. A call for 2nd stage cooling or heating energizes compressor solenoid and repositions the damper blade to the Y1 potentiometer position. On loss of blower operation, CRV closes fully.

INSTALLATION

Basic Installation

1. Unpack the ventilator assembly which includes the integral ventilator with attached electrical harness and miscellaneous hardware.

WARNING

Open and lock disconnect switch before installing this accessory to prevent injury or death due to electrical shock or contact with moving parts. Turn thermostat to off.

Model	For Use with Following Units	
CRVS-5A	T36H T42H T48H T60H	T36S T42S T48S T60S

2. Remove and save the existing exterior blower access and service access panels on the Bard wall mount unit (see Figure 1).

FIGURE 1
Removal of Exterior Panels

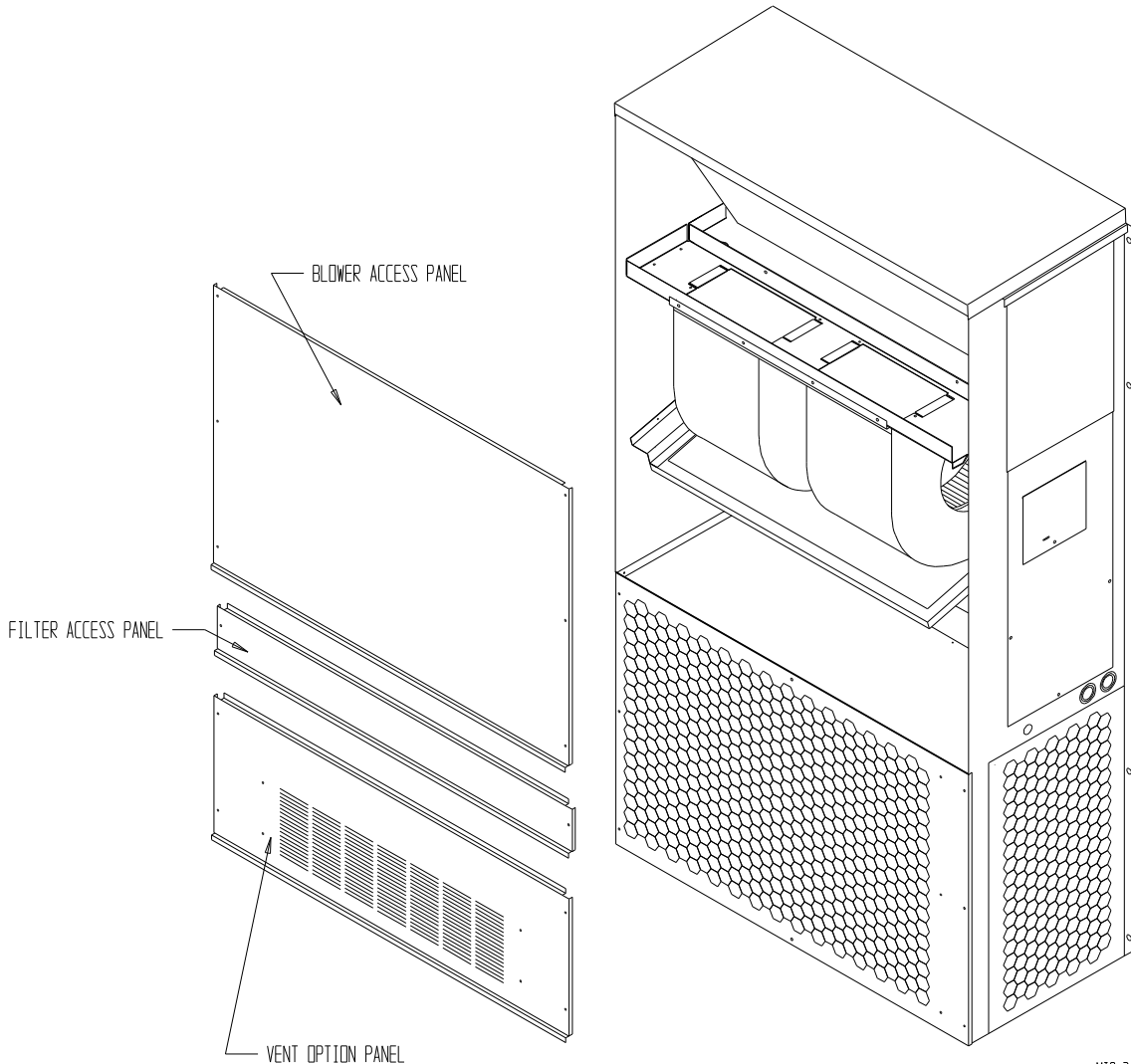

MIS-344 A

3. Remove and save existing unit air filter and screws from front center grille (see Figure 2).
4. Remove and discard the exhaust cover plate.

FIGURE 2
Removal of Air Filter and Exhaust Cover Plate

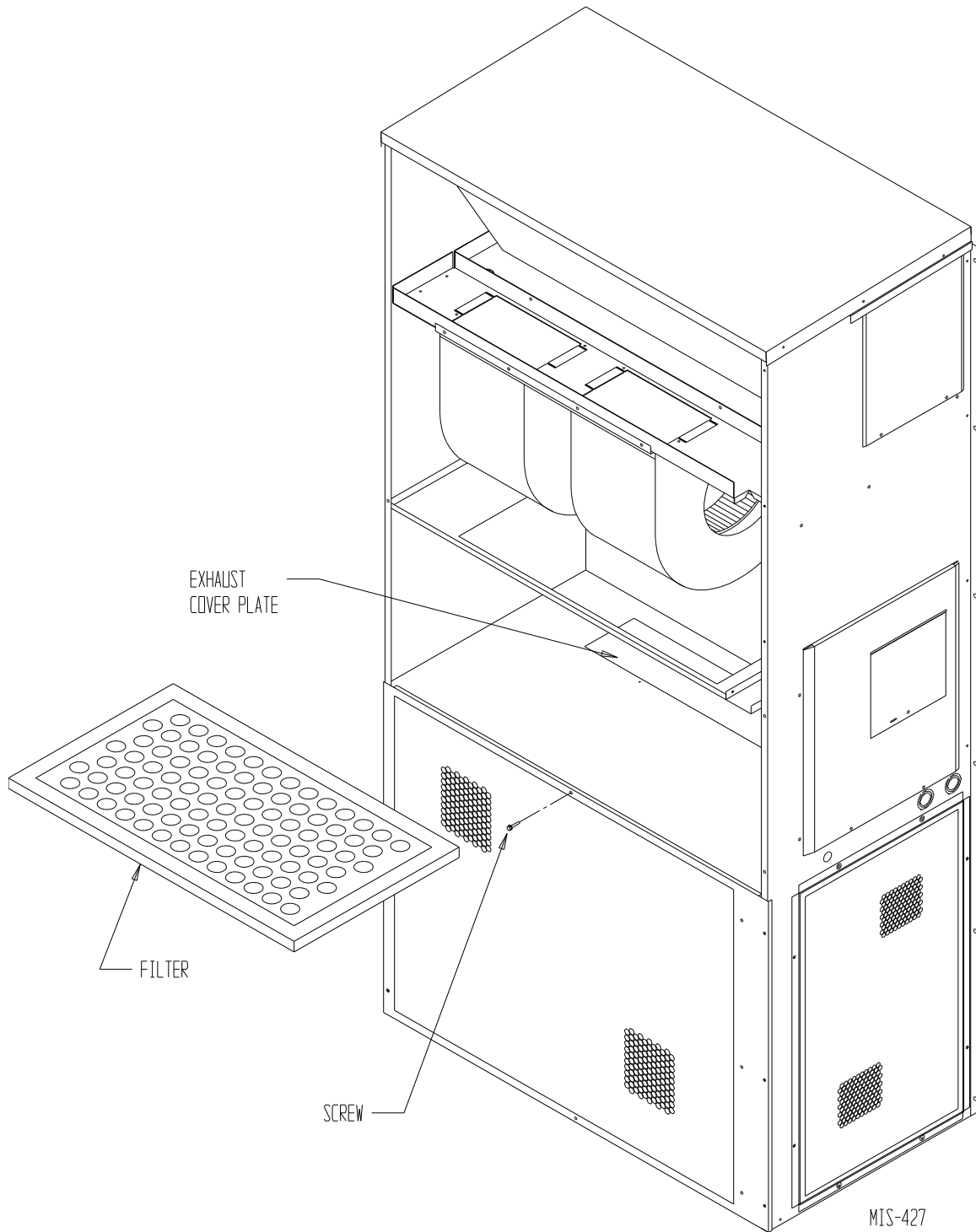

5. For Installation of Left Hand Units Only

Remove strain relief in right side of CRVS (see Figure 3). Unclip the two (2) wire ties holding the wire harness. Reroute wires to left side of CRVS. Re-install wire ties in left side holes. Route wires through left side and re-install strain relief.

6. Insert ventilator into the unit to the far left side clearing the right filter bracket (see Figure 4). Once the ventilator is fully inserted, slide the ventilator to the right until it is tight against the back of the control panel.

FIGURE 3
Reroute Wires for Left Hand CRVS-5A Units Only

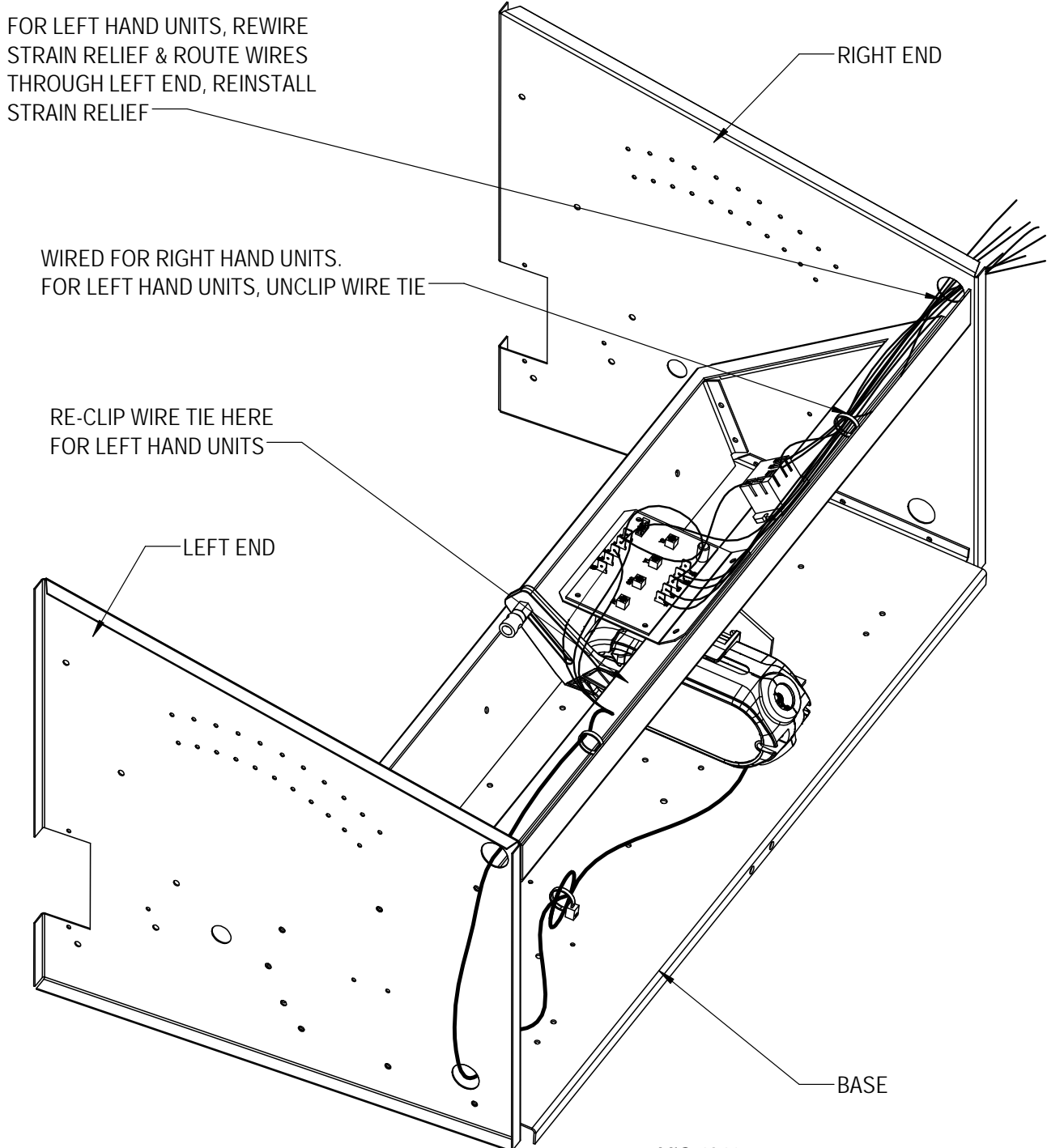

MIS-4341

IMPORTANT: Position front lip of ventilator on top of front grille and condenser partition (see Figure 4 inset). This is important to ensure proper drainage of any water entering damper assembly.

7. Open control panel to gain access to unit low voltage terminal block.
8. Route electrical harness leads through the 7/8" bushing in control panel into low voltage box as shown in Figure 4.

FIGURE 4
Install Ventilator

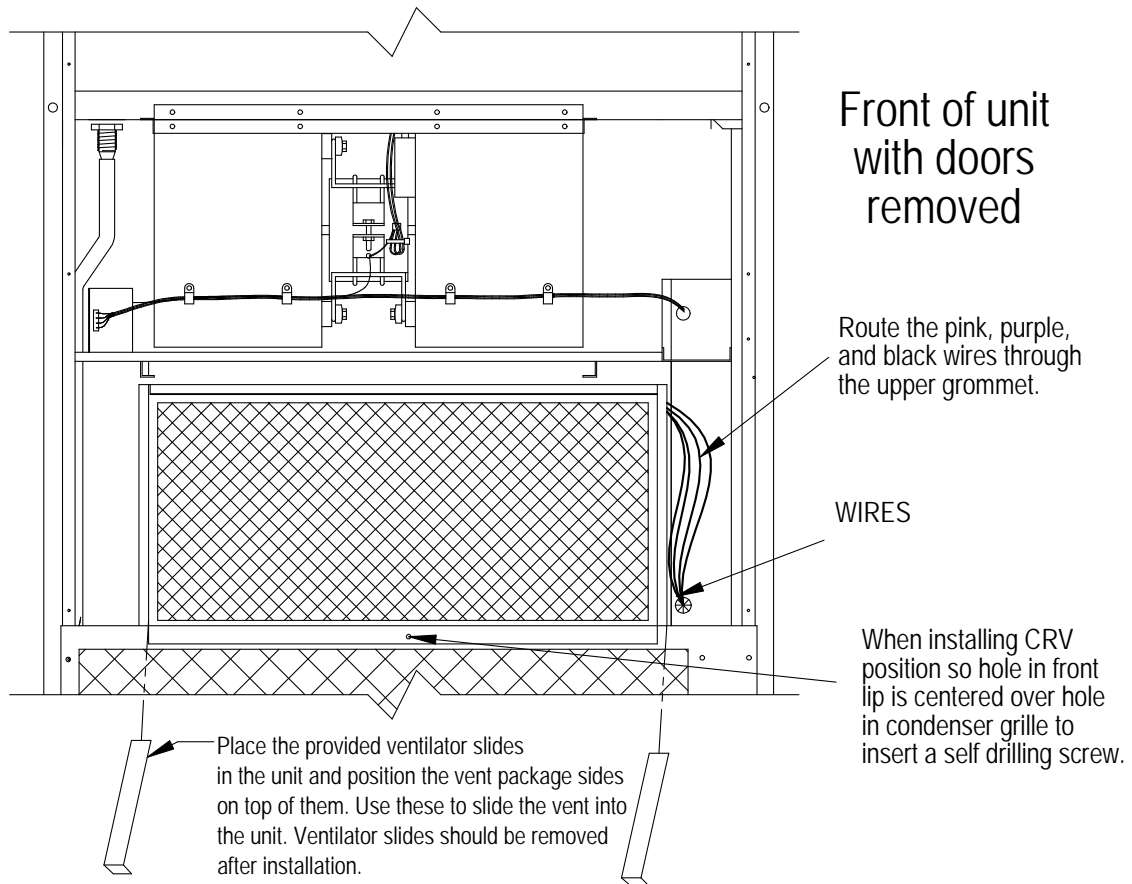

Right side of
CRV in unit

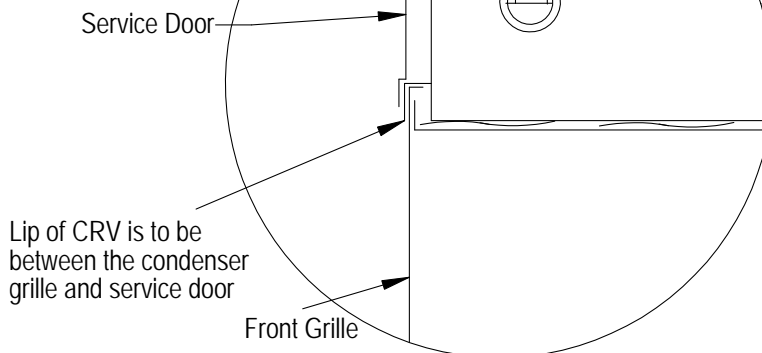

Note: Plug the (4) Ø.125 holes in the service door with canoe clips.

MIS-2030 A

9. Connect leads with fork terminals to corresponding points on unit terminal strip. (See manual 2100-507 for air conditioner connection diagrams or manual 2100-516 for heat pump connection diagrams.)
10. Close control panel cover.
11. Replace left filter support, filter and four (4) screws in condenser grille.
12. Re-install the blower access panel at top of unit and secure with sheet metal screws.
13. Ventilator checkout:
 - A. Remove mist eliminator to allow access to minimum position thumbwheel or blade stops.
 - B. Resupply power to unit.
 - C. Energize the evaporator blower by switching thermostat to the manual fan position with heat/cool in OFF position.
 - D. Ventilator should open to the position set by the OCC potentiometer on the CRV control board located on the top of the vent (see Figure 5). On the CRVS, cycle OCC potentiometer to full open through full close. Observe damper blade operation throughout travel to assure free, unobstructed movement.
 - E. De-energize evaporator blower. Damper blade should close.
 - F. This completes ventilator checkout.
14. Adjust damper blade for required ventilation airflow in blower only, stage 1, and stage 2 cooling/heating mode (see **Blade Adjustment for Desired Ventilation Air**).
15. Replace mist eliminator. Be sure it is installed with the drain holes to the bottom.
16. Remove blank off plate or barometric fresh air damper installed on service access door. Plug four (4) mounting holes with the plastic plugs provided with the ventilator.
17. Replace service access panel.
18. Ventilator is now ready for operation.

Blade Adjustment for Desired Ventilator Air

The amount of ventilation air supplied by the commercial room ventilator is dependent on four (4) factors:

1. Return air duct static pressure drop.
2. Supply air duct static pressure drop.
3. Indoor blower motor speed.
4. Damper blade open position setting.

Refer to the graph below to determine the blade setting necessary to achieve the ventilation air required for each operating mode.

Factory default settings are:

PP Potentiometer	Closed	Closed
OCC Potentiometer	B	B
Y1 Potentiometer	B	B
Y2 Potentiometer	B	B

Vent is factory set to supply between 100 and 200 CFM of fresh air in all modes of occupied operation.

For more accurate adjustment, use a flowhood over the intake opening to measure and adjust the airflow operation.

PP Potentiometer: Adjusts the airflow during pre-purge mode (If jumper is installed in positions 30-90)

OCC Potentiometer: Adjusts the airflow during blower-only operation, or during an occupied input from an applicable thermostat.

Y1 Potentiometer: Adjusts the airflow during 1st stage cooling or heating operation

Y2 Potentiometer: Adjusts the airflow during 2nd stage cooling or heating operation

Energize blower only mode and adjust OCC potentiometer to desired airflow.

Energize 1st stage cooling mode and adjust Y1 potentiometer to desired airflow.

Energize 2nd stage cooling mode and adjust Y2 potentiometer to desired airflow.

If pre-purge mode is desired, de-energize cooling modes. Move PP jumper to the 30-, 60-, or 90-minute position and adjust PP potentiometer to desired airflow.

Minimum damper position when using CO₂ control damper should be fully closed at 700 ppm or lower, if not potentiometer OCC can be adjusted counter-clockwise (CCW) to close it. If it is fully closed at 700 ppm or lower, no adjustments required.

FIGURE 5
CRV Control Board

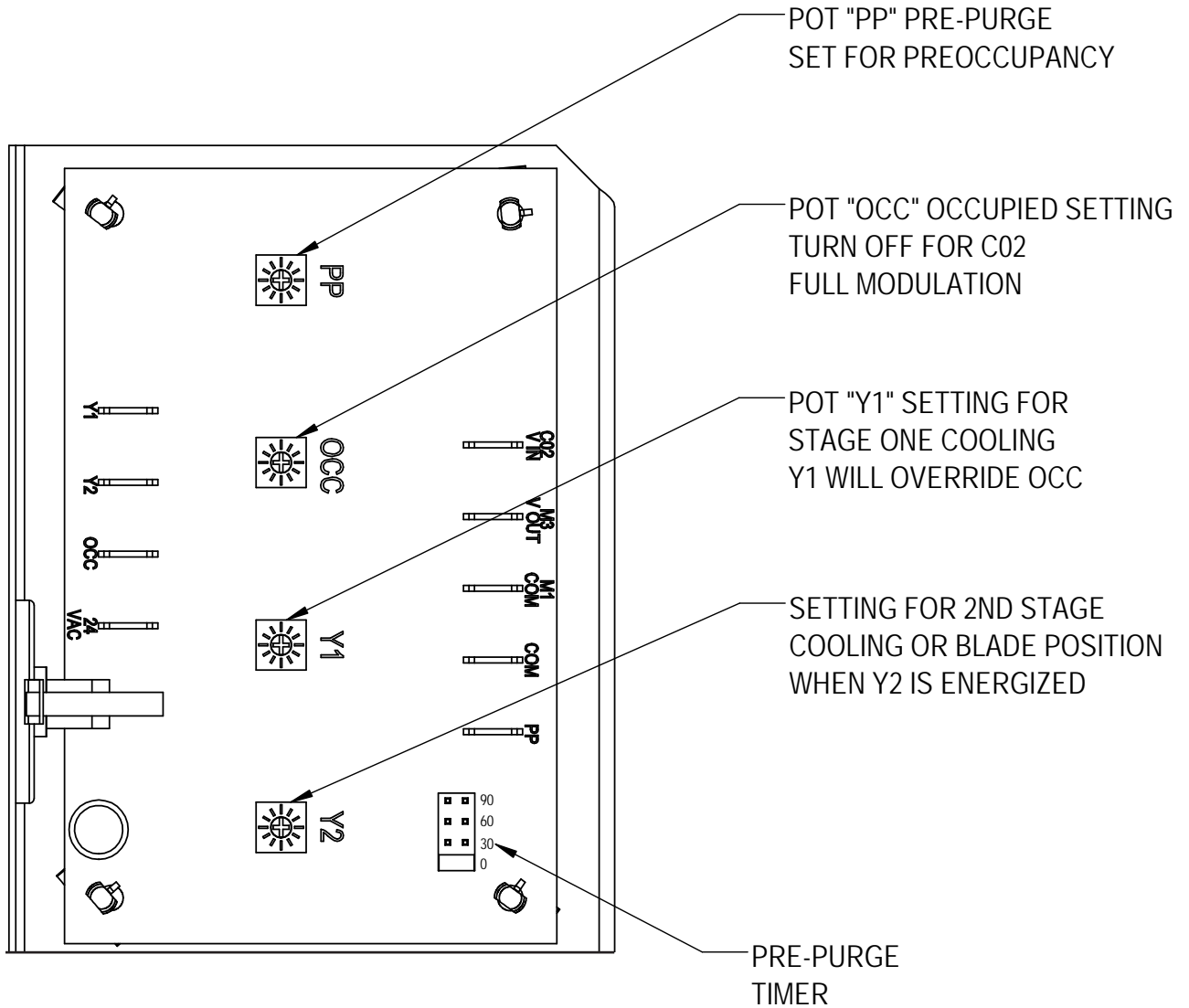

MIS-4047

"V" Option CRV Sequence of Operation

The "V" Ventilation option includes a control board with blade positioning potentiometers along with an input for a 2-10V input signal (see Figure 6).

Adjustable potentiometers:

"PP" Potentiometer setting: This potentiometer can be used to adjust the blade setting for outdoor air intake during a pre-purge cycle. The pre-purge cycle time is based on the setting of the pre-purge timer.

"OCC" Potentiometer setting: This potentiometer can be used to adjust the blade setting for outdoor air intake when the "01" terminal is energized on the low voltage terminal strip indicating occupancy.

"Y1" Potentiometer setting: This potentiometer can be used to adjust the blade setting for outdoor air intake when the "Y" terminal is energized on the low voltage terminal strip indicating 1st stage cooling or Balanced Climate operation. When energized, it overrides the "OCC" potentiometer setting.

"Y2" Potentiometer setting: This potentiometer can be used to adjust the blade setting for outdoor air intake when the "Y1" terminal is energized on the low voltage terminal strip indicating 2nd stage cooling operation. When energized, it overrides the "OCC" and "Y1" potentiometer settings.

Pre-Purge Feature

Pre-purge is used to ventilate a specified CFM amount before occupants enter the room or structure. The control board has a built-in pre-purge timer that can be set to 30-, 60- and 90-minute intervals by moving the jumper noted in Figure 5 on page 9. This timer will start when the jumper is installed and the "01" terminal is energized on the low voltage terminal strip. Blade adjustment can be made on the PP potentiometer. Once the timer has timed out, the board will default to the occupied setting and this blade position can be adjusted on the OCC potentiometer. If the timer is set to 0 (off—shipped position), the occupied setting is instantaneous and the pre-purge setting (PP) is no longer in the sequence.

Occupied Setting

Occupied is used to ventilate a specified CFM amount when occupants enter the room or structure. The control board will energize the occupied setting after the pre-purge cycle, or if pre-purge is disabled immediately when the "01" terminal is energized on the low voltage strip. Blade adjustment can be made on the OCC potentiometer.

Y1 Setting

Y1 is used to ventilate a specified CFM amount when Y cooling is energized. The control board will energize the Y1 setting when Y is energized on the low voltage strip. Blade adjustment can be made on the Y1

FIGURE 6
CRV Control Board

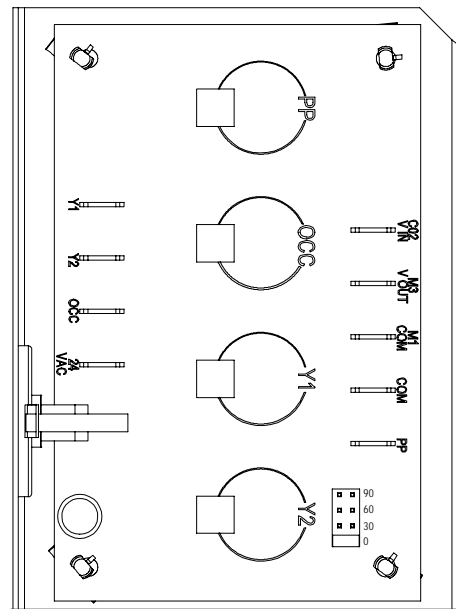

potentiometer. This potentiometer setting overrides the OCC occupied setting.

Y2 Setting

Y2 is used to ventilate a specified CFM amount when Y1 cooling is energized. The control board will energize the Y2 setting when Y1 is energized on the low voltage strip. Blade adjustment can be made on the Y2 potentiometer. This potentiometer setting overrides the OCC occupied and the Y1 setting.

2-10V Operation

A CO₂ sensor or other device sending a 2-10V signal can be used to control the damper motor. Two control methods are available to control the damper motor:

- Method 1: The control board will accept a 2-10VDC signal with a resistive load greater than 5000 ohms. Bard CO₂ sensor 8403-096 can be used when the 2-10V output is connected to the blade connector on the unlanded gray wire from the CRV, located near the unit low voltage terminal strip. The occupied OCC potentiometer setting must be set to the off position for total modulation. The OCC potentiometer can be used to maintain a minimum blade position when "01" is energized.
- Method 2: The damper motor will accept a 2-10VDC signal with a resistive load less than 5000 ohms. This method involves bypassing the control board and powering the motor directly from the device providing the 2-10VDC modulating signal. The gray wire connected to CO₂ VIN on the control board must be spliced with the white wire

ran to the damper motor (OUT on control board).
The other end of the gray wire should be connected
to the CO₂ sensor as stated in Method 1.

During 2-10VDC operation with "01" energized and
pre-purge timed operation active, DC voltage signaling
occupancy from a source such as a CO₂ sensor will
increase ventilation amounts as needed.

FIGURE 7
8403-096 CO₂ Sensor Set Up

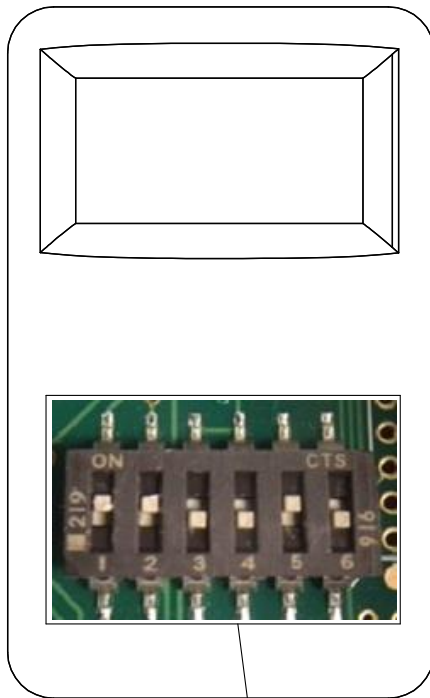

PRESS UP AND DOWN ARROWS TO ENTER CONFIGURATION MODE. USE ARROWS TO SELECT SETTING. PUSH MIDDLE BUTTON TO CHANGE. CONTROLLER WILL SHOW SET.

NOTE: MENU DIP SWITCH MUST BE IN "ON" POSITION #5 TO CHANGE ANY SETTINGS WITH THE SIDE BUTTONS. TO LOCK THE CO2 CONTROLLER MOVE DIP SWITCH TO "OFF" AFTER IT HAS BEEN CONFIGURED.

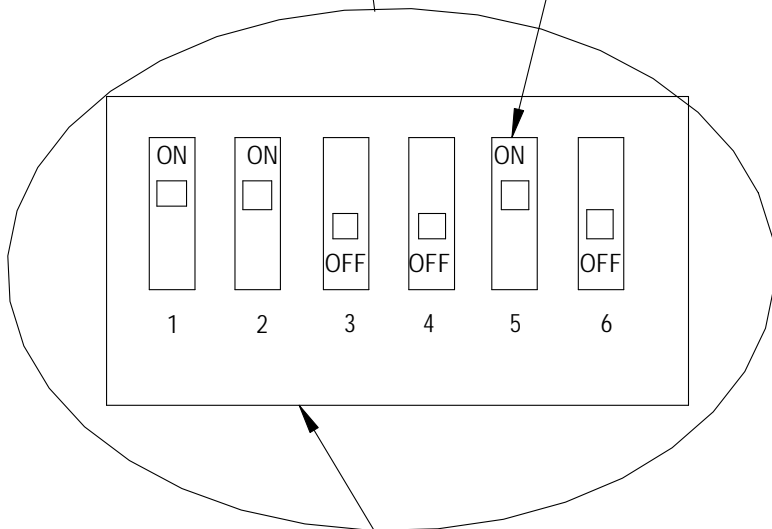
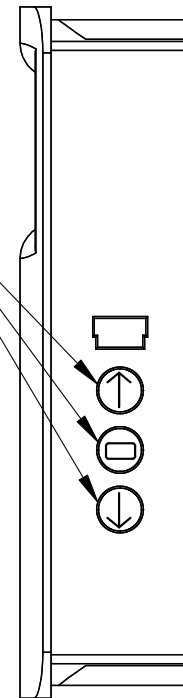

DIP SWITCHES MUST BE POSITIONED AS SHOWN FOR PROPER OPERATION

Settings	Recommended	Default
RON (RELAY ON SET POINT)	725	
ROF (RELAY OFF SET POINT)	700	
DSP (DISPLAY CONFIGURATION)	C	CT
UNI (UNITS SELECTION)	US	US
COL (CO2 LOW OUTPUT RANGE)	700	0
COH (CO2 HIGH OUTPUT RANGE)	1500	2000
TOL (TEMP. LOW OUTPUT RANGE)	Not Used	
TOH (TEMP. HIGH OUTPUT RANGE)	Not Used	
BAR (BAROMETRIC PRESSURE)	See Instructions with Controller For High Altitude Installations	
CAL (CALIBRATION)	Used for Field Calibration	

MIS-4025 C

FIGURE 8
CRV Control Board Wiring

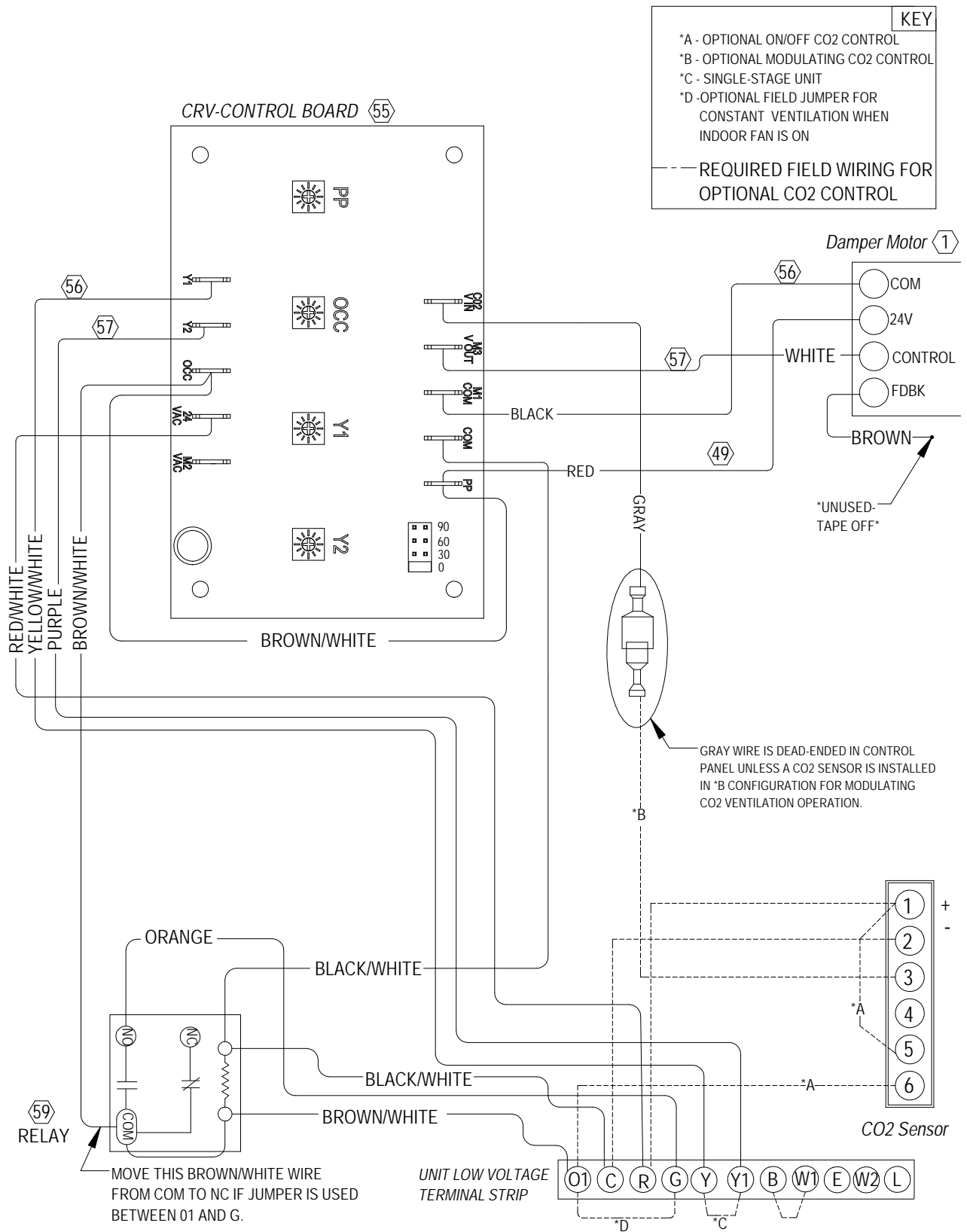

GRAPH 1
Commercial Room Ventilator Performance Data: T36 with CRVS-5A

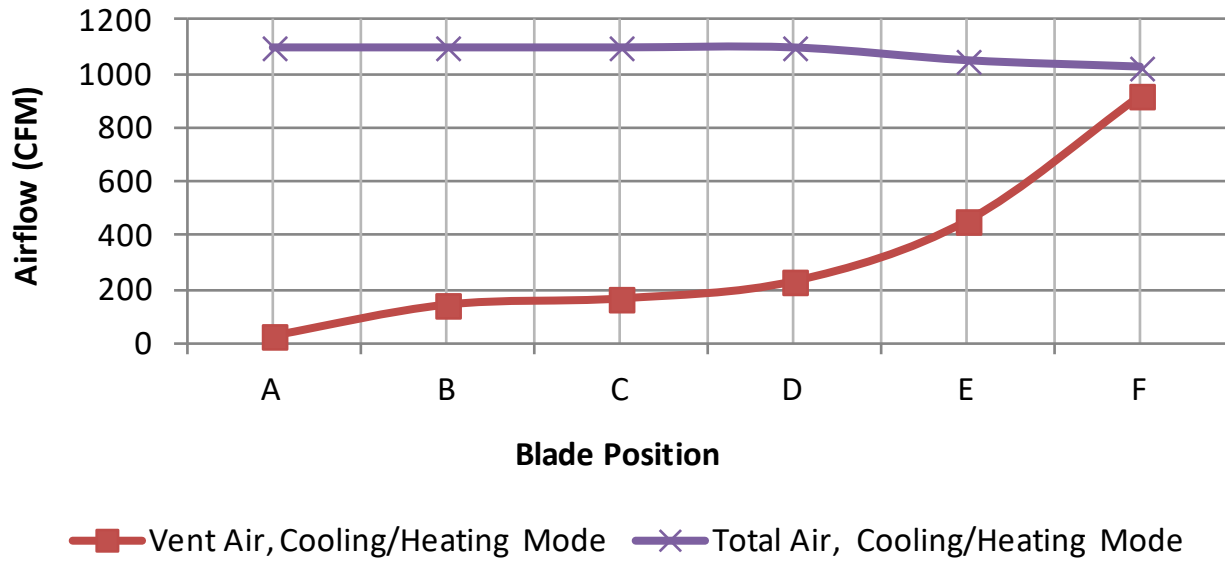

GRAPH 2
Commercial Room Ventilator Performance Data: T42 with CRVS-5A

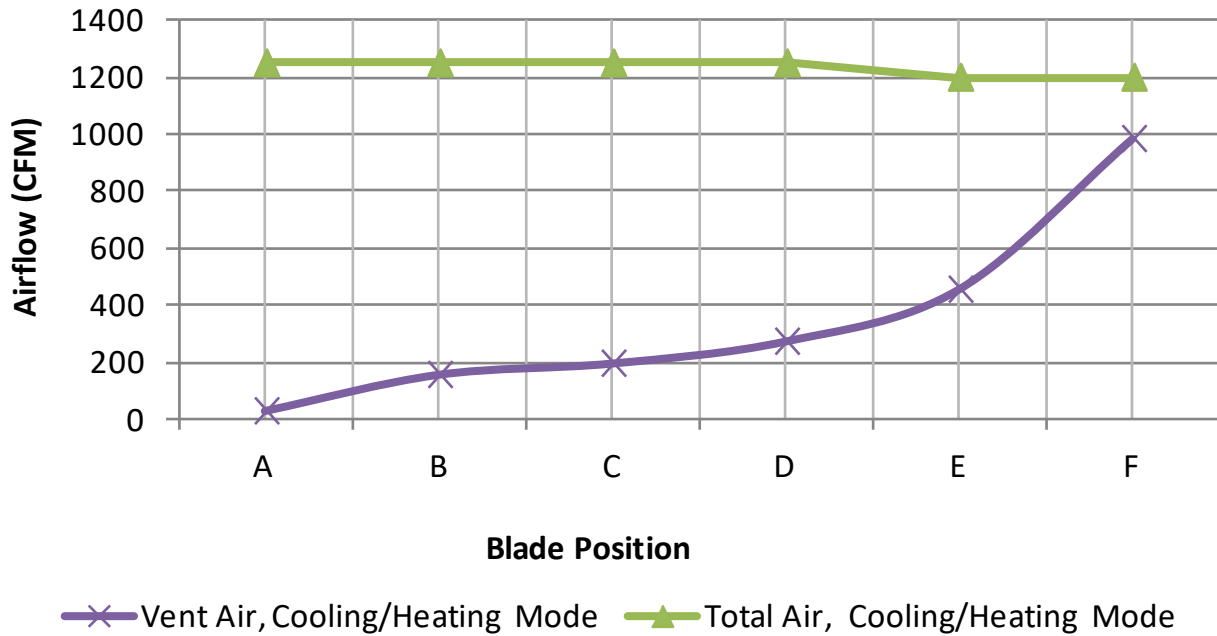

GRAPH 3
Commercial Room Ventilator Performance Data: T48 with CRVS-5A

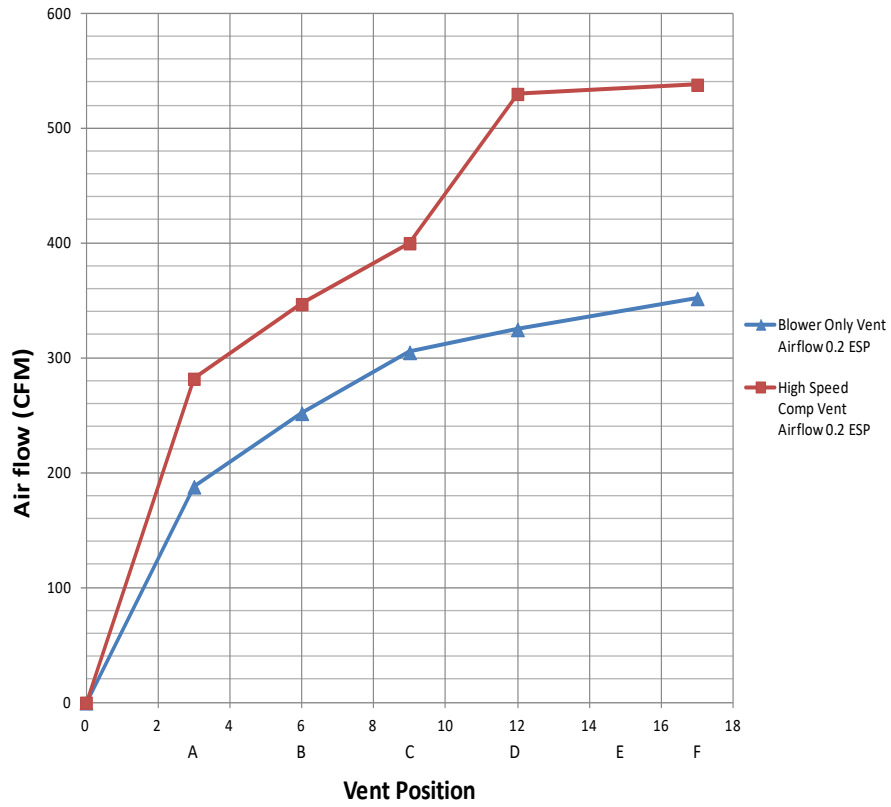

GRAPH 4
Commercial Room Ventilator Performance Data: T60 with CRVS-5A

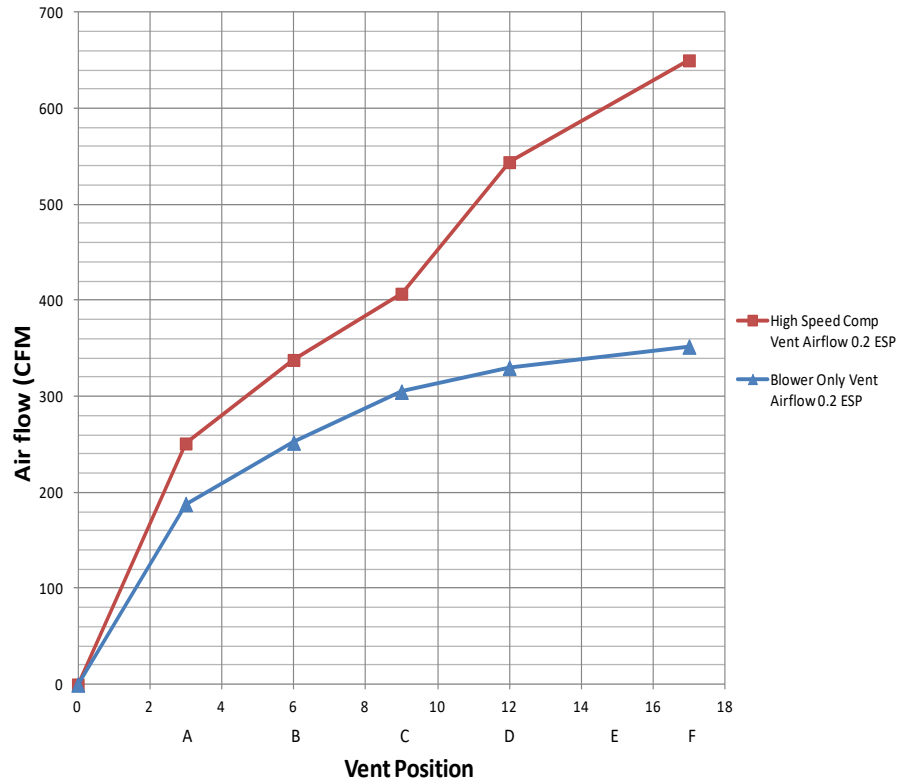
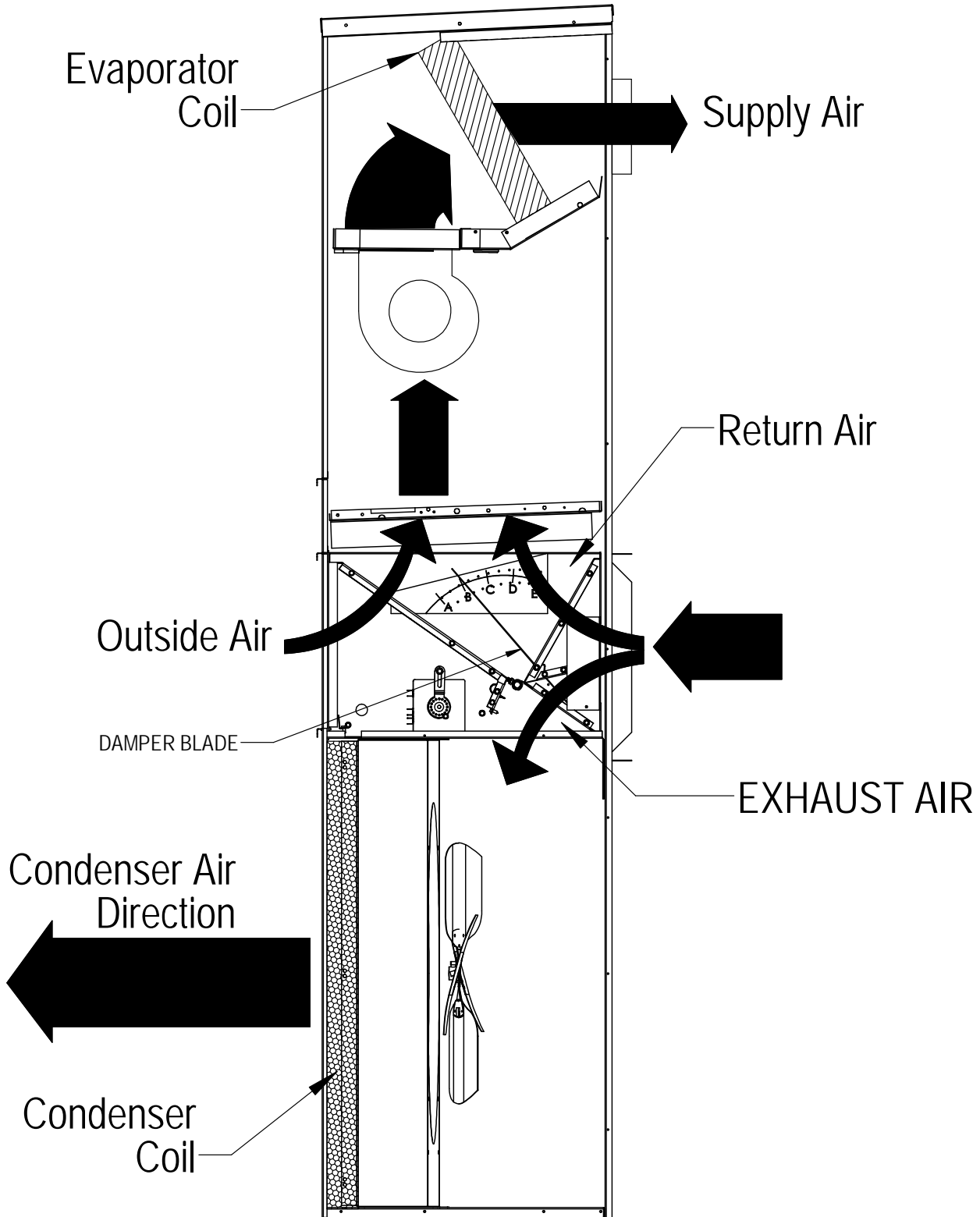
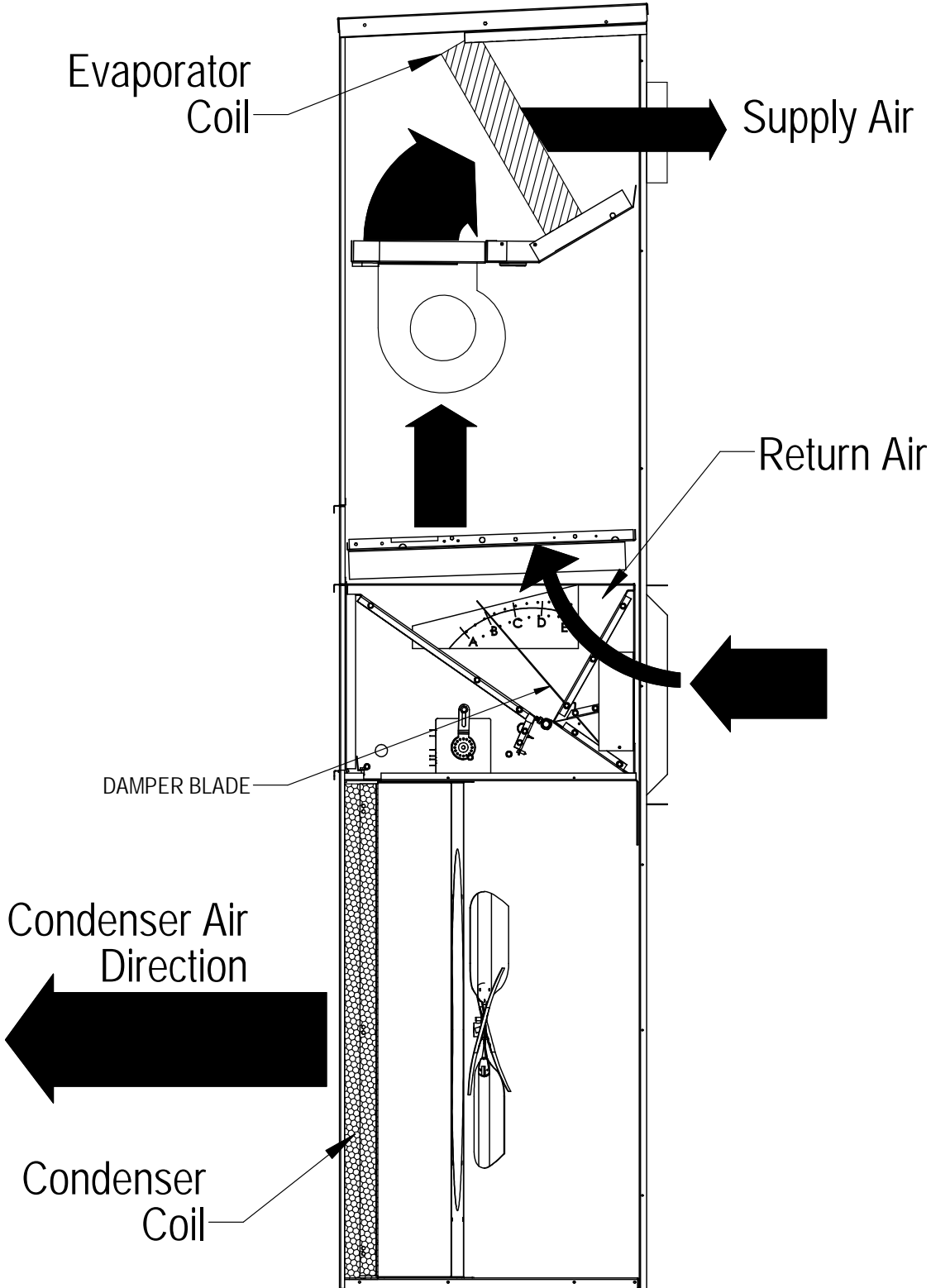

FIGURE 9
Call for Blower Operation



MIS-347A

FIGURE 10
Call for Compressor or Fan Only
with Ventilation Off



MIS-348A