

---

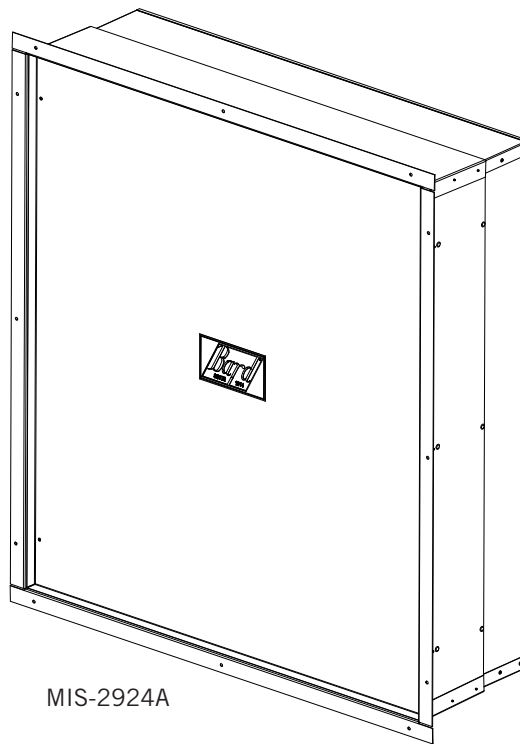
# INSTALLATION INSTRUCTIONS

---

## IZ Series I-TEC® Wall Sleeve for 1" and 2" Louvers

Models:

IZWS-A    IZWS-B    IZWS-C



MIS-2924A



*Climate Control Solutions*

Bard Manufacturing Company, Inc.  
Bryan, Ohio 43506  
[www.bardhvac.com](http://www.bardhvac.com)

Manual: 2100-776  
Supersedes: **NEW**  
Date: 2-27-23

# CONTENTS

---

**Getting Other Information and Publications** 3

**I-TEC Wall Sleeve General Information**

- Shipping Damage ..... 4
- General ..... 4
- Unpacking ..... 4
- Side Angle Relocation for ILA-2 Louver..... 4

**Installation**

- Installation – Wood Framed Walls..... 6
- Installation – Masonry Construction Walls ..... 7
- Attachment of Wall Sleeve to I-TEC Unit..... 8

**Figures**

- Figure 1 IZWS-\* Wall Sleeve Dimensions..... 4
- Figure 2 I-TEC and Wall Sleeve ..... 5
- Figure 3 Side Angle Relocation ..... 5
- Figure 4 Wood Framed Installation..... 6
- Figure 5 Application of Sealant to Flanges..... 7
- Figure 6 Masonry Construction Installation ..... 7
- Figure 7 Typical Installation ..... 8
- Figure 8 Blank-Off Plate ..... 9
- Figure 9 Attachment of Wall Sleeve ..... 10

## **GETTING OTHER INFORMATION AND PUBLICATIONS**

---

The following publications can help when installing the wall sleeve. They can usually be found at the local library or purchased directly from the publisher. Be sure to consult the current edition of each standard.

Standard for the Installation of Air Conditioning and Ventilating Systems.....ANSI/NFPA 90A

Standard for Warm Air Heating and Air Conditioning Systems .....ANSI/NFPA 90B

In addition, it may be helpful to consult the latest revision of I-TEC Installation Instructions manual 2100-770.

For more information, contact these publishers:

**ACCA**      **Air Conditioning Contractors of America**  
1712 New Hampshire Ave. N.W.  
Washington, DC 20009  
Telephone: (202) 483-9370  
Fax: (202) 234-4721

**ANSI**      **American National Standards Institute**  
11 West Street, 13th Floor  
New York, NY 10036  
Telephone: (212) 642-4900  
Fax: (212) 302-1286

**ASHRAE**    **American Society of Heating, Refrigeration and Air Conditioning Engineers, Inc.**  
1791 Tullie Circle, N.E.  
Atlanta, GA 30329-2305  
Telephone: (404) 636-8400  
Fax: (404) 321-5478

**NFPA**      **National Fire Protection Association**  
Batterymarch Park  
P.O. Box 9101  
Quincy, MA 02269-9901  
Telephone: (800) 344-3555  
Fax: (617) 984-7057

# I-TEC WALL SLEEVE GENERAL INFORMATION

## Shipping Damage

Upon receipt of equipment, the carton should be checked for external signs of shipping damage. If damage is found, the receiving party must contact the last carrier immediately, preferably in writing, requesting inspection by the carrier's agent.

## General

The IZWS-\* Series wall sleeve is designed for use with the I-TEC IZ2 Series heat pump. The wall sleeve assembly consists of a large intake sleeve and a smaller exhaust sleeve. Both sleeves are telescoping to adjust for different wall depths. See Figures 1 and 2.

Wall Sleeve Model Number	Wall Thickness	Standard Louver Depth
IZWS-A	5.5" - 8"	1"
IZWS-B	8" - 13.5"	1"
IZWS-C	13" - 23.5"	1"

These instructions explain the recommended method to install the wall sleeve. The equipment covered in this manual is to be installed by trained service and installation technicians.

These instructions and any instructions packaged with any separate equipment required to make the entire air conditioning system should be carefully read before beginning the installation.

While intended as a general recommended guide, these instructions do not supersede any national and/or local codes in any way. Authorities having jurisdiction should be consulted before the installation is made.

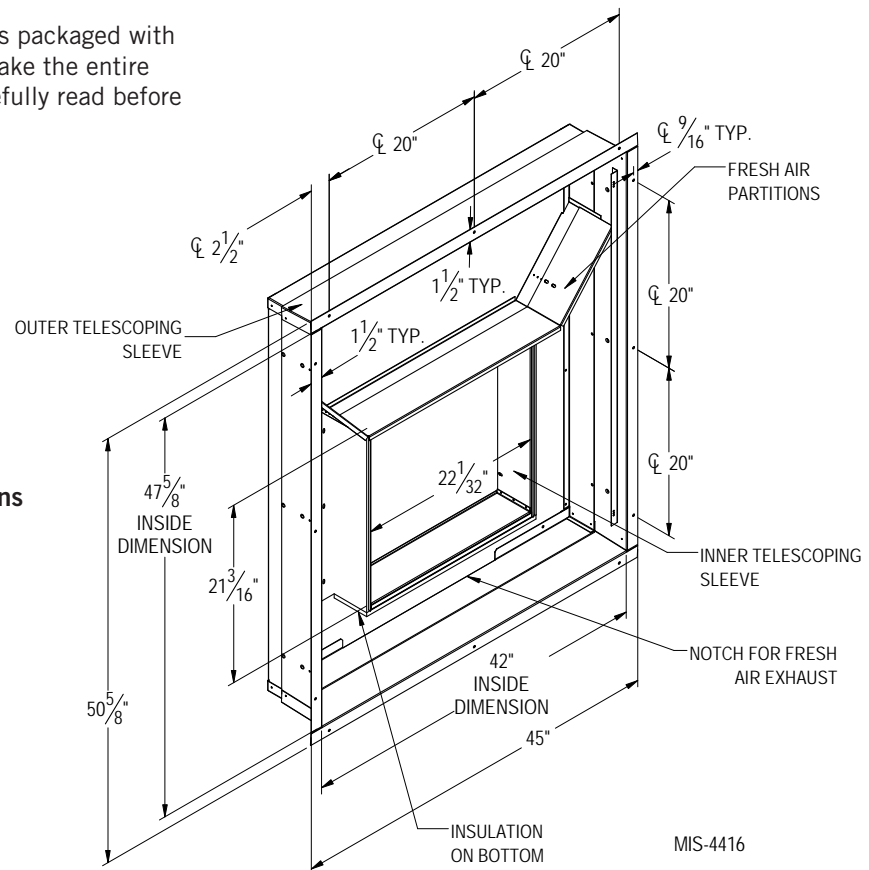
## Unpacking

1. The smaller exhaust sleeve and fresh air partition is attached to the weatherization plate with four (4) screws for shipping. Remove these screws (throw away) and set the exhaust sleeve assembly aside.
2. Remove the inner telescoping sleeve (with the rubber gasket) from larger inlet sleeve and set it aside.
3. Remove inlet sleeve, with weatherization plate attached, from the carton and turn over.
4. Remove and save the four (4) screws attaching the security plate.

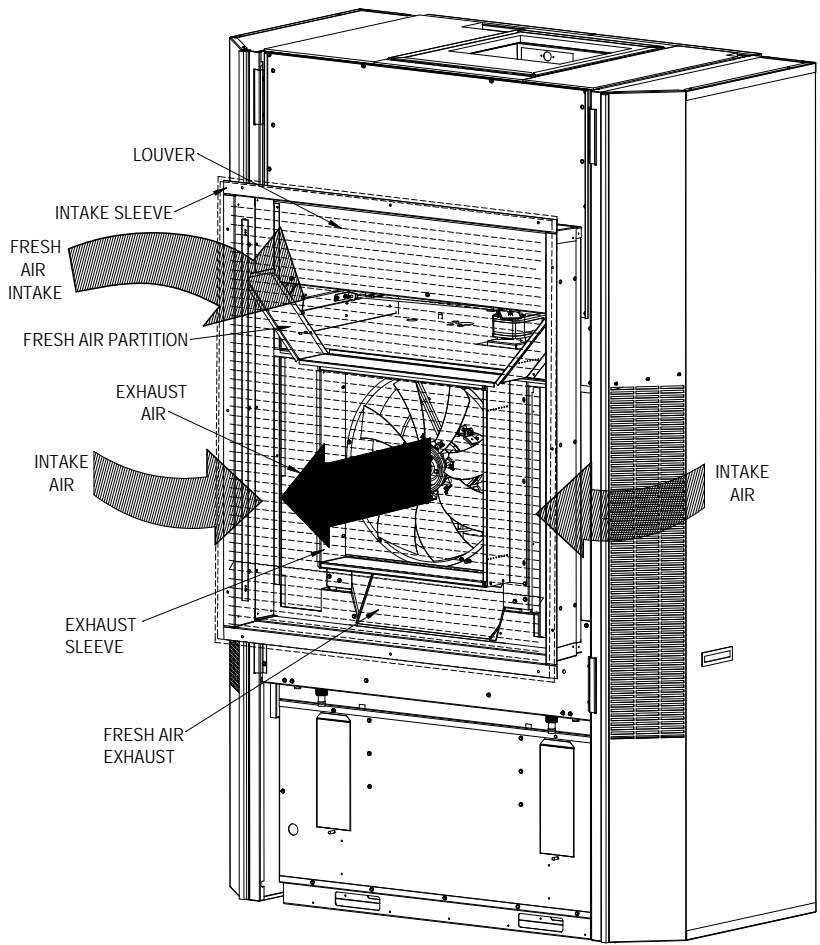
## Side Angle Relocation for ILA-2 Louver

The IZWS-\* wall sleeve is designed for use with both 1" and 2" louver depths. As shipped, the sleeve is ready for 1" louver installation. Refer to Figure 3 for angle installation instructions for 2" louver depth.

FIGURE 1  
IZWS-\* Wall Sleeve Dimensions

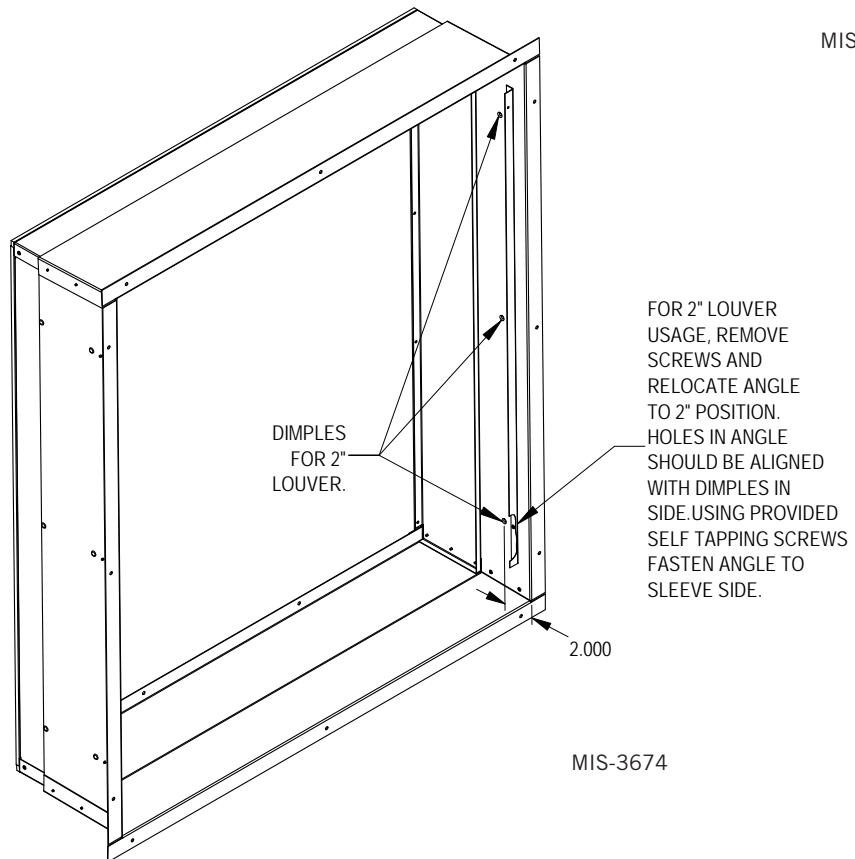


**FIGURE 2**  
**IZ2 Series I-TEC and Wall Sleeve**  
**(Back of Unit)**



MIS-4417

**FIGURE 3**  
**Side Angle Relocation**



MIS-3674

## Installation – Wood Framed Walls

For wood frame construction walls, the minimum dimensions of the opening must be 48" tall by 42-3/4" inches wide. A 2 x 6 header will be required for the opening. The sides of the opening must have trimmer studs to support the header and to provide a structural member on which to fasten the sleeve (see Figure 4). All of the dimensions are referenced from the finished floor height. If a riser platform accessory is used, adjust dimensions accordingly.

Once the opening is framed, the sheeting can be installed but the sheeting material must not extend into the opening.

The intake sleeve should be test fit into the opening to make sure of the dimensions. The sleeve must be inserted into the opening from the outside of the building. The bottom of the sleeve must be level from side to side and the sleeve must be square in the opening. A slope is built into the bottom of the sleeve from the inside to the outside. This will allow any water that gets into the sleeve to drain out. Once the test fit is completed, the sleeve must be removed from the opening, and two 1/4" beads of sealant must be applied to the mounting flanges of the sleeve (see Figure 5).

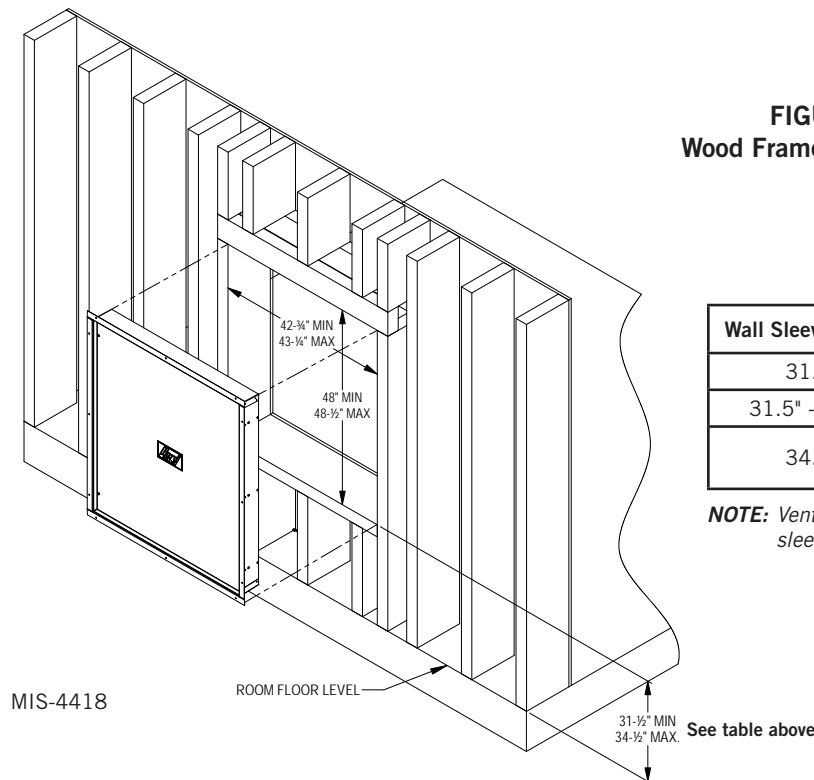
The sleeve is then re-inserted into the prepared opening from the outside of the building. All of the mounting flanges must contact the exterior wall. Check to see that there is enough sealant to make this joint watertight. Additional sealant must be applied as necessary. The

sleeve must be centered in the opening and the bottom of the sleeve must be checked to make certain that it is level from side to side. The bottom flange should be secured to the wall by using two (2) field-supplied wood screws through the holes in the bottom mounting flange of the sleeve. The sleeve must be checked to make sure that it is square in the opening. Once the sleeve is square, the side and top mounting flanges of the sleeve must be secured to the wall with ten (10) field-supplied wood screws through the holes in the flanges.

The inner portion of the intake sleeve must be inserted from the inside of the building. **The side on the sleeve with the notch is the bottom of the sleeve (see Figure 1).** While holding the flanged side of the sleeve, slide it into the outer sleeve and insert far enough so it projects approximately 1/2" from either the smooth wall surface or from the sill. Final adjustment must be done from the outside.

On the inside of the building, the gaps between the sleeve and the rough wall opening must be filled with insulation.

**NOTE:** If foamed insulation is used, the final location of the inner sleeve must be determined since the foam insulation could lock the inner sleeve into an incorrect location causing either an air leak between sleeve and back of unit or preventing the unit from going as tight to the wall or sill as desired. This must be done before the unit is placed and before the inner portion of the intake sleeve is secured with screws to the outer sleeve. Insulating this space will prevent infiltration of any unwanted outside air (see Figure 7 on page 8).

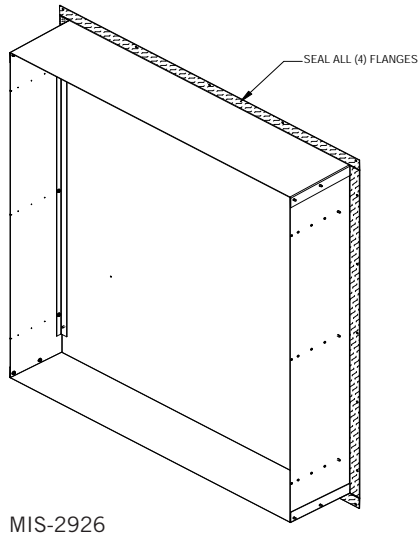


**FIGURE 4**  
**Wood Framed Installation**

Wall Sleeve Height	
31.5"	Standard Installation
31.5" - 34.5"	Vent Blank-Off Plate is Required
34.5"	3" Riser Kit or the Vent Blank-Off Plate is Required

**NOTE:** Vent blank-off plate included with IZWS-\* sleeves.

**FIGURE 5**  
Application of Sealant to Flanges



If the I-TEC unit will be drained through the wall, the drain line must be installed prior to setting the unit. Information for the drain installation is provided in the installation manual supplied with the unit. At this point, the following are options:

1. Install the weatherization plate, if the I-TEC unit is not ready to be installed.

**NOTE:** *The exhaust sleeve attaches to the I-TEC unit. Store it and any remaining mounting hardware in a safe location.*

2. Proceed with attachment of wall sleeve to I-TEC unit (see page 8).

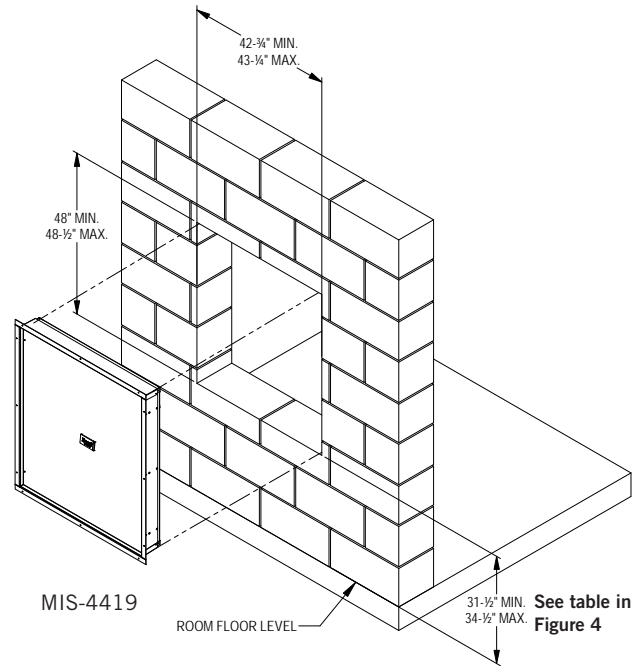
## Installation – Masonry Construction Walls

For masonry construction walls, the minimum dimensions for the opening will be 48" tall by 42-3/4" wide. These dimensions are measured from the finished floor height (see Figure 6). These will be the finish dimensions of the opening.

The sleeve should be test fit in the opening before final preparations are made. The sleeve will be installed into the opening from the outside of the building in. The sleeve must be centered in the opening from side to side. The mounting flanges of the sleeve must contact the outside wall all around the opening. The side and top mounting flanges must have the mounting holes drilled into the outside wall for the concrete anchors which will hold the sleeve in the wall.

The holes should be drilled through the holes in the sleeve with the sleeve level and square in the opening. A slope is built into the bottom of the sleeve from the inside to the outside. This will allow any water that gets into the sleeve to drain out. Once the test fitting has

**FIGURE 6**  
Masonry Construction Installation



been checked out, the sleeve should be removed from the wall.

With the sleeve removed, two 1/4" beads of sealant must be applied to the flanges that contact the outside wall (see Figure 5).

The sleeve must be installed back in the wall making sure that the predrilled holes in the wall line up with the holes in the mounting flanges of the sleeve. Check to make sure that there is enough sealant between the wall and the flanges to make the joint watertight. Additional sealant must be applied as required. The sleeve must be anchored to the wall. All four mounting flanges must be fastened to the outside wall using twelve (12) field-supplied masonry screws.

The inner portion of the intake sleeve must be inserted from the inside of the building. While holding the flanged side of the sleeve, slide it into the outer sleeve and insert far enough so it projects approximately 1/2" from either the smooth wall surface or from the sill. Final adjustment must be done from the outside.

On the inside of the building, the gaps between the sleeve and the rough wall opening must be filled with insulation.

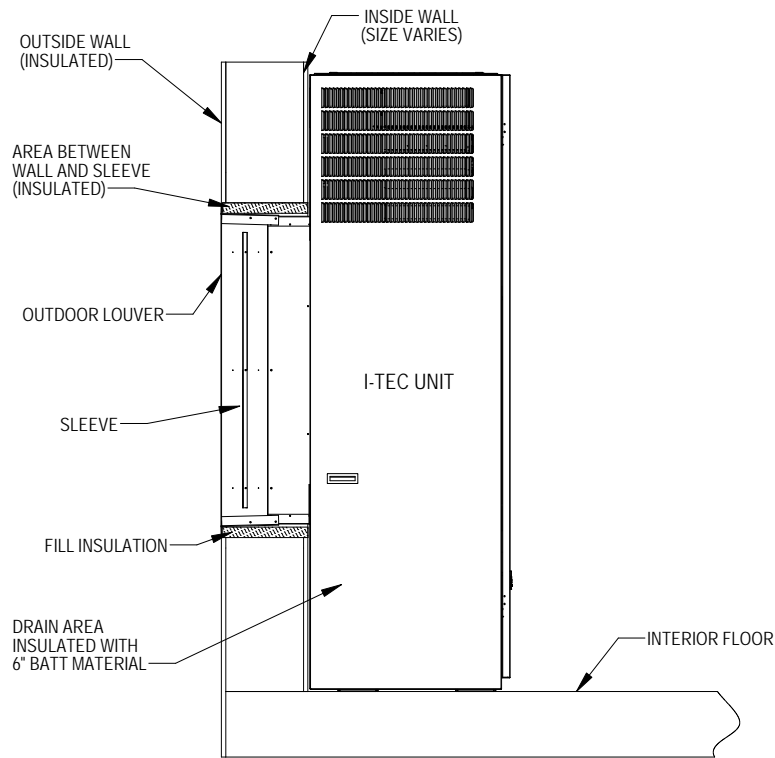
**NOTE:** *If foamed insulation is used, the final location of the inner sleeve must be determined since the foam insulation could lock the inner sleeve into an incorrect location causing either an air leak between sleeve and back of unit or preventing the unit from going as tight to the wall or sill as desired. This must be done before the unit is placed and before the inner portion of the*

intake sleeve is secured with screws to the outer sleeve. Insulating this space will prevent infiltration of any unwanted outside air (see Figure 7).

If the I-TEC unit will be drained through the wall, the drain line must be installed prior to setting the unit. Information for the drain installation is provided in the installation manual supplied with the unit. At this point, the following are options:

1. Install the weatherization plate if the I-TEC unit is not ready to be installed.  
**NOTE:** The exhaust sleeve attaches to the I-TEC unit. Store it and any remaining mounting hardware in a safe location.
2. Proceed with attachment of wall sleeve to I-TEC unit (see below).

**FIGURE 7**  
**Typical Installation**



MIS-2928C

### Attachment of Wall Sleeve to I-Tec Unit

Before attaching the wall sleeve to the unit, measure the distance from the wall sleeve opening to the floor. If the wall sleeve opening is more than 31.5" from the floor, the exhaust blank-off plate must be installed. Remove the two (2) screws from the exhaust duct. While lifting the exhaust blade, install the blank-off plate (see Figure 8).

Move the unit into place ensuring it is aligned side to side. Push it back until the side panels are flush with the wall or until the sides contact the window sill—if that is the case. From the outside of the building, push the inner sleeve inward until the foam gasket contacts the unit. Attach the sleeve to the rear of the I-TEC using the twelve (12) 3/4" long self-tapping screws supplied with the sleeve (see Figure 9 on page 10, Ref. B).

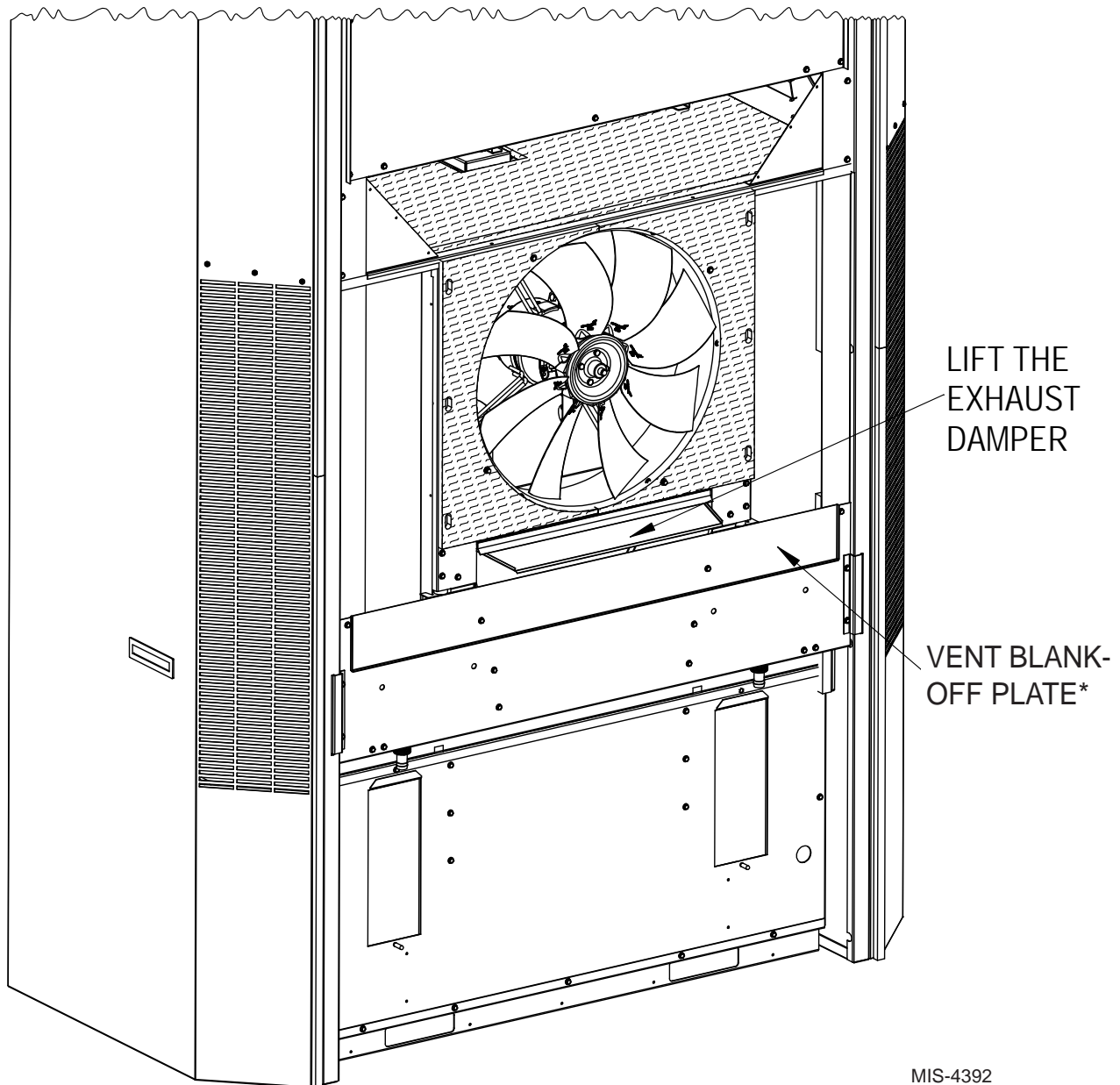
Tie the inner and outer sleeves together with the three (3) 3/4" long self-tapping screws on each side (Figure 9, Ref. A). Apply a bead of caulk to the entire perimeter seam between the inner and outer sleeves as shown Figure 9, Ref. A.

The exhaust sleeve has three (3) screw slots in each side flange. Line these up with the screw engagement holes in the fan panel, the side without insulation going on top. Attach using six (6) 3/4" long sheet metal screws supplied with the sleeve (see Figure 9, Ref. C). Extend the sleeve out until it is flush with the louver attachment angles. Lock the sleeve in place using two (2) 1/2" long sheet metal screws on each side by shooting through the slot into a pre-punched hole (Figure 9, Ref. D). The fresh air partition fastens with six (6) 1/2" long sheet metal screws to the triangle-shaped brackets on the fresh air partition. Extend the



second partition out until it is flush with the louver attachment angles, locking it into place with four (4) 1/2" long sheet metal screws. Use 1-1/2" long screws (supplied) to attach louver to outer sleeve (see Figure 9, Ref. E).

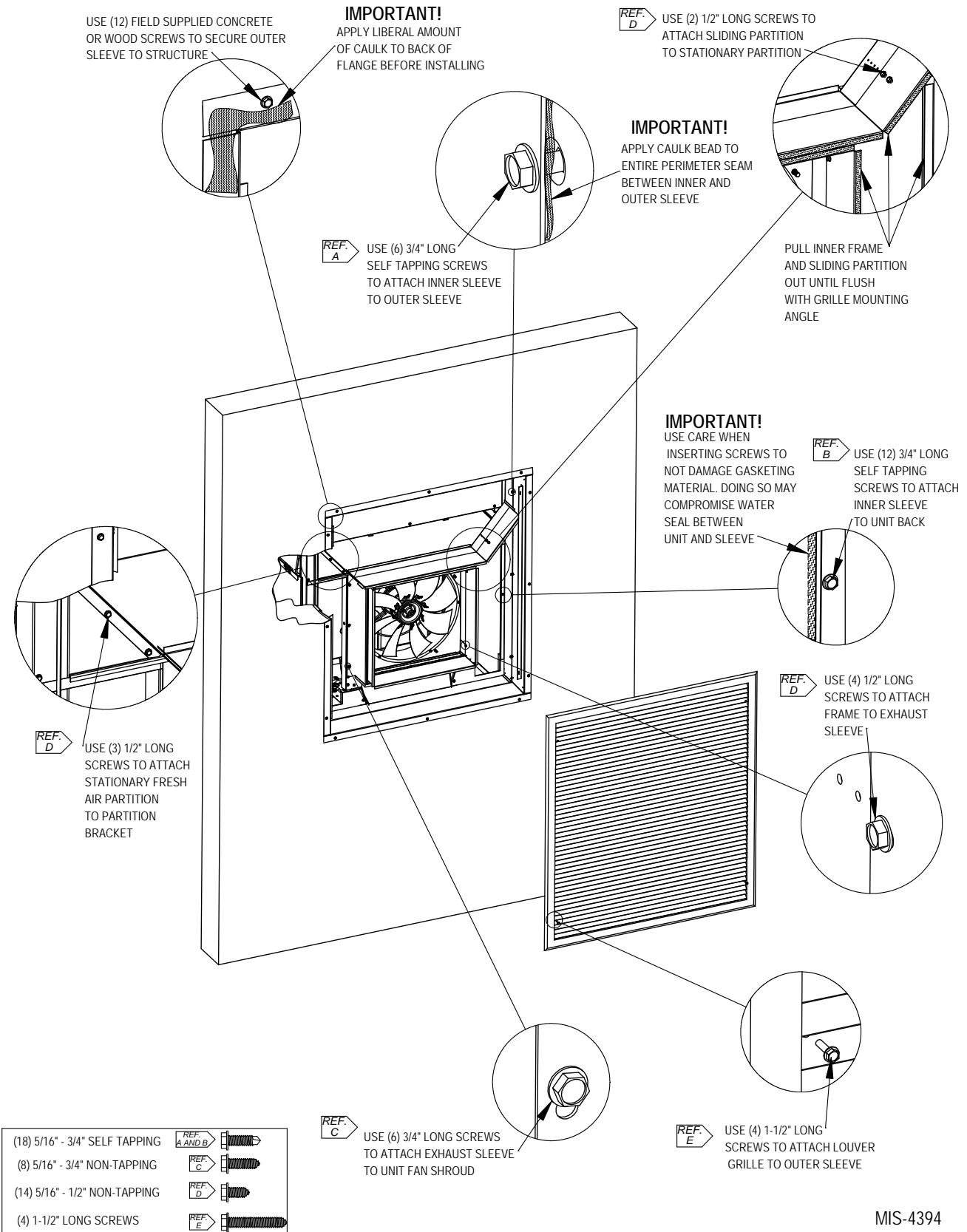
**FIGURE 8**  
**Blank-Off Plate**



MIS-4392

- The vent blank-off plate reduces the exhaust air amount. For units with CRV packages, the vent blank-off plate is not recommended for applications where positive pressurization of the room is not acceptable. In units with an economizer, the exhaust blower's airflow can be adjusted to maintain an acceptable room pressure. However, this will increase the sound levels of the unit. (Reference vent installation manual for this adjustment.)

**FIGURE 9**  
**Attachment of Wall Sleeve**



MIS-4394