

---

# INSTALLATION INSTRUCTIONS

---

## Electric Heat Packages

### Models:

EHWA042A-A05	EHWA042A-F07	EHWA048A-B09	EHWA060A-A05
EHWA042A-A10	EHWA042A-F12	EHWA048A-B15	EHWA060A-A10
EHWA042A-A15	EHWA042ADA10	EHWA048A-C09	EHWA060A-A15
EHWA042A-B05	EHWA042ADC05	EHWA048A-C15	EHWA060A-B15
EHWA042A-B09	EHWA048A-A05	EHWA048A-F07	EHWA072A-A05
EHWA042A-B15	EHWA048A-A10	EHWA048A-F12	EHWA072A-A10
EHWA042A-C09	EHWA048A-A15	EHWA048ADA05	EHWA072A-A15
EHWA042A-C15	EHWA048A-B05	EHWA048ADC05	EHWA072A-B09

For Use with W\*\*AY Series  
Wall-Mounted Air Conditioners



Bard Manufacturing Company, Inc.  
Bryan, Ohio 43506  
[www.bardhvac.com](http://www.bardhvac.com)

Manual: 2100-785  
Supersedes: **NEW**  
Date: 7-11-23

# CONTENTS

---

## **General Information .....3**

Description of Equipment.....	3
Important.....	3
Shipping Damage .....	3
Unpacking Electric Heat Package.....	3
Recommended Installation Tools .....	3
Wiring Main Power.....	5

## **Installation .....7**

Installation of Heater Package .....	7
--------------------------------------	---

## **Tables**

Table 1	Electrical Data and BTU Output .....	4
Table 2	References to Figures 3 and 4 by Model Number .....	9

## **Figures**

Figure 1	Electrical Connections.....	6
Figure 2	Installation of Heater Package.....	8
Figure 3	Rod Support and Screw Mounting Positions .....	10
Figure 4	A Through D .....	11
Figure 4	E.....	12
Figure 5	Installing Heater Base and Connecting Wiring.....	13
Figure 6	Serial Plate Label.....	14

### Description of Equipment

The EHWA series electric heater packages are field-installable heater packages suitable for use with Bard wall mount air conditioners. The packages consist of the electric heat strip, the heater control base (which includes the heat contactors and circuit breaker or toggle or rotary disconnects), installation instructions and wiring diagrams. See Table 1 on page 4 for nominal electrical data and BTU output. **Before installation, check unit serial plate to ensure the heater package model to be installed is listed as a heater package that is suitable for use with the Bard wall mount** (see Figure 6 on page 14).

### Important

The equipment covered in this manual is to be installed by trained, experienced service and installation technicians.

### Shipping Damage

Upon receipt of equipment, the carton should be checked for external signs of shipping damage. If damage is found, the receiving party must contact the last carrier immediately, preferably in writing, requesting inspection by the carrier's agent.

### Unpacking Electric Heat Package

Remove the heat package from the shipping carton. The heat package must consist of the following:

- Basic heater
- Electric heat control base and wiring
- Installation instructions
- One (1) wiring diagram, to be applied to unit
- One (1) adhesive label to re-mark serial plate to indicate new model number. This is attached to the front of these instructions.
- Two (2) ladder ties to bundle the wires together

### Recommended Installation Tools

- Personal protection equipment, including gloves and safety glasses
- 5/16" nut driver
- Phillips head screwdriver
- Straight head screwdriver
- Needle nose pliers
- Multimeter

**TABLE 1**  
**Electrical Data and BTU Output**

Heater Package Model	Volts	Phase	Nominal KW	Nominal BTU
EHWA042A-A05	230/208	1	4.6/3.8	15,700/12,800
EHWA042A-A10	230/208	1	9.2/7.5	31,400/25,600
EHWA042A-A15	230/208	1	13.8/11.3	47,100/38,400
EHWA042A-B05	230/208	3	4.6/3.8	15,700/12,800
EHWA042A-B09	230/208	3	8.3/6.8	28,300/23,000
EHWA042A-B15	230/208	3	13.8/11.3	47,100/38,400
EHWA042A-C09	460	3	8.3	28,300
EHWA042A-C15	460	3	13.8	47,100
EHWA042A-F07	415/380	3	6.8/5.7	23,000/19,400
EHWA042A-F12	415/380	3	11.3/9.5	38,400/32,300
EHWA042ADA10	230/208	1	9.2/7.5	31,400/25,600
EHWA042ADC05	460	3	4.6	15,700
EHWA048A-A05	230/208	1	4.6/3.8	15,700/12,800
EHWA048A-A10	230/208	1	9.2/7.5	31,400/25,600
EHWA048A-A15	230/208	1	13.8/11.3	47,100/38,400
EHWA048A-B05	230/208	3	4.6/3.8	15,700/12,800
EHWA048A-B09	230/208	3	8.3/6.8	28,300/23,000
EHWA048A-B15	230/208	3	13.8/11.3	47,100/38,400
EHWA048A-C09	460	3	8.3	28,300
EHWA048A-C15	460	3	13.8	47,100
EHWA048A-F07	415/380	3	6.8/5.7	23,000/19,400
EHWA048A-F12	415/380	3	11.3/9.5	38,400/32,300
EHWA048ADA05	230/208	1	4.6/3.8	15,700/12,800
EHWA048ADC05	460	3	4.6	15,700
EHWA060A-A05	230/208	1	4.6/3.8	15,700/12,800
EHWA060A-A10	230/208	1	9.2/7.5	31,400/25,600
EHWA060A-A15	230/208	1	13.8/11.3	47,100/38,400
EHWA060A-B15	230/208	3	13.8/11.3	47,100/38,400
EHWA072A-A05	230/208	1	4.6/3.8	15,700/12,800
EHWA072A-A10	230/208	1	9.2/7.5	31,400/25,600
EHWA072A-A15	230/208	1	13.8/11.3	47,100/38,400
EHWA072A-B09	230/208	3	8.3/6.8	28,300/23,000

## Wiring Main Power

1. On all installations, size unit power supply wiring for the minimum circuit ampacity requirement for the unit and heater package combination listed on the unit serial plate.

For existing installations, addition or upgrading of a heater package may require that larger supply wires be run to the unit. Resize all power supply wires for the minimum circuit ampacity rating listed on the unit serial plate that is applicable for the combination of unit and heater package.

### **WARNING**

***Install properly sized power supply leads for the unit/heater combination minimum circuit ampacity as listed on the unit serial plate. Hazard of fire. Failure to install properly sized conductors could result in fire causing damage, bodily injury or death.***

2. All heater packages covered by this manual are factory wired for a single supply circuit. The following heater packages are field convertible to a dual supply circuit if required or desired.

EHWA042A-A15  
EHWA048A-A15  
EHWA060A-A15  
EHWA072A-A10  
EHWA072A-A15

3. To convert the above heater packages to dual circuit configuration before installation, loosen four (4) screws holding jumper bar in place and remove jumper bar. Circuit A + B are now identified on the heater package (see Figure 1 on page 6).

Wire should be sized to the minimum circuit ampacity as specified on the serial plates of units that accept these heater packages for circuits A + B.

**FIGURE 1**  
**Electrical Connections**

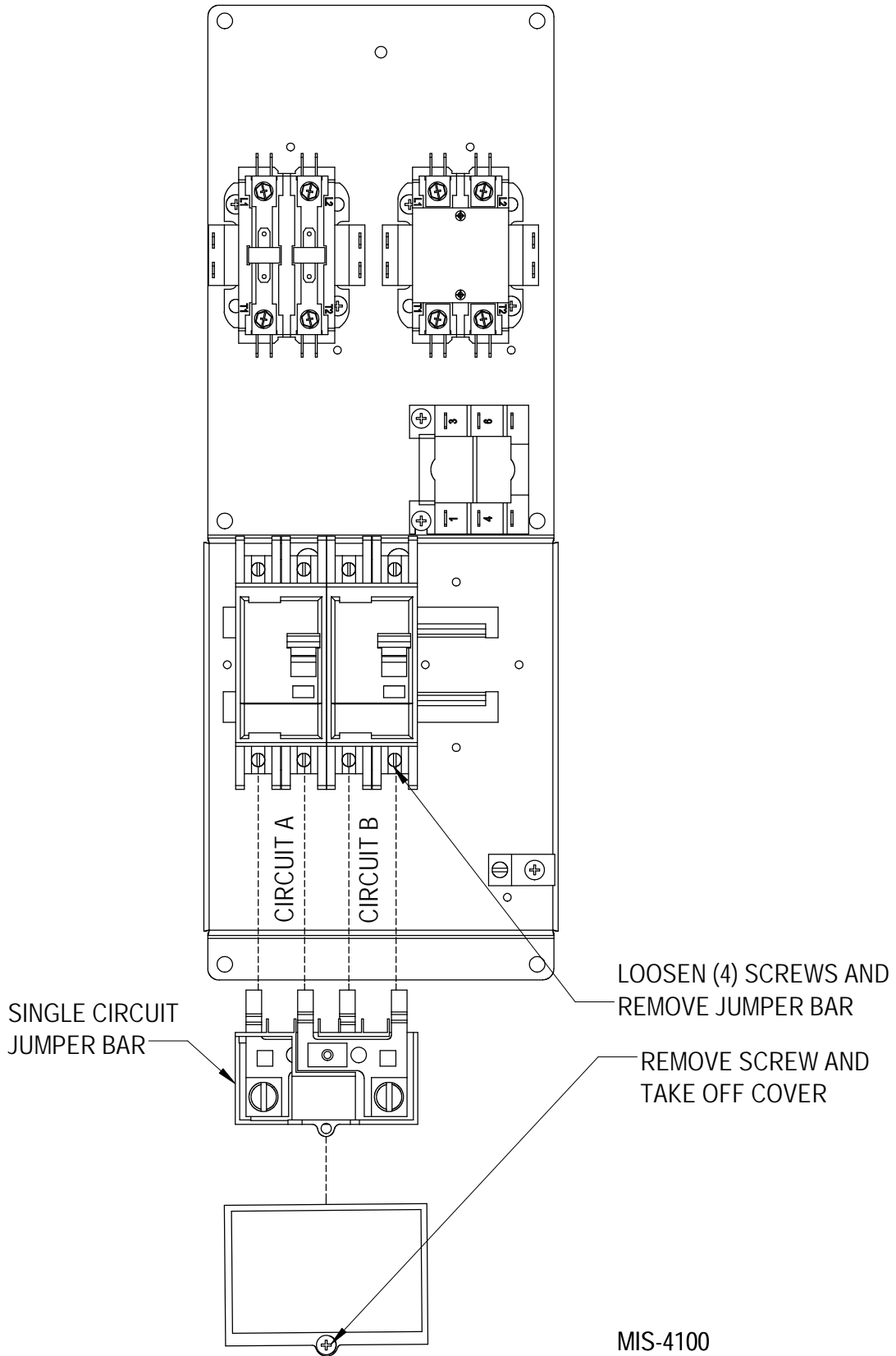

## Installation of Heater Package

1. Disconnect all power to unit before installation.

### **WARNING**

***Disconnect all power to unit before installing heater package. Hazard of electrical shock. Failure to disconnect power could result in injury or death.***

2. Before installation, check unit serial plate to ensure that the heater package model to be installed is listed as a heater package suitable for use with the unit.

Under no circumstances shall a heater package be installed in a unit if the model number of the heater package does not appear on the unit serial plate.

### **WARNING**

***Install only heater packages listed on unit serial plate. Hazard of fire or electrical shock. Failure to install listed heater package could result in fire, injury or death.***

3. Remove electric heater access panel, side access cover and control panel covers, both inner and outer (see Figure 2 on page 8).
4. All heaters are installed with the thermal cutoffs positioned to the top of the unit. Install heat strip(s) through heater access opening. Position heat strip support rod in heater support hole 1, 2 or 3 as indicated in Table 2 on page 9 and Figure 3 on page 10. Secure in place with two (2) sheet metal screws in mounting holes. On heater packages with two heat strips, install 9KW or 10KW heater first in position closest to the outlet air frame (see Figures 4D on page 11 and 4E on page 12).

5. Install heater control base into top of control panel as shown in Figure 5 on page 13. Secure with four (4) sheet metal screws provided.
6. Plug male 3-pin connector into mating connector mounted in control panel (see Figure 5).
7. Connect red compressor supply lead to L1 of terminal block. Connect black compressor supply lead to L2 of terminal block. If 3 phase, connect yellow supply lead to L3 of terminal block. See Figure 5 and wiring diagram.
8. Route wires from heater control base around the back side of the drain hose and up to the heater package through the bushing. Use the included ladder ties evenly spaced apart to bundle the wires together (see Figure 5).
9. Wire heater package per wiring diagram supplied with this heater package. All wires are stamped with wire numbers that correspond with terminal numbers on the wiring diagram and stamped numbers on the heat strip. Limit switch wires are terminated with insulated quick connect terminals. See appropriate Figure 4 on page 11 or 12.
10. Attach adhesive wiring diagram directly above unit wiring diagram on inner control panel cover.
11. Recheck all wiring. Break out appropriate circuit breaker tabs on inner control panel cover to allow trip lever to protrude. Replace control panel and heater access panels
12. Resupply power to the unit and check for proper operation.
13. Re-mark serial plate with self-adhesive label attached to the front of this manual (see Figure 6 on page 14).

**FIGURE 2**  
**Installation of Heater Package**

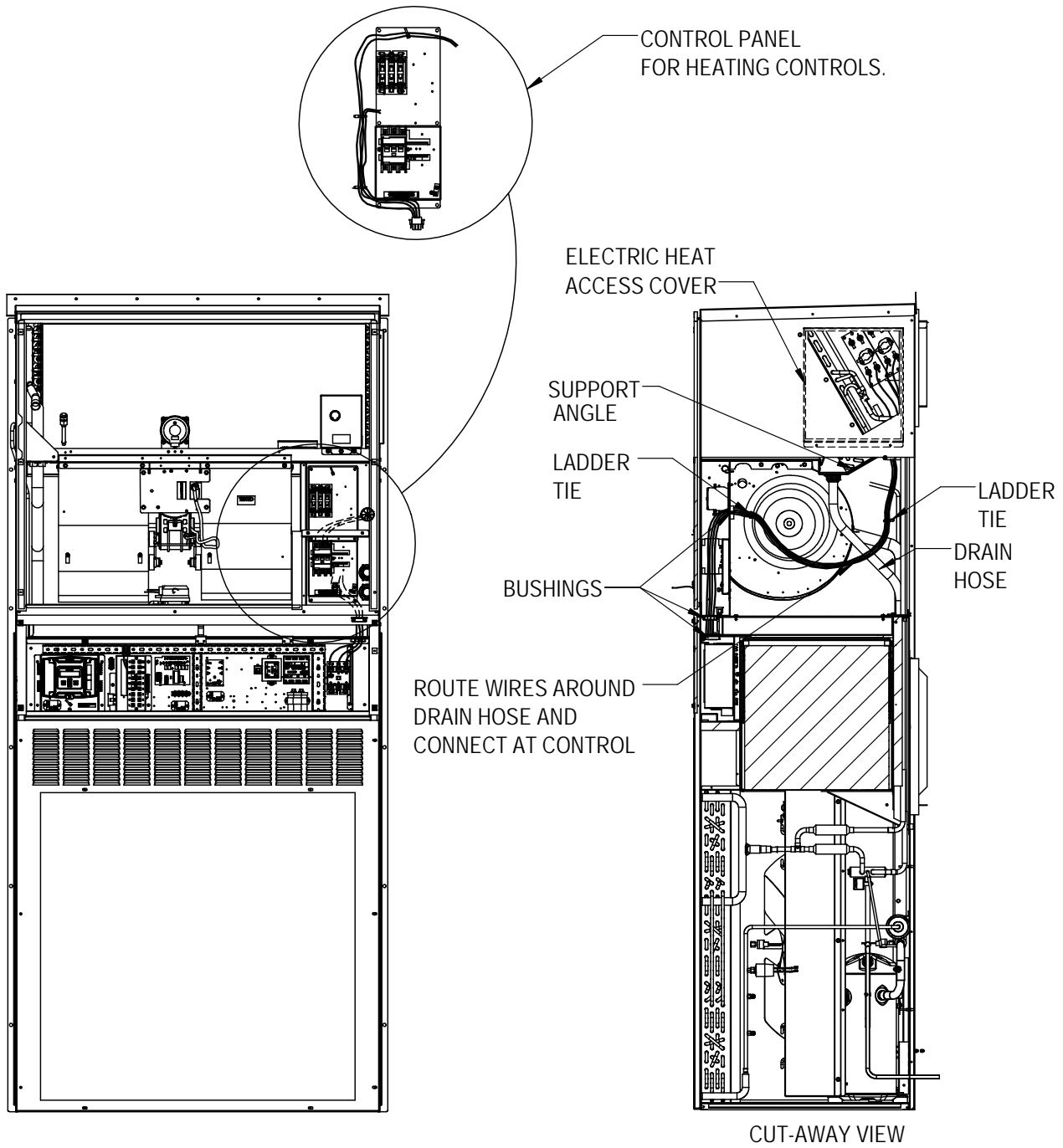

MIS-4099 A



**TABLE 2**  
**References to Figures 3 and 4 by Model Number**

Heater Package Model Number	Figure 3 Rod Support and Screw Mounting Position	Figure 4 Heater Terminal Identification Drawing
EHWA042A-A05	1	4A
EHWA042A-A10	1	4C
EHWA042A-A15	1 + 3	4D
EHWA042A-B05	1	4B
EHWA042A-B09	1	4B
EHWA042A-B15	1 + 3	4E
EHWA042A-C09	1	4B
EHWA042A-C15	1 + 3	4E
EHWA042A-F07	1	4B
EHWA042A-F12	1 + 3	4E
EHWA042ADA10	1	4C
EHWA042ADC05	1	4B
EHWA048A-A05	1	4A
EHWA048A-A10	1	4C
EHWA048A-A15	1 + 3	4D
EHWA048A-B05	1	4B
EHWA048A-B09	1	4B
EHWA048A-B15	1 + 3	4E
EHWA048A-C09	1	4B
EHWA048A-C15	1 + 3	4E
EHWA048A-F07	1	4B
EHWA048A-F12	1 + 3	4E
EHWA048ADA05	1	4A
EHWA048ADC05	1	4B
EHWA060A-A05	1	4A
EHWA060A-A10	1	4C
EHWA060A-A15	1 + 3	4D
EHWA060A-B15	1 + 3	4E
EHWA072A-A05	1	4A
EHWA072A-A10	1	4C
EHWA072A-A15	1 + 3	4D
EHWA072A-B09	1	4B

**FIGURE 3**  
**Rod Support and Screw Mounting Positions**

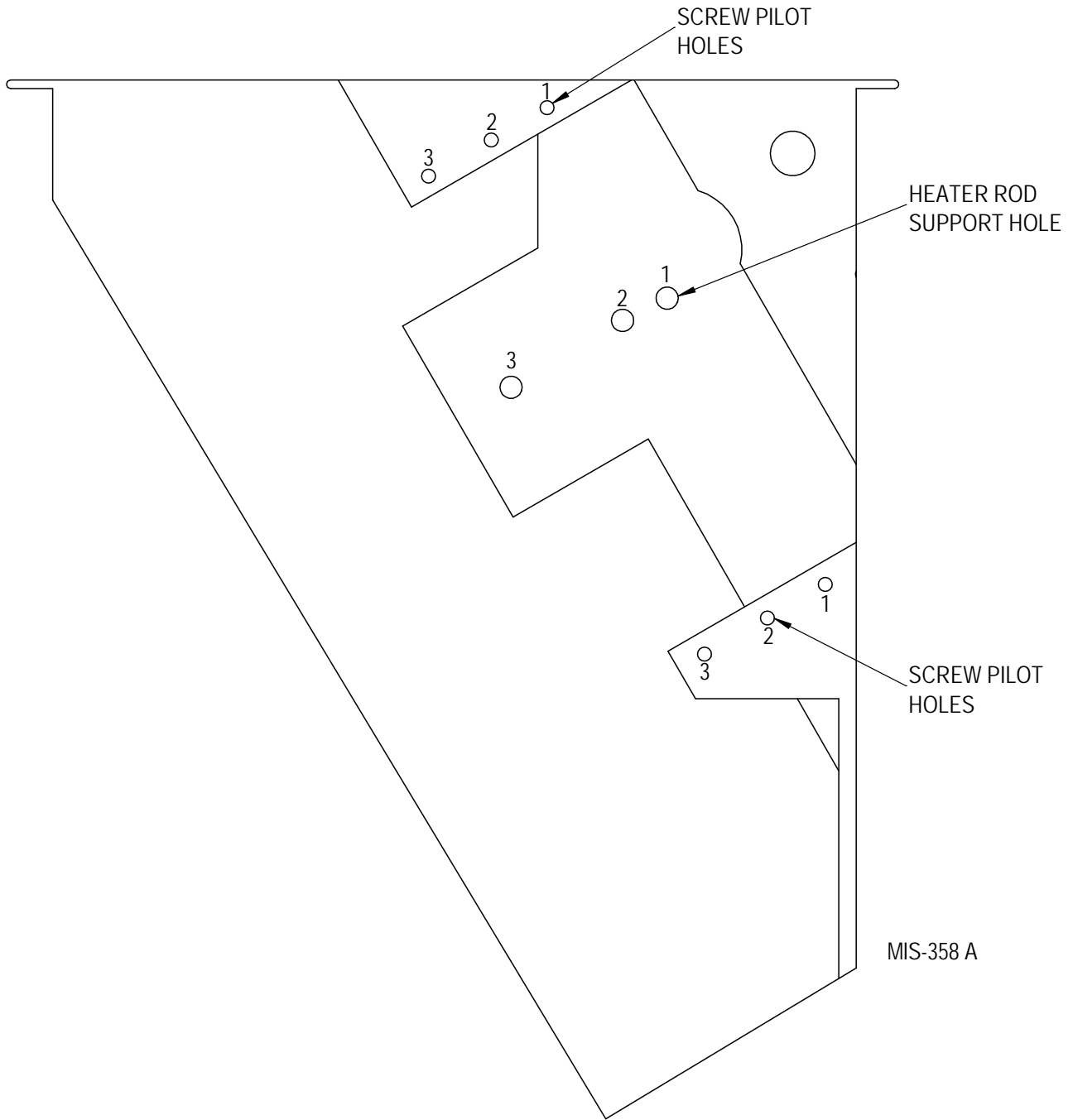

**FIGURE 4  
A Through D**

FIGURE 4A

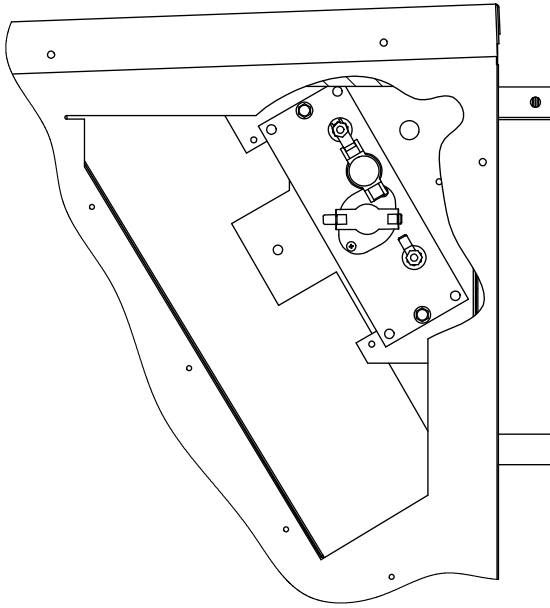

FIGURE 4B

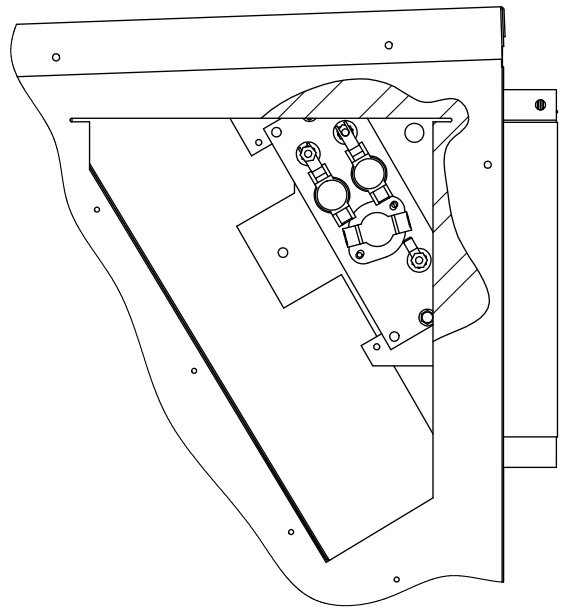

FIGURE 4C

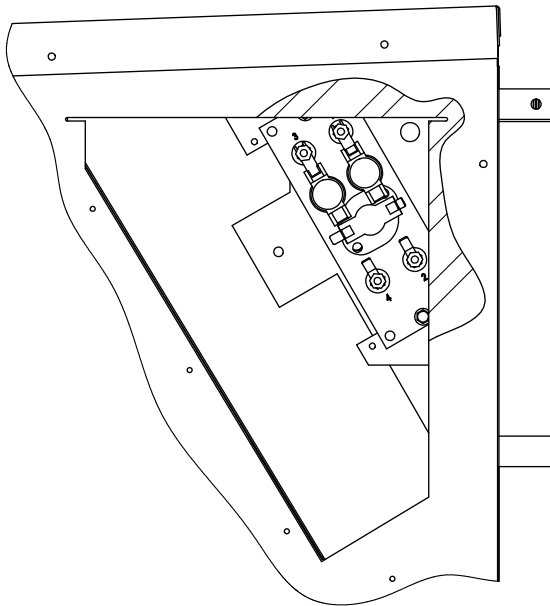
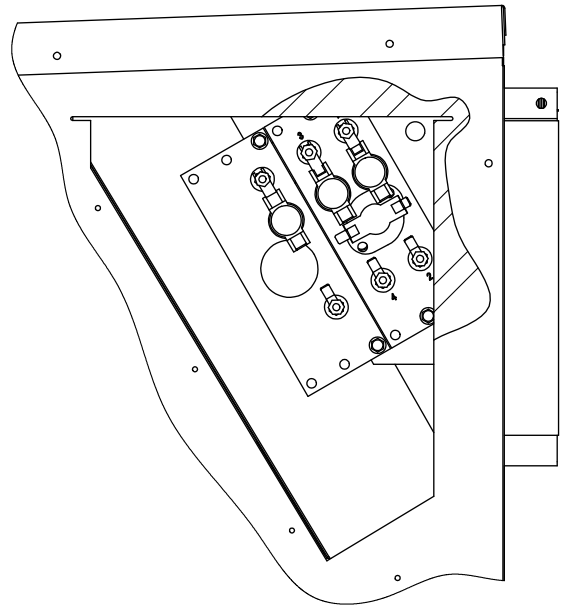
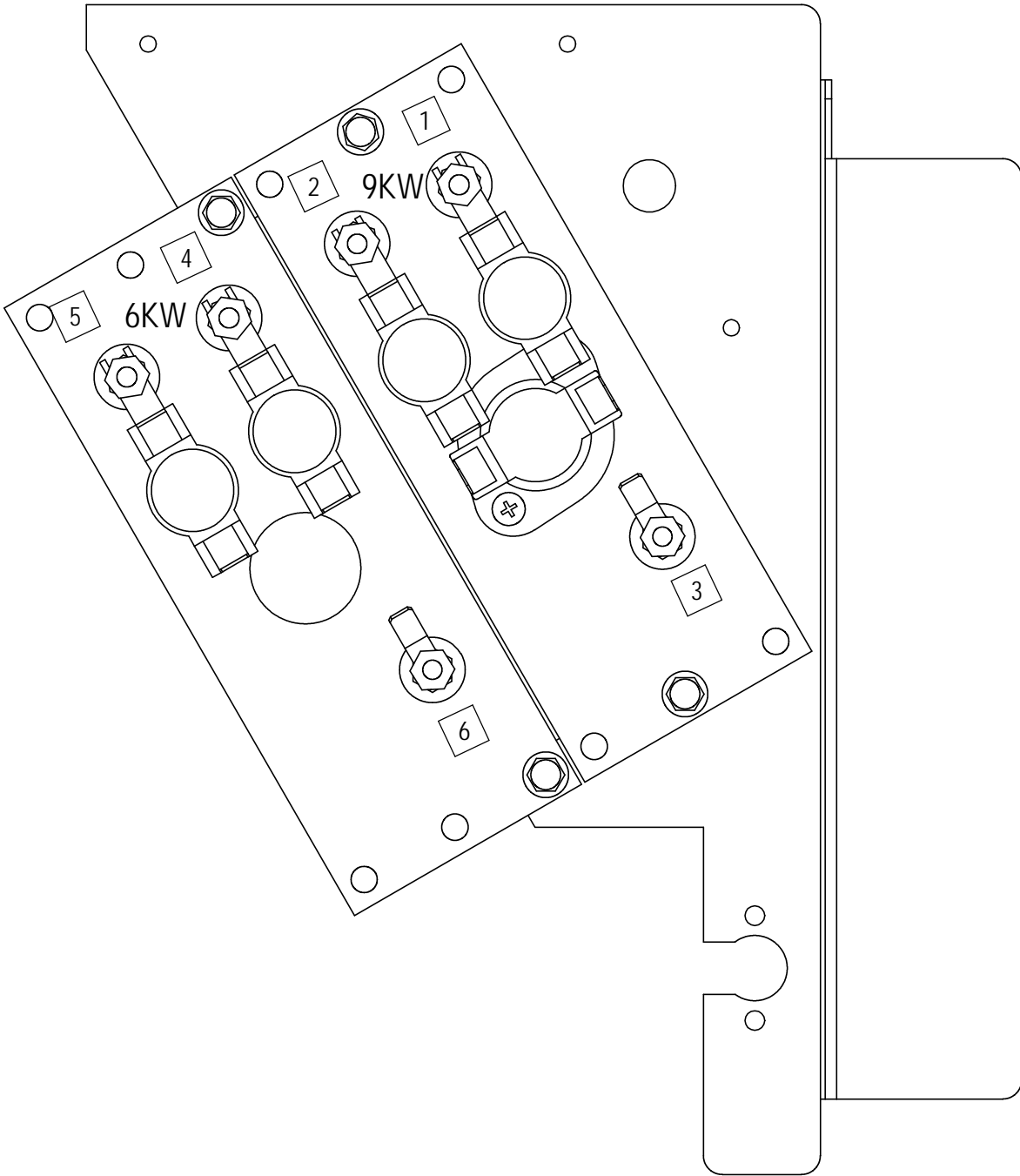

FIGURE 4D



MIS-4422 A

FIGURE 4E



MIS-4451

**FIGURE 5**  
**Installing Heater Base and Connecting Wiring**

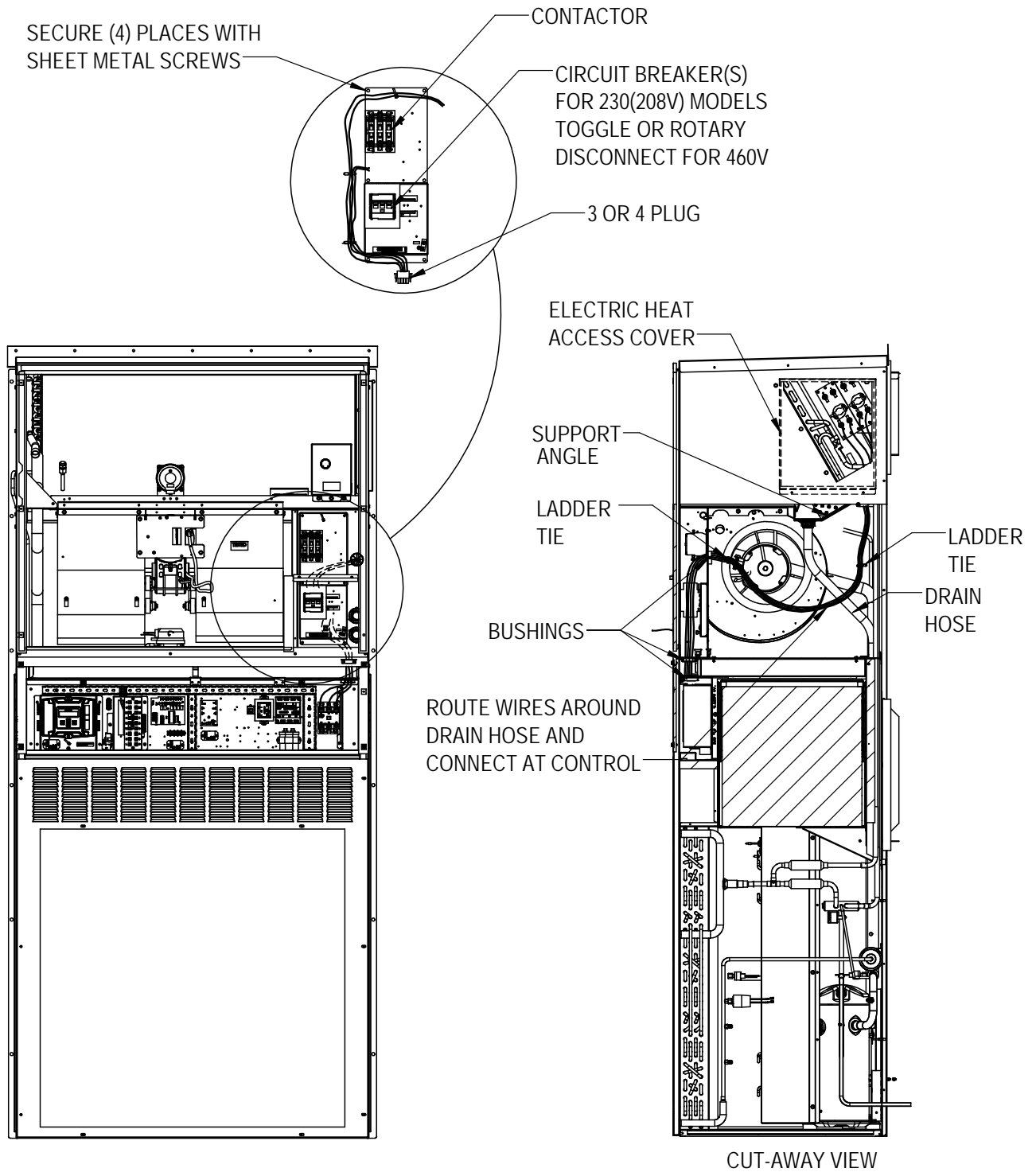

MIS-4468

**FIGURE 6  
Serial Plate Label**

INSTALL ONLY HEATER PACKAGES LISTED HERE

BARD MANUFACTURING CO. INC., 1914 RANDOLPH DRIVE

(1)  
APPROVED  
HEATER

MODEL	PACKAGE	VAC~	HZ	PH
( ) C36HY-A00	NONE	230/208	60	1
( ) C36HY-A0Z	WMCBC-04A	230/208	60	1
(X) C36HY-A05	EHCH036A-A05	230/208	60	1
( ) C36HY-A10	EHCH036A-A10	230/208	60	1
( ) C36HY-A15	EHCH036A-A15	230/208	60	1

SHORT-CIRCUIT CUR  
BRANCH CIRCUIT SELECT CURRENT 14.1A OPER

SERIAL NUMBER      XXXXXXXXXXXXXXXX-XX

SUITABLE FOR PARTIAL OUTDOOR EXPOSURE IN THROUGH THE WALL  
ALL MOTORS ARE THERMALLY PROTECTED

	VAC	HZ	PH	HP	FL
COMPRESSOR	230/208	60	1		
OUTDOOR MOTOR	230/208	60	1	1/3	1.9
INDOOR MOTOR	230/208	60	1	1/2	1.4
ERV	230/208	60	1		2.2 (C
HEATER PACKAGE				KW	FLA
EHCH036A-A05	230/208	60	1	4.6/3.8	20.0/14
EHCH036A-A10	230/208	60	1	9.2/7.5	40.0/3
EHCH036A-A15	230/208	60	1	13.8/11.3	60.0/5

ASSURE THAT SERIAL PLATE IS CLEAN AND DRY, REMOVE APPROPRIATE LABEL STRIP FOR KW REQUIRED AND REMARK SERIAL PLATE AS SHOWN FOR THE HEATER PACKAGE THAT IS INSTALLED

MIS-384 A