

---

# INSTALLATION INSTRUCTIONS

---

## Partial Flow Modulating Commercial Room Ventilator with Pre-Purge and Exhaust

Models:  
CRV-V2 CRV-V3

For Use with Bard Wall Mount  
Air Conditioner and Heat Pump Models:

CRV-V2: W18A/LY, W24A/LY, W18HY, W24HY  
CRV-V3: W30A/LY, W36A/LY, W30HY, W36HY




Bard Manufacturing Company, Inc.  
Bryan, Ohio 43506  
[www.bardhvac.com](http://www.bardhvac.com)

Manual: 2100-793  
Supersedes: **NEW**  
Date: 7-13-23

# CONTENTS

<b>General Information .....</b>	<b>3</b>
Commercial Room Ventilator Model Nomenclature ...	3
Unpacking .....	3
Field-Supplied Tools Needed .....	3
General .....	3
Description .....	3
Models .....	3
<b>Installation of Field-Installed CRV-V* .....</b>	<b>4</b>
Basic Installation.....	4
Preparing Unit for CRV-V Installation .....	4
Commercial Room Ventilator (CRV) No Hood Installation .....	7
CO <sub>2</sub> Control.....	9
Control System Notes.....	9
Two Switch Application .....	9
Blade Adjustment for Desired Ventilation Air .....	18
"V" Option CRV Sequence of Operation .....	21
Pre-Purge Feature.....	21
Occupied Setting.....	22
Y1 Setting .....	22
Y2 Setting .....	22
2-10V Operation.....	22



## WARNING

***Exposed moving parts.***

***Disconnect all electrical power before servicing.***

***Failure to do so can result in severe injury or amputation.***



## CAUTION

***Sharp metallic edges.***

***Take care and wear appropriate protective devices to avoid accidental contact with sharp edges.***

***Failure to do so can result in personal injury.***

## Figures

Figure 1 Wall-Mount Unit Access Panels .....	4
Figure 2 Condenser Exhaust Plate with Screen.....	5
Figure 3 CRV and Return Fill Installation with Filter Partition and Tray Assembly.....	6
Figure 4 Extension Cable Installation .....	7
Figure 5 Damper Assembly Installation .....	8
Figure 6 Vent Door Assembly.....	9
Figure 7 CRV Control Board Settings.....	10
Figure 8 CRV Control Board Wiring .....	11
Figure 9 Actuator Setting.....	12
Figure 10 Programmable Thermostat Connections for CRV-V* with Air Conditioners.....	13
Figure 11 Programmable Thermostat Connections for CRV-V* with Heat Pumps .....	14
Figure 12 Non-Programmable Thermostat Connections for CRV-V* with Air Conditioners .....	15
Figure 13 Non-Programmable Thermostat Connections for CRV-V* with Heat Pumps .....	16
Figure 14 CO <sub>2</sub> Sensor Default and Final Settings Bard Part #8403-096 CO <sub>2</sub> Controller ....	17
Figure 15 CRV Control Board .....	21
Figure 16 Call for Ventilation With or Without Compressor Operation.....	23
Figure 17 Call for Compressor or Fan Only with Ventilation Off .....	24

## Graphs

Graph 1 W18 Ventilation Delivery.....	19
Graph 2 W24 Ventilation Delivery.....	19
Graph 3 W30 Ventilation Delivery.....	20
Graph 4 W36 Ventilation Delivery.....	20

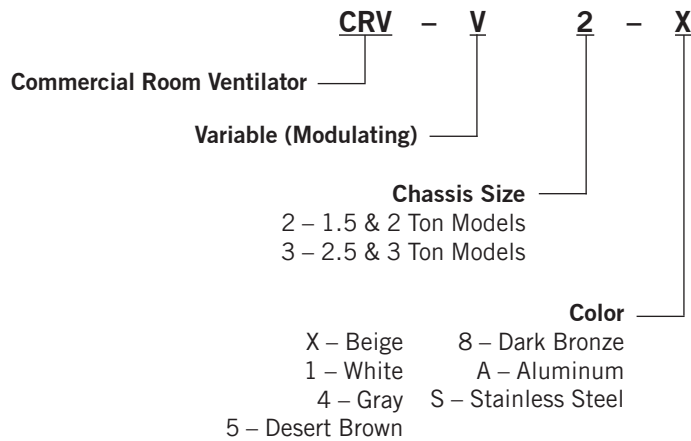
## Table

Table 1 Unit Operation with V (Variable CRV) Ventilation Option.....	22
--	----

## Commercial Room Ventilator Features

- One piece construction – easy to install with no mechanical linkage adjustment required.
- Exhaust air damper – built in with positive closed position. Provides exhaust air capability to prevent pressurization of tight buildings.
- Actuator motor – 24 volt, power open, spring return with built in torque limiting switch.

## Commercial Room Ventilator Model Nomenclature



### Unpacking

Upon receipt of the equipment be sure to compare the model number found on the shipping label with the accessory identification information on the ordering and shipping document to verify that the correct accessory has been shipped.

Inspect the carton housing of each ventilator as it is received, and before signing the freight bill, verify that all items have been received and that there is no visible damage. Note any shortages or damage on all copies of the freight bill. The receiving party must contact the last carrier immediately, preferably in writing, requesting inspection by the carrier's agent. Concealed damage not discovered until after loading must be reported to the carrier within 15 days of its receipt.

### Field-Supplied Tools Needed

- Appropriate personal protection equipment, including gloves and safety glasses
- 5/16" nut driver
- Phillips head screwdriver
- Small flat head screwdriver for securing wire in terminal blocks
- Electrical tools
- Multimeter

### General

The ventilator should only be installed by a trained heating and air conditioning technician. These instructions serve as a guide to the technician installing the ventilator package. They are not intended as a step-by-step procedure with which the mechanically inclined owner can install the package.

The ventilator housing is shipped in one carton which contains the electrical harness, miscellaneous hardware and installation instructions.

### Description

The CRV-V ventilator is designed to be used with the specific models with "letter" revision codes as designated on the front page of this installation instructions manual.

The built-in commercial room ventilator with modulating blade position is internally mounted behind the service door and allows outside ventilation air, up to 50% of the total airflow rating of the unit. It includes a built-in exhaust air damper for room pressurization relief. Blade seals allow for minimal blade leakage. A ventilation control board allows multiple blade settings to adjust intake airflow. By setting multiple blade positions, pre-purge, occupied, and unoccupied airflow amounts are possible with capable thermostats and controllers. The CRV-V also allows for 0-10V or 4-20ma input for modulating ventilation control based on CO<sub>2</sub> levels. Complies with ANSI/ASHRAE Standard 62.1 "Ventilation for Acceptable Indoor Air Quality" and other state and local ventilation codes that require outdoor air intake but not economizer operation.

### Models

When installed in the models listed on the front page, the CRV-V provides built-in exhaust provisions. When the damper blade opens to bring fresh air in, the damper also opens an exhaust relief. The exhaust air will flow into the condenser section of the unit. The condenser fan will help draw exhaust air out when it is operating with compressor in cooling or heat pump mode.

# INSTALLATION OF FIELD-INSTALLED CRV-V\*

## Basic Installation

### WARNING

**Electrical shock hazard.**

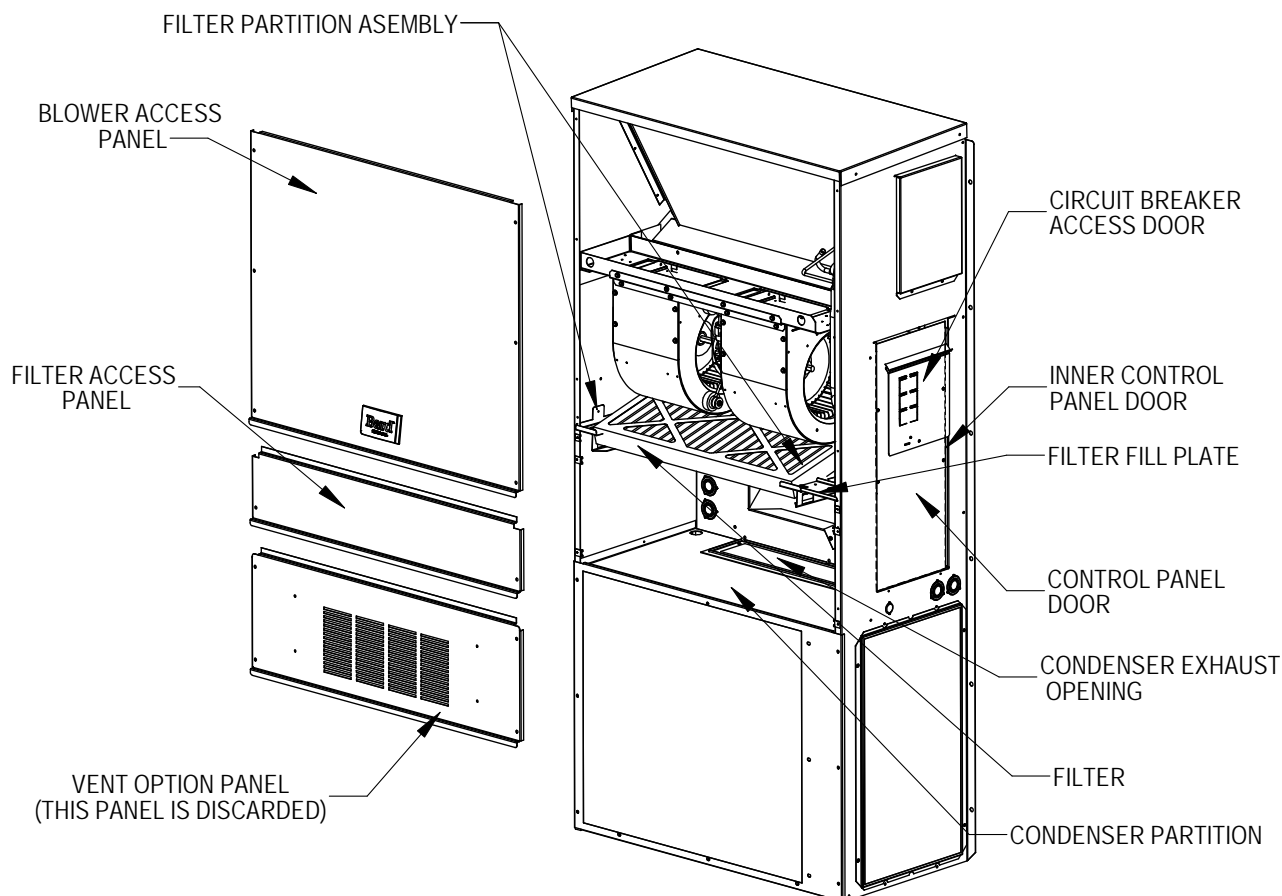
**Disconnect remote electrical power supply or supplies before servicing.**

**Failure to do so could result in electric shock or death.**

## Preparing Unit for CRV-V Installation

1. Disconnect power to unit.
2. Unpack the CRV-V assembly, which includes the integral controls and electrical harness, body panels, miscellaneous hardware and installation instructions.
3. From existing wall mount unit, remove and save (or discard) as directed (see Figure 1):
  - Blower access panel (save)
  - Vent option panel (discard)
  - Filter access panel (save)
  - Filter (save)
  - Outer and inner control panel doors (save)
  - Exhaust cover plate (discard)
4. Install new condenser exhaust plate with screen over opening into condenser section using four (4) 1012-086 screws supplied in the parts bag included (see Figure 2).
5. The unit includes a filter partition and tray assembly installed below the blower. The ventilator can be installed without moving this assembly, but it may be beneficial to loosen the front two (2) mounting screws of the filter partition assembly. The assembly

**FIGURE 1**  
**Wall-Mount Unit Access Panels**

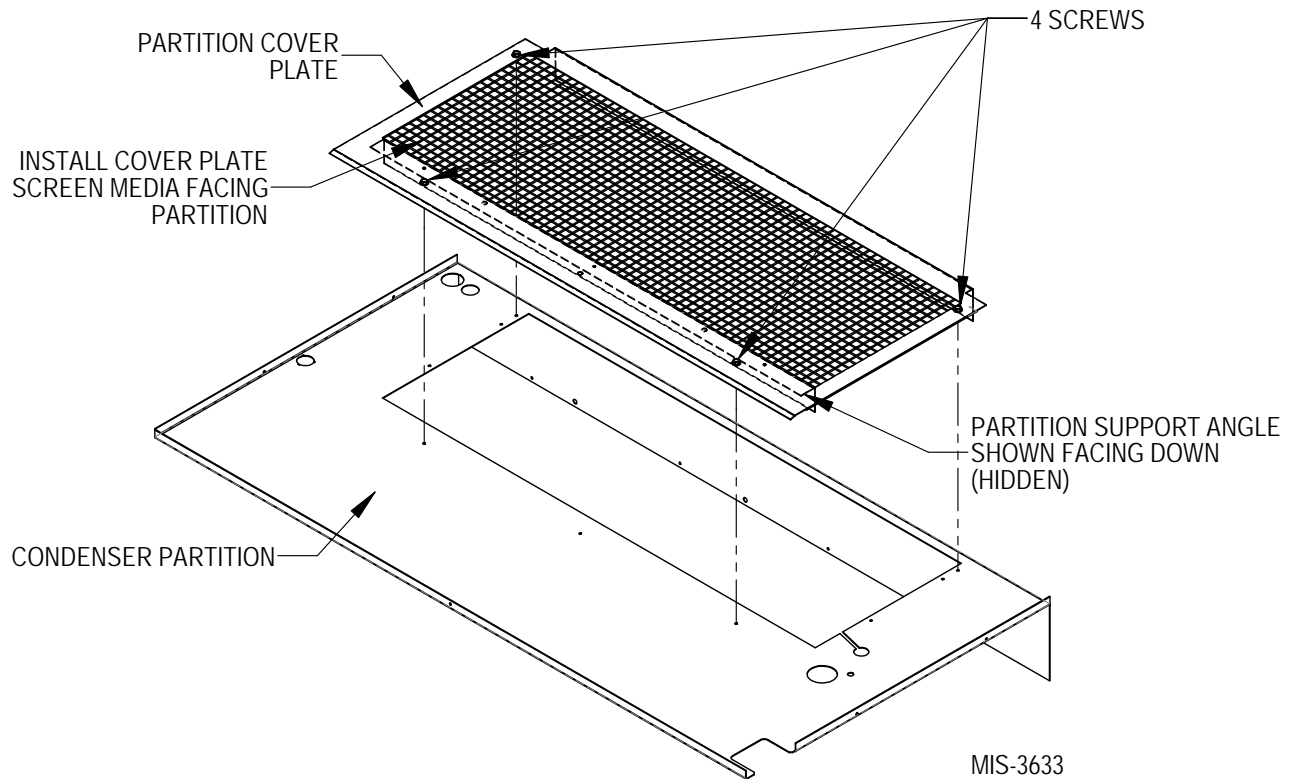


MIS-4452 A

can then be lifted up slightly to allow more room for installation of the unit ventilator.

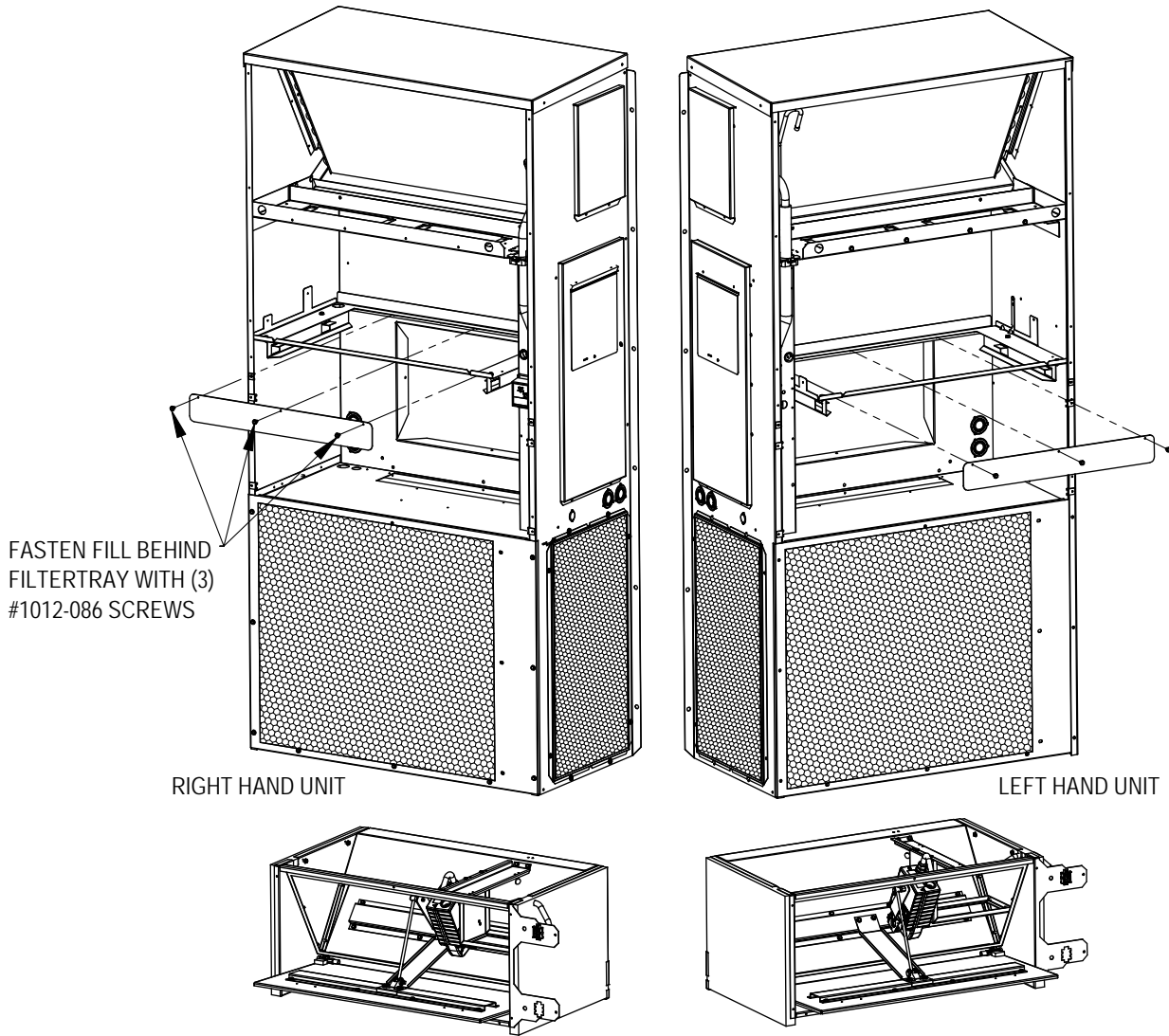
Install the return fill plate using three (3) 1012-086 screws included in parts bag as shown in Figure 3 on page 6.

**FIGURE 2**  
**Condenser Exhaust Plate with Screen**



**FIGURE 3**  
**CRV and Return Fill Installation with Filter Partition and Tray Assembly**

**NOTE:** The return fill plate will need to be installed before the CRV assembly (see below).

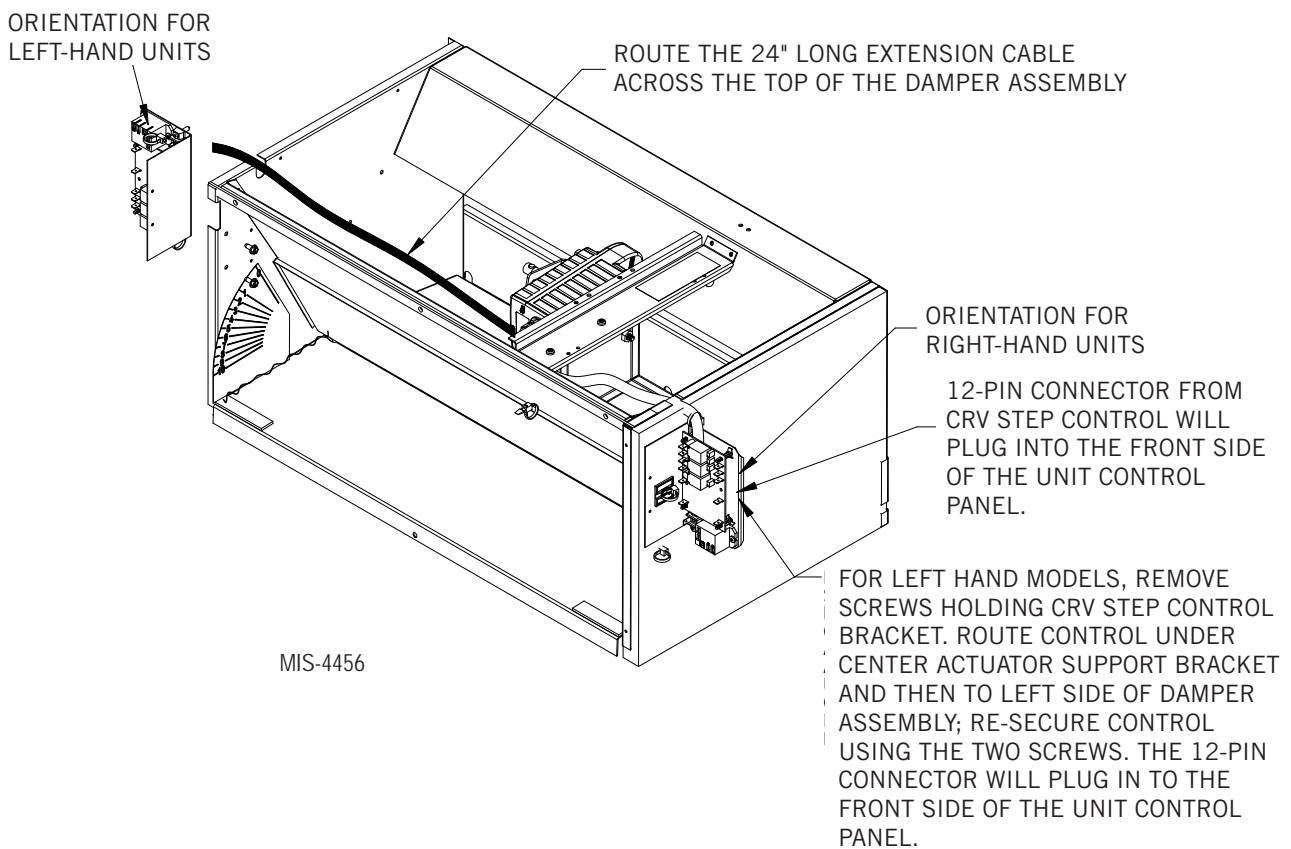


MIS-4205

### Commercial Room Ventilator (CRV) No Hood Installation

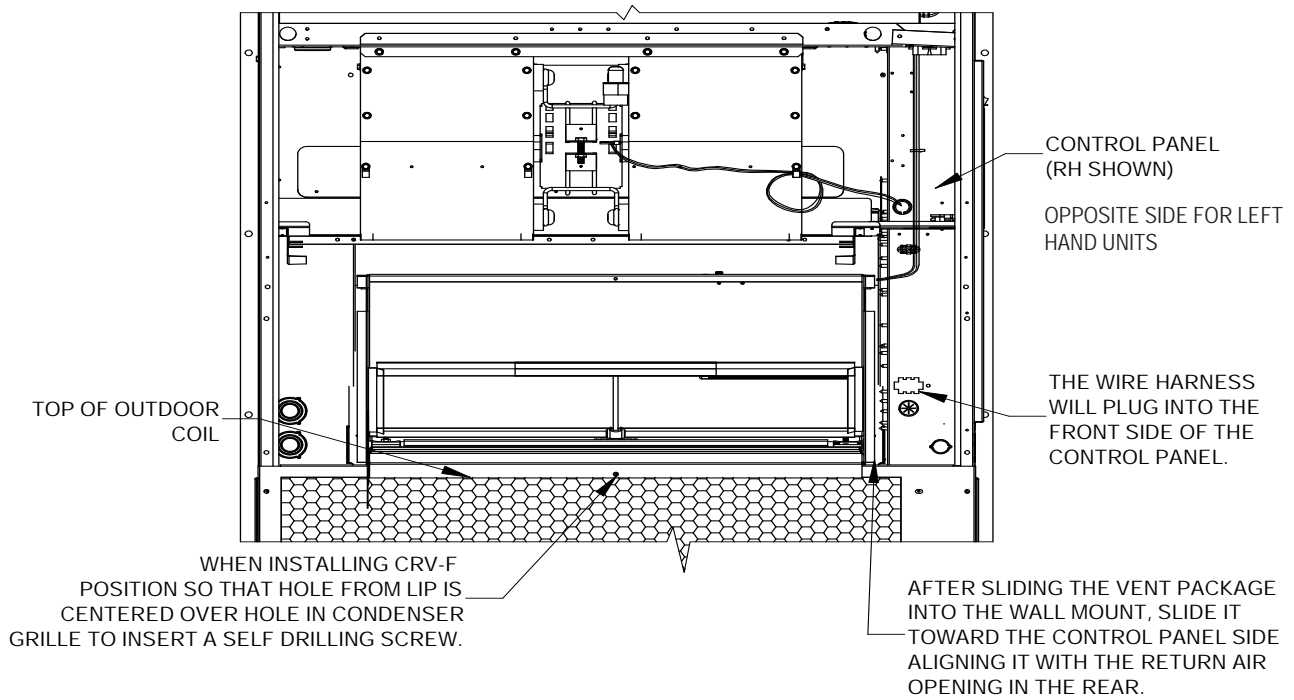
1. Insert CRV into opening in the wall mount unit between the filter rack and the condenser section, being careful not to tear the unit insulation. Fully seat CRV assembly to rear of the cavity. Slide the CRV toward the control panel so that it lines up with the return air opening in the rear of the wall mount unit (see Figure 5 on page 8). For installation in left control panel units, see Figure 4.
2. Insert and lock in the 12-pin plug end of the wire assembly into the front side of the unit's control panel (see Figure 5).
3. Re-install and tighten front filter tray mounting screws (if loosened in Step 5 on page 4).
4. Replace the air filter if it was removed (airflow direction is up).
5. The next step involves installing the unit's filter door and putting the mist eliminator filter into place (see Figure 6 on page 9).
6. With the lower vent option door removed, locate the control board. Then, make all the required thermostat connections per the applicable connection diagram found on pages 13 – 16, and restore power to the unit.
7. Make any necessary changes required to the potentiometers to achieve the minimum continuous airflow and total airflow desired (see Figure 7 on page 10). Refer to **Blade Adjustment for Desired Ventilation Air** on page 18 for more information on adjusting the potentiometers.
8. Replace the vent option panel with the door that is provided in the CRV kit. Attach using the four (4) provided screws as shown in Figure 6.

**FIGURE 4**  
**Extension Cable Installation**



**NOTE:** Incorporated with the CRV-V is one piece of split tubing. The tubing will cover the wire assembly routed to the actuator. The tubing and wires will be routed under the actuator assembly.

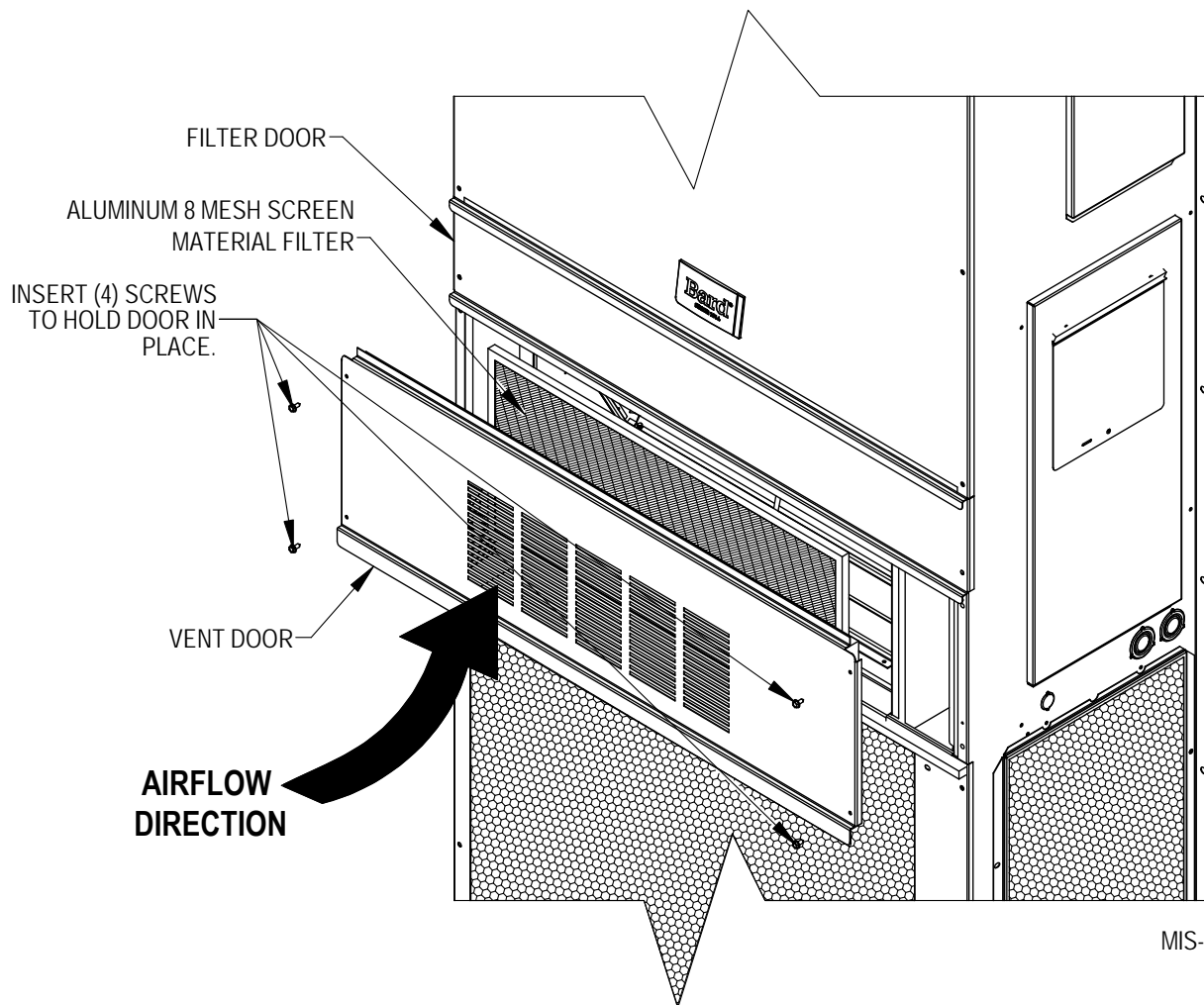
**FIGURE 5**  
**Damper Assembly Installation**



MIS-4364



**FIGURE 6**  
**Vent Door Assembly**



### **CO<sub>2</sub> Control**

For CO<sub>2</sub>-based control, order CO<sub>2</sub> sensor/controller separately (Bard part #8403-096) and add to the wall and run additional optional wires as shown in the wiring diagrams on pages 13 – 16.

The CO<sub>2</sub> controller must also be reconfigured from the standard default settings as shipped from the factory. See page 17 for complete details.

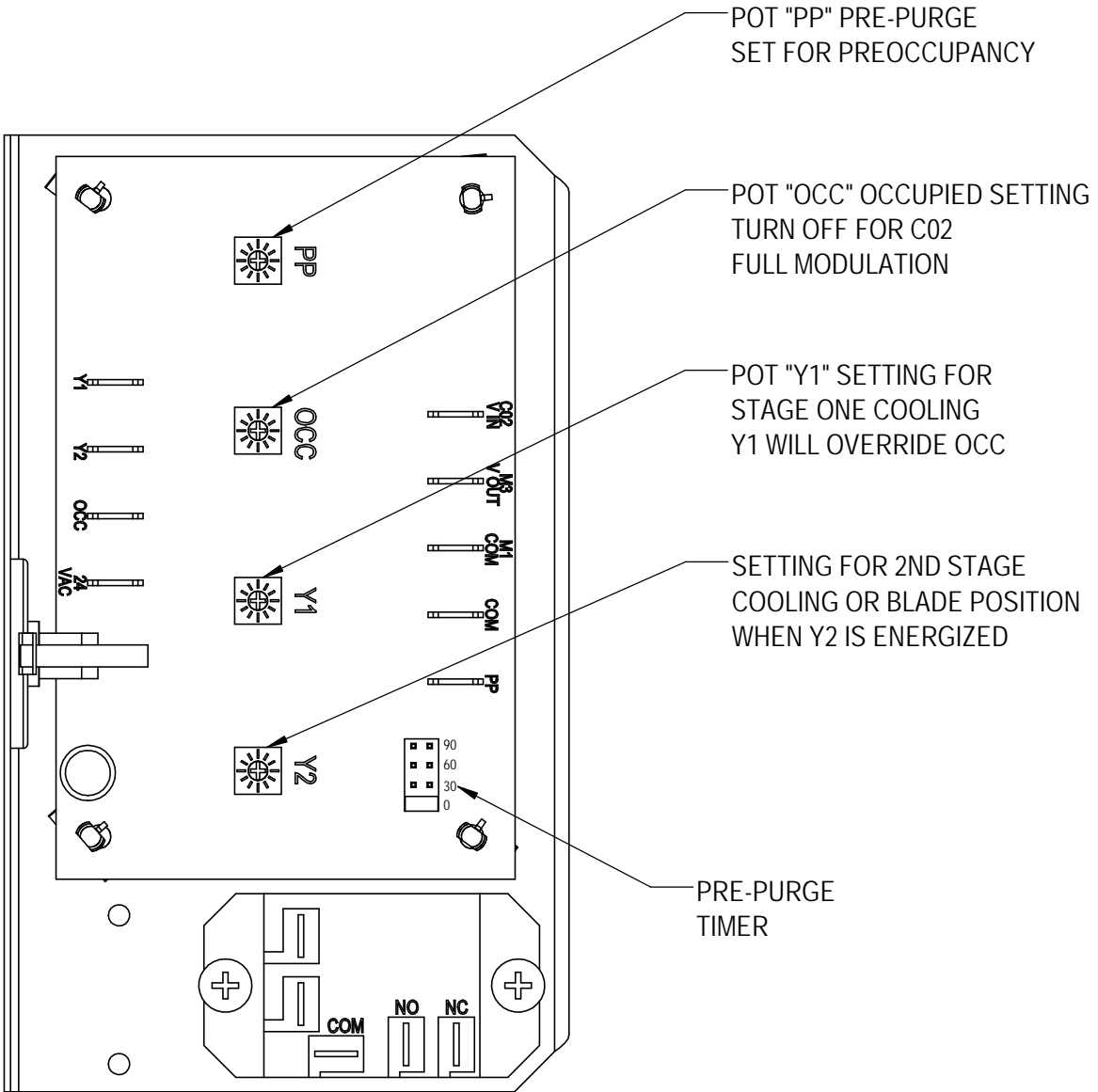
### **Control System Notes**

This ventilation package is capable of being set to meet the current ASHRAE specifications for minimum occupied airflow rates, with extended capability to meet demand ventilation requirements.

#### **Two Switch Application**

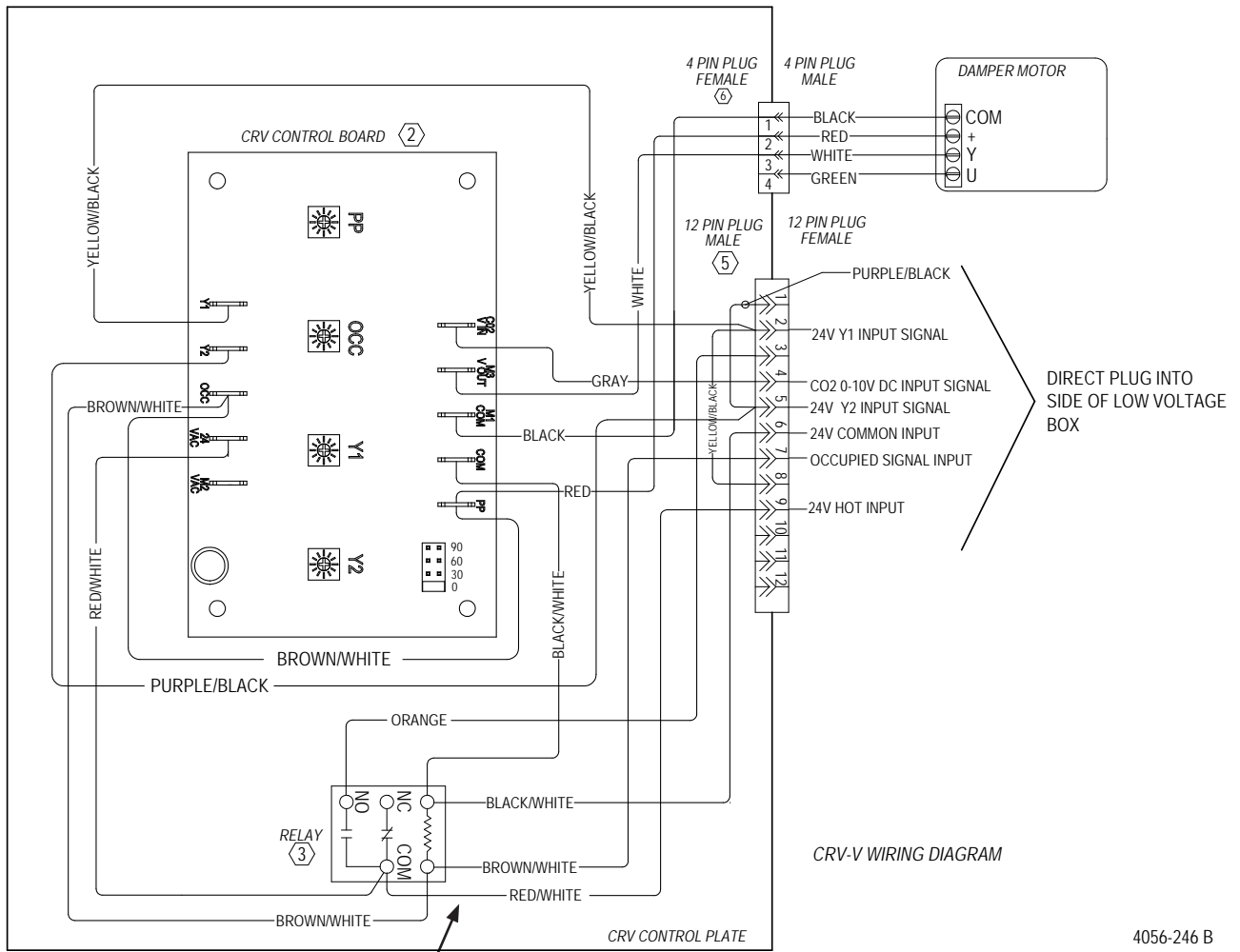
Energizing the A terminal in the low voltage connection box during occupied conditions will allow the prepurge and minimum occupied airflow rates to be set to meet ASHRAE requirements. This can be accomplished by adjusting the PP and OCC potentiometers on the CRV control board (see Figure 7 on page 10) by aligning the damper position per the charts included on pages 19 and 20.

**FIGURE 7**  
**CRV Control Board Settings**



MIS-4047

**FIGURE 8**  
**CRV Control Board Wiring**



CRV-V WIRING DIAGRAM

4056-246 B

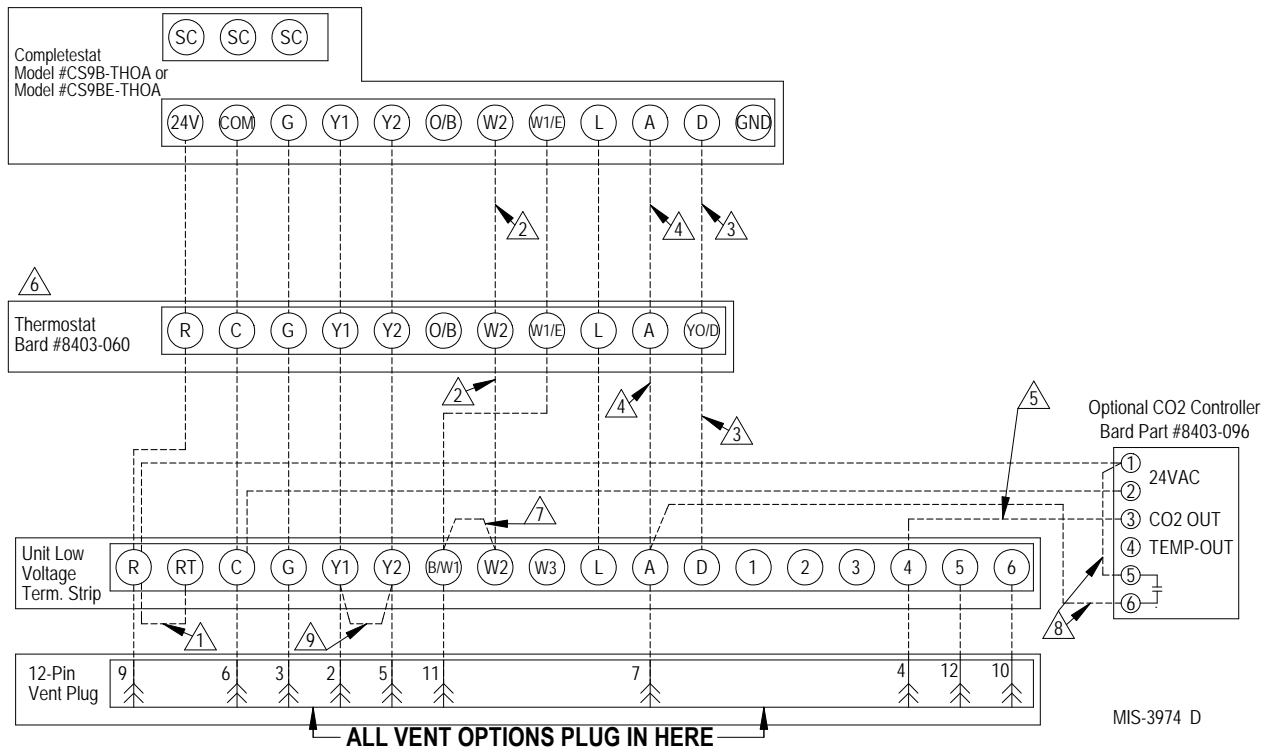
Move this RED/WHITE wire from COM to NC if jumper is used between A and G. See page 15 or 16 for additional information.

**FIGURE 9**  
**Actuator Setting**

*NOTE: For proper operation, dial must be set to CCW as shown.*



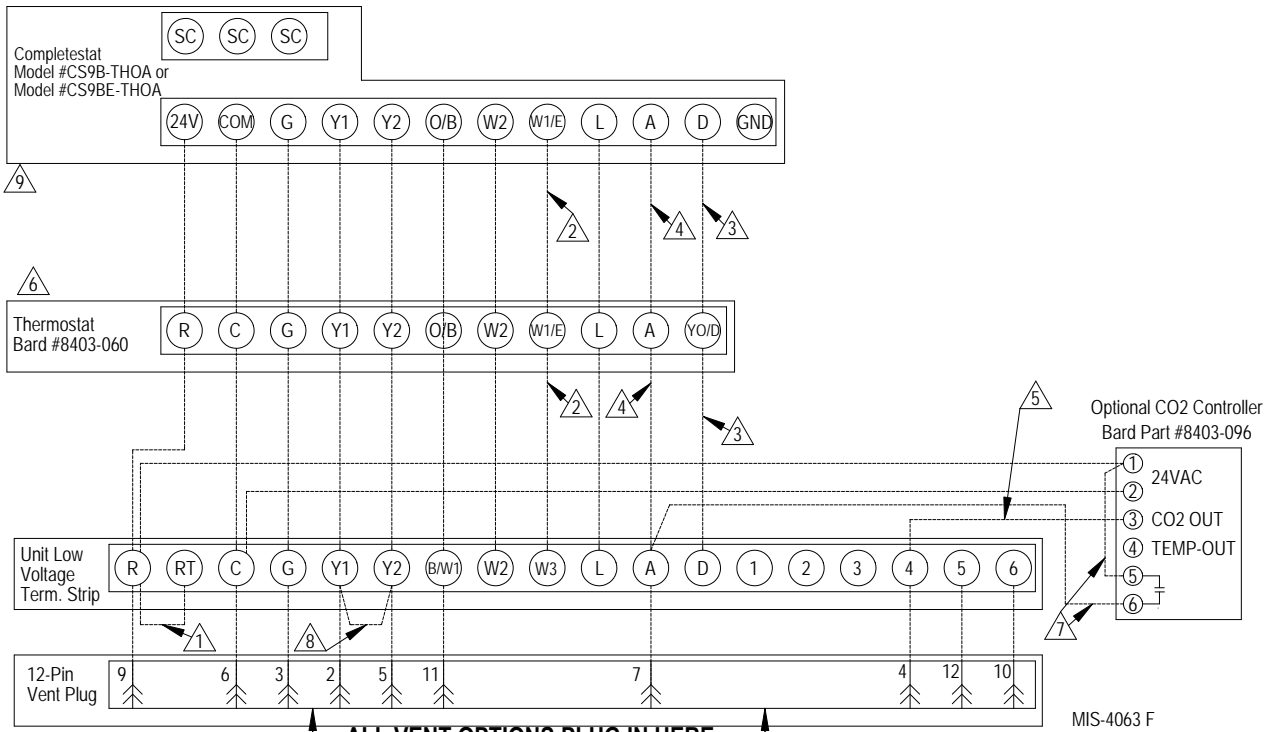
**FIGURE 10**  
**Programmable Thermostat Connections for CRV-V\* with Air Conditioners**



*If not equipped with a ventilation option to plug in, a jumper plug must be installed.*

- |   |   |
|---|---|
| <p>▲1 Factory installed jumper. Remove jumper and connect to N.C fire alarm circuit if emergency shutdown required.</p> <p>▲2 Wire not needed below 15KW.</p> <p>▲3 Wire required for dehumidification models only.</p> <p>▲4 Do not connect "A" from thermostat if optional CO2 controller is used</p> <p>▲5 0-10 VDC modulating CO2 control signal for modulating ventilation control (optional for ECON only - see vent instruction manuals)</p> | <p>▲6 Change model configuration from heat pump to heat/cool. Must be configured to programmable and fan set to be programmed fan for the "A" output to function during scheduled occupied periods. Must be configured for multi-stage for Y1 output to be active 1st stage cooling. For dehumidification, must be configured for "No Economizer" for YO/D to be active for humidity control.</p> <p>▲7 Install jumper for 1 stage electric heat on units with more than 10KW</p> <p>▲8 Do not add these wires if setting up for modulating control. See note 5.</p> <p>▲9 Factory installed jumper. Remove jumper to activate Balanced Climate™ mode. A 2-stage thermostat is recommended for Balanced Climate mode.</p> |
|---|---|

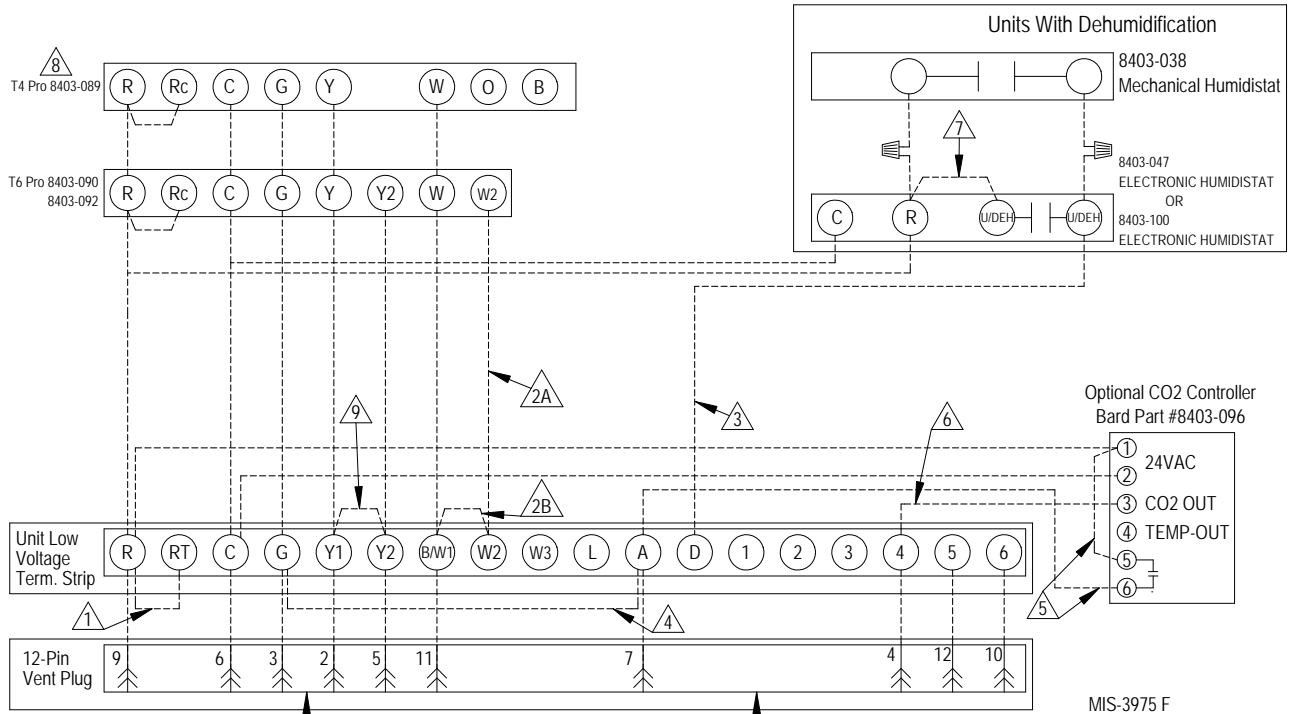
**FIGURE 11**  
**Programmable Thermostat Connections for CRV-V\* with Heat Pumps**



**ALL VENT OPTIONS PLUG IN HERE**  
*If not equipped with a ventilation option to plug in, a jumper plug must be installed.*

- ① Factory installed jumper. Remove jumper and connect to N.C fire alarm circuit if emergency shutdown required.
- ② Wire not needed below 15KW.
- ③ Wire required for dehumidification models only.
- ④ Do not connect "A" from thermostat if optional CO2 controller is used
- ⑤ 0-10 VDC modulating CO2 control signal for modulating ventilation control (optional for ECON only - see vent instruction manuals)
- ⑥ Ensure model configuration is heat pump and not heat/cool. Must be configured to programmable and fan set to be programmed fan for the "A" output to function during scheduled occupied periods. Must be configured for multi-stage for Y1 output to be active 1st stage cooling. For dehumidification, must be configured for "No Economizer" for YO/D to be active for humidity control.
- ⑦ Do not add these wires if setting up for modulating control.
- ⑧ Factory installed jumper. Remove jumper to activate Balanced Climate TM Mode. A 2-stage thermostat is recommended for balanced climate mode. Y1 Y2 jumper not present if economizer is factory installed. Units with economizers have balanced climate jumper in economizer, refer to economizer manual. The jumper is factory removed in the unit and on jade for C\*\*HY models.
- ⑨ Completestat not compatible with C\*\*HY models.

**FIGURE 12**  
**Non-Programmable Thermostat Connections for CRV-V\* with Air Conditioners**



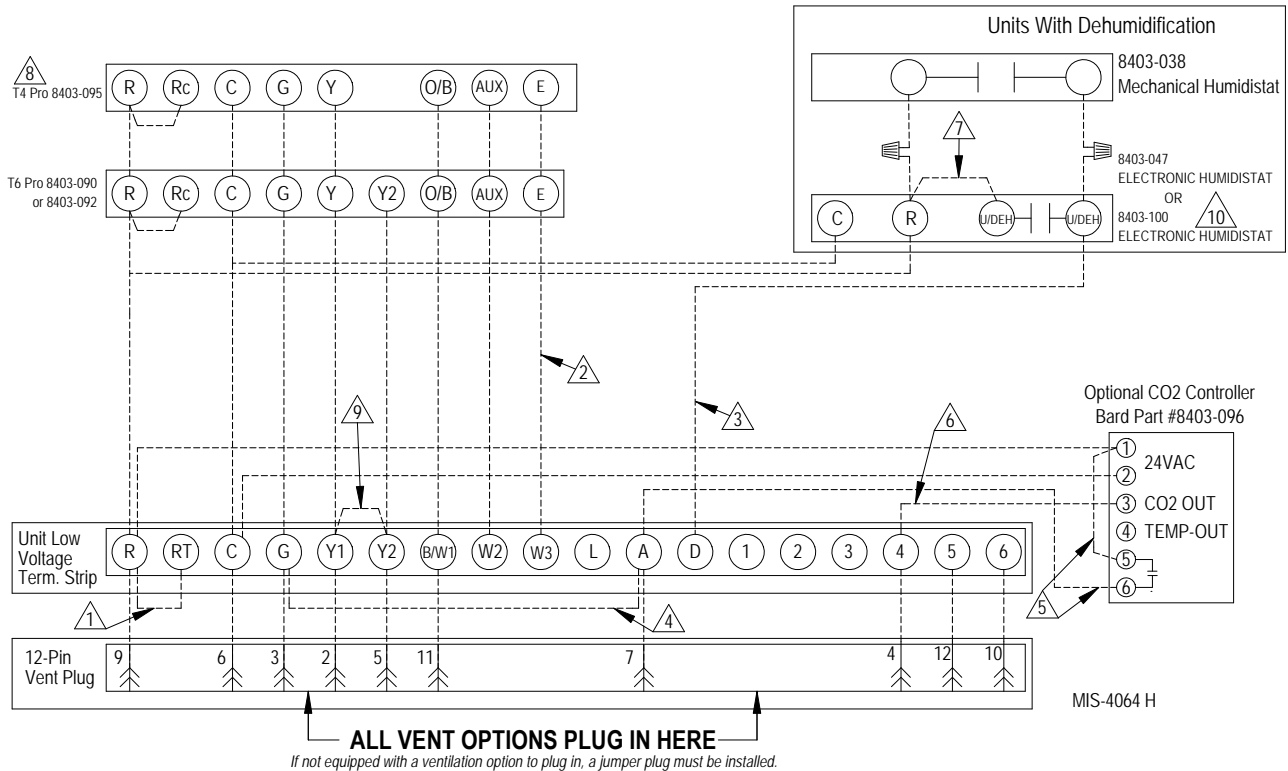
**ALL VENT OPTIONS PLUG IN HERE**  
 If not equipped with a ventilation option to plug in, a jumper plug must be installed.

- ⚠️ FACTORY INSTALLED JUMPER. REMOVE JUMPER AND CONNECT TO N.C FIRE ALARM CIRCUIT IF EMERGENCY SHUTDOWN REQUIRED.
- ⚠️ WIRE NOT NEEDED BELOW 15KW.
- ⚠️ INSTALL JUMPER FOR 1 STAGE ELECTRIC HEAT ON UNITS WITH MORE THAN 10KW.
- ⚠️ WIRE REQUIRED FOR DEHUMIDIFICATION MODELS ONLY. FOR VENT OPERATION, ADD JUMPER IF OPTIONAL CO2 CONTROLLER IS NOT USED. VENT WILL RUN WHILE BLOWER IS ENERGIZED. FOR ECON & CRV-V AN ADDITIONAL WIRE CHANGE IS REQUIRED SEE INSTALL MANUAL.
- ⚠️ DO NOT ADD THESE WIRES IF SETTING UP FOR MODULATING CONTROL. SEE NOTE 6.
- ⚠️ 0-10 VDC MODULATING CO2 CONTROL SIGNAL FOR MODULATING VENTILATION CONTROL (OPTIONAL FOR ECON ONLY) - SEE VENT INSTALLATION MANUAL.
- ⚠️ JUMPER NEEDS ADDED.
- ⚠️ THERMOSTAT WILL NOT WORK WITH UNITS EQUIPPED WITH ECONOMIZERS.
- ⚠️ FACTORY INSTALLED JUMPER. REMOVE JUMPER TO ACTIVATE BALANCED CLIMATE™ MODE. A 2-STAGE THERMOSTAT IS RECOMMENDED FOR BALANCED CLIMATE MODE. Y1 Y2 JUMPER NOT PRESENT IF ECONOMIZER IS FACTORY INSTALLED. UNITS WITH ECONOMIZERS HAVE BALANCED CLIMATE JUMPER IN ECONOMIZER. REFER TO ECONOMIZER MANUAL.
- ⚠️ HUMIDISTAT 8403-100 WILL NEED TO BE CONFIGURED FOR DEHUMIDIFICATION IN THE MENU. SEE USER'S MANUAL.

**IMPORTANT NOTE**

An additional wire change is required if jumper **4** is used which connects "A" to "G" (shown on Figures 12 and 13). The red/white wire on the blower interlock relay (located on the vent control plate) needs to be moved from the "common" terminal to the "normally closed" terminal. **If this change is not made, the relay will latch on once the "A" signal is received and the blower will not turn off.** Refer to page 11 to see the vent wiring diagram with this change called out.

**FIGURE 13**  
**Non-Programmable Thermostat Connections for CRV-V\* with Heat Pumps**



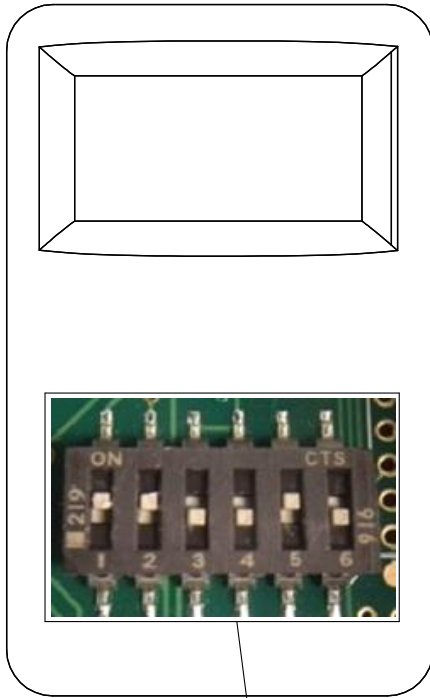
- ⚠️ 1 FACTORY INSTALLED JUMPER. REMOVE JUMPER AND CONNECT TO N.C FIRE ALARM CIRCUIT IF EMERGENCY SHUTDOWN REQUIRED.
- ⚠️ 2 WIRE NOT NEEDED BELOW 15KW.
- ⚠️ 3 WIRE REQUIRED FOR DEHUMIDIFICATION MODELS ONLY.
- ⚠️ 4 FOR VENT OPERATION. ADD JUMPER IF OPTIONAL CO2 CONTROLLER IS NOT USED. VENT WILL RUN WHILE BLOWER IS ENERGIZED. FOR ECON & CRV-V, AN ADDITIONAL WIRE CHANGE IS REQUIRED. SEE INSTALL MANUAL.
- ⚠️ 5 DO NOT ADD THESE WIRES IF SETTING UP FOR MODULATING CONTROL. SEE NOTE 6.
- ⚠️ 6 0-10 VDC MODULATING CO2 CONTROL SIGNAL FOR MODULATING VENTILATION CONTROL (OPTIONAL FOR ECON ONLY) - SEE VENT INSTALLATION MANUAL.
- ⚠️ 7 JUMPER NEEDS ADDED.
- ⚠️ 8 THERMOSTAT WILL NOT WORK WITH UNITS EQUIPPED WITH ECONOMIZERS. T4 PRO NOT COMPATIBLE WITH C\*\*HY MODELS
- ⚠️ 9 FACTORY INSTALLED JUMPER. REMOVE JUMPER TO ACTIVATE BALANCED CLIMATE™ MODE. A 2-STAGE THERMOSTAT IS RECOMMENDED FOR BALANCED CLIMATE MODE. Y1 Y2 JUMPER NOT PRESENT IF ECONOMIZER IS FACTORY INSTALLED. UNITS WITH ECONOMIZERS HAVE BALANCED CLIMATE JUMPER IN ECONOMIZER. REFER TO ECONOMIZER MANUAL. THE JUMPER IS FACTORY REMOVED IN THE UNIT AND ON JADE FOR C\*\*HY MODELS
- ⚠️ 10 HUMIDISTAT 8403-100 WILL NEED TO BE CONFIGURED FOR DEHUMIDIFICATION IN THE MENU. SEE USER'S MANUAL.

**IMPORTANT NOTE**

An additional wire change is required if jumper **4** is used which connects "A" to "G" (shown on Figures 12 and 13). The red/white wire on the blower interlock relay (located on the vent control plate) needs to be moved from the "common" terminal to the "normally closed" terminal. **If this change is not made, the relay will latch on once the "A" signal is received and the blower will not turn off.** Refer to page 11 to see the vent wiring diagram with this change called out.

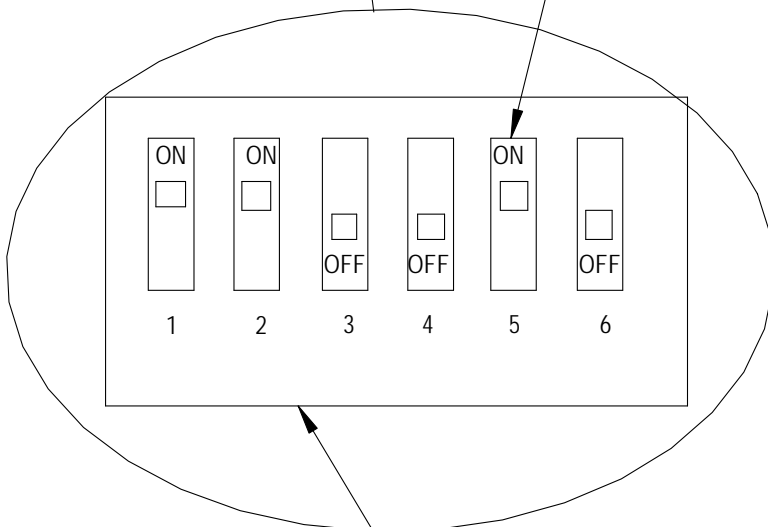
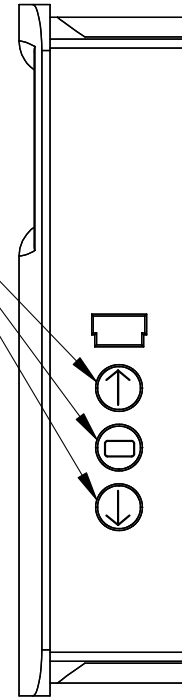


**FIGURE 14**  
**CO<sub>2</sub> Sensor Default and Final Settings**  
**Bard Part #8403-096 CO<sub>2</sub> Controller**



PRESS UP AND DOWN ARROWS TO ENTER CONFIGURATION MODE. USE ARROWS TO SELECT SETTING. PUSH MIDDLE BUTTON TO CHANGE. CONTROLLER WILL SHOW SET.

NOTE: MENU DIP SWITCH MUST BE IN "ON" POSITION #5 TO CHANGE ANY SETTINGS WITH THE SIDE BUTTONS. TO LOCK THE CO<sub>2</sub> CONTROLLER MOVE DIP SWITCH TO "OFF" AFTER IT HAS BEEN CONFIGURED.



DIP SWITCHES MUST BE POSITIONED AS SHOWN FOR PROPER OPERATION

Settings	Recommended	Default
RON (RELAY ON SET POINT)	725	
ROF (RELAY OFF SET POINT)	700	
DSP (DISPLAY CONFIGURATION)	C	CT
UNI (UNITS SELECTION)	US	US
COL (CO <sub>2</sub> LOW OUTPUT RANGE)	700	0
COH (CO <sub>2</sub> HIGH OUTPUT RANGE)	1500	2000
TOL (TEMP. LOW OUTPUT RANGE)	Not Used	
TOH (TEMP. HIGH OUTPUT RANGE)	Not Used	
BAR (BAROMETRIC PRESSURE)	See Instructions with Controller For High Altitude Installations	
CAL (CALIBRATION)	Used for Field Calibration	

MIS-4025 C

## **Blade Adjustment for Desired Ventilation Air**

The amount of ventilation air supplied by the commercial room ventilator is dependent on four factors.

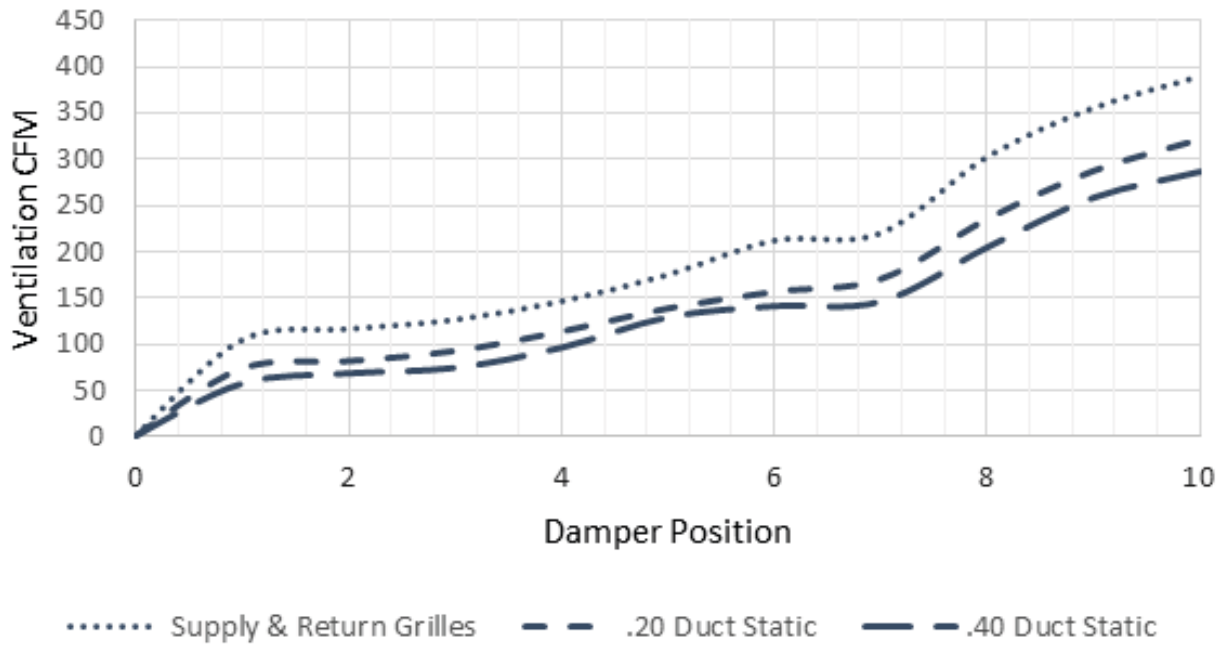
1. Return air duct static pressure drop.
2. Supply air duct static pressure drop.
3. Indoor blower motor speed.
4. Damper blade open position setting.

Refer to the appropriate graph on pages 19 and 20 to determine the blade setting necessary to achieve the ventilation air required for each operating mode.

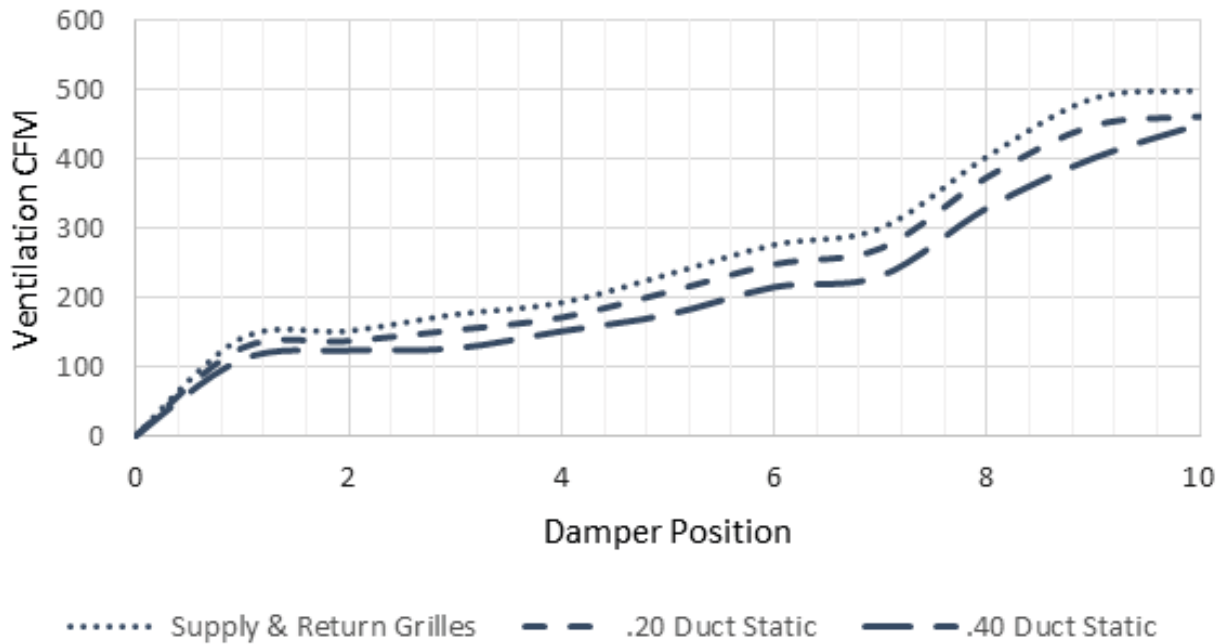
All potentiometers are set in the closed position from the factory.

Turning potentiometers counter clockwise will close the blade; clockwise will open the blade.

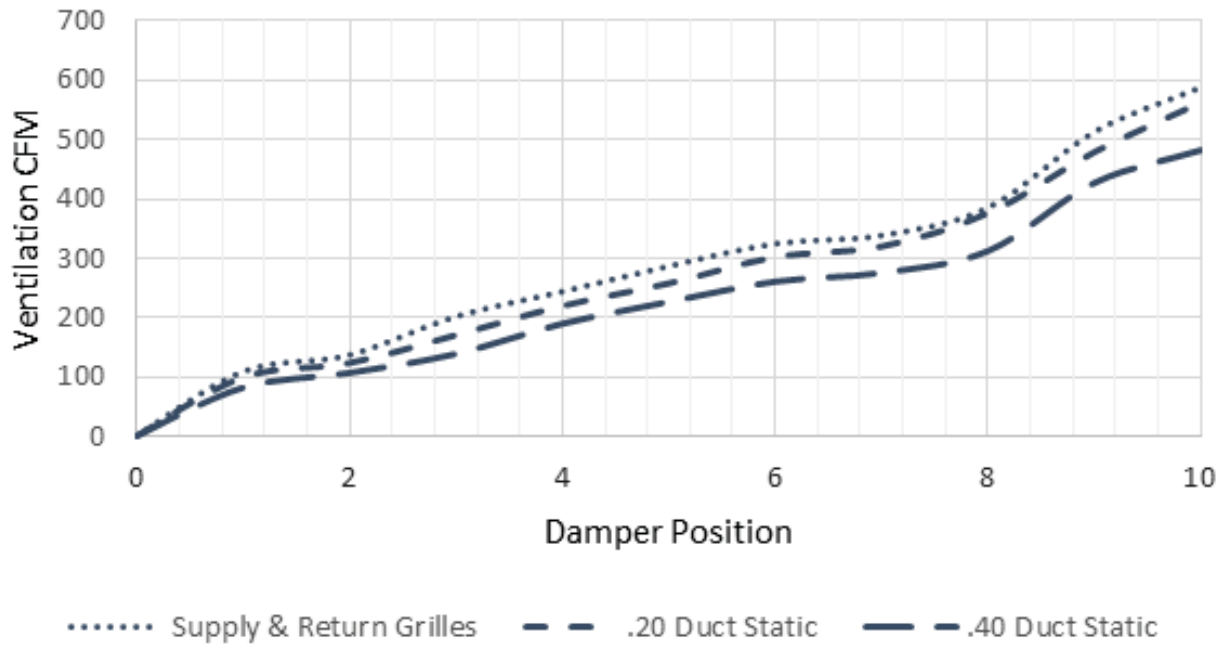
**GRAPH 1**  
**W18 Ventilation Delivery**



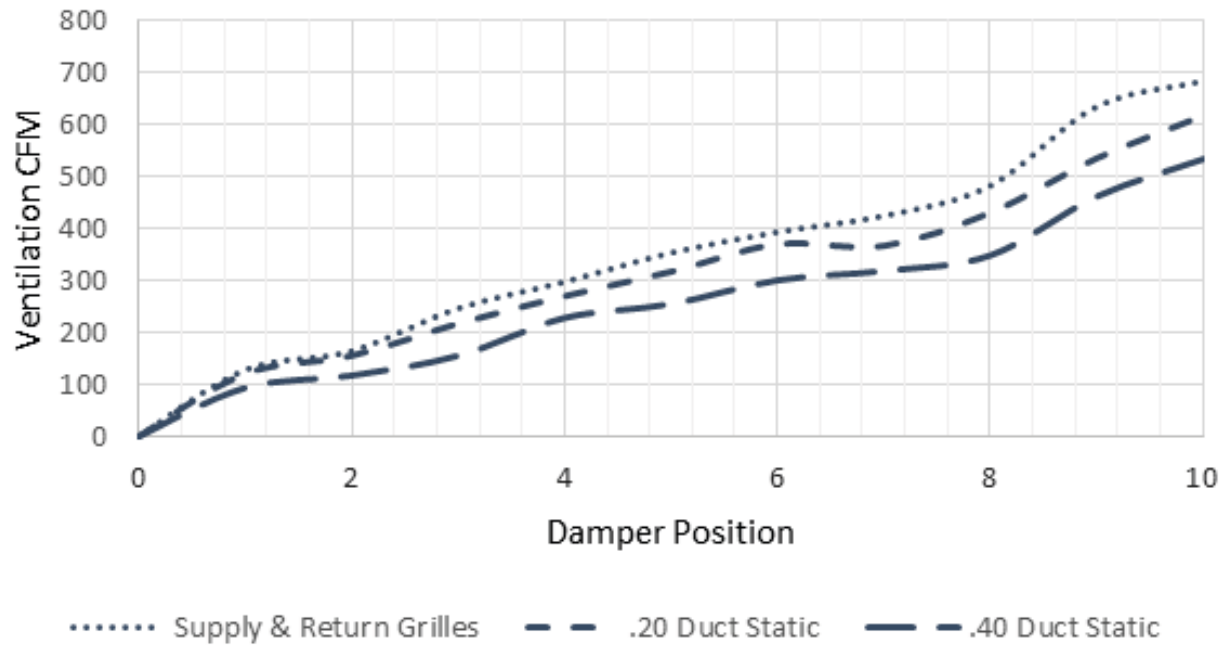
**GRAPH 2**  
**W24 Ventilation Delivery**



**GRAPH 3**  
**W30 Ventilation Delivery**



**GRAPH 4**  
**W36 Ventilation Delivery**



## "V" Option CRV Sequence of Operation

The "V" Ventilation option includes a control board with blade positioning potentiometers along with an input for a 2-10V input signal (see Figure 15).

Adjustable potentiometers:

**"PP" Potentiometer setting:** This potentiometer can be used to adjust the blade setting for outdoor air intake during a pre-purge cycle. The pre-purge cycle time is based on the setting of the pre-purge timer.

**"OCC" Potentiometer setting:** This potentiometer can be used to adjust the blade setting for outdoor air intake when the "A" terminal is energized on the low voltage terminal strip indicating occupancy.

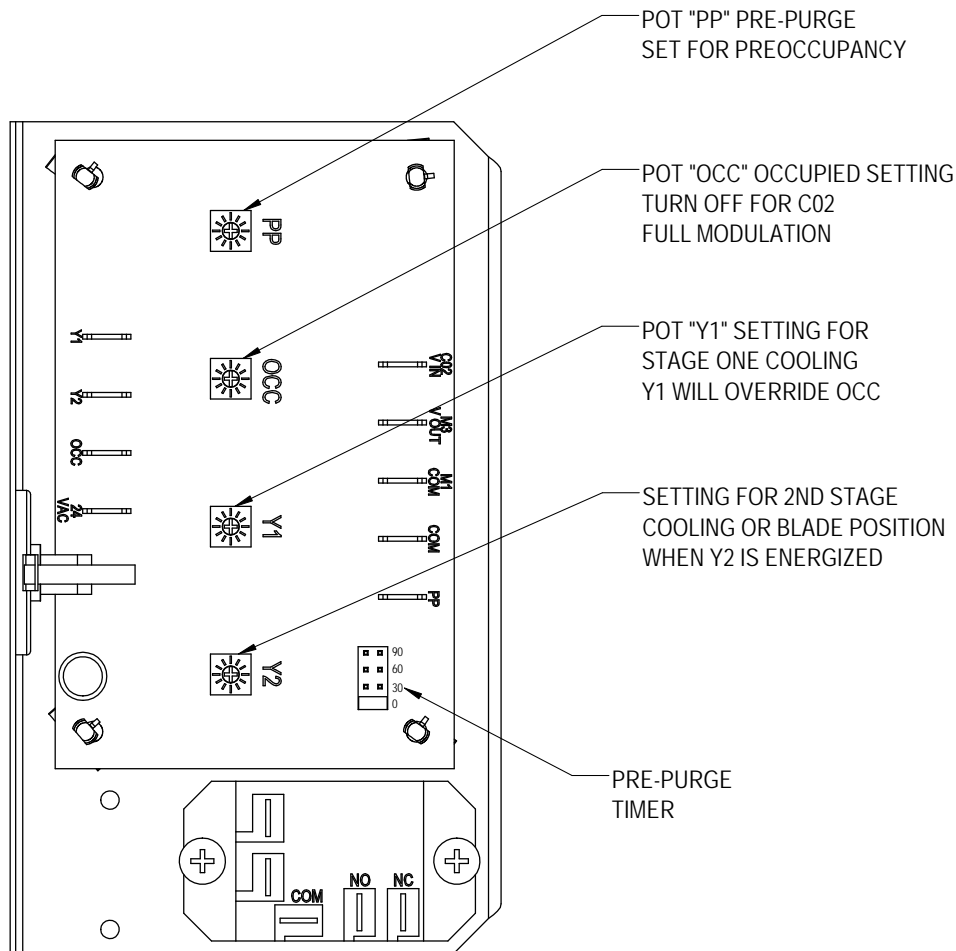
**"Y1" Potentiometer setting:** This potentiometer can be used to adjust the blade setting for outdoor air intake when the "Y1" terminal is energized on the low voltage terminal strip indicating 1st stage cooling or Balanced Climate operation. When energized, it overrides the "OCC" potentiometer setting.

**"Y2" Potentiometer setting:** This potentiometer can be used to adjust the blade setting for outdoor air intake when the "Y2" terminal is energized on the low voltage terminal strip indicating 2nd stage cooling operation. When energized, it overrides the "OCC" and "Y1" potentiometer settings.

### Pre-Purge Feature

Pre-purge is used to ventilate a specified CFM amount before occupants enter the room or structure. The control board has a built-in pre-purge timer that can be set to 30, 60 and 90 minute intervals by moving the jumper noted in Figure 15. This timer will start when the jumper is installed and the A terminal is energized on the low voltage terminal strip. Blade adjustment can be made on the PP potentiometer. Once the timer has timed out, the board will default to the occupied setting and this blade position can be adjusted on the OCC potentiometer. If the timer is set to 0 (off—shipped position), the occupied setting is instantaneous and the pre-purge setting (PP) is no longer in the sequence.

**FIGURE 15**  
**CRV Control Board**



MIS-4047

**Occupied Setting**

Occupied is used to ventilate a specified CFM amount when occupants enter the room or structure. The control board will energize the occupied setting after the pre-purge cycle, or if pre-purge is disabled immediately when the A terminal is energized on the low voltage strip. Blade adjustment can be made on the OCC potentiometer.

**Y1 Setting**

Y1 is used to ventilate a specified CFM amount when Y1 cooling is energized. If Balanced Climate operation is used, the Y1 setting should be set to a blade setting that will allow additional outdoor intake air. The control board will energize the Y1 setting when Y1 is energized on the low voltage strip. Blade adjustment can be made on the Y1 potentiometer. This potentiometer setting overrides the OCC occupied setting.

**Y2 Setting**

Y2 is used to ventilate a specified CFM amount when Y2 cooling is energized. The blade setting for the Y2

potentiometer must be set to match the occupied setting (OCC potentiometer) in order to bring in the same amount of outdoor air when non-Balanced Climate cooling occurs. The control board will energize the Y2 setting when Y2 is energized on the low voltage strip. Blade adjustment can be made on the Y2 potentiometer. This potentiometer setting overrides the OCC occupied and the Y1 setting.

**2-10V Operation**

A CO<sub>2</sub> sensor or other device sending a 2-10V signal can be used to control the damper motor. Two control methods are available to control the damper motor:

- Method 1: The control board will accept a 2-10VDC signal with a resistive load greater than 5000 ohms. Bard CO<sub>2</sub> sensor part #8403-056 can be used when the 2-10V output is connected to terminal 4 on the unit low voltage terminal strip. The occupied OCC potentiometer setting must be set to the off position for total modulation. The OCC potentiometer can be used to maintain a minimum blade position when A is energized.

**TABLE 1  
Unit Operation with V (Variable CRV) Ventilation Option**

Unit Operation	Occ. Signal	Low Voltage 24VAC							Speed Taps			Fan Speed	Comp. Oper.	Damper Pot.
		G	Y1	Y2	W1	W2	A	D	1	2	3-4-5 <sup>1</sup>			
Fan Only	Yes	X					X		X			Vent	Off	PP/OCC
Fan Only	No	X							X			Vent	Off	Closed
BC Cooling <sup>2</sup>	Yes		X				X		X	X		B Climate	On	Y1
BC Cooling <sup>2</sup>	No		X						X	X		B Climate	On	Closed
Full Load Cool	Yes		X	X			X		X	X	X	Lo/Med/Hi	On	Y2
Full Load Cool	No		X	X					X	X	X	Lo/Med/Hi	On	Closed
1st Stage Heat	Yes				X		X				X	Lo/Med/Hi	Off	Y2
1st Stage Heat	No				X						X	Lo/Med/Hi	Off	Closed
2nd Stage Heat	Yes				X	X	X				X	Lo/Med/Hi	Off	Y2
2nd Stage Heat	No				X	X					X	Lo/Med/Hi	Off	Closed
Dehumidify <sup>3</sup>	Yes						X	X	X	X		B Climate	On	Y1
Dehumidify <sup>3</sup>	No							X	X	X		B Climate	On	Closed

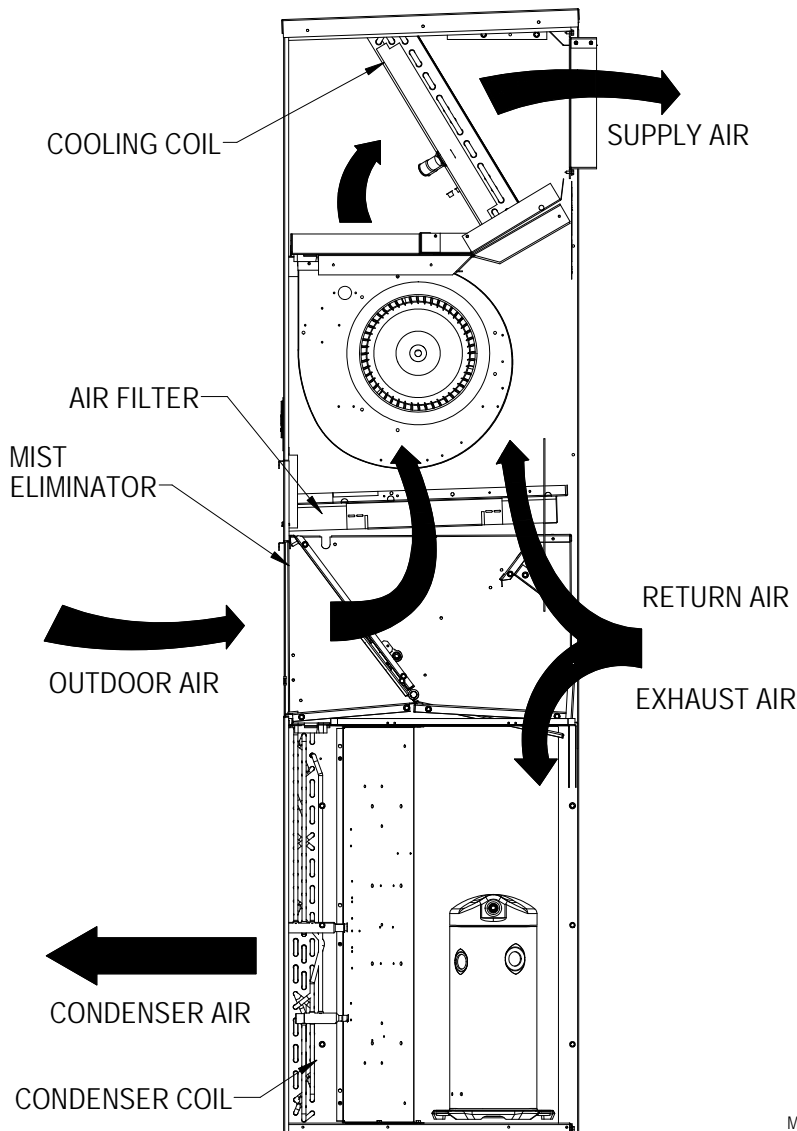
BC and B Climate – Balanced Climate

- <sup>1</sup> Fan speed is selectable through the blower speed control terminal block. LO (default), MED or HI speeds can be used.
- <sup>2</sup> Y1 and Y2 jumper must be removed on low voltage terminal block connections and 2 stage thermostat must be utilized.
- <sup>3</sup> Dehumidification operation is disabled when a call for heating or cooling occurs. Unit runs at Balanced Climate speed during dehumidification operation.

- Method 2: The damper motor will accept a 2-10VDC signal with a resistive load less than 5000 ohms. This method involves bypassing the control board and powering the motor directly from the device providing the 2-10VDC modulating signal. The gray wire from pin 4 on the 12 pin connector (2-10V IN on control board) must be spliced with the white wire ran to the damper motor (2-10V OUT on control board).

During 2-10VDC operation with A energized and pre-purge timed operation active, DC voltage signaling occupancy from a source such as a CO<sub>2</sub> sensor will increase ventilation amounts as needed.

**FIGURE 16**  
**Call for Ventilation With or Without Compressor Operation**



MIS-3866

**FIGURE 17**  
**Call for Compressor or Fan Only with Ventilation Off**

