

REPLACEMENT PARTS MANUAL

SPLIT
AIR CONDITIONER
MODELS 30ECQ4, 30ECS4, 31ECQ2, 31ECS2,
36ECQ5, 36ECS5, 37ECQ1, 37ECS1

Manual 2110-002

Revision --

Date 7-11-89

Supersedes

* GENERAL NOTES *

*Revised and/or additional pages may be issued from time to time.
*A complete and current manual consists of pages dated as shown in the following index.

** INDEX **

<u>Page Description</u>	<u>Page</u>	<u>Date</u>	<u>Supersedes</u>
Functional and Cabinet Components--Exploded View	1	7-11-89	
" " "--Usage List	2	7-11-89	

*** IMPORTANT ***

Contact the installing and/or local Bard distributor for all parts requirements. Make sure you have the complete model and serial number available from the unit rating plate.

FUNCTIONAL AND CABINET COMPONENTS

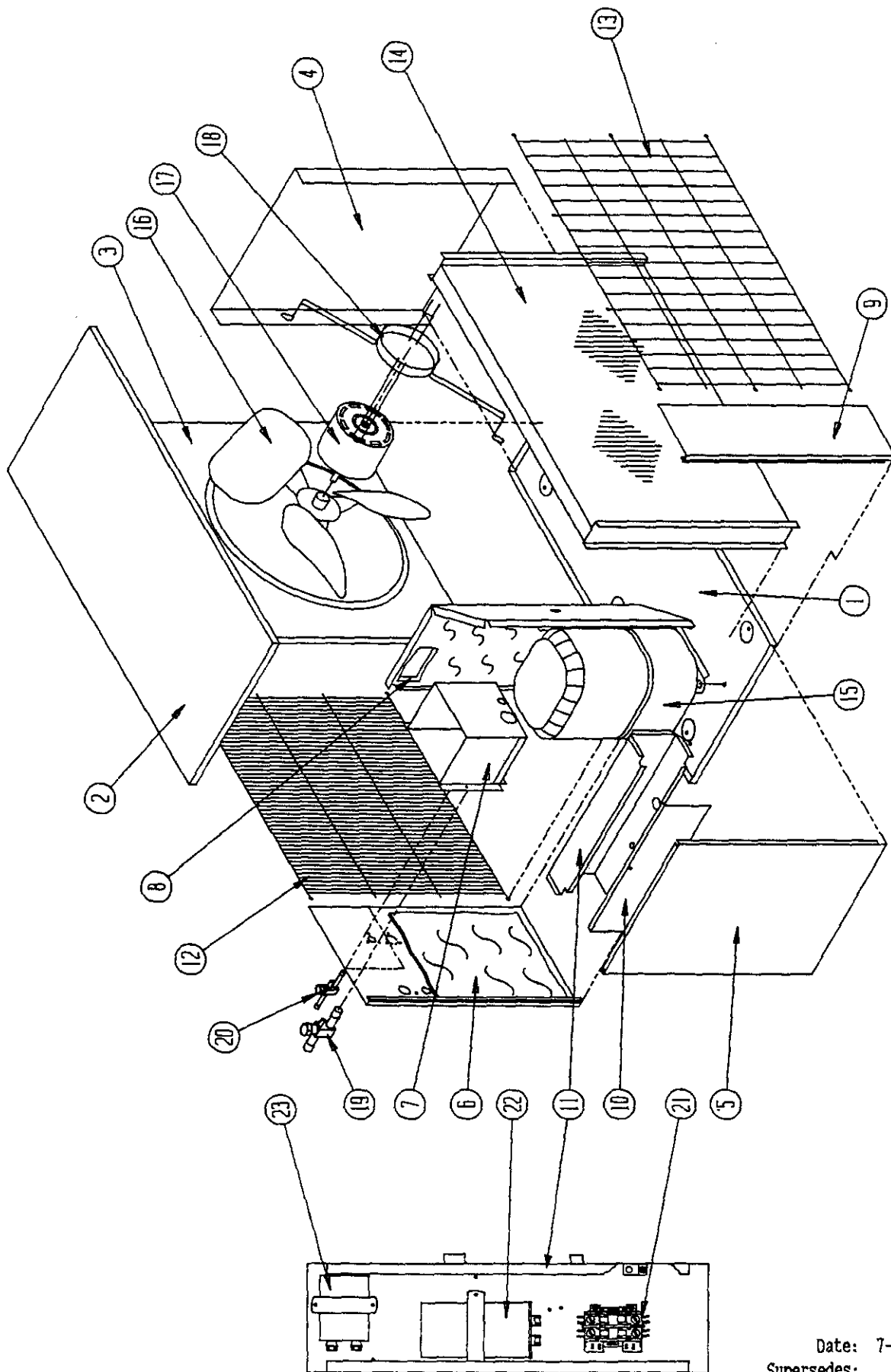

Date: 7-11-89
Supersedes:

FUNCTIONAL AND CABINET COMPONENTS

Item No.	Part No.	Description	3 0 E C Q 4	3 0 E C S 4	3 1 E C Q 2	3 1 E C S 2	3 6 E C Q 5	3 6 E C Q 5 D	3 6 E C S 5	3 7 E C Q 1	3 7 E C S 1	3 7 E C Q 1 B	3 7 E C Q 1 C	3 7 E C Q 1 E
1	127-097	Base Assembly	X	X	X	X	X	X	X	X	X	X	X	X
2	506-016	Top	X	X	X	X	X	X	X	X	X	X	X	X
3	124-009	Fan Shroud	X	X	X	X	X	X	X	X	X	X	X	X
4	100-131	Side	X	X	X	X	X	X	X	X	X	X	X	X
5	552-091	Service Door	X	X	X	X	X	X	X	X	X	X	X	X
6	548-064	Compressor Corner		X		X		X		X		X		X
6	548-046	Compressor Corner	X		X		X	X		X		X	X	X
7	140-124	base Valve Support		X		X		X		X		X		X
8	520-068	Compressor Partition	X	X	X	X	X	X	X	X	X	X	X	X
9	548-045	Coil Corner	X	X	X	X	X	X	X	X	X	X	X	X
10	132-070	Control Panel Cover	X	X	X	X	X	X	X	X	X	X	X	X
11	*	Control Panel Assembly *See Control Panel Drawing												
11	116-032	Control Panel	X	X	X	X	X	X	X	X	X	X	X	X
12	7051-003	Inlet Air Grille	X	X	X	X	X	X	X	X	X	X	X	X
13	7051-001	Condenser Grille	X	X	X	X	X	X	X	X	X	X	X	X
14	5051-034	Condenser Coil	X	X			X	X	X					
14	5051-035	Condenser Coil								X	X	X	X	X
14	5051-020	Condenser Coil			X	X								
15	8000-039	Compressor AM5540E						X						
15	8000-080	Compressor AB233FT	X	X										
15	8000-099	Compressor H23B283ABC			X	X								
15	8000-072	Compressor AV144ET					X		X					
15	8000-084	Compressor AV135ET								X	X			
15	8000-059	Compressor CRJ3-0300-TF5										X		X
15	8000-060	Compressor CRJ3-0300-TFD			X								X	
16	5151-007	Fan Blade TP2029	X	X	X	X	X	X	X	X	X	X	X	X
17	8103-009	Motor--Fan 1/5 H.P.	X	X	X	X	X	X	X	X	X	X	X	X
17	8103-014	Motor--Fan 1/5 H.P.											X	
18	8200-001	Motor Mount--Fan	X	X	X	X	X	X	X	X	X	X	X	X
19	5651-053	Base Valve		X		X		X		X				
20	5651-051	Base Valve		X		X		X		X				
21	8401-003	Contactor--Comp 30A					X		X					
21	8401-007	Contactor--Comp 25A	X	X	X	X		X		X	X			
21	8401-002	Contactor--Comp 25A 3 Pole										X	X	X
22	8552-007	Capacitor 20/15--370V	X	X										
22	8552-028	Capacitor 35/440V						X						
22	8552-030	Capacitor 40/440V					X		X					
22	8552-031	Capacitor 45/440V								X	X			
22	8552-032	Capacitor 35/370V			X	X								
23	8552-002	Capacitor 5/370V	X	X	X	X	X	X	X	X	X	X	X	X
	4062-110	Wiring Diagram	X	X										
	4062-111	Wiring Diagram			X	X	X		X	X	X			
	4062-210	Wiring Diagram										X		X
	4062-310	Wiring Diagram											X	
	4062-410	Wiring Diagram						X						

Date: 7-11-89

Supersedes: