REPLACEMENT PARTS MANUAL

QH/QW SERIES ENERGY RECOVERY VENTILATOR

Models: **QH-962139**
QW-962129

General Notes

- Revised and/or additional pages may be issued from time to time.
- A complete and current manual consists of pages shown in the following contents section.

Important

- Contact the installing and/or local Bard distributor for all parts requirements. Make sure you have the complete model and serial number available from the unit rating plates.

Contents

Description	Page
Functional & Cabinet Components	
♦ Exploded View	1
♦ Usage List	2
Cassette Components	
♦ Exploded View	3
♦ Usage List	3
Control Panel	
♦ Exploded View	4
♦ Usage List	4
Blower Assembly	
♦ Exploded View	5
♦ Usage List	5



BARD MANUFACTURING COMPANY
Bryan, Ohio 43506
Since 1914...Moving ahead, just as planned.

Manual: 2110-1002C
Supersedes: 2110-1002B
File: Tab 14
Date: 08-19-05

FUNCTIONAL and CABINET COMPONENTS

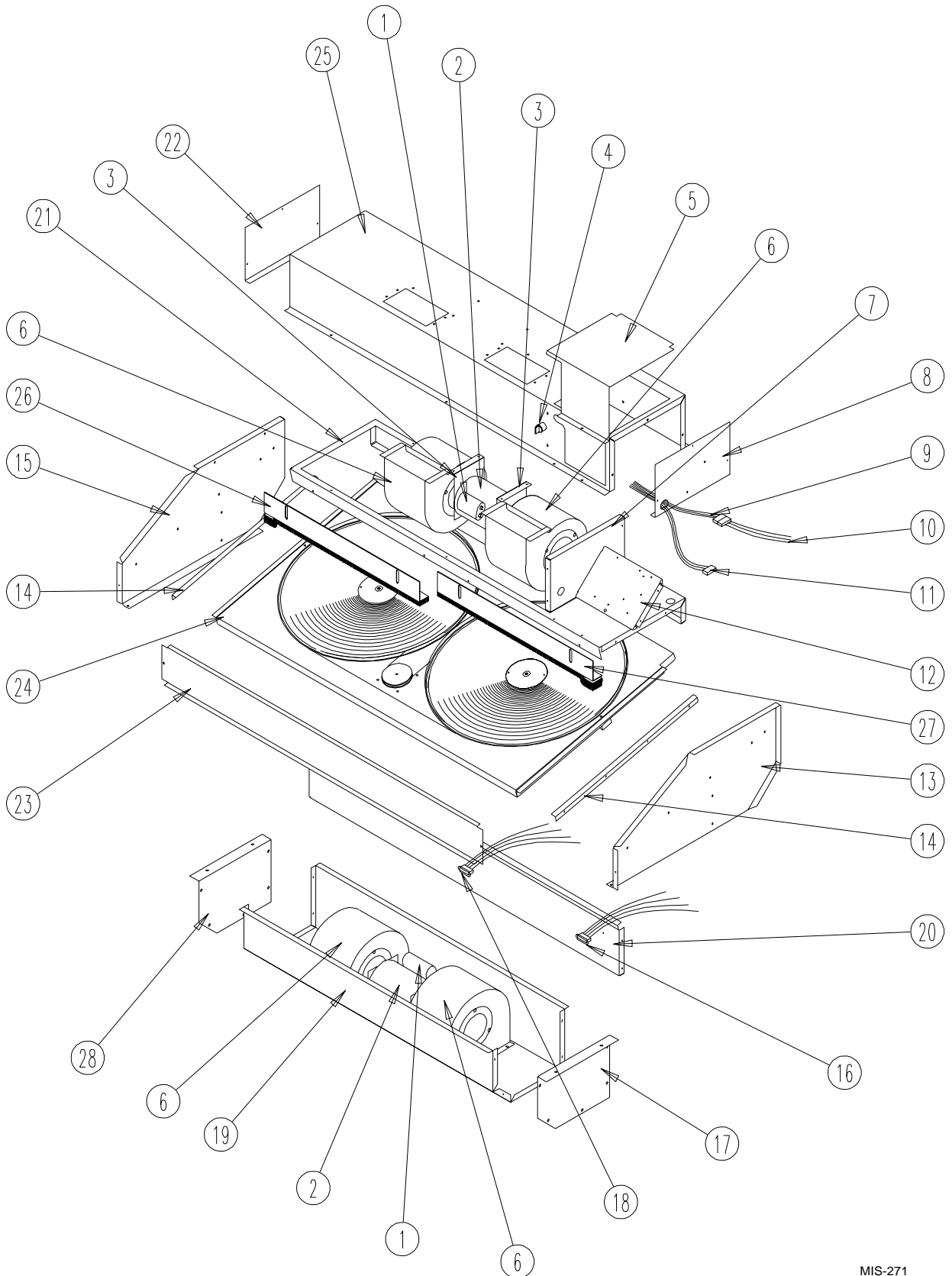

MIS-271

FUNCTIONAL and CABINET COMPONENTS

Drawing No.	Part No.	Description	962139	962129
1	8552-001	Blower Motor Capacitor	2	2
2	8101-011 	Blower Motor	2	2
3	128-018	Motor Mount	4	4
4	8406-101	Speed Switch	1	1
5	132-147	Control Panel Cover	1	1
6	Blower Housing	See Blower Housing Drawing	2	2
7	520-307	Upper Blower Box Partition	1	1
8	100-332	Right End Upper Blower Box	1	1
9	3000-1059	Wire Harness	1	1
10	3000-1048	Wire Harness	1	1
11	3000-1147	Wire Harness	1	1
12	116-193	Control Panel	1	1
13	100X331	Right End	1	1
14	104-989	Side Angle	2	2
15	100Y331	Left End	1	1
16	3000-1061	Wire Harness	1	1
17	500X278	Right End Lower Blower Box	1	
17	500X395	Right End Assembly		1
18	3000-1060	Wire Harness	1	1
19	538-084	Lower Blower Box Assembly	1	
19	538-152	Wrapper Assembly		1
20	520-318	Lower Partition Assembly	1	1
21	106-188	Top Assembly	1	1
22	500-333	Left End Upper Blower Box	1	
22	500Y395	Left End Assembly		1
23	114-111	Front Fill	1	1
24	5070-036	Cassette – Complete	1	1
25	538-133	Upper Blower Box Assembly	1	1
26	139-110	Left Seal Assembly	1	1
27	139-111	Right Seal Assembly	1	
28	500Y278	Left End Lower Blower Box	1	1
NS	3000-1073	Wire Harness	1	1
NS	538-151	Exhaust Duct Assembly		1
NS	4056-157	Wiring Diagram	1	1

NS Not Shown

CASSETTE COMPONENTS

Drawing No.	Part No.	Description	962129 962139
1	539-168	Cassette Plate Assembly	1
2	104-1127	Right Support Angle	1
3	104-1128	Left Support Angle	1
4	S140-288	Support Bar Assembly	1
5	5070-043	Cassette Wheel	2
6	5501-019	Pulley	1
7	8101-016	Motor	1
8	142-104	Hub Cover	2
9	1912-012	Wheel Shaft	2
10	5070-024	Drive Belt	1
11	S5070-047	Center Block Assembly	1
12	1012-164	Machine Screw	4
13	8611-111	Nylon Spacer	4

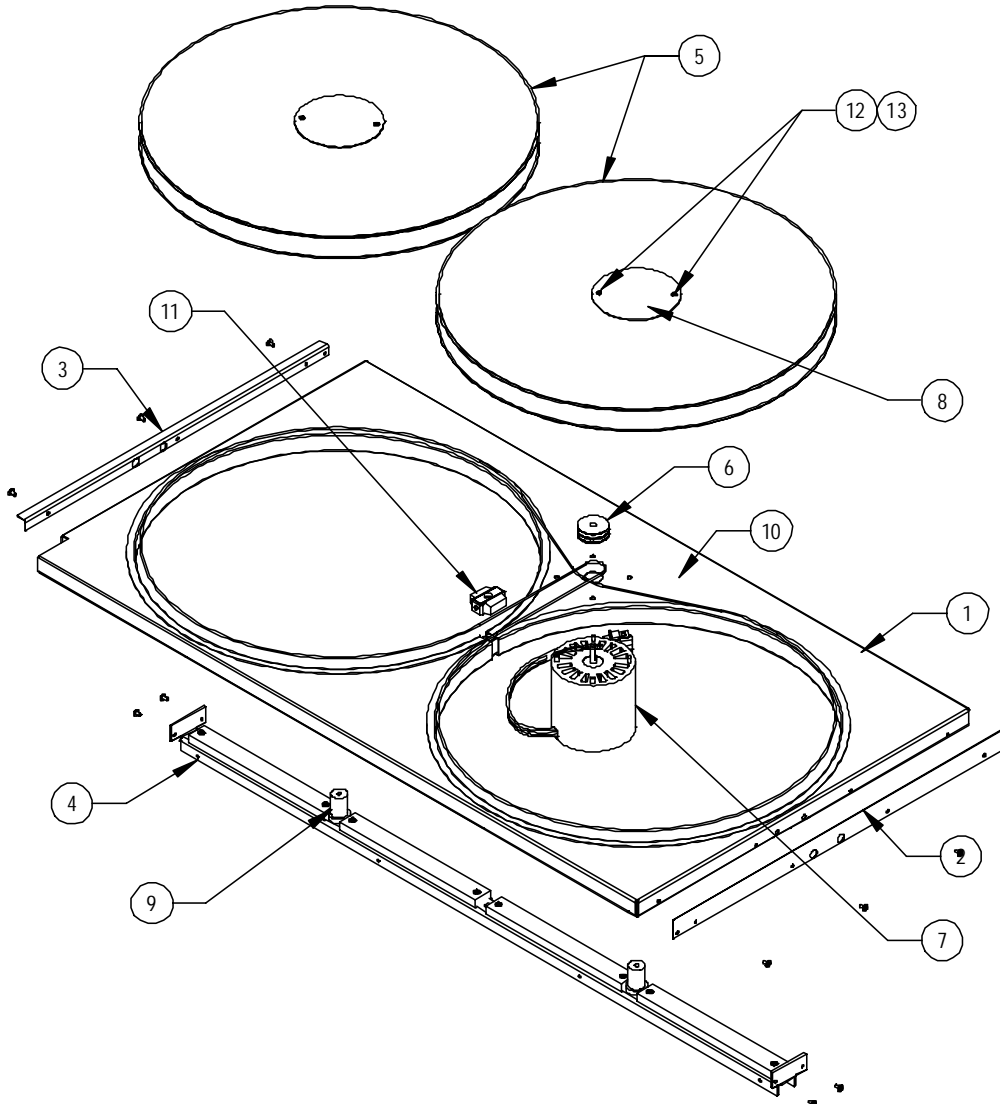

SEXP-405

CONTROL PANEL

Drawing No.	Part No.	Description	962129 962139
1	116-193	Control Panel	1
2	8201-008	Blower Relay	1
3	8552-070	Cassette Motor Capacitor	1
4	8407-043	Transformer	1
5	8607-017	Terminal Block	1
NS	8406-101	Speed Switch	1

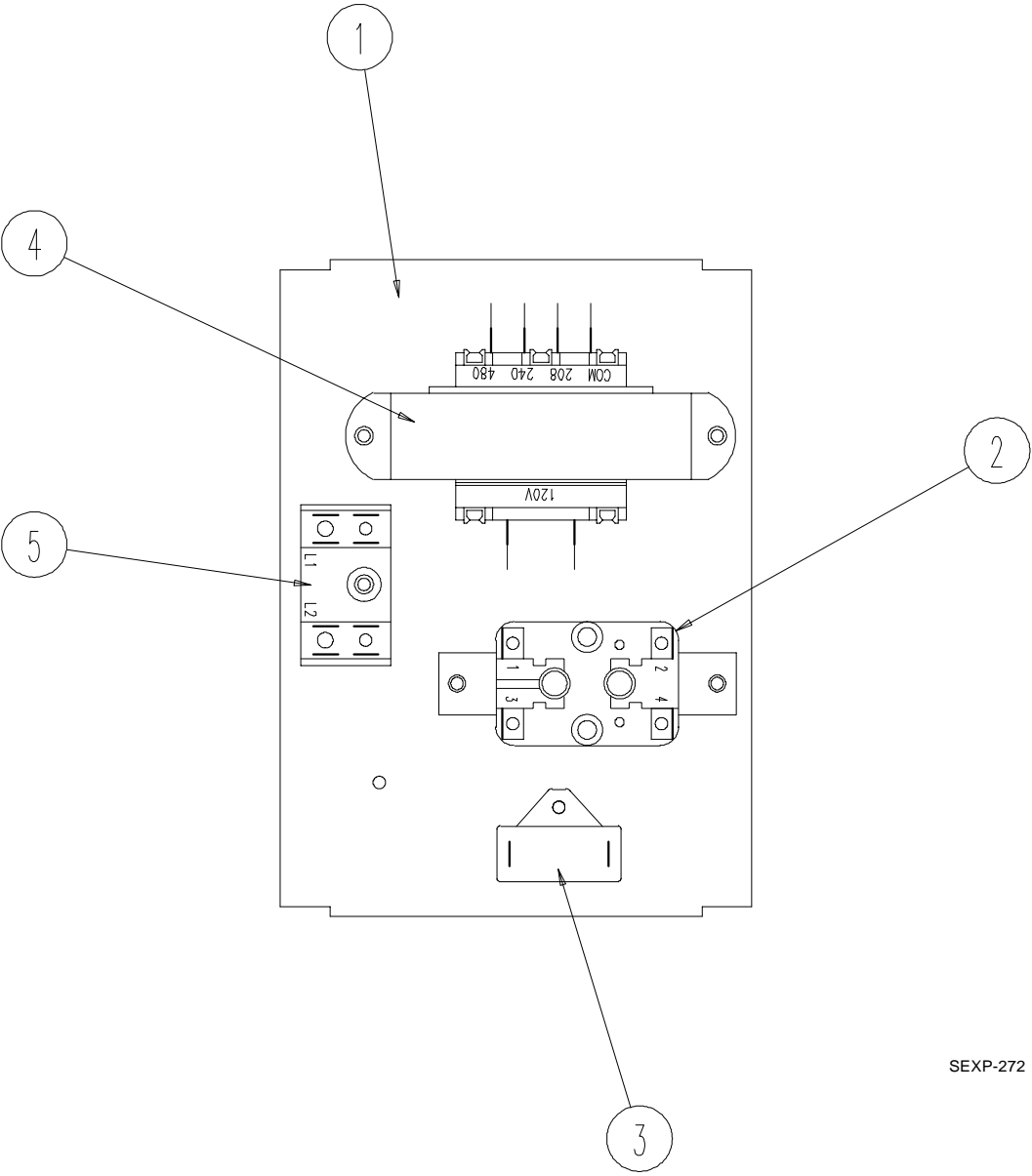

SEXP-272

BLOWER ASSEMBLY

Drawing No.	Part No.	Description	962129 962139
1	5152-078	Blower Wheel	1
2	5152-080	Inlet Ring	2
3	5152-079	Blower Housing	1

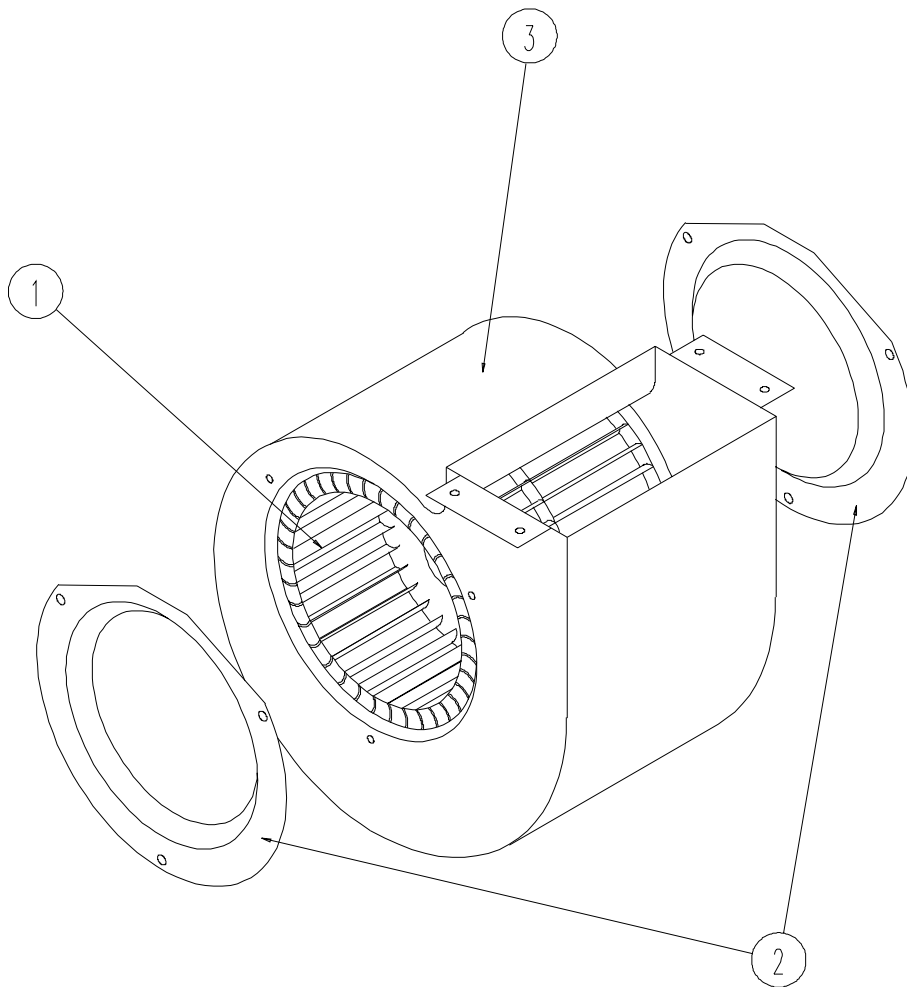

SEXP-218