

---

# REPLACEMENT PARTS MANUAL

---

## QH/QW SERIES ENERGY RECOVERY VENTILATOR

Models:

QH 920-0031    QW 920-0032

---

### General Notes

- Revised and/or additional pages may be issued from time to time.
- A complete and current manual consists of pages shown in the following contents section.

### Important

- Contact the installing and/or local Bard distributor for all parts requirements. Make sure to have the complete model and serial number available from the unit rating plates.

### Contents

<u>Description</u>	<u>Page</u>
Functional and Cabinet Components	
♦ Exploded View.....	2
♦ Usage List .....	3
Cassette Components	
♦ Exploded View.....	4
♦ Usage List .....	4
Control Panel	
♦ Layout View .....	5
♦ Usage List .....	5
Blower Assembly	
♦ Layout View .....	6
♦ Usage List .....	6



*Climate Control Solutions*

Bard Manufacturing Company, Inc.  
Bryan, Ohio 43506  
www.bardhvac.com

Manual: 2110-1003C  
Supersedes: 2110-1003B  
Date: 2-23-18

# FUNCTIONAL and CABINET COMPONENTS

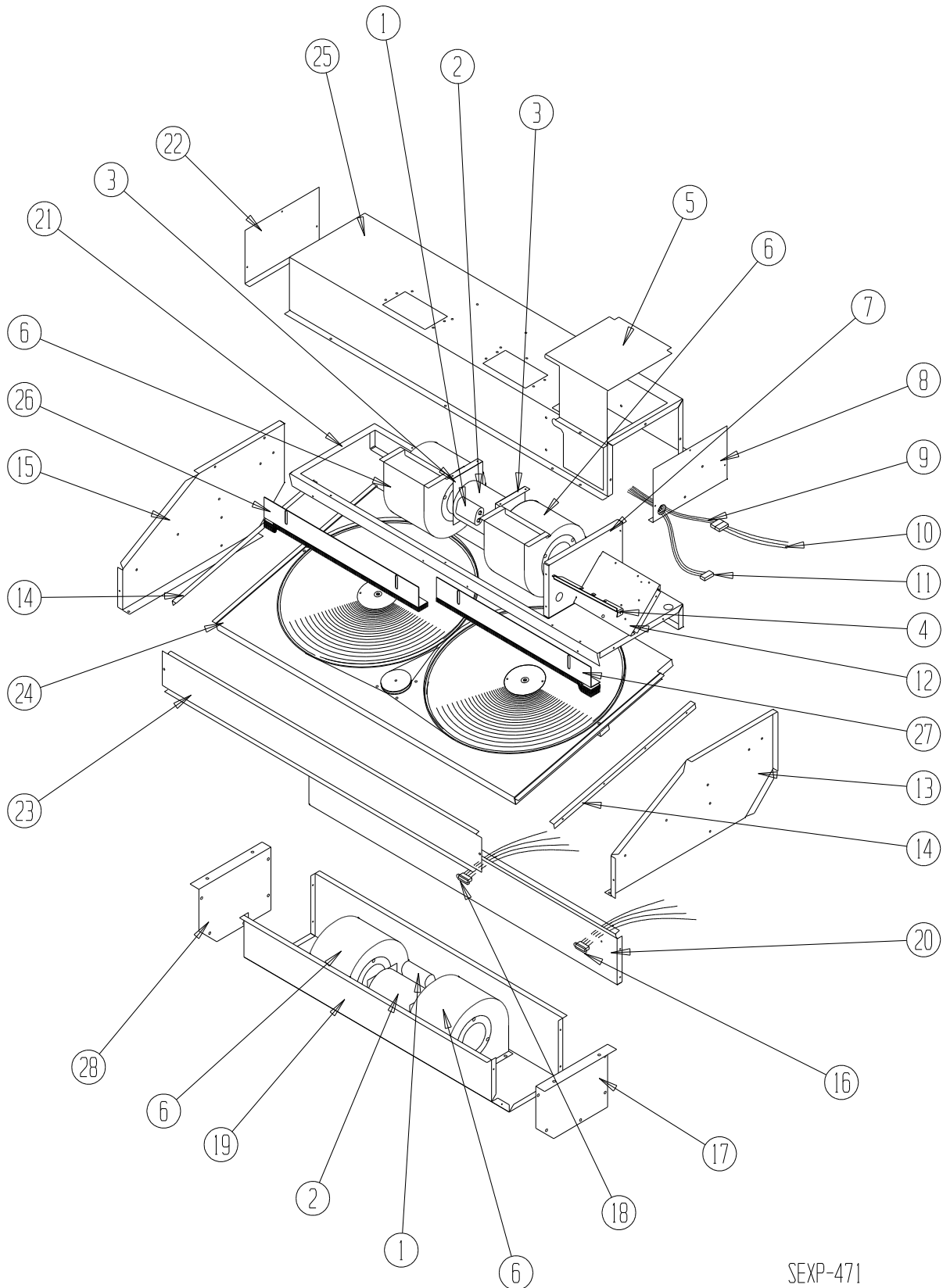

SEXP-471

## FUNCTIONAL and CABINET COMPONENTS

Drawing No.	Part No.	Description	920-0031	920-0032
1	8552-001	Blower Motor Capacitor	2	2
2	8101-024	Blower Motor	2	2
3	128-018	Motor Mount	4	4
4	S910-1637	Terminal Block Assembly	1	1
5	132-147	Control Panel Cover	1	1
6	Blower Housing	See Blower Housing Drawing	2	2
7	520-307	Upper Blower Box Partition	1	1
8	100-332	Right End Upper Blower Box	1	1
9	3000-1059	Wire Harness	1	1
10	3000-1048	Wire Harness	1	1
11	3000-1147	Wire Harness	1	1
12	116-193	Control Panel	1	1
13	100X331	Right End	1	1
14	104-989	Side Angle	2	2
15	100Y331	Left End	1	1
16	3000-1061	Wire Harness	1	1
17	500X278	Right End Lower Blower Box	1	
17	500X395	Right End Assembly		1
18	3000-1060	Wire Harness	1	1
19	538-084	Lower Blower Box Assembly	1	
19	538-152	Wrapper Assembly		1
20	520-318	Lower Partition Assembly	1	1
21	106-188	Top Assembly	1	1
22	500-333	Left End Upper Blower Box	1	
22	500Y395	Left End Assembly		1
23	114-111	Front Fill	1	1
24	5070-036	Cassette – Complete	1	1
25	538-183	Upper Blower Box Assembly	1	1
26	139-110	Left Seal Assembly	1	1
27	139-111	Right Seal Assembly	1	
28	500Y278	Left End Lower Blower Box	1	1
NS	3000-1073	Wire Harness	1	1
NS	538-151	Exhaust Duct Assembly		1
NS	4056-157	Wiring Diagram	1	1

NS = Not Shown

# CASSETTE COMPONENTS

Drawing No.	Part No.	Description	920-0031 920-0032
1	539-168	Cassette Plate Assembly	1
2	104-1127	Right Support Angle	1
3	104-1128	Left Support Angle	1
4	S140-288	Support Bar Assembly	1
5	5070-043	Cassette Wheel	2
6	5501-019	Pulley	1
7	8101-016	Motor	1
8	142-104	Hub Cover	2
9	1912-012	Wheel Shaft	2
10	8620-196	Drive Belt & Pulley Kit	2
11	S5070-047	Center Block Assembly	1
12	1012-164	Machine Screw	4
13	8611-111	Nylon Spacer	4
NS	5070-052	3/4" Bearing/Hub Assembly	2
NS	8620-204 ①	Bearing/Hub, Shaft & Hardware Kit	2
NS	8620-205 ②	Shaft & Hardware Kit	2

NS = Not Shown

① = Contains Item #'s 8, 9, 12, 13 and "NS" Bearing + Additional Hardware

② = Contains Item #'s 8, 9, 12, 13 + Additional Hardware

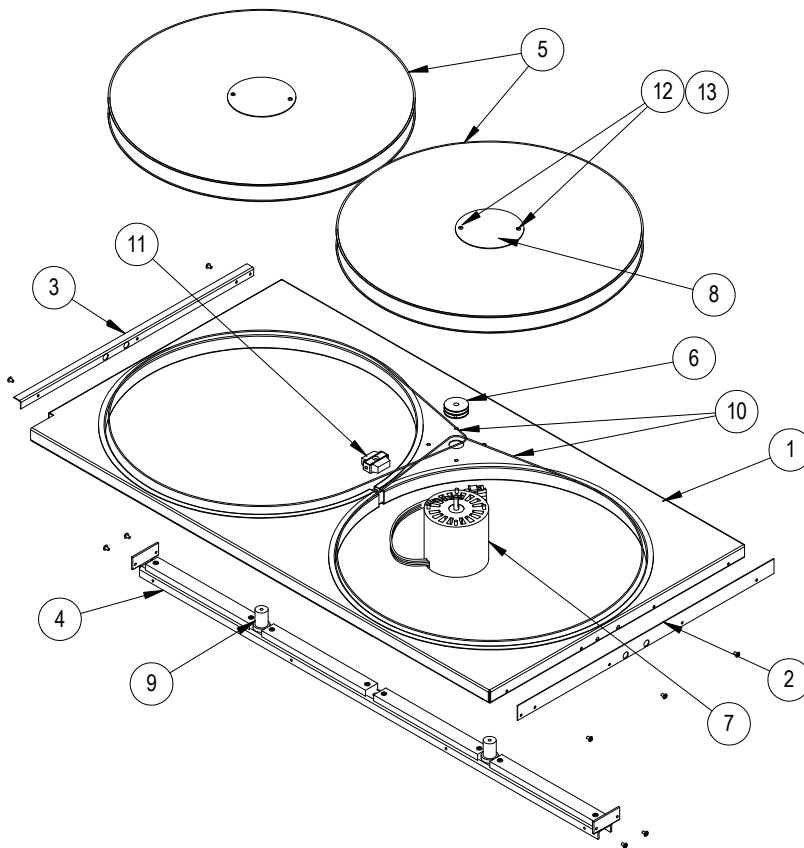

SEXP-472

# CONTROL PANEL

Drawing No.	Part No.	Description	920-0031 920-0032
1	116-193	Control Panel	1
2	8201-008	Blower Relay	1
3	8552-100	Cassette Motor Capacitor	1
4	8407-043	Transformer	1
5	8607-017	Terminal Block	1
NS	8406-101	Speed Switch	1

NS = Not Shown

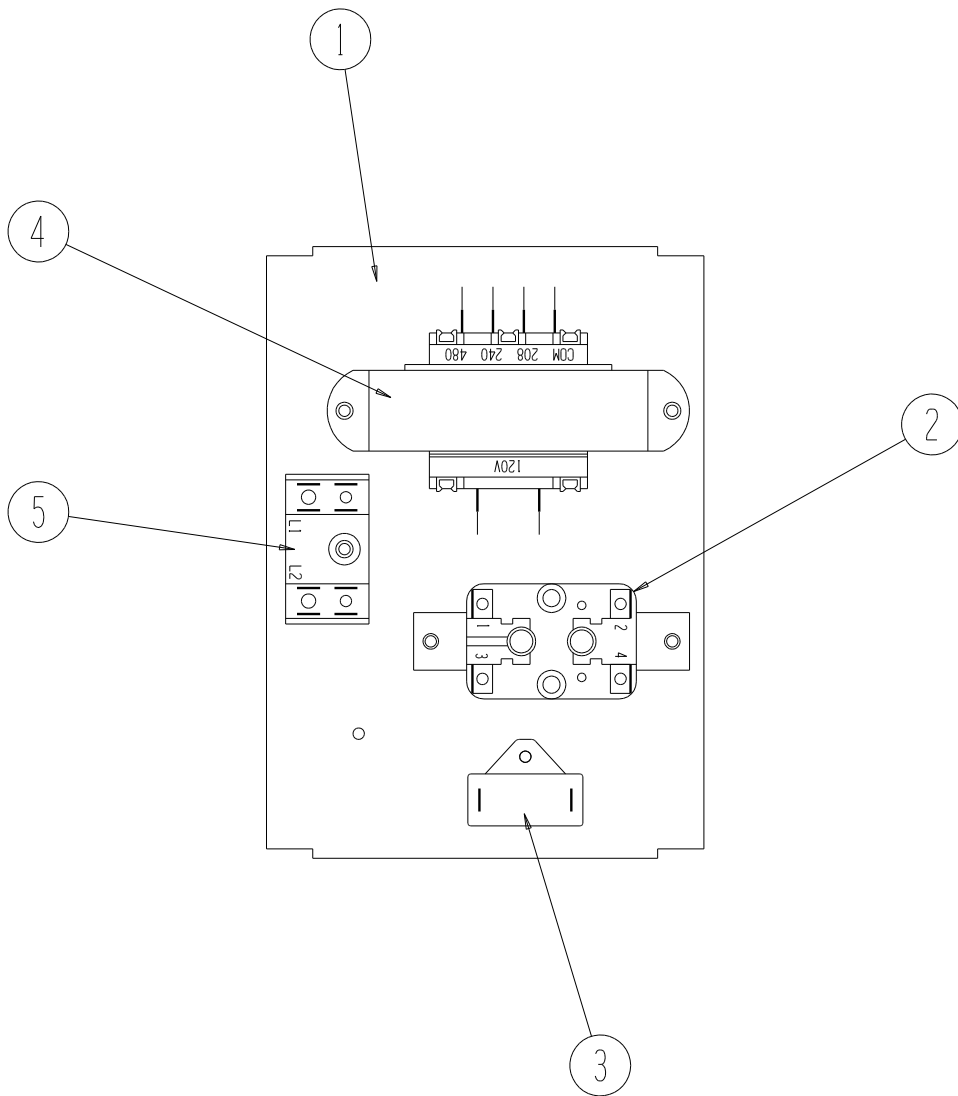

# BLOWER ASSEMBLY

---

Drawing No.	Part No.	Description	920-0031	920-0032
1	5152-078	Blower Wheel	1	
2	144-188	Inlet Ring	2	
3	151-119	Blower Housing	1	

