REPLACEMENT PARTS MANUAL

QW*S SERIES ENERGY RECOVERY VENTILATOR

Models:

920-0074 920-0138 920-0239

General Notes

- Revised and/or additional pages may be issued from time to time.
- A complete and current manual consists of pages shown in the following contents section.

Important

- Contact the installing and/or local Bard distributor for all parts requirements. Make sure to have the complete model and serial number available from the unit rating plates.

Contents

<u>Description</u>	<u>Page</u>
Functional and Cabinet Components	
♦ Exploded View.....	2
♦ Usage List	3
Blower Assembly	
♦ Exploded View.....	4
♦ Usage List	4
Cassette Components	
♦ Exploded View.....	5
♦ Usage List	5
Control Panel	
♦ Layout View	6
♦ Usage List	6
Control Panel	
♦ Layout View	7
♦ Usage List	7



Climate Control Solutions

Bard Manufacturing Company, Inc.
Bryan, Ohio 43506
www.bardhvac.com

Manual: 2110-1004D
Supersedes: 2110-1004C
Date: 2-23-18

FUNCTIONAL AND CABINET COMPONENTS

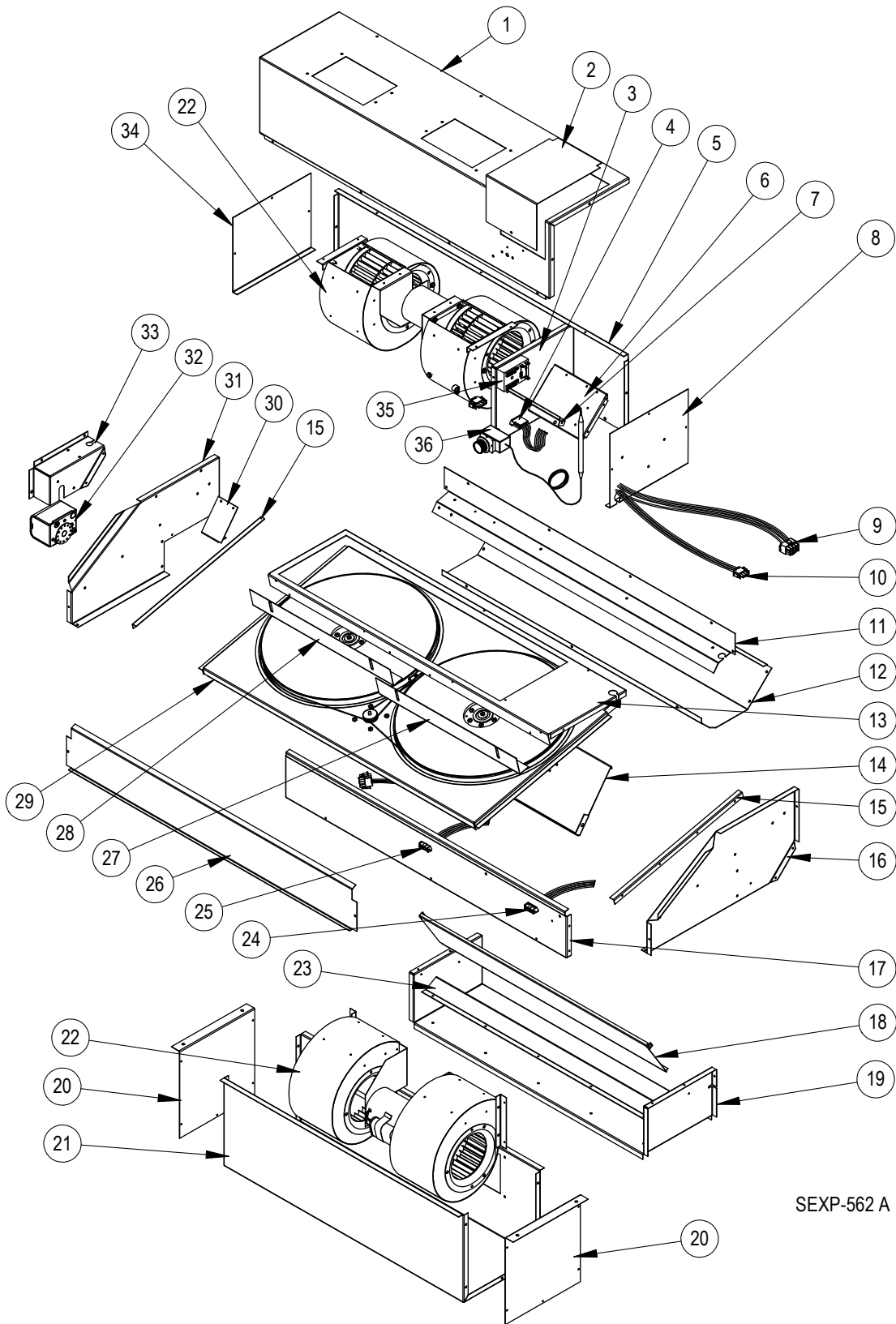

SEXP-562 A

FUNCTIONAL AND CABINET COMPONENTS

Drawing No.	Part No.	Description	920-0074	920-0138	920-0239
1	539-216	Blower Box Assembly	1	1	1
2	133-202	Control Panel Cover	1	1	1
3	521-440	Blower Box Partition Assembly	1	1	1
4	3000-1341	Wire Harness	1	1	1
5	539-217	Upper Blower Wrapper Back Assembly	1	1	1
6	Control Panel	See Control Panel Assembly	1	1	1
7	S910-1637	Terminal Block Assembly	1	1	1
8	101-566	Right Blower Box End	1	1	1
9	3000-1342	Wire Harness	1	1	
9	3000-1466	Wire Harness			1
10	3000-1059	Wire Harness	1	1	1
11	S137-590	Upper Intake Fill Plate	1	1	1
12	127-385	Base Plate	1	1	1
13	107-280	Top	1	1	1
14	139-349	Intake Damper Blade	1	1	1
15	104-989	Side Angle	2	2	2
16	S101-583	Right End	1	1	1
17	S521-446	Lower Partition Assembly	1	1	1
18	139-226	ERV Exhaust Blade	1	1	1
19	S139-225	ERV Exhaust Wrapper	1	1	1
20	501-572	End Assembly	2	2	2
21	539-218	Wrapper Assembly	1	1	1
22	Blower Assembly	See Blower Assembly Drawing	2	2	2
23	S139-228	Blade Sealing Angle	1	1	1
24	3000-1061	Wire Harness	1	1	1
25	3000-1343	Wire Harness	1	1	1
26	115-169	Front Fill	1	1	1
27	139-111	Right Seal Assembly	1	1	1
28	139-110	Left Seal Assembly	1	1	1
29	5070-036	Cassette – Complete	1	1	1
30	137-821	Left Side Intake Fill Plate	1	1	1
31	S101-582	Left End	1	1	1
32	8110-002	Damper Motor	1	1	1
33	113-385	Damper Motor Bracket	1	1	1
34	501-567	Left Blower Box End Assembly	1	1	1
35	8201-134	Recycle Timer		1	
36	8408-028	Thermostat		1	
NS	4114-100	Wiring Diagram	1		
NS	4114-102	Wiring Diagram		1	
NS	4114-104	Wiring Diagram			1

NS = Not Shown

BLOWER ASSEMBLY

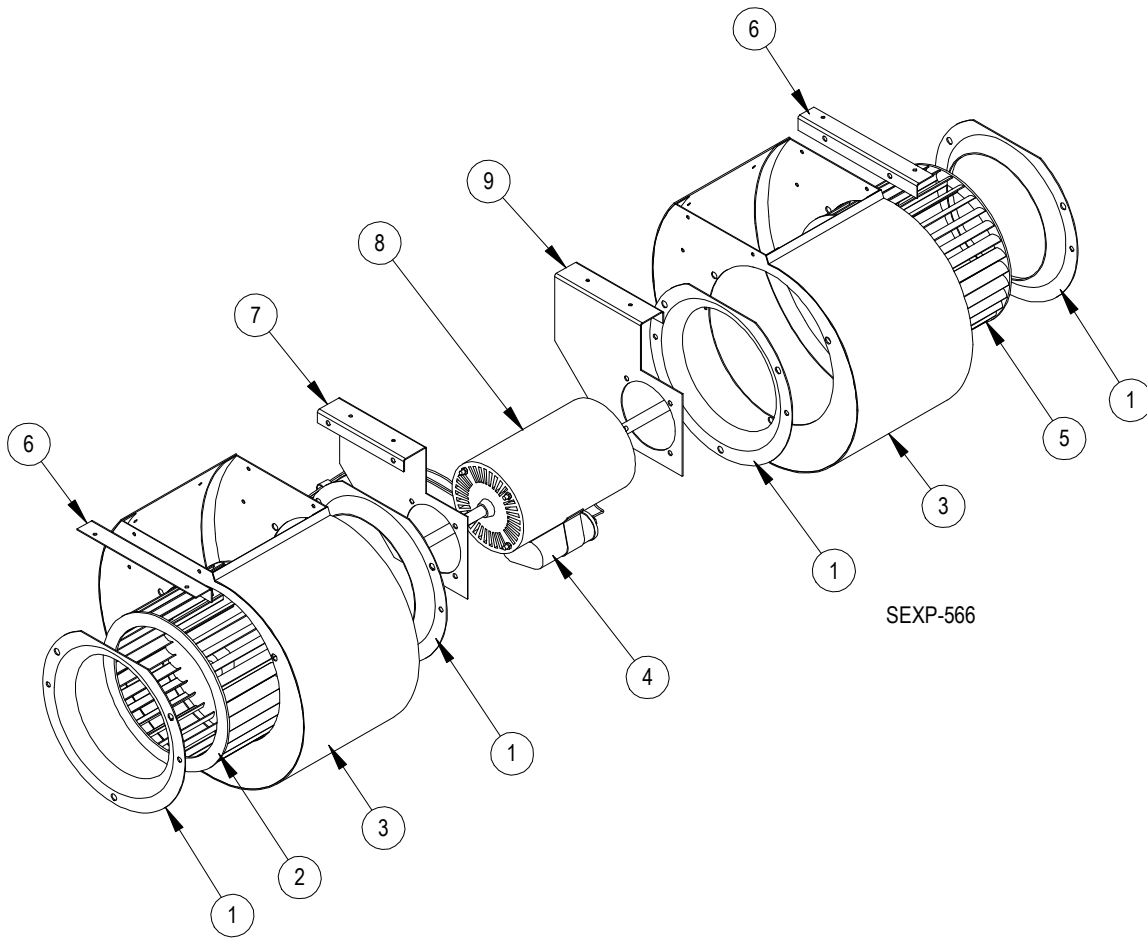

Drawing No.	Part No.	Description	920-0074 920-0138
1	144-180	Inlet Plate	4
2	5152-100	Blower Wheel	1
3	151-114	Blower Housing Assembly	2
4	8552-002	Blower Motor Capacitor	1
5	5152-101	Blower Wheel	1
6	105-1084	Blower Side Angle	2
7	113X274	Right Blower Motor Support	1
8	8101-019	Blower Motor	1
9	113Y274	Left Blower Motor Support	1

CASSETTE COMPONENTS

920-0074
920-0138

Drawing No.	Part No.	Description	
1	539-168	Cassette Plate Assembly	1
2	104-1127	Right Support Angle	1
3	104-1128	Left Support Angle	1
4	S140-288	Support Bar Assembly	1
5	5070-043	Cassette Wheel	2
6	5501-019	Pulley	1
7	8101-016	Motor	1
8	142-104	Hub Cover	2
9	1912-012	Wheel Shaft	2
10	8620-196	Drive Belt & Pulley Kit	2
11	S5070-047	Center Block Assembly	1
12	1012-164	Machine Screw	4
13	8611-111	Nylon Spacer	4
NS	5070-052	3/4" Bearing/Hub Assembly	2
NS	8620-204 ①	Bearing/Hub, Shaft & Hardware Kit	2
NS	8620-205 ②	Shaft & Hardware Kit	2

NS = Not Shown

① = Contains Item #'s 8, 9, 12, 13 and "NS" Bearing + Additional Hardware

② = Contains Item #'s 8, 9, 12, 13 + Additional Hardware

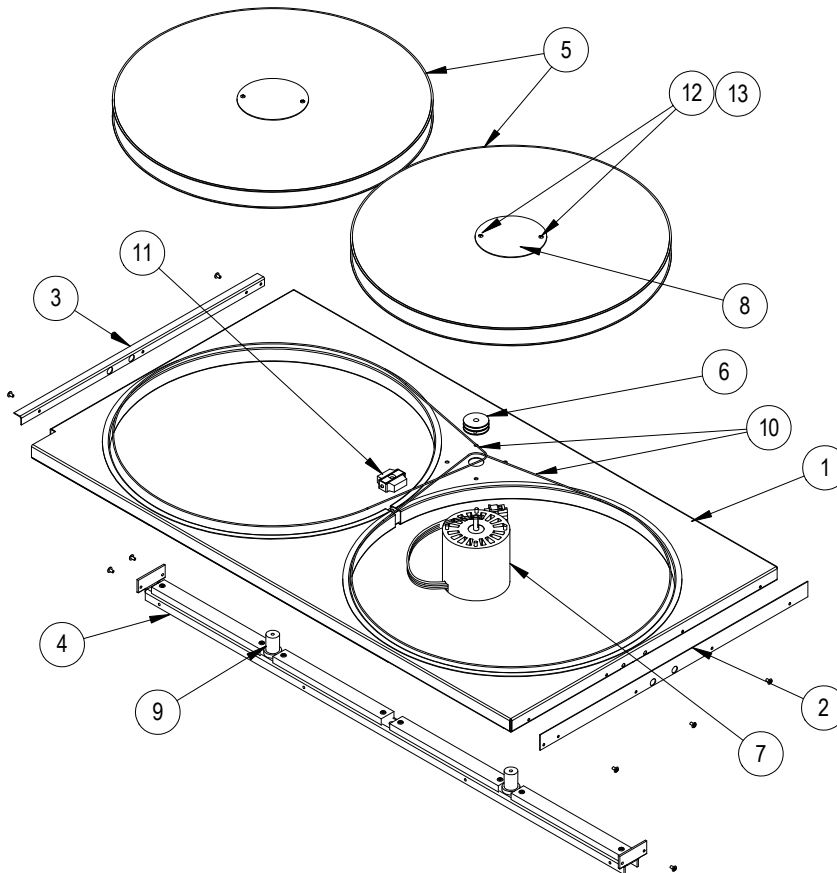

SEXP-472

CONTROL PANEL

920-0074
920-0138

Drawing No.	Part No.	Description	
1	116-193	Control Panel	1
2	8201-008	Blower Relay	1
3	8552-100	Cassette Motor Capacitor	1
4	8407-043	Transformer	1
5	8607-017	Terminal Block	1

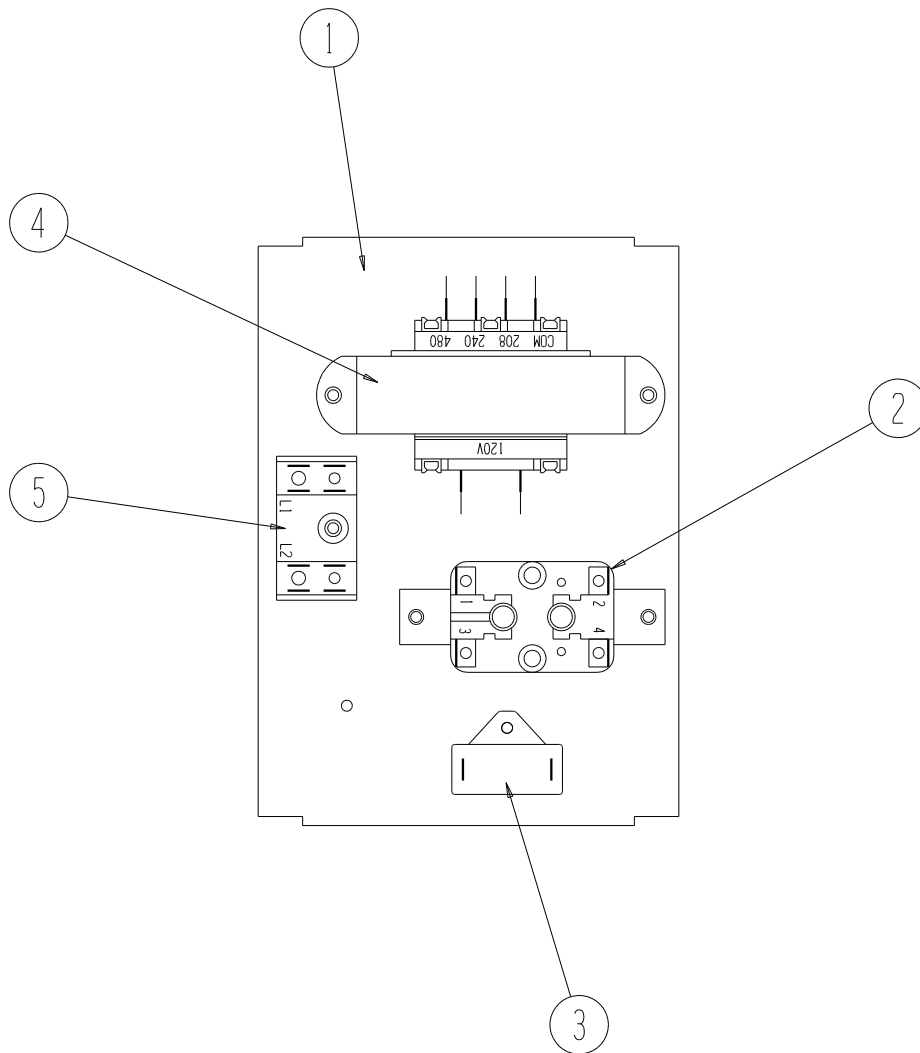

SEXP-272

CONTROL PANEL

920-0239

Drawing No.	Part No.	Description	
1	116-360	Control Panel	1
2	8407-043	Transformer	1
3	8201-150	Relay, DPDT	2
4	8201-130	Relay, SPST (NO), 8 FLA @ 250V	1
5	8552-100	Capacitor 3MFD 250VAC	1
6	8607-017	Terminal Block 240V 2 Terminal	1

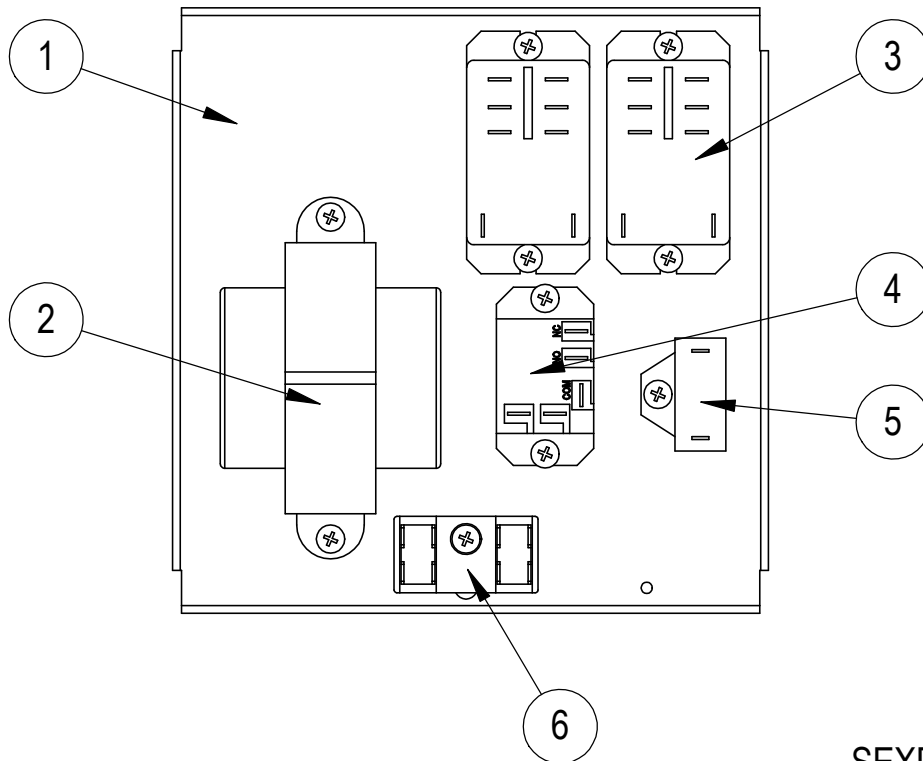

SEXP-721