REPLACEMENT PARTS MANUAL

WALL MOUNTED GAS/ELECTRIC ENERGY RECOVERY VENTILATOR

Models: **WGERV-A3B, -C3B**
WGERV-A5B, -C5B

General Notes

- Revised and/or additional pages may be issued from time to time.
- A complete and current manual consists of pages shown in the following contents section.

Important

- Contact the installing and/or local Bard distributor for all parts requirements. Make sure you have the complete model and serial number available from the unit rating plates.

Contents

Description	Page
Cabinet Components Intake	
♦ Exploded View	2
♦ Usage List	3
Cabinet Components Exhaust	
♦ Exploded View	4
♦ Usage List	4
Blower Components	
♦ Exploded View	5
♦ Usage List	5
Cassette Components	
♦ Exploded View	6
♦ Usage List	6
Control Panel Components	
♦ Exploded View	7
♦ Usage List	7
Rain Hood & Door Components	
♦ Exploded View	8
♦ Usage List	8



Bard Manufacturing Company, Inc.
Bryan, Ohio 43506
Since 1914...Moving ahead, just as planned.

Manual: 2110-1115
Supersedes: **NEW**
File: Tab 19
Date: 03-08-10

CABINET COMPONENTS

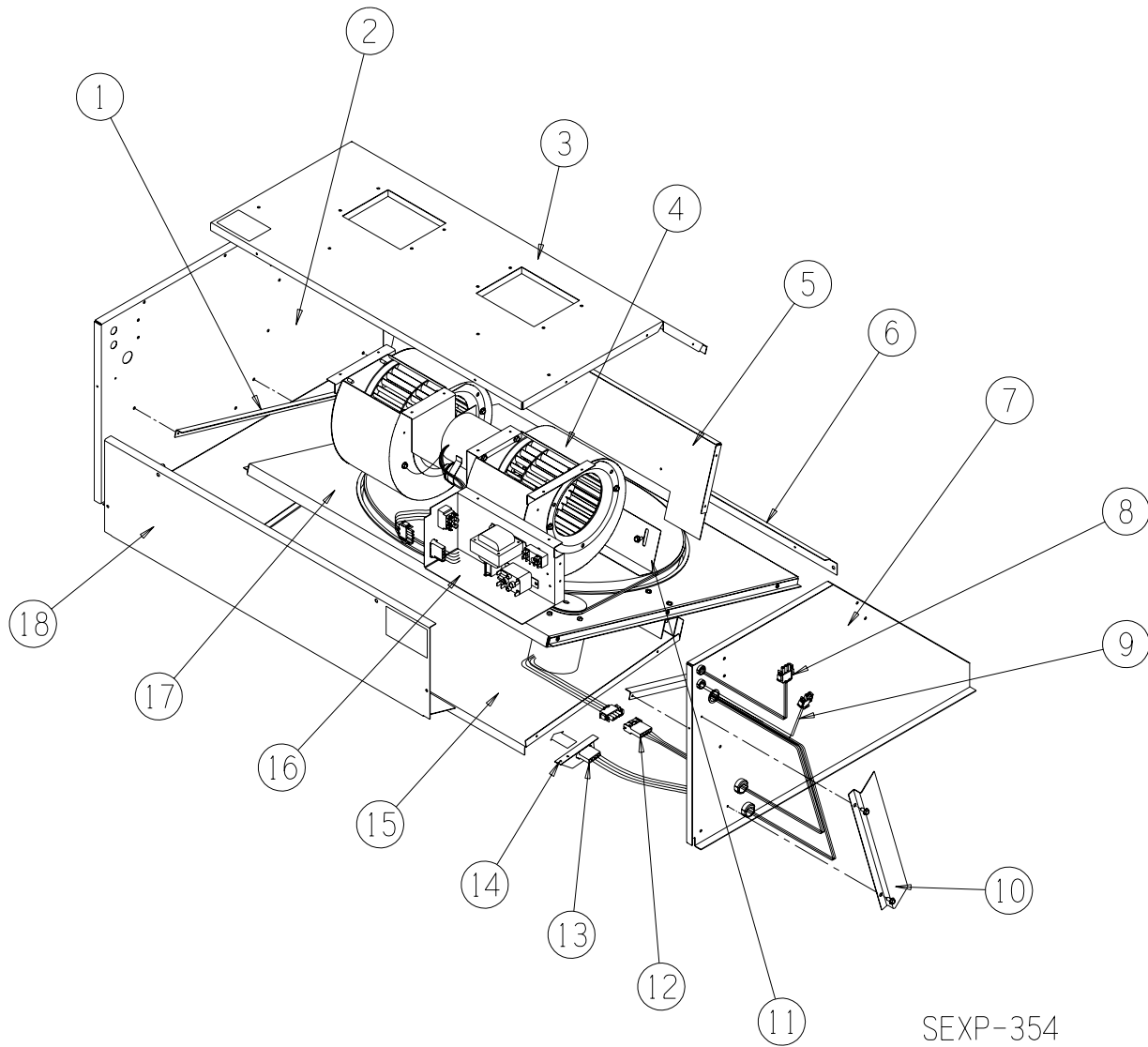

SEXP-354

CABINET COMPONENTS

Drawing No.	Part No.	Description	WGERV-A3B	WGERV-C3B	WGERV-A5B	WGERV-C5B
1	105Y1117	Left Side Angle	X	X		
1	105Y1085	Left Side Angle			X	X
2	S101Y400	Left Side	X	X		
2	S101Y379	Left Side			X	X
3	S107-228	Top	X	X		
3	S107-220	Top			X	X
4	Blower Assembly	See Blower Assembly Drawing	X	X	X	X
5	S121-357	Vertical Partition	X	X		
5	S121-344	Vertical Partition			X	X
6	105-1118	Cassette Stop Angle	X	X		
6	105-1083	Cassette Stop Angle			X	X
7	S101X400	Right Side	X	X		
7	S101X379	Right Side			X	X
8	3000-1128	Wire Assembly	X	X	X	X
9	3000-1130	Wire Assembly	X	X	X	X
10	105X1117	Right Side Angle	X	X		
10	105X1085	Right Side Angle			X	X
11	S105-1119	Pile Seal Assembly	X	X		
11	S105-1089	Pile Seal Assembly			X	X
12	3000-1125	Wire Assembly	X		X	
12	3000-1131	Wire Assembly		X		X
13	3000-1126	Wire Assembly	X	X	X	X
14	113-273	Plug Bracket	X	X	X	X
15	S127-319	Base	X	X		
15	S127-304	Base			X	X
16	Control Panel	See Control Panel Drawing	X	X	X	X
17	5070-040	Cassette Assembly Complete				
17	5070-029	Cassette Assembly Complete				
18	115-136	Front	X	X		
18	115-132	Front			X	X

CABINET COMPONENTS

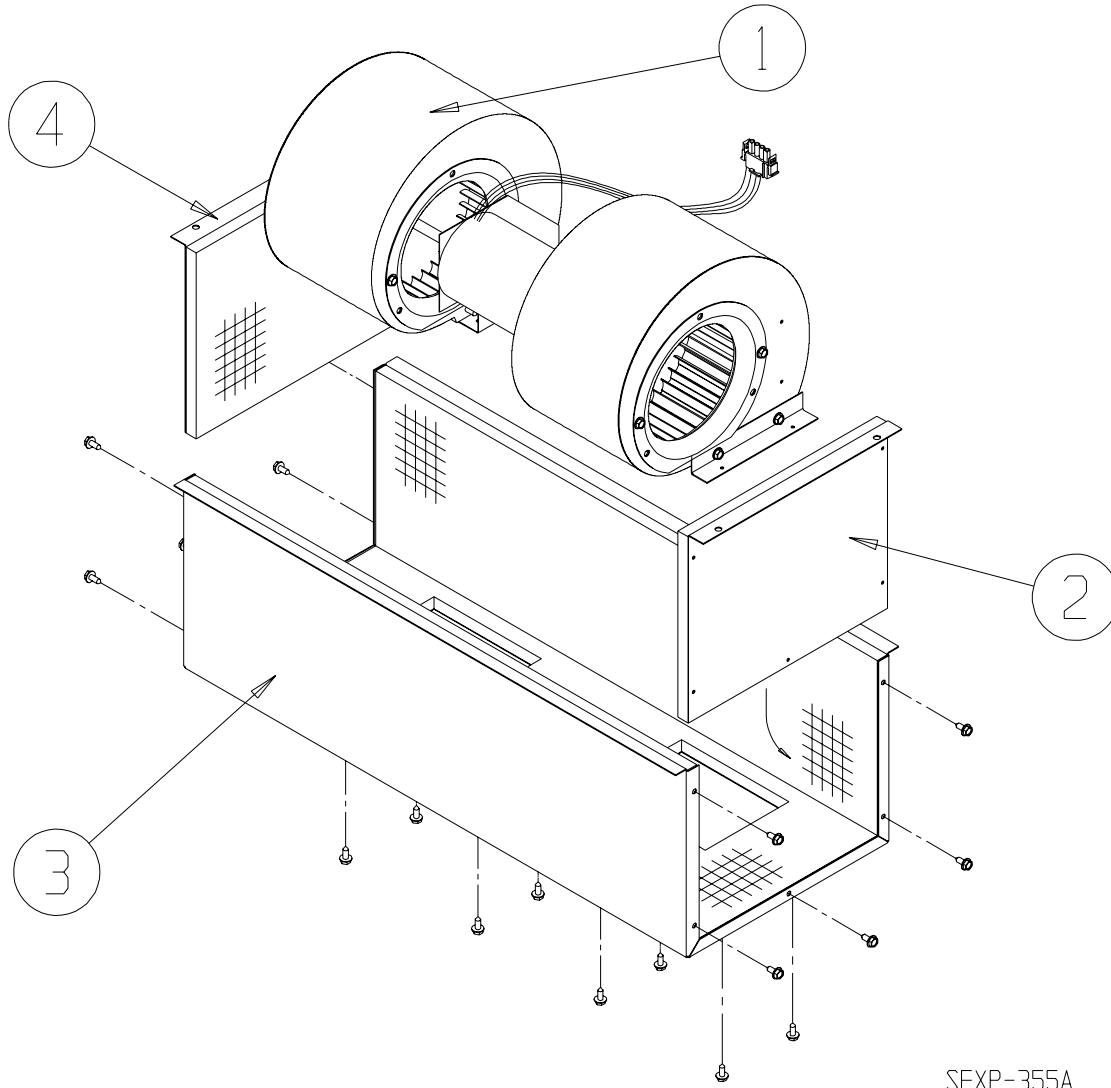

SEXP-355A

Drawing No.	Part No.	Description	WGERV-A3B	WGERV-C3B	WGERV-A5B	WGERV-C5B
1	Blower Assembly	See Blower Assembly Drawing	X	X	X	X
2	501X584	Right Blower Box Side	1	1	1	1
3	539-229	Blower Box Wrapper	X	X	X	X
4	501Y584	Left Blower Box Side	1	1	1	1

BLOWER COMPONENTS

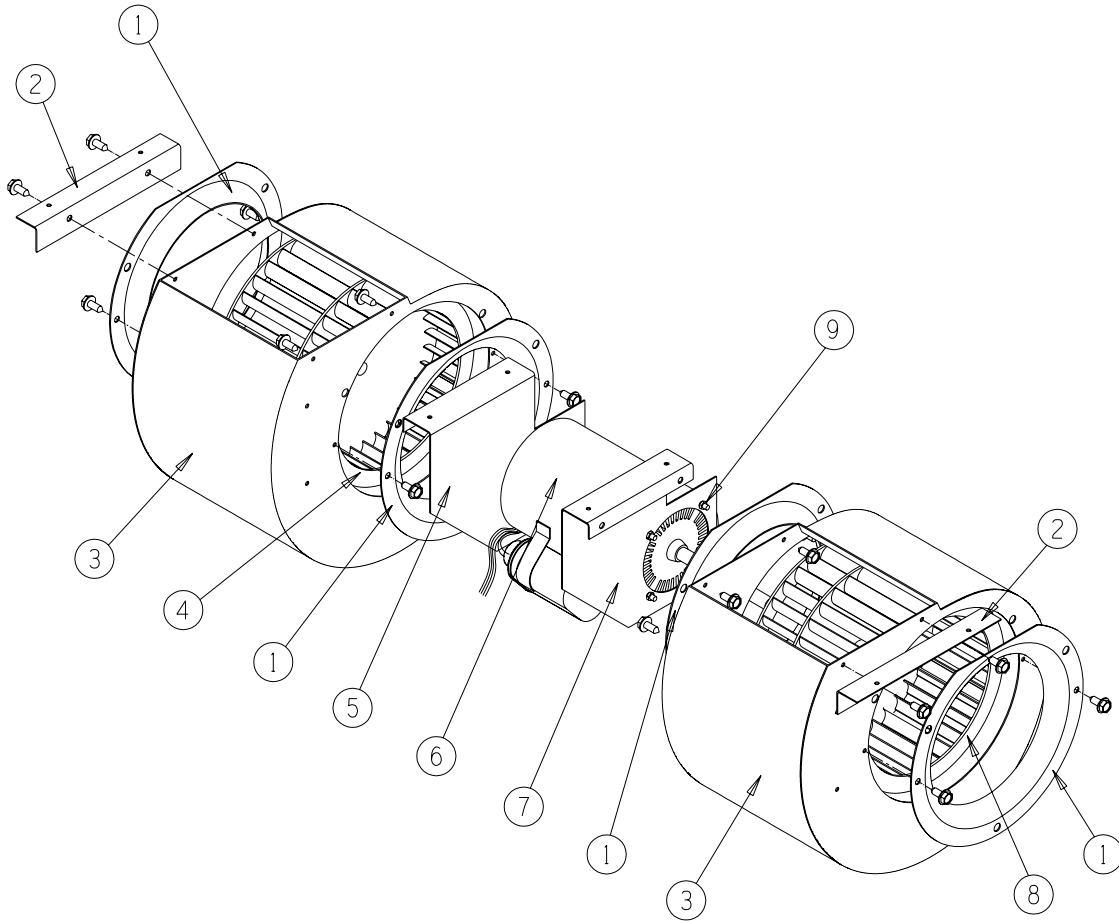

SEXP-356

Drawing No.	Part No.	Description	WGERV-A3B	WGERV-C3B	WGERV-A5B	WGERV-C5B
1	144-180	Inlet Plate	4	4	4	4
2	105-1084	Blower Side Angle	2	2	2	2
3	151-161	Blower Housing Assembly	2	2	2	2
4	5152-094	Blower Wheel CCW	X	X	X	X
5	113Y274	Left Blower Motor Support	X	X	X	X
6	8101-019	Motor 230V	X		X	
6	8101-022	Motor 460V		X		X
7	113X274	Right Blower Motor Support	X	X	X	X
8	5152-095	Blower Wheel CW	X	X	X	X
9	1012-200	Flange Nuts	8	8	8	8

CASSETTE COMPONENTS

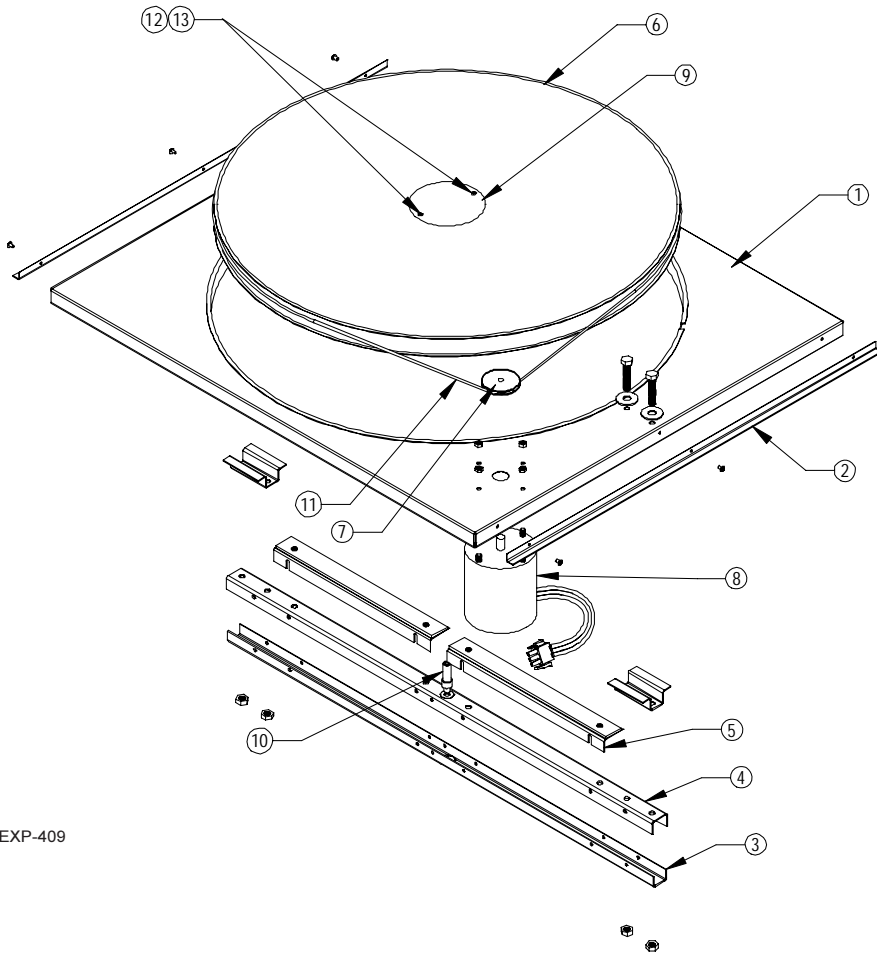

SEXP-409

Drawing No.	Part No.	Description	WGERV-A3B	WGERV-C3B	WGERV-A5B	WGERV-C5B
	5070-040	Complete Cassette with Motor and Wheels	X	X		
	5070-029	Complete Cassette with Motor and Wheels			X	X
1	139-174	Cassette Plate Assembly	X	X		
1	139-173	Cassette Plate Assembly			X	X
2	105-1082	Side Angle			X	X
3	140-300	Support Bar – Inner	X	X		
3	140-297	Support Bar – Inner			X	X
4	140-299	Support Bar – Outer	X	X		
4	140-296	Support Bar – Outer			X	X
5	104-1139	Pile Seal Angle	2	2	2	2
6	5070-046	Cassette Wheel	X	X		
6	5070-045	Cassette Wheel			X	X
7	5501-018	Pulley	X	X	X	X
8	8101-021	Motor	X	X	X	X
9	142-104	Hub Cover	X	X	X	X
10	1912-012	Wheel Shaft	X	X		
10	1912-011	Wheel Shaft			X	X
11	5070-030	Drive Belt	X	X	X	X
12	1012-164	Machine Screw			2	2
12	1012-165	Machine Screw	2	2		
13	8611-111	Nylon Spacer	8	8	2	2

CONTROL PANEL COMPONENTS

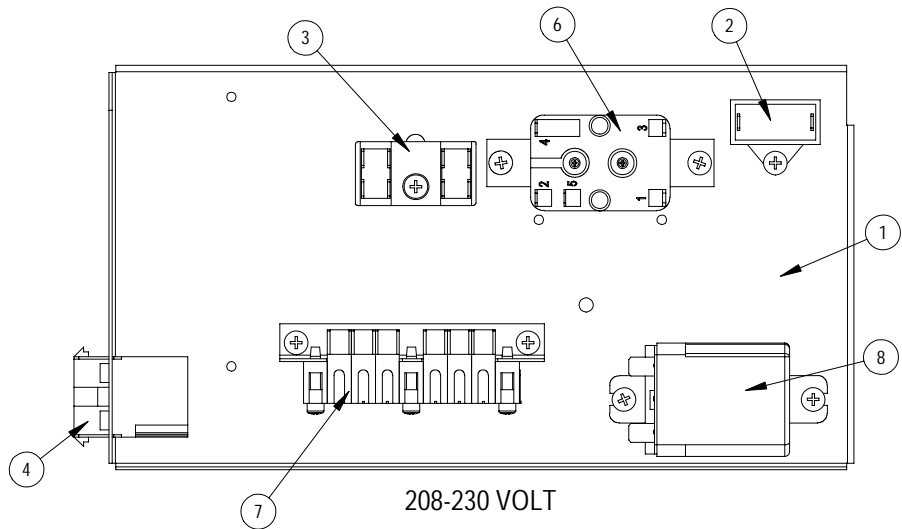
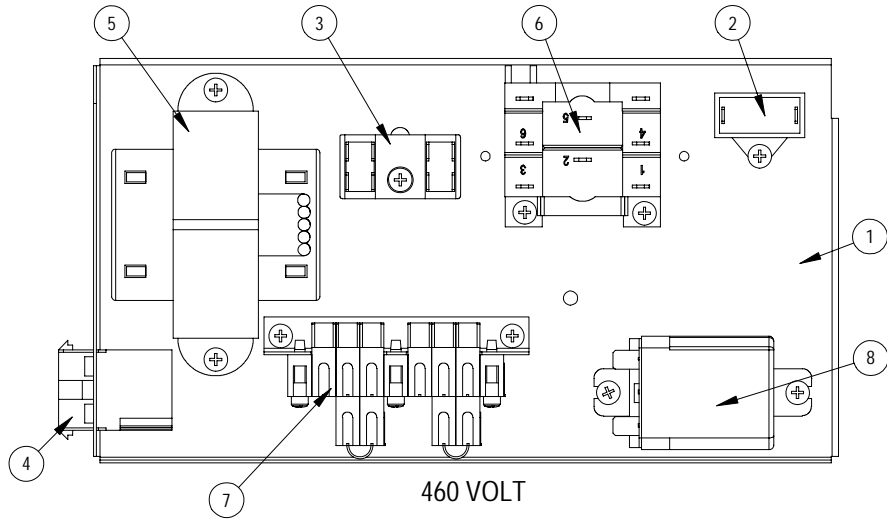

SEXP-569

Drawing No.	Part No.	Description	WGERV-C3B	WGERV-C5B	WGERV-A3B	WGERV-A5B
1	117-294	Control Panel	X	X	X	X
2	8552-073	Capacitor	X	X	X	X
3	8607-017	Terminal Block	X	X	X	X
4	3000-1341	Wire Assembly	X	X	X	X
5	8407-051	Transformer	X	X		
6	8201-009	Relay			X	X
6	8201-032	Relay	X	X		
7	S910-1761	Terminal Block Assembly			X	X
7	S910-1762	Terminal Block Assembly	X	X		
8	8201-071	Relay	X	X	X	X

RAIN HOOD AND DOOR COMPONENTS

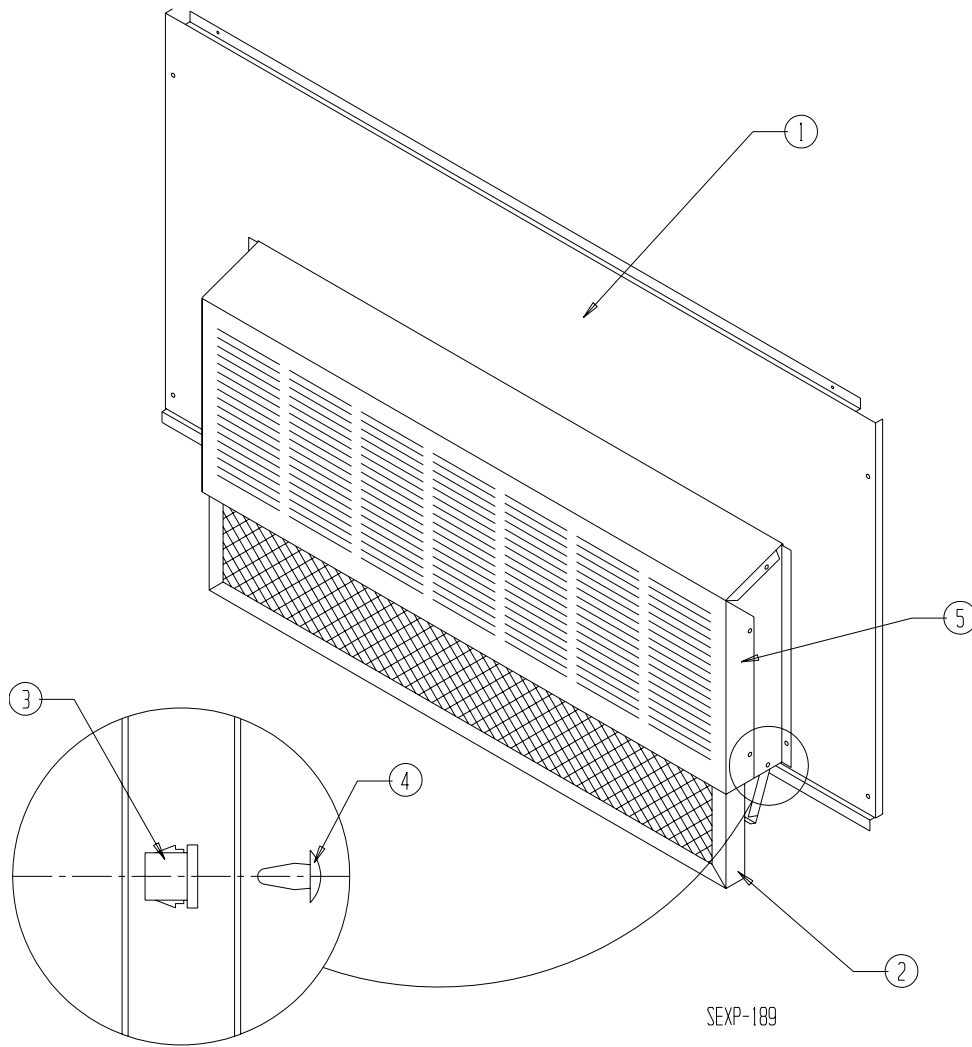

Drawing No.	Part No.	Description	WGERV-A3B	WGERV-C3B	WGERV-A5B	WGERV-C5B
1	553-348-*	Service Door	X	X		
1	553-329-*	Service Door			X	X
2	7003-059	Mist Eliminator	X	X		
2	7003-033	Mist Eliminator			X	X
3	8611-057	Bushing	2	2	2	2
4	8611-059	Canoe Clip	2	2	2	2
5	962167	Beige Rain Hood - Complete	X	X		
5	962168	Gray Rain Hood - Complete	X	X		
5	962116	Beige Rain Hood - Complete			X	X
5	962117	Gray Rain Hood - Complete			X	X

* Exterior cabinet parts are manufactured with various paint color options. To ensure that you receive the proper paint color, you must include the complete model and serial number of the unit for which cabinet parts are being ordered.