

---

# REPLACEMENT PARTS MANUAL

---

## WALL MOUNT ENERGY RECOVERY VENTILATOR

Models:

WERVPA5 WERVPC5

---

### General Notes

- Revised and/or additional pages may be issued from time to time.
- A complete and current manual consists of pages shown in the following contents section.

### Important

- Contact the installing and/or local Bard distributor for all parts requirements. Make sure to have the complete model and serial number available from the unit rating plates.

### Contents

<u>Description</u>	<u>Page</u>
Functional and Cabinet Components	
♦ Exploded View .....	2
♦ Usage List .....	3
Cassette Components	
♦ Exploded View .....	4
♦ Usage List .....	5
Rain Hood and Service Door	
♦ Exploded View .....	6
♦ Usage List .....	7
Control Panel	
♦ Layout View .....	8
♦ Usage List .....	8
Blower Assembly	
♦ Exploded View .....	9
♦ Usage List .....	9



Bard Manufacturing Company, Inc.  
Bryan, Ohio 43506  
www.bardhvac.com

Manual: 2110-1124A  
Supersedes: 2110-1124  
Date: 2-23-18

# FUNCTIONAL AND CABINET COMPONENTS

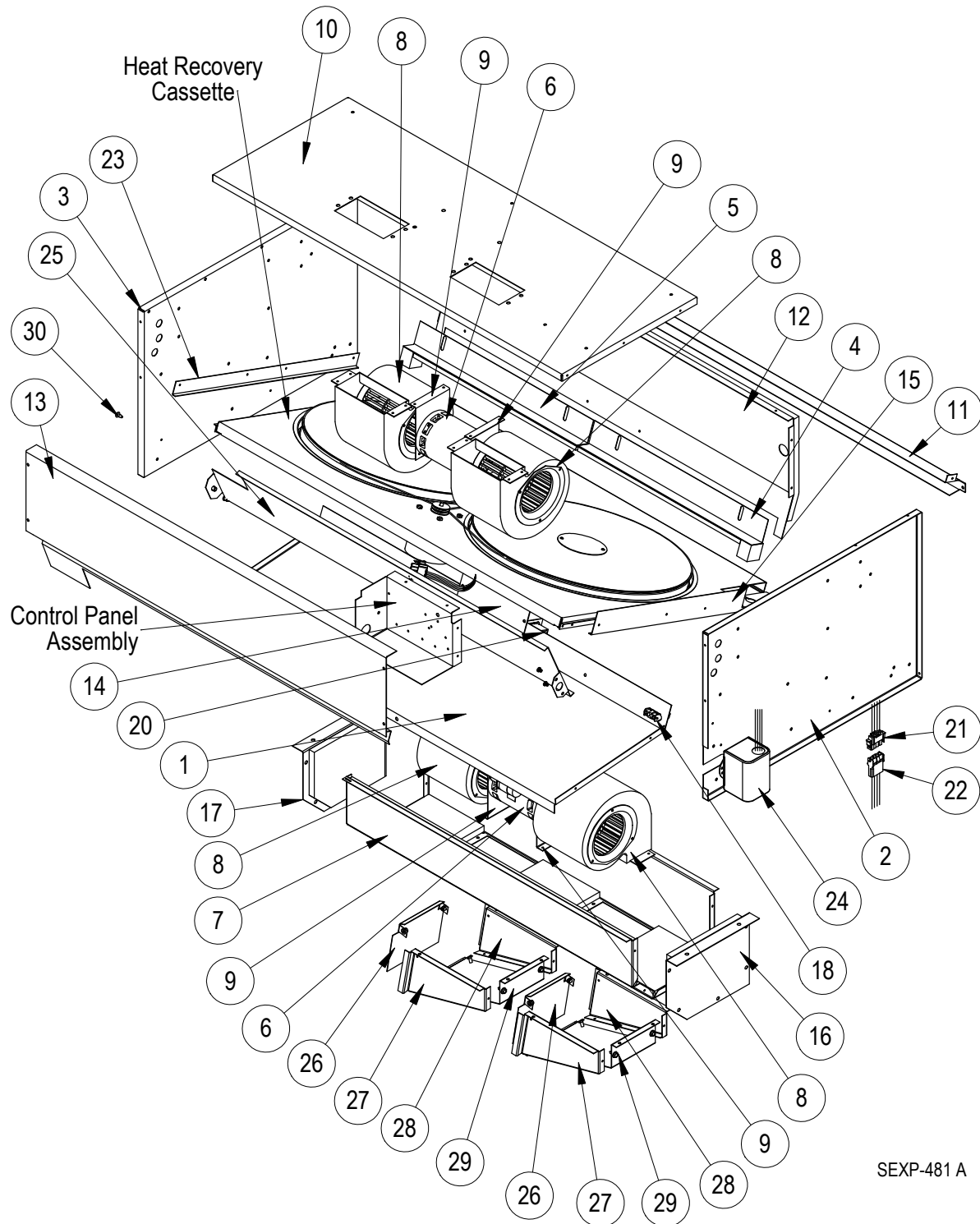

SEXP-481 A

# FUNCTIONAL AND CABINET COMPONENTS

Drawing No.	Part No.	Description	WERVPA5	WERVPC5
1	S526-278	Base Assembly	X	X
1	S527-506 ①	Base Assembly	X	X
2	S501-489	Right End Assembly	X	X
2	S501-904 ①	Right End Assembly	X	X
3	S501-490	Left End Assembly	X	X
3	S501-905 ①	Left End Assembly	X	X
4	105-914	Right Adjustment Angle with Seal	X	X
5	105-915	Left Adjustment Angle with Seal	X	X
6	8101-024	Blower Motor	2	
6	8101-025	Blower Motor		2
7	S538-200	Wrapper Assembly	X	X
7	S538-338 ①	Wrapper Assembly	X	X
8	Blower Housing and Wheel	See Blower Housing Assembly Drawing	X	X
9	128-018	Blower Motor Mount	4	4
10	S506-149	Top Assembly	X	X
10	S506-362 ①	Top Assembly	X	X
11	S508-103	Back Assembly	X	X
11	S508-335 ①	Back Assembly	X	X
12	S520-259	Middle Partition Assembly	X	X
12	S520-526 ①	Middle Partition Assembly	X	X
13	S115-151	Front Assembly	X	X
14	S536-260	Fill Plate Assembly	X	X
14	S536-776 ①	Fill Plate Assembly	X	X
15	104-911	Right Side Angle	X	X
16	S500X278	Left Wrapper End	X	X
16	S500-906 ①	Left Wrapper End	X	X
17	S500Y278	Right Wrapper End	X	X
17	S500-907 ①	Right Wrapper End	X	X
18	3000-1002	Wire Harness – Cassette	X	X
20	3000-1240	Wire Harness – Motor		X
20	3000-1241	Wire Harness – Motor	X	
21	3000-1535	Wire Harness – Unit	X	X
22	3000-1003	Wire Harness – CHCRV	X	X
23	104-912	Left Side Angle	X	X
24	8110-002	Damper Motor	X	X
25	S538-198	Damper Blade Assembly	2	2
25	S538-339 ①	Damper Blade Assembly	2	2
26	S138-203	Exhaust Damper Blade Assembly	2	2
27	S538Y201	Left Air Deflector Side Assembly	2	2
28	S538X201	Right Air Deflector Side Assembly	2	2
29	S539-202	Exhaust Air Deflector Top Assembly	2	2
30	8611-059	Canoe Clip	X	X
NS	4056-232	Wiring Diagram	X	
NS	4056-315	Wiring Diagram		X

NS = Not Shown

① Nonfiberglass insulation option

# CASSETTE COMPONENTS

---

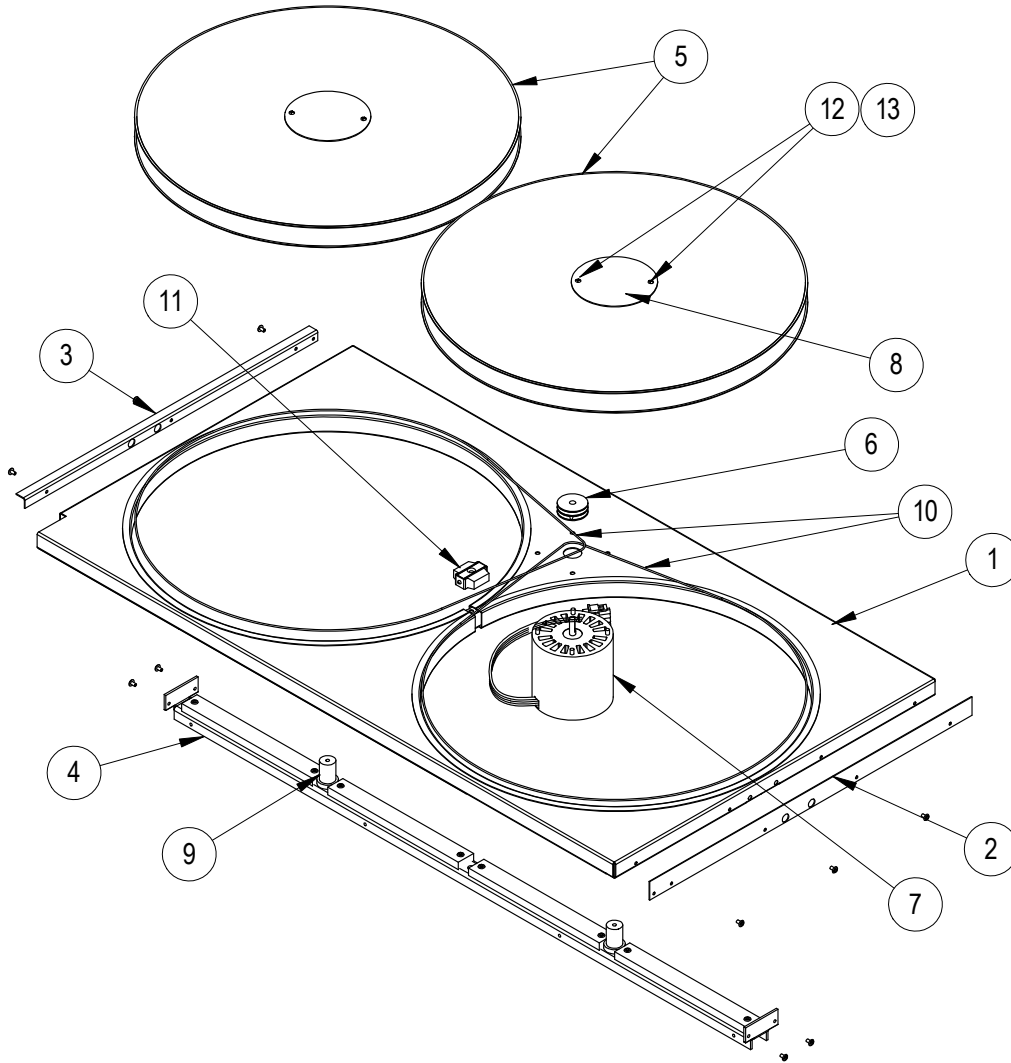

SEXP-472

# CASSETTE COMPONENTS

Drawing No.	Part No.	Description	WERVPA5
			WERVPC5
	5070-035	Complete Cassette with Motor and Wheels	X
	5070-058 ①	Complete Cassette with Motor and Wheels	X
1	139-170	Cassette Plate Assembly	X
2	104-1129	Right Support Angle	X
3	104-1130	Left Support Angle	X
4	S140-314	Support Bar Assembly	X
5	5070-043	Cassette Wheel	2
6	5501-020	Pulley	X
7	8101-016	Motor	X
8	142-104	Hub Cover	2
9	1912-012	Wheel Shaft	2
10	8620-196	Drive Belt and Pulley Assembly	X
11	S5070-047	Center Block Assembly	X
12	1012-164	Machine Screw	4
13	8611-111	Nylon Spacer	4
NS	5070-052	Bearing/Hub Assembly	2
NS	8620-204 ②	Bearing/Hub, Shaft and Hardware Kit	2
NS	8620-205 ③	Shaft and Hardware Kit	2

NS = Not Shown

① = Nonfiberglass insulation option

② = Contains Item #'s 8, 9, 12, 13 and "NS" Bearing + Additional Hardware

③ = Contains Item #'s 8, 9, 12, 13 + Additional Hardware

# RAIN HOOD AND SERVICE DOOR

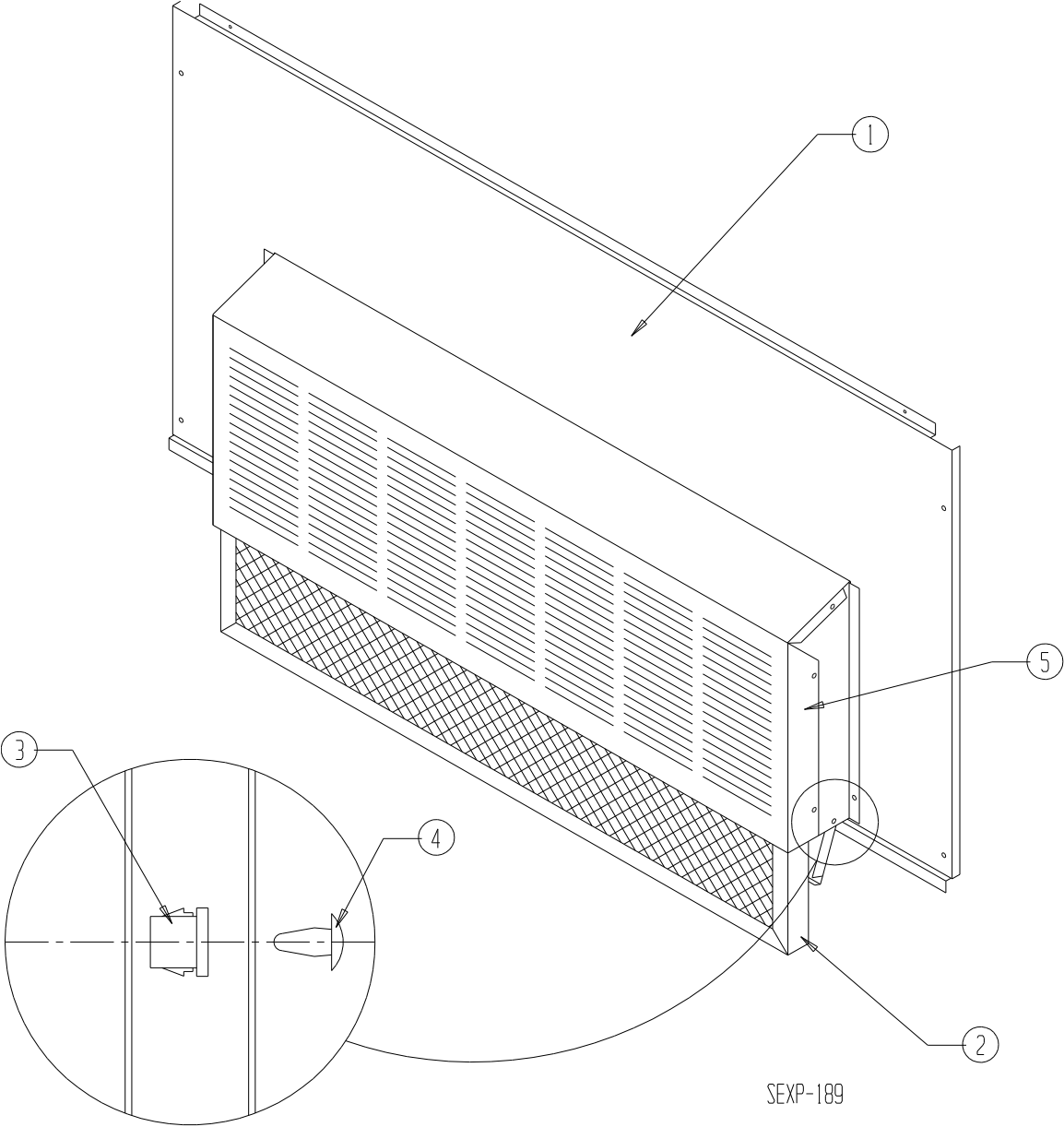

## RAIN HOOD AND SERVICE DOOR

---

Drawing No.	Part No.	Description	WERVPA5	WERVPC5
1	553-408-*	Service Door		
1	S553-644 ①	Service Door	X	
2	7003-061	Mist Eliminator	X	
3	8611-057	Bushing		2
4	8611-059	Canoe Clip		2
5	920-0033	Beige Rain Hood Complete with Mist Eliminator	X	
5	920-0036	Dark Bronze Rain Hood Complete with Mist Eliminator	X	
5	920-0035	Desert Brown Rain Hood Complete with Mist Eliminator	X	
5	920-0034	Buckeye Gray Rain Hood Complete with Mist Eliminator	X	

\* Exterior cabinet parts are manufactured with various color options. To insure the proper color is received, include the complete model and serial number of the unit for which parts are being ordered.

① Nonfiberglass insulation option

# CONTROL PANEL

Drawing No.	Part No.	Description	WERVPA5 WERVPC5
1	116-266	Control Panel	X
2	8552-100	Cassette Motor Capacitor	X
3	8201-086	Blower Relay	X
4	8407-043	Transformer	X
5	8607-017	Terminal Block	X
6	910-1672	Terminal Block Assembly	X
NS	3000-1518	12-Pin Vent Plug (Low Voltage)	X
NS	3000-1522	12-Pin Vent Plug Ext. Harness (LH installations)	X

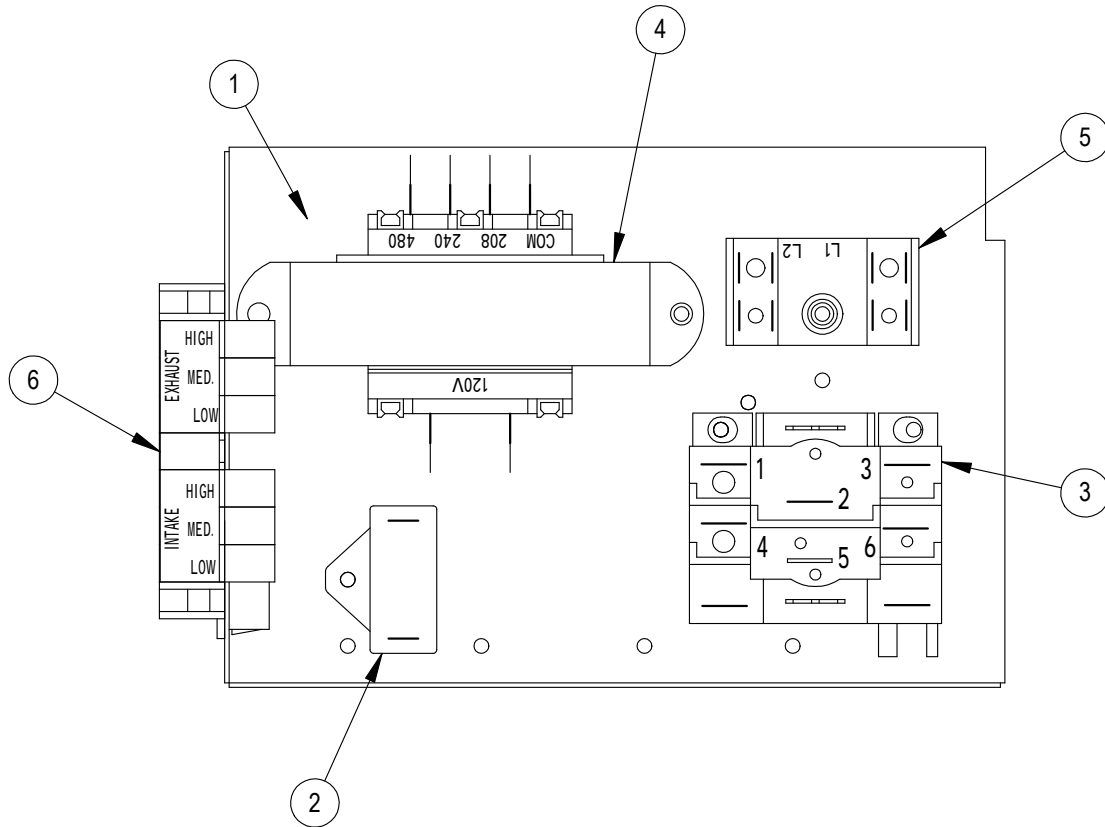

SEXP-487



# BLOWER ASSEMBLY

Drawing No.	Part No.	Description	All Models
1	5152-078	Blower Wheel	1
2	144-188	Inlet Ring	2
3	151-119	Blower Housing	1

