REPLACEMENT PARTS MANUAL

ECONOMIZER

Models:

WECOPT2 WECOPE2
WECOPT3 WECOPE3
WECOPT5 WECOPE5

General Notes

- Revised and/or additional pages may be issued from time to time.
- A complete and current manual consists of pages shown in the following contents section.

Important

- Contact the installing and/or local Bard distributor for all parts requirements. Make sure to have the complete model and serial number available from the unit rating plates.

Contents

<u>Description</u>	<u>Page</u>
WECOPT2, WECOPE2, WECOPT3, WECOPE3	
♦ Exploded View	2
♦ Usage List	3
WECOPT5, WECOPE5	
♦ Exploded View	4
♦ Usage List	5
Control Panel Assembly	
♦ Layout View	6
♦ Usage List	7
Actuator Assembly	
♦ Layout View	8
♦ Usage List	9
Economizer Air Hood	
♦ Exploded View	10
♦ Usage List	11
♦ Usage List	12



Bard Manufacturing Company, Inc.
Bryan, Ohio 43506
www.bardhvac.com

Manual: 2110-1126
Supersedes: **NEW**
Date: 4-4-16

WECOPT2, WECOPE2, WECOPT3, WECOPE3

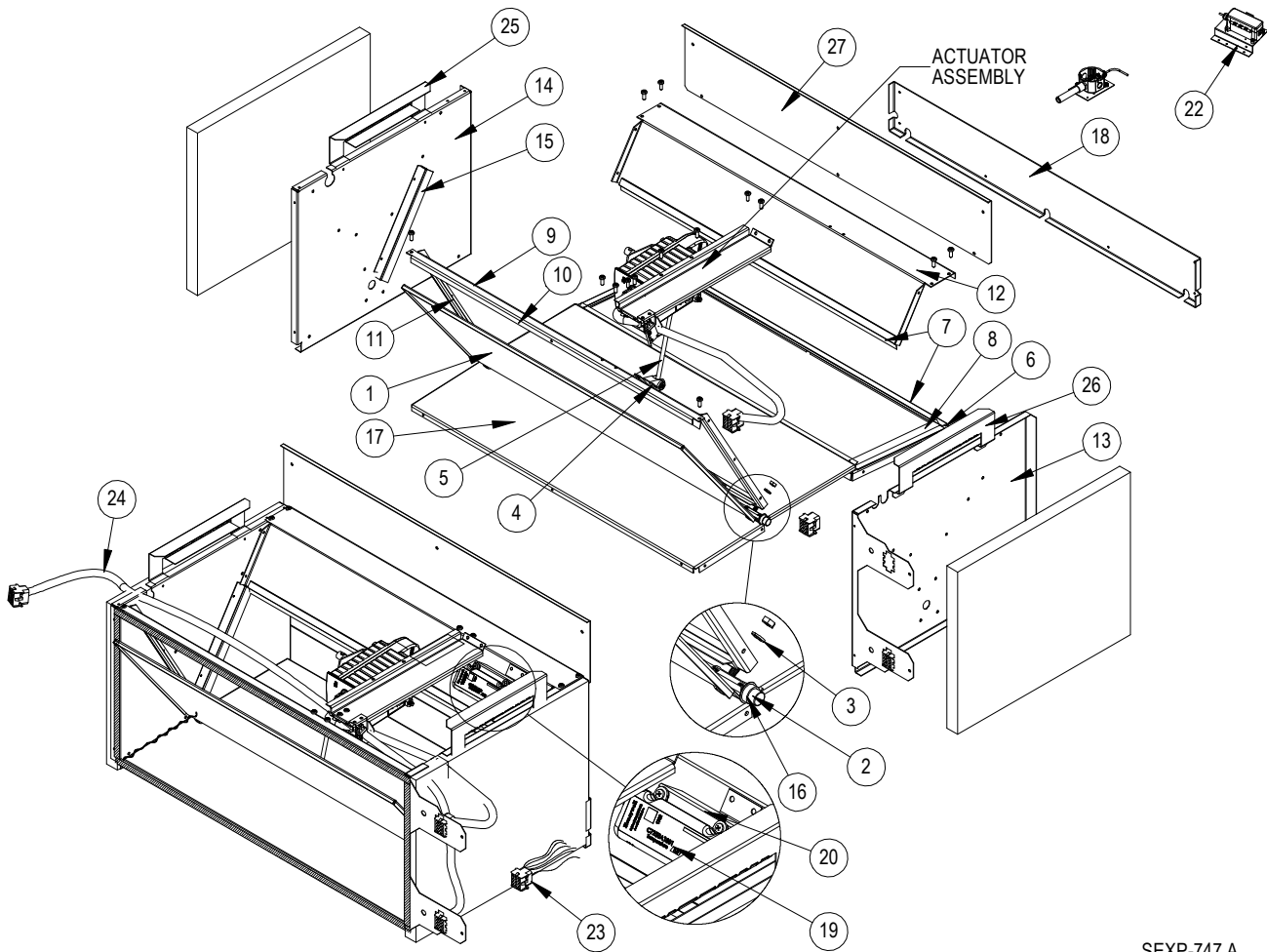

SEXP-747 A

WECOPT2, WECOPE2, WECOPT3, WECOPE3

Drawing No.	Part No.	Description	WECOPT2	WECOPE2	WECOPT3	WECOPE3
1	S139-325	Blade Assembly	X	X		
1	S139-324	Blade Assembly			X	X
2	8602-038	DBP-1 Damper Pin with Bolt, Washer and Nut	2	2	2	2
3	1012-126	1/4" Type "A" Washer	2	2	2	2
4	8602-040	BKP-24 Bracket with Rod Connector and Set Screw	X	X	X	X
5	8602-044	1/4" x 7-1/2" Rod	X	X	X	X
6	137-744	Lower Rear Partition	X	X		
6	137-740	Lower Rear Partition			X	X
7	S1921-067-2010	Damper Blade Seal	3	3		
7	S1921-067-2510	Damper Blade Seal			3	3
8	S1921-067-0802	Damper Blade Seal	2	2	2	2
9	137-741	Upper Front Partition	X	X		
9	137-737	Upper Front Partition			X	X
10	S1921-067-2006	Damper Blade Seal	2	2		
10	S1921-067-2506	Damper Blade Seal			2	2
11	S1921-067-1004	Damper Blade Seal	2	2	2	2
12	137-743	Upper Rear Partition	X	X		
12	137-739	Upper Rear Partition			X	X
13	S101-903	Right Side Assembly, Insulated	X	X	X	X
14	S101Y869	Left Side Assembly, Insulated	X	X	X	X
15	S1921-067-0800	Damper Blade Seal	2	2	2	2
16	8602-052	1/2" I.D. Bronze Bushing	2	2	2	2
17	137-742	Lower Front Partition	X	X		
17	137-738	Lower Front Partition			X	X
18	137-747	Lower Rear Fill	2	2		
18	137-745	Lower Rear Fill			2	2
19	8602-058	Mixed Air Temperature Sensor, 20K	X	X	X	X
20	113-433	Sensor Bracket	X	X	X	X
21	910-1898	Outdoor Temperature Sensor Assembly	X		X	
22	910-1915	Outdoor Enthalpy Sensor Assembly		X		X
23	3000-1456	Wire Assembly, Connection to Unit Low Voltage	X	X	X	X
24	3000-1461	Wire Assembly, "L" Model Left Hand Units Only	X	X	X	X
25	113-542	Long Filter Bracket	X	X	X	X
26	113-543	Short Filter Bracket	X	X	X	X
27	137-748	Upper Rear Fill	X	X		
27	137-746	Upper Rear Fill			X	X
NS	S136-664	Condenser Cover Plate	X	X		
NS	S136-751	Condenser Cover Plate			X	X

NS – Not Shown

WECOPT5, WECOPE5

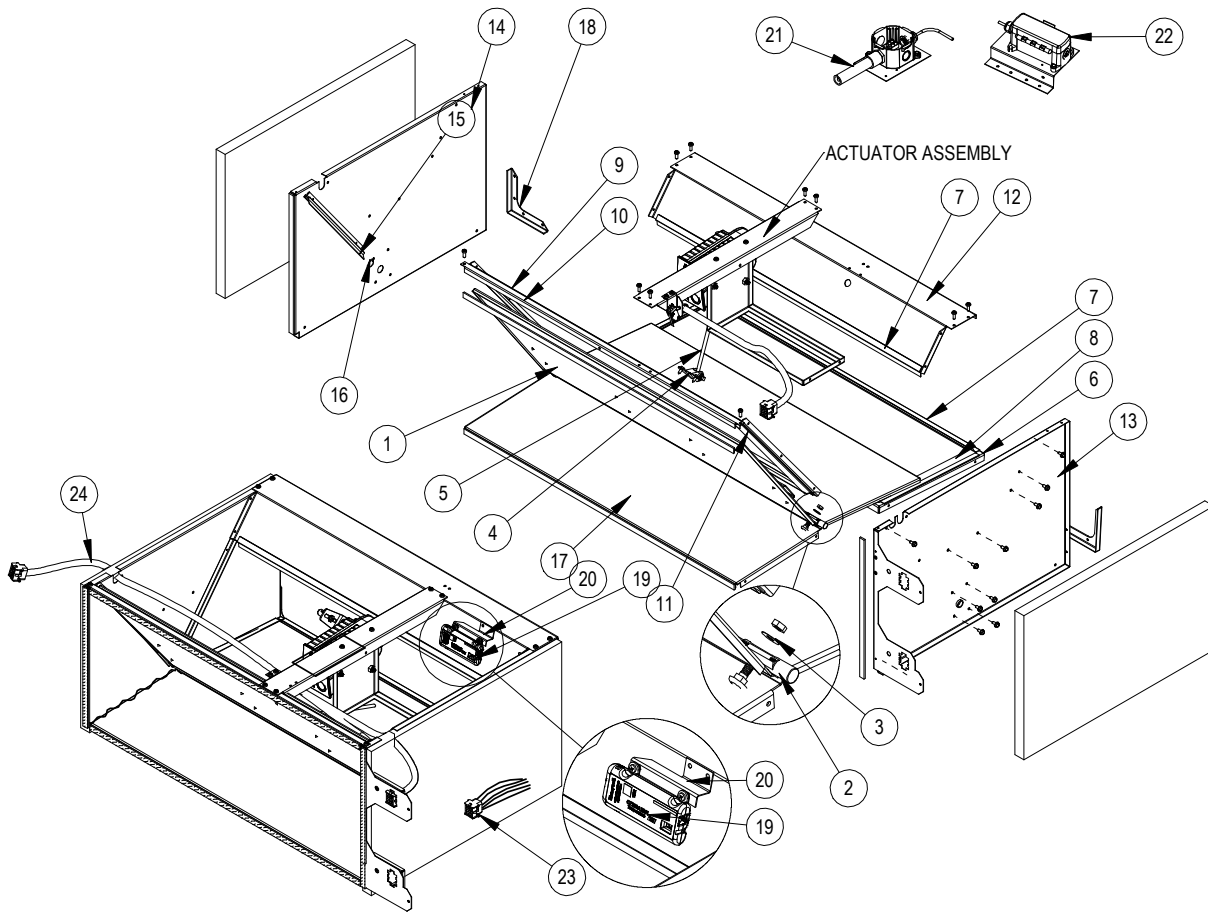

SEXP-746 A

WECOPT5, WECOPE5

Drawing No.	Part No.	Description	WECOPT5	WECOPE5
1	S139-323	Blade Assembly	X	X
2	8602-038	DBP-1 Damper Pin with Bolt, Washer and Nut	2	2
3	1012-126	1/4" Type "A" Washer	2	2
4	8602-040	BKP-24 Bracket	X	X
5	8602-077	1/4" x 9" Rod	X	X
6	137-736	Lower Rear Partition	X	X
7	S1921-067-2906	Damper Blade Seal	3	3
8	S1921-067-1011	Damper Blade Seal	2	2
9	137-733	Upper Front Partition	X	X
10	S1921-067-2909	Damper Blade Seal	2	2
11	S1921-067-1300	Damper Blade Seal	2	2
12	137-735	Upper Rear Partition	X	X
13	S101-894	Right Side Assembly, Insulated	X	X
14	S101Y852	Left Side Assembly, Insulated	X	X
15	S1921-067-1007	Damper Blade Seal	2	2
16	8602-052	1/2" I.D. Bronze Bushing	2	2
17	137-734	Lower Front Partition	X	X
18	113-526	Corner Bracket	2	2
19	8602-058	Mixed Air Temperature Sensor, 20K	X	X
20	113-433	Sensor Bracket	X	X
21	910-1898	Outdoor Temperature Sensor Assembly	X	
22	910-1915	Outdoor Enthalpy Sensor Assembly		X
23	3000-1456	Wire Assembly, Connection to Unit Low Voltage	X	X
24	3000-1461	Wire Assembly, "L" Model Left Hand Units Only	X	X
NS	S537-731	Condenser Cover Plate	X	X

NS – Not Shown

CONTROL PANEL ASSEMBLY

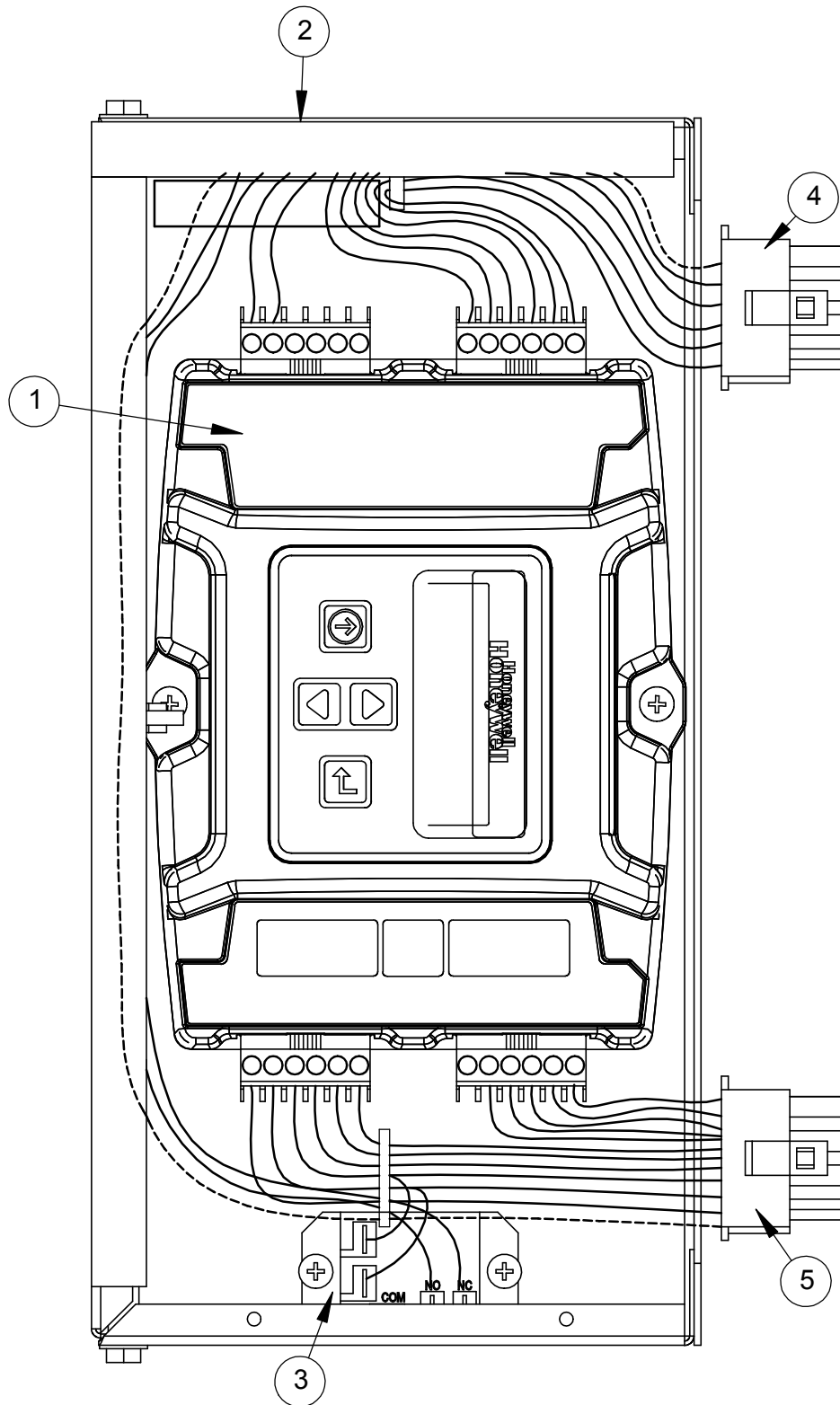

SEXP-749

CONTROL PANEL ASSEMBLY

Drawing No.	Part No.	Description	WECOPT2	WECOPE2	WECOPT3	WECOPE3	WECOPT5	WECOPE5
1	8602-056-0001	Programmed JADE Economizer Module	X	X	X			
1	8602-056-0003	Programmed JADE Economizer Module				X	X	X
2	117-354	Control Panel			X			
2	117-364	Control Panel	X	X		X	X	
3	8201-130	Relay, SPDT Pilot Duty	X	X	X	X	X	X
4	3000-1457	Wire Assembly	X	X	X			
4	3000-1477	Wire Assembly				X	X	X
5	3000-1455	Wire Assembly	X	X	X	X	X	X

ACTUATOR ASSEMBLY

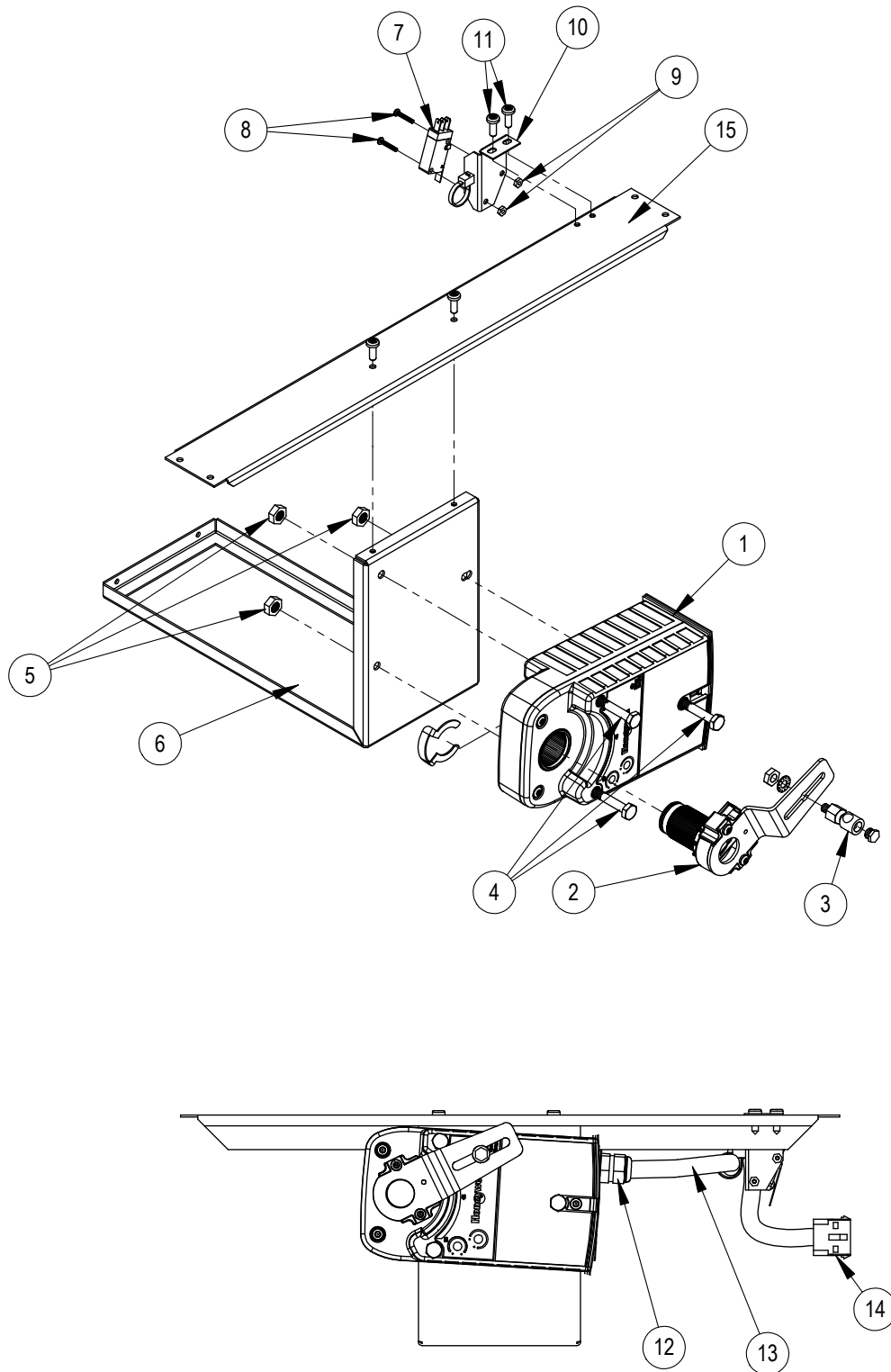

SEXP-748

ACTUATOR ASSEMBLY

Drawing No.	Part No.	Description	WECOP*2	WECOP*3	WECOP*5
1	8602-059	Direct Coupled Actuator - Sylk	X	X	X
2	8602-068	Crank Arm	X	X	X
3	8602-008	Ball Joint	X	X	X
4	1012-174	1/4" - 20, 3-1/4" Long Hex Cap Screw	3	3	3
5	1012-201	1/4" - 20, Steep Keps Hex Nut	3	3	3
6	141-428	Actuator Support Plate			X
6	141-434	Actuator Support Plate	X	X	
7	8406-138	Lever Switch SPDT Sealed Pilot	X	X	X
8	1012-178	4 - 40 x 5/8" Phillips Pan Head Screw	2	2	2
9	1012-231	4 - 40 Steel Hex Nut	2	2	2
10	113-525	Blade Switch Bracket	X	X	X
11	1012-128	10 - 16 x 5/8" Torx Head Screw	8	8	8
12	8611-130	LTF 7 Fitting 3/4" O.D.	X	X	X
13	8611-125-1800	18" of 1/2" Split Tubing	X	X	X
14	3000-1458	Wire Assembly			X
14	3000-1468	Wire Assembly	X	X	
15	141-427	Actuator Support Bar			X
15	141-431	Actuator Support Bar	X	X	

ECONOMIZER AIR HOOD

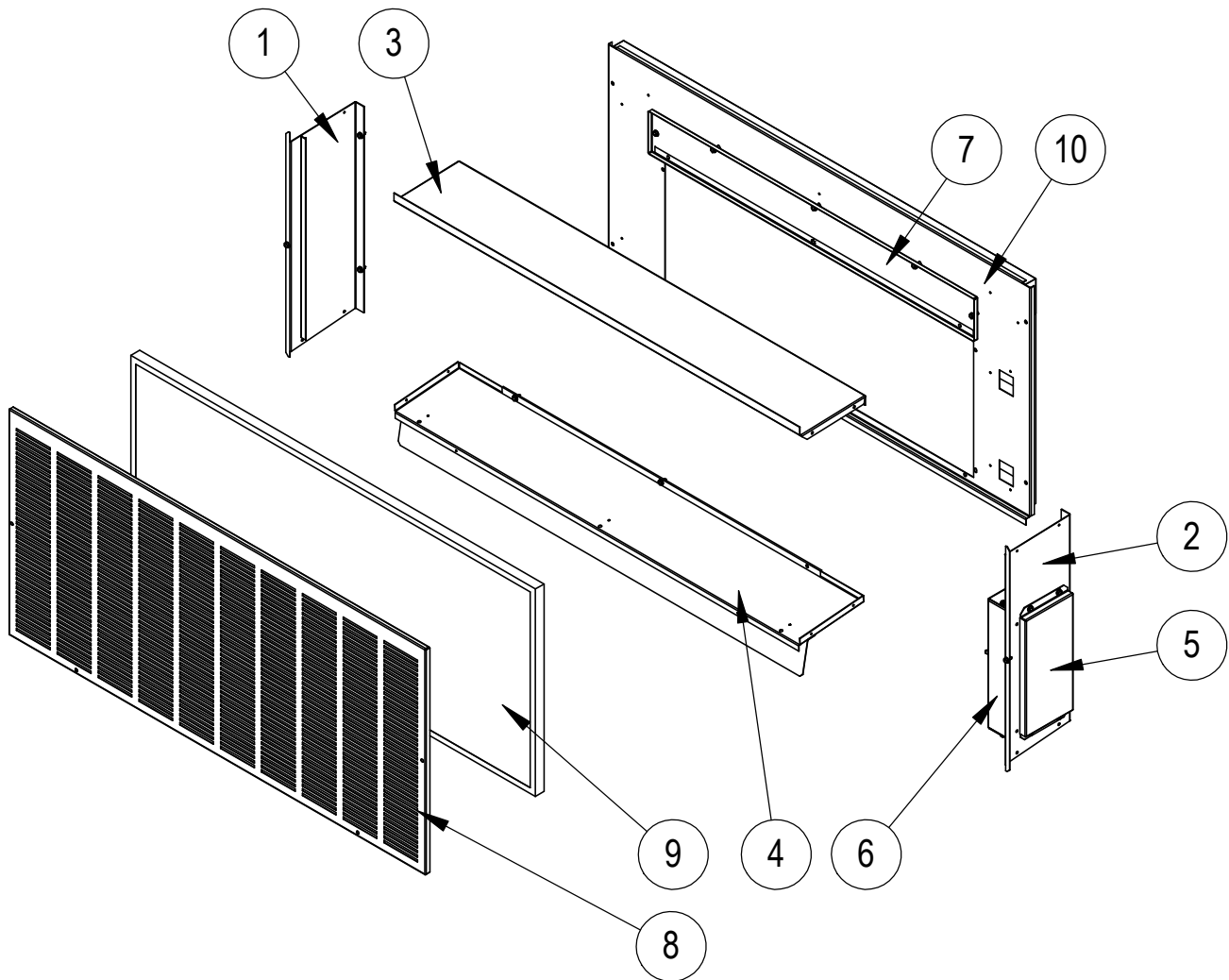

SEXP-758

This exploded view is referenced in tables on pages 11 and 12

ECONOMIZER AIR HOOD

Drawing No.	Part No.	Description	WECOP*2	WECOP*3	WECOP*5
1	S101-872-* ①	Right Side	X	X	
1	S101-883 ②	Right Side	X	X	
1	S101-881 ③	Right Side	X	X	
1	S101-859-* ①	Right Side			X
1	S101-876 ②	Right Side			X
1	S101-878 ③	Right Side			X
2	101-873-* ①	Left Side	X	X	
2	S101-884 ②	Left Side	X	X	
2	S101-882 ③	Left Side	X	X	
2	S101-860-* ①	Left Side			X
2	S101-877 ②	Left Side			X
2	S101-879 ③	Left Side			X
3	S107-345-* ①	Hood Top	X		
3	S107-355 ②	Hood Top	X		
3	S107-356 ③	Hood Top	X		
3	S107-346-* ①	Hood Top		X	
3	S107-354 ②	Hood Top		X	
3	S107-353 ③	Hood Top		X	
3	S107-344-* ①	Hood Top			X
3	S107-350 ②	Hood Top			X
3	S107-351 ③	Hood Top			X
4	S127-494-* ①	Hood Bottom	X		
4	S127-502 ②	Hood Bottom	X		
4	S127-503 ③	Hood Bottom	X		
4	S127-495-* ①	Hood Bottom		X	
4	S127-501 ②	Hood Bottom		X	
4	S127-500 ③	Hood Bottom		X	
4	S127-489-* ①	Hood Bottom			X
4	S127-498 ②	Hood Bottom			X
4	S127-499 ③	Hood Bottom			X
5	S133-262-* ①	Control Panel Cover	X	X	X
5	S133-269 ②	Control Panel Cover	X	X	X
5	S133-270 ③	Control Panel Cover	X	X	X
6	See page 6	Control Panel Assembly (JADE)	X	X	X
7	S553-613	Filter Door	X		
7	S553-634 ②	Filter Door	X		
7	S553-631 ③	Filter Door	X		
7	S553-611	Filter Door		X	
7	S553-632 ②	Filter Door		X	
7	S553-636 ③	Filter Door		X	
7	S553-641	Filter Door			X
7	S553-643 ②	Filter Door			X
7	S553-627 ③	Filter Door			X

Continued on page 12

- ① Exterior cabinet parts are manufactured with various paint color options. To ensure the proper paint color is received, include the complete model and serial number of the unit for which cabinet parts are being ordered.
- ② Exterior cabinet parts are manufactured from stainless steel Code "S"
- ③ Exterior cabinet parts are manufactured from aluminum Code "A"

ECONOMIZER AIR HOOD

Drawing No.	Part No.	Description	WECOP*2	WECOP*3	WECOP*5
<i>Continued from page 11</i>					
8	115-285-* ①	Hood Front	X		
8	115-292 ②	Hood Front	X		
8	115-293 ③	Hood Front	X		
8	115-284-* ①	Hood Front		X	
8	115-291 ②	Hood Front		X	
8	115-290 ③	Hood Front		X	
8	115-283-* ①	Hood Front			X
8	115-287 ②	Hood Front			X
8	115-288 ③	Hood Front			X
9	7003-067	Mist Filter (31" X 16" X 1")	X		
9	7003-066	Mist Filter (36" X 16" X 1")		X	
9	7003-062	Mist Filter (40" X 18" X 1")			X
10	S553-612-* ①	Hood Mounting Door	X		
10	S553-635 ②	Hood Mounting Door	X		
10	S553-630 ③	Hood Mounting Door	X		
10	S553-610-* ①	Hood Mounting Door		X	
10	S553-633 ②	Hood Mounting Door		X	
10	S553-637 ③	Hood Mounting Door		X	
10	S553-595-* ①	Hood Mounting Door			X
10	S553-626 ②	Hood Mounting Door			X
10	S553-627 ③	Hood Mounting Door			X

- ① Exterior cabinet parts are manufactured with various paint color options. To ensure the proper paint color is received, include the complete model and serial number of the unit for which cabinet parts are being ordered.
- ② Exterior cabinet parts are manufactured from stainless steel Code "S"
- ③ Exterior cabinet parts are manufactured from aluminum Code "A"