REPLACEMENT PARTS MANUAL

Economizer

Models:

ECON-NC2A ECON-WD2A ECON-DB2A
ECON-NC3A ECON-WD3A ECON-DB3A

General Notes

- Revised and/or additional pages may be issued from time to time.
- A complete and current manual consists of pages shown in the following contents section.

Important

- Contact the installing and/or local Bard distributor for all parts requirements. Make sure to have the complete model and serial number available from the unit rating plates.

Contents

Description	Page
Economizer	
♦ Exploded View	2
♦ Usage List	3
Economizer Air Hood	
♦ Exploded View	4
♦ Usage List	5
Blade Assembly	
♦ Layout View	6
♦ Usage List	6
Control Panel Assembly	
♦ Layout View	7
♦ Usage List	7
Actuator Assembly – ECON-NC	
♦ Exploded View	8
♦ Usage List	8
Actuator Assembly – ECON-WD/DB	
♦ Exploded View	9
♦ Usage List	9

BMC, Inc.
Bryan, Ohio 43506

Manual : 2110-1150
Supersedes: **NEW**
Date: 4-23-24

ECONOMIZER

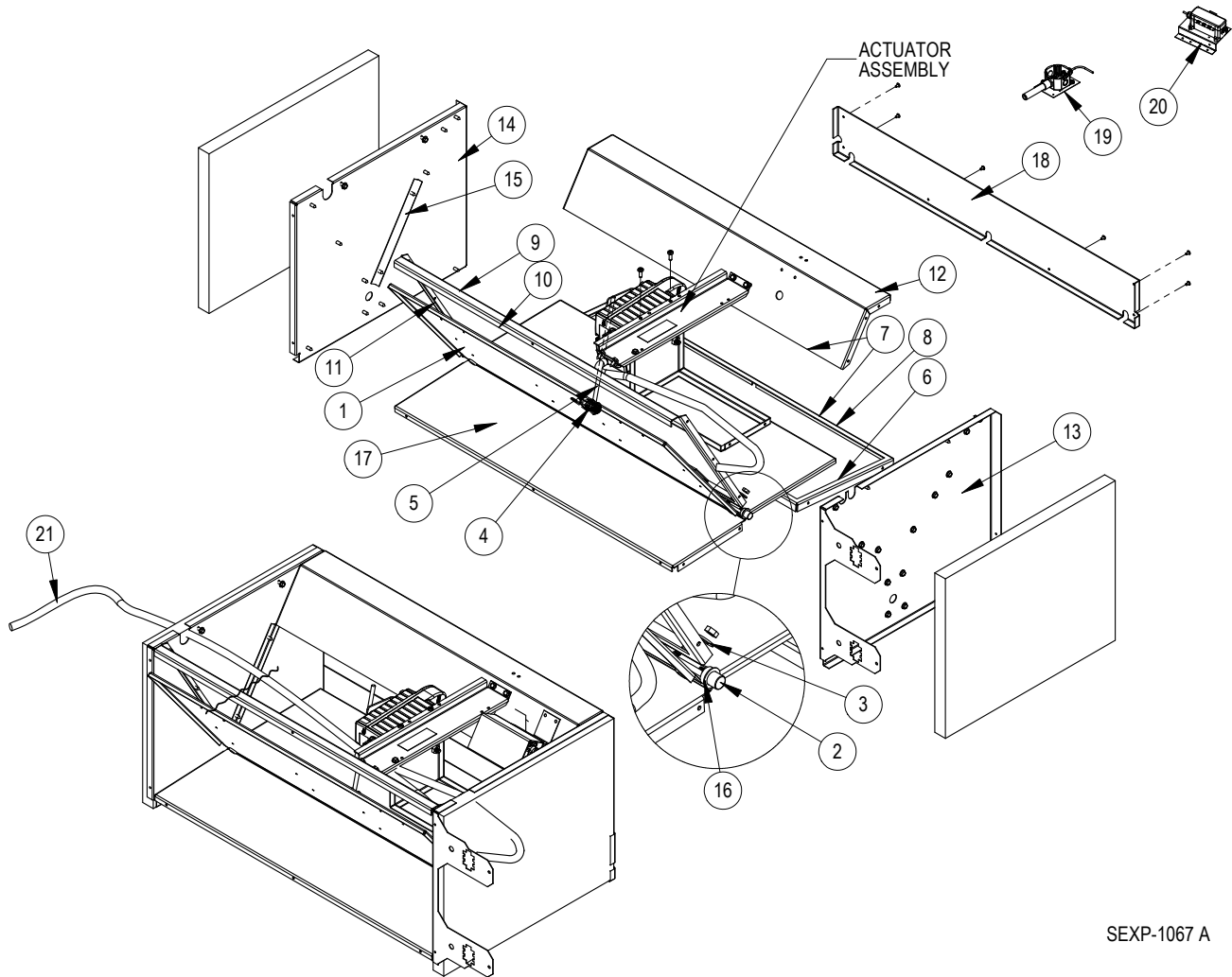

SEXP-1067 A

ECONOMIZER

Dwg. No.	Part No.	Description	ECON-NC2A	ECON-WD2A	ECON-DB2A	ECON-NC3A	ECON-WD3A	ECON-DB3A
1	139-394BX	Blade Assembly	X	X	X			
1	139-393BX	Blade Assembly				X	X	X
2	8602-038	DBP-1 Damper Pin with Bolt, Washer and Nut	2	2	2	2	2	2
3	1012-126	1/4" Type "A" Washer	2	2	2	2	2	2
4	8602-040	BKP-24 Bracket with Rod Connector and Set Screw	X	X	X	X	X	X
5	8602-044	1/4" x 7-1/2" Rod	X	X	X	X	X	X
6	137-744BX	Lower Rear Partition	X	X	X			
6	137-740BX	Lower Rear Partition				X	X	X
7	1921-067-2010	Damper Blade Seal	3	3	3			
7	1921-067-2510	Damper Blade Seal				3	3	3
8	1921-067-0802	Damper Blade Seal	2	2	2	2	2	2
9	137-866BX	Upper Front Partition	X	X	X			
9	137-867BX	Upper Front Partition				X	X	X
10	1921-067-2006	Damper Blade Seal	2	2	2			
10	1921-067-2504	Damper Blade Seal				2	2	2
11	1921-067-1004	Damper Blade Seal	2	2	2	2	2	2
12	137-864BX	Upper Rear Partition	X	X	X			
12	137-865BX	Upper Rear Partition				X	X	X
13	101-990BX	Right Side Assembly, Insulated		X	X		X	X
13	101-1036BX	Right Side Assembly, Insulated	X			X		
14	101-978BX	Left Side Assembly, Insulated	X	X	X	X	X	X
15	1921-067-0800	Damper Blade Seal	2	2	2	2	2	2
16	8602-052	1/2" I.D. Bronze Bushing	2	2	2	2	2	2
17	137-742BX	Lower Front Partition	X	X	X			
17	137-738BX	Lower Front Partition				X	X	X
18	137-747BX	Lower Rear Fill	2	2	2			
18	137-745BX	Lower Rear Fill				2	2	2
19	910-2072BX	Outdoor Temperature Sensor Assembly	X			X		
19	910-1979BX	Outdoor Temperature Sensor Assembly			X			X
20	910-1980BX	Outdoor Enthalpy Sensor Assembly		X			X	
21	3000-1526BX	Wire Assembly, Connection to Unit Low Voltage (LH Models)	X	X	X	X	X	X
NS	8602-058BX	Mixed Air Temperature Sensor, 20K		X	X		X	X
NS	113-433BX	Sensor Bracket		X	X		X	X
NS	3000-1646BX	Wire Assembly, Connection to Unit Low Voltage (RH Models)	X			X		
NS	3000-1628BX	Wire Assembly, Connection to Unit Low Voltage (RH Models)		X	X		X	X
NS	3000-1525BX	Wire Assembly, Connection to Unit Low Voltage (RH Models)		X	X		X	X
NS	136-664BX	Condenser Cover Plate	X	X	X			
NS	136-751BX	Condenser Cover Plate				X	X	X
NS	136-1013BX	Return Fill Plate				X	X	X
NS	136-1014BX	Return Fill Plate	X	X	X			

NS – Not Shown

ECONOMIZER AIR HOOD

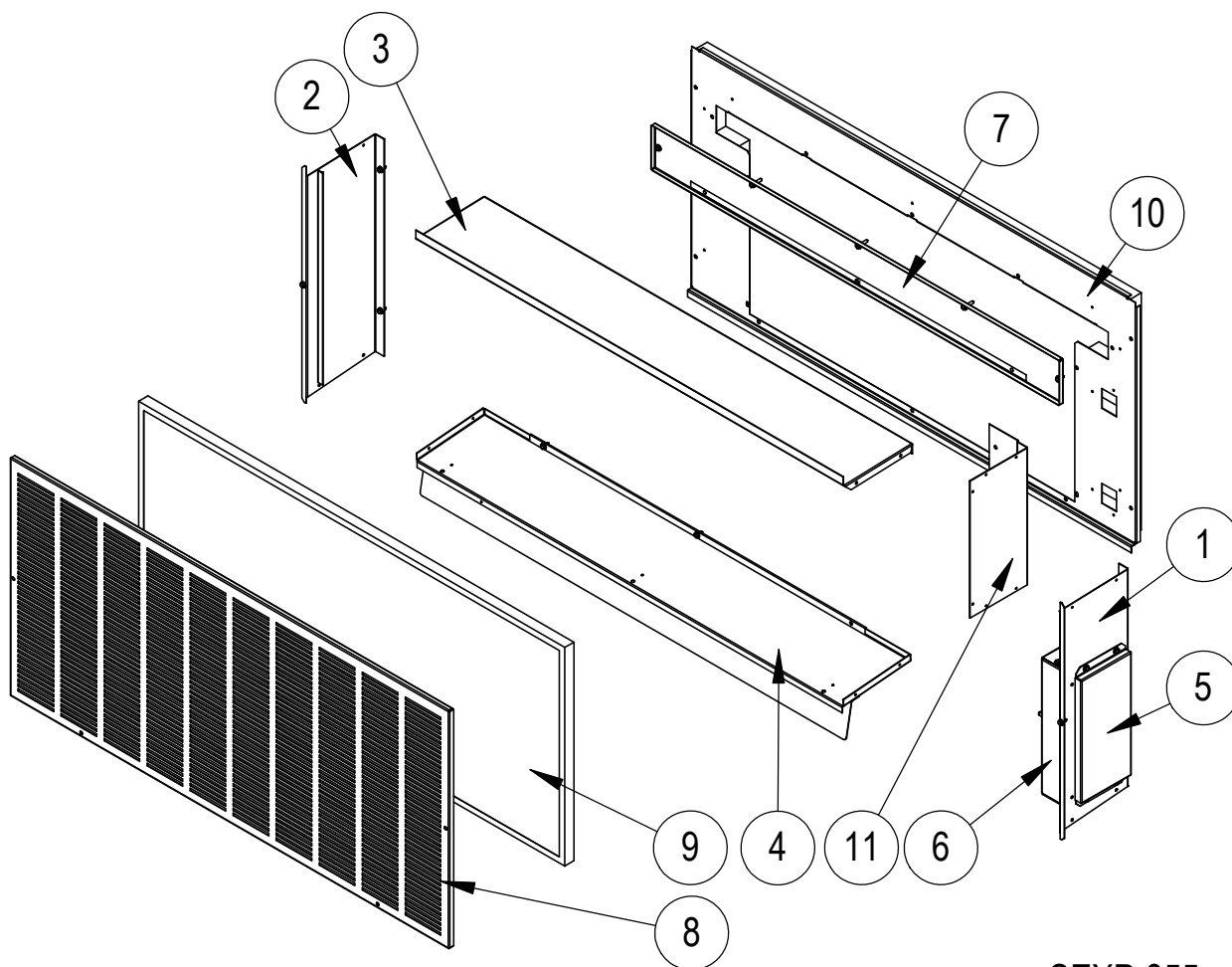

SEXP-955

ECONOMIZER AIR HOOD

Dwg. No.	Part No.	Description	ECON-NC2A	ECON-WD2A	ECON-DB2A	ECON-NC3A	ECON-WD3A	ECON-DB3A
1	101-872-*BX ①	Right Side	X	X	X	X	X	X
1	101-883BX ②	Right Side	X	X	X	X	X	X
1	101-881BX ③	Right Side	X	X	X	X	X	X
2	101-873-*BX ①	Left Side	X	X	X	X	X	X
2	101-884BX ②	Left Side	X	X	X	X	X	X
2	101-882BX ③	Left Side	X	X	X	X	X	X
3	107-424-*BX ①	Hood Top	X	X	X			
3	107-431BX ②	Hood Top	X	X	X			
3	107-426BX ③	Hood Top	X	X	X			
3	107-427-*BX ①	Hood Top				X	X	X
3	107-428BX ②	Hood Top				X	X	X
3	107-429BX ③	Hood Top				X	X	X
4	127-494-*BX ①	Hood Bottom	X	X	X			
4	127-502BX ②	Hood Bottom	X	X	X			
4	127-503BX ③	Hood Bottom	X	X	X			
4	127-495-*BX ①	Hood Bottom				X	X	X
4	127-501BX ②	Hood Bottom				X	X	X
4	127-500BX ③	Hood Bottom				X	X	X
5	133-262-*BX ①	Control Panel Cover	X	X	X	X	X	X
5	133-269BX ②	Control Panel Cover	X	X	X	X	X	X
5	133-270BX ③	Control Panel Cover	X	X	X	X	X	X
6	Control Panel Assembly	See Control Panel Assembly on page 7		X	X		X	X
7	553-775BX	Filter Door	X	X	X			
7	553-776BX ②	Filter Door	X	X	X			
7	553-777BX ③	Filter Door	X	X	X			
7	553-778BX	Filter Door				X	X	X
7	553-779BX ②	Filter Door				X	X	X
7	553-780BX ③	Filter Door				X	X	X
8	115-285-*BX ①	Hood Front	X	X	X			
8	115-292BX ②	Hood Front	X	X	X			
8	115-293BX ③	Hood Front	X	X	X			
8	115-284-*BX ①	Hood Front				X	X	X
8	115-291BX ②	Hood Front				X	X	X
8	115-290BX ③	Hood Front				X	X	X
9	7003-080	Mist Filter (31" X 16" X 1")	X	X	X			
9	7003-079	Mist Filter (36" X 16" X 1")				X	X	X
10	553-769-*BX ①	Hood Mounting Door	X	X	X			
10	553-770BX ②	Hood Mounting Door	X	X	X			
10	553-771BX ③	Hood Mounting Door	X	X	X			
10	553-772-*BX ①	Hood Mounting Door				X	X	X
10	553-773BX ②	Hood Mounting Door				X	X	X
10	553-774BX ③	Hood Mounting Door				X	X	X
11	143-230BX	Blank-Off Plate	X			X		

① Exterior cabinet parts are manufactured with various paint color options. To ensure the proper paint color is received, include the complete model and serial number of the unit for which cabinet parts are being ordered.

② Exterior cabinet parts are manufactured from stainless steel Code "S"

③ Exterior cabinet parts are manufactured from aluminum Code "A"

BLADE ASSEMBLY

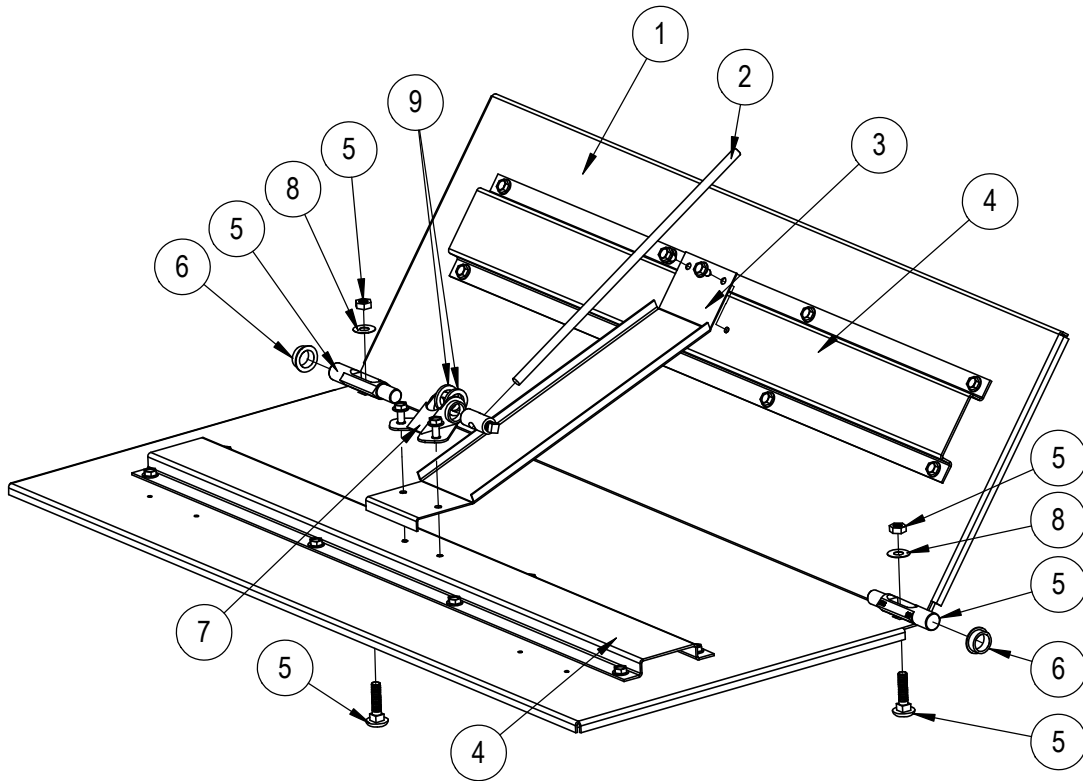

SEXP-918

Dwg. No.	Part No.	Description	ECON-NC2A	ECON-WD2A	ECON-DB2A	ECON-NC3A	ECON-WD3A	ECON-DB3A
1	139-394BX	Blade	X			X		
1	139-393BX	Blade		X	X		X	X
2	8602-042	1/4 x 6" Rod	X	X	X	X	X	X
3	139-403BX	Support Bracket	X	X	X	X	X	X
4	141-433BX	Blade Support	2			2		
4	141-430BX	Blade Support		2	2		2	2
5	8602-038	Damper Pin With Hardware	2	2	2	2	2	2
6	8602-052	1/2" I.D. Bronze Bushing	2	2	2	2	2	2
7	8602-040	BKP-24 Bracket	X	X	X	X	X	X
8	1012-157	Washer	2	2	2	2	2	2
9	1012-348	1/2"x 3/4" Nylon Flat Washer	2	2	2	2	2	2

CONTROL PANEL ASSEMBLY

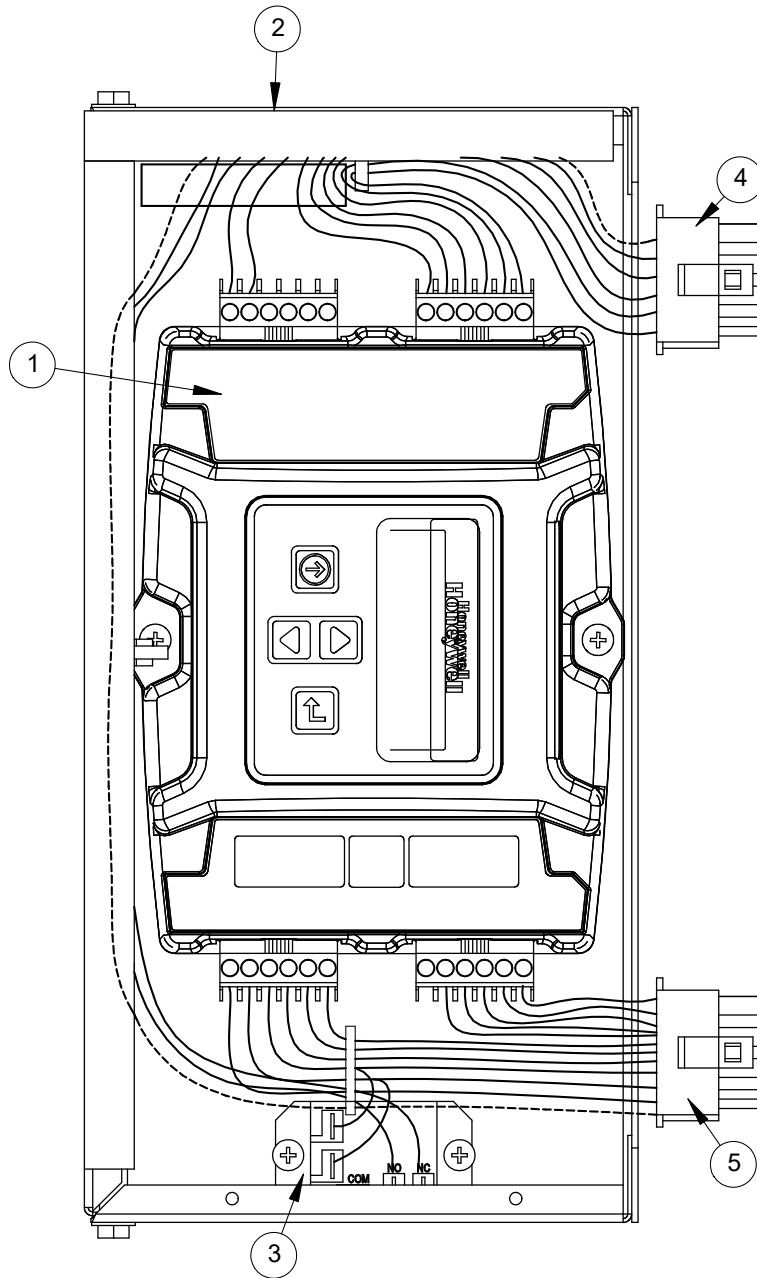

SEXP-749

Dwg. No.	Part No.	Description	ECON-NC2A	ECON-WD2A	ECON-DB2A	ECON-NC3A	ECON-WD3A	ECON-DB3A
1	8602-056-0003BX	Programmed JADE Economizer Module	N/A	X	X	N/A	X	X
2	117-354BX	Control Panel	N/A	X	X	N/A	X	X
3	8201-130BX	Relay, SPDT Pilot Duty	N/A	X	X	N/A	X	X
4	3000-1477BX	Wire Assembly	N/A	X	X	N/A	X	X
5	3000-1657BX	Wire Assembly	N/A	X	X	N/A	X	X

ACTUATOR ASSEMBLY – ECON-NC

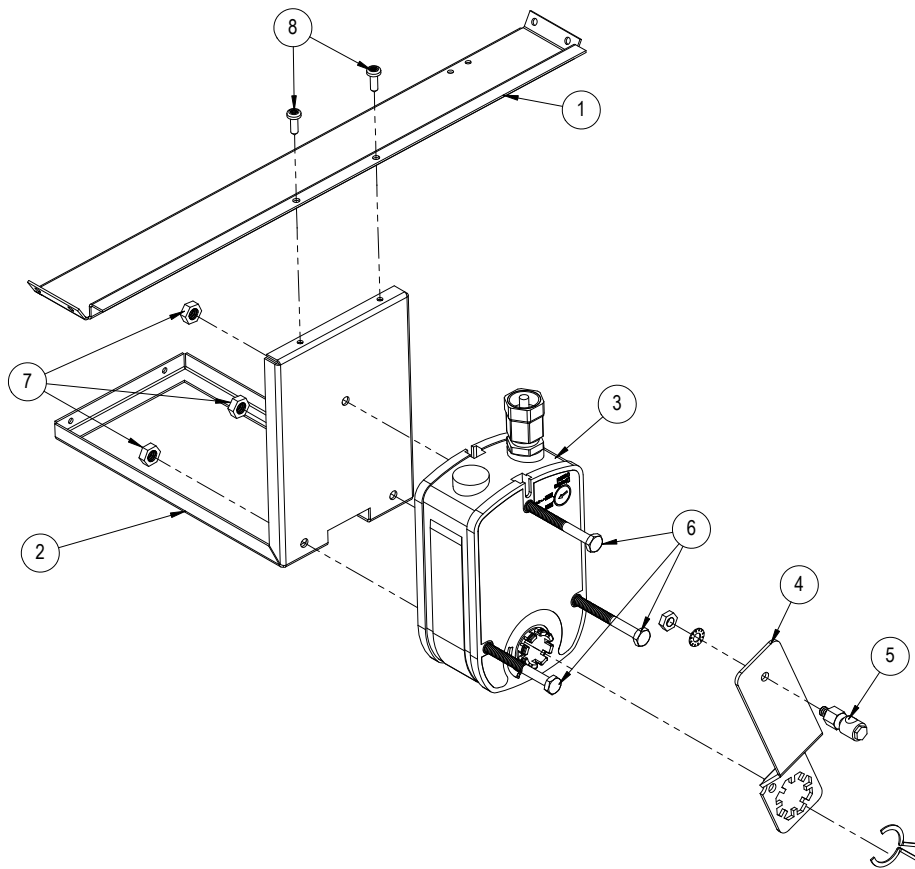

SEXP-1133

Dwg. No.	Part No.	Description	ECON-NC2A	ECON-NC3A
1	141-464BX	Actuator Support	X	X
2	141-610BX	Actuator Support Plate	X	
2	141-609BX	Actuator Support Plate		X
3	8602-075BX	Direct Coupled Actuator	X	X
4	113-1004BX	Actuator Arm	X	X
5	8602-008	Ball Joint	X	X
6	1012-174	1/4"-20X3-1/4 hex cap Screw	3	3
7	1012-201	1/4-20 Steel Keps Hex Nut	3	3
8	1012-128	10-16X5/8" Torx PANHD Platinum	2	2

ACTUATOR ASSEMBLY – ECON-WD/DB

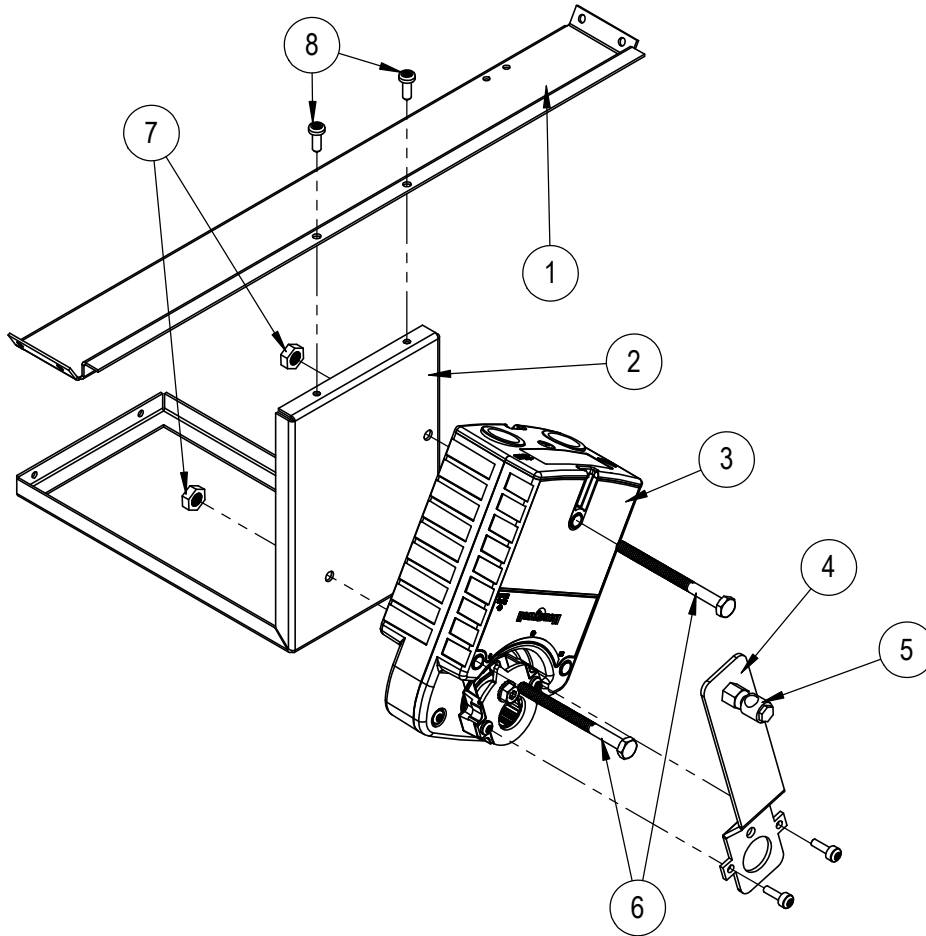

SEXP-917

Dwg. No.	Part No.	Description	ECON-WD2A	ECON-DB2A	ECON-WD3A	ECON-DB3A
1	141-464BX	Actuator Support	X	X	X	X
2	141-491BX	Actuator Support Plate	X	X		
2	141-490BX	Actuator Support Plate			X	X
3	8602-069BX	Direct Coupled Actuator	X	X		
3	8602-059BX	Direct Coupled Actuator-SYLK			X	X
4	113-707BX	Actuator Arm	X	X	X	X
5	8602-008	Ball Joint	X	X	X	X
6	1012-174	1/4"-20X3-1/4 hex cap Screw	2	2	2	2
7	1012-201	1/4-20 Steel Keps Hex Nut	2	2	2	2
8	1012-128	10-16X5/8" Torx PANHD Platinum	2	2	2	2