REPLACEMENT PARTS MANUAL

WALL-MOUNTED PACKAGED AIR CONDITIONER

Models:

HA4S3KA HL4S2KA
HA5S3KA HL5S2KA

General Notes

- Revised and/or additional pages may be issued from time to time.
- A complete and current manual consists of pages shown in the following contents section.

Important

- Contact the installing and/or local Bard distributor for all parts requirements. Make sure to have the complete model and serial number available from the unit rating plates.

Contents

<u>Description</u>	<u>Page</u>
Cabinet Components – Right Hand	
♦ Exploded View	2
♦ Usage List (HA4S3KA & HA5S3KA).....	3
Cabinet Components – Left Hand	
♦ Exploded View	4
♦ Usage List (HL4S2KA & HL5S2KA)	5
Functional Components – RH (shown)/LH (mirrored)	
♦ Exploded View	6
♦ Usage List (Right Hand).....	7
♦ Usage List (Left Hand).....	8
Control Panel – RH (shown)/LH (mirrored)	
♦ Exploded View	9
♦ Usage List (Right Hand).....	10
♦ Usage List (Left Hand).....	11
Blower Assembly – Right & Left Hand	
♦ Exploded View	12
♦ Usage List	12



Bard Manufacturing Company, Inc.
Bryan, Ohio 43506
www.bardhvac.com

Manual: 2110-1405F
Supersedes: 2110-1405E
Date: 1-29-15

CABINET COMPONENTS - RIGHT HAND

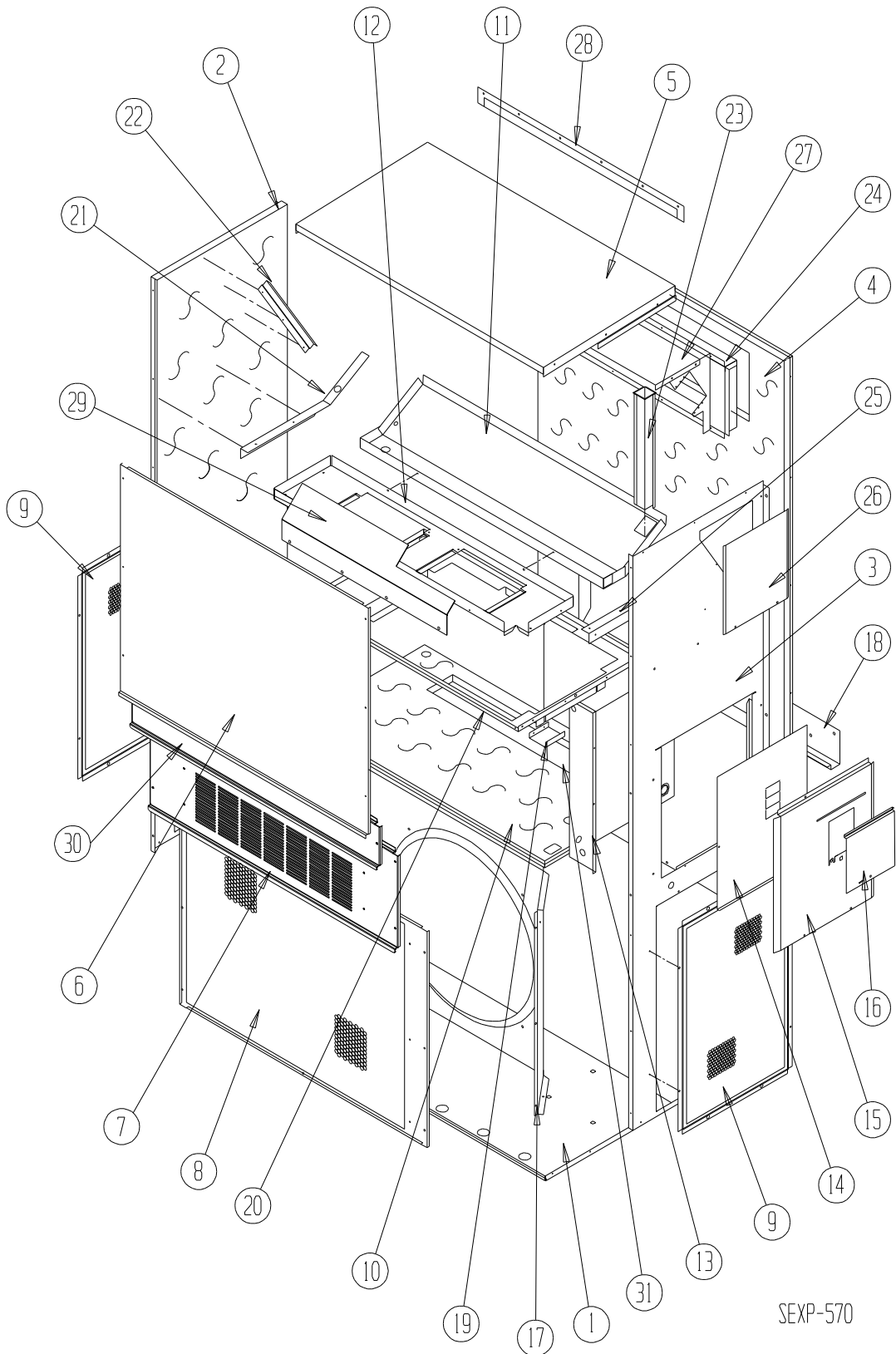

SEXP-570

CABINET COMPONENTS - RIGHT HAND

Dwg. No.	Part Number	Description	HA4S3KA	HA5S3KA
1	S127-342-4	Lower Base	X	X
1	S127X405 ③	Lower Base	X	X
2	S500-316-* ①	Left Side	X	X
2	S500-545 ②	Left Side	X	X
2	S500-543 ③	Left Side	X	X
3	S500-315-* ①	Right Side	X	X
3	S500-546 ②	Right Side	X	X
3	S500-544 ③	Right Side	X	X
4	S508-129	Back	X	X
4	S508-229 ②	Back	X	X
4	S508-228 ③	Back	X	X
5	S506-142-* ①	Top	X	X
5	S506-251 ②	Top	X	X
5	S506-274 ③	Top	X	X
6	S515-144-* ①	Upper Front	X	X
6	S515-142 ②	Upper Front	X	X
6	S515-162 ③	Upper Front	X	X
7	S553-383-* ①	Vent Option Door	X	X
7	S553-408-* ①	Vent Option Door with ERV	X	X
7	S552-456 ②	Vent Option Door	X	X
7	S553-449 ③	Vent Option Door	X	X
8	118-052-* ①	Condenser Grille	X	X
8	118-080 ②	Condenser Grille	X	X
8	118-078 ③	Condenser Grille	X	X
9	118-058-* ①	Side Grille	2	2
9	118-081 ②	Side Grille	2	2
9	118-079 ③	Side Grille	2	2
10	S521X258	Condenser Partition	X	X
11	S523-125	Drain Pan	X	X
12	121X216	Blower Partition	X	X
13	Control Panel Assembly	See Control Panel Assembly Drawing and Parts List Assembly	X	X
14	S132-114	Control Panel Cover (Inner)	X	X
15	S533-113-* ①	Control Panel Cover (Outer)	X	X
15	S533-185 ②	Control Panel Cover (Outer)	X	X
15	S533-195 ③	Control Panel Cover (Outer)	X	X
16	S153-218-* ①	Disconnect Access Door	X	X
16	S153-387 ②	Disconnect Access Door	X	X
16	S153-405 ③	Disconnect Access Door	X	X
17	125-050	Fan Shroud	X	X
17	125-062 ③	Fan Shroud	X	X
18	113-140	Bottom Mounting Bracket	X	X
19	137-209	Fill	X	X
20	S131X164	Filter Tray	X	X
21	105X877	Left Side Support	X	X
22	147-046	Left Evaporator Support	X	X
24	S111X034	Outlet Air Frame Assembly	X	X
25	105X878	Right Side Support	X	X
26	S143-042-* ①	Right Side Cover Plate (Outer)	X	X
26	S143-105 ②	Right Side Cover Plate (Outer)	X	X
26	S143-125 ③	Right Side Cover Plate (Outer)	X	X
27	135-129	Heat Shield	X	X
28	113-150-* ①	Top Rain Flashing	X	X
28	113-359-* ③	Top Rain Flashing	X	X
30	S553-384-* ①	Filter Door Assembly	X	X
30	S552-457 ②	Filter Door Assembly	X	X
30	S553-450 ③	Filter Door Assembly	X	X
34	S536-258	Condenser Part. Blank-Off Plate	X	X
NS	105-1324	Close-Off Angle	X	X

① Exterior cabinet parts are manufactured with various paint color options. To ensure the proper paint color is received, include the complete model and serial number of the unit for which cabinet parts are being ordered.

② Exterior cabinet parts are manufactured from aluminum Code "A"

NS = Not Shown

③ Exterior cabinet parts are manufactured from stainless steel Code "S"

CABINET COMPONENTS - LEFT HAND

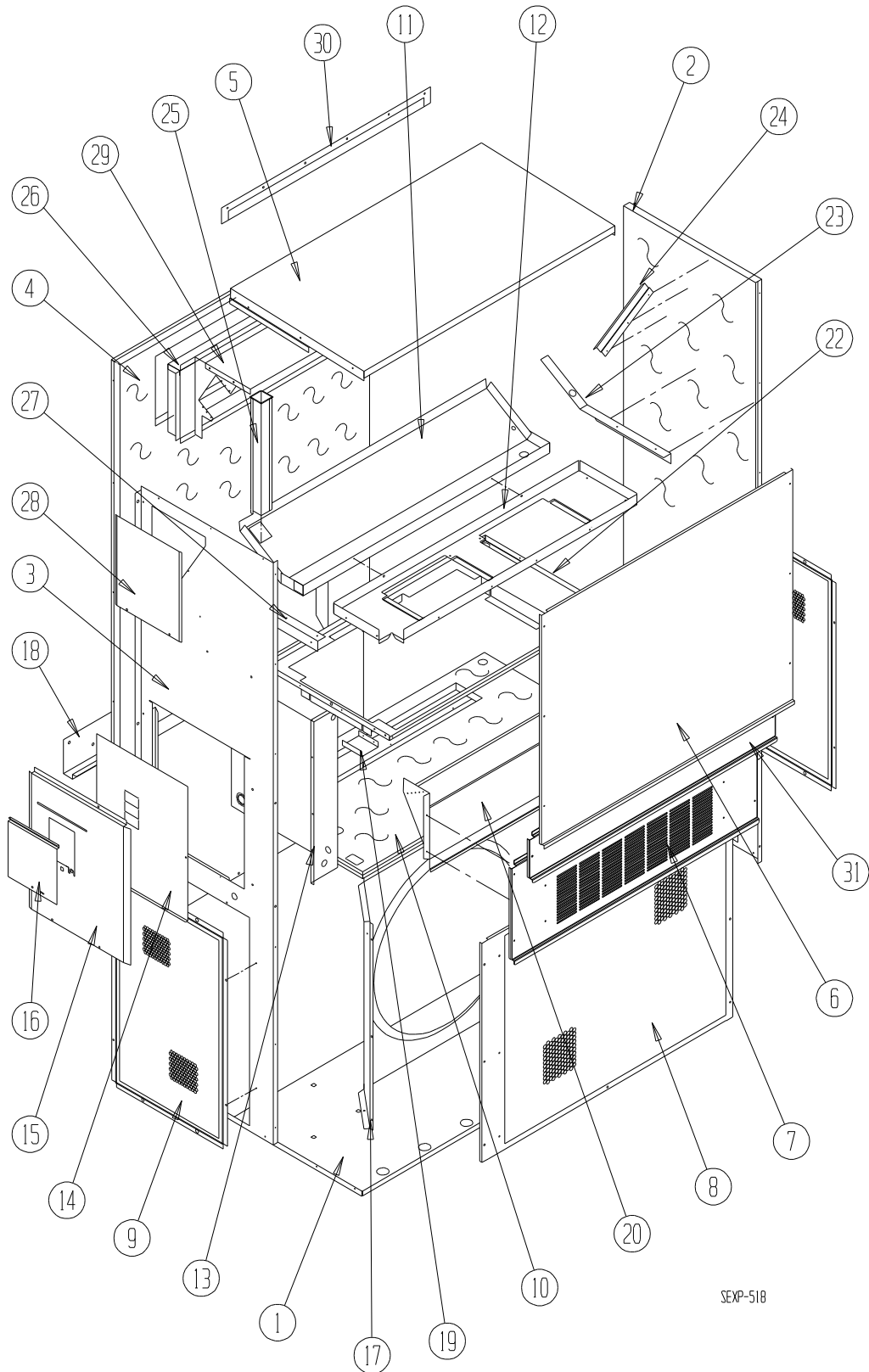

SEXP-518

CABINET COMPONENTS - LEFT HAND

Dwg. No.	Part Number	Description	HL4S2KA	HL5S2KA
1	S127-403-4	Lower Base	X	X
1	S127Y369 ③	Lower Base	X	X
2	S500-367-* ①	Right Side	X	X
2	S500-547 ②	Right Side	X	X
2	S500-681 ③	Right Side	X	X
3	S500-368-* ①	Left Side	X	X
3	S500-548 ②	Left Side	X	X
3	S500-682 ③	Left Side	X	X
4	S508-129 ①	Back	X	X
4	S508-229 ②	Back	X	X
4	S508-228 ③	Back	X	X
5	S506-142-* ①	Top	X	X
5	S506-251 ②	Top	X	X
5	S506-274 ③	Top	X	X
6	S515-144-* ①	Upper Front	X	X
6	S514-142 ②	Upper Front	X	X
6	S514-162 ③	Upper Front	X	X
7	S553-383-* ①	Vent Option Door	X	X
7	S552-456 ②	Vent Option Door	X	X
7	S553-449 ③	Vent Option Door	X	X
8	118-053-* ①	Condenser Grille	X	X
8	118-082 ②	Condenser Grille	X	X
8	118-091 ③	Condenser Grille	X	X
9	118-058-* ①	Side Grille	2	2
9	118-081 ②	Side Grille	2	2
9	118-079 ③	Side Grille	2	2
10	S521Y258	Condenser Partition	X	X
11	S523-137	Drain Pan	X	X
12	121Y216	Blower Partition	X	X
13	Control Panel Assembly	See Control Panel Assembly Drawing and Parts List Assembly	X	X
14	S132-114	Control Panel Cover (Inner)	X	X
15	S533-140-* ①	Control Panel Cover (Outer)	X	X
15	S533-186 ②	Control Panel Cover (Outer)	X	X
15	S533-203 ③	Control Panel Cover (Outer)	X	X
16	S153-218-* ①	Disconnect Access Door	X	X
16	S153-387 ②	Disconnect Access Door	X	X
16	S153-405 ③	Disconnect Access Door	X	X
17	125X050	Fan Shroud	X	X
17	125-062 ③	Fan Shroud	X	X
18	113-140	Bottom Mounting Bracket	X	X
19	137-209	Fill	X	X
20	BFAD-5	Fresh Air Damper Assembly	X	X
22	S131Y164	Filter Tray	X	X
23	105Y878	Left Side Support	X	X
24	147-046	Left Evaporator Support	X	X
25	135-128	Raceway	2	2
26	S111Y034	Outlet Air Frame Assembly	X	X
27	105Y877	Right Side Support	X	X
28	S143-042-* ①	Right Side Cover Plate (Outer)	X	X
28	S143-105 ②	Right Side Cover Plate (Outer)	X	X
28	S143-125 ③	Right Side Cover Plate (Outer)	X	X
29	135-129	Heat Shield	X	X
30	113-150-* ①	Top Rain Flashing	X	X
30	113-359-* ③	Top Rain Flashing	X	X
31	S553-384-* ①	Filter Door Assembly	X	X
31	S552-457 ②	Filter Door Assembly	X	X
31	S553-450 ③	Filter Door Assembly	X	X
NS	S536-498	Condenser Part. Blank-Off Plate	X	X
NS	105-1324	Close-Off Angle	X	X

① Exterior cabinet parts are manufactured with various paint color options. To ensure the proper paint color is received, include the complete model and serial number of the unit for which cabinet parts are being ordered.

② Exterior cabinet parts are manufactured from aluminum Code "A"

NS = Not Shown

③ Exterior cabinet parts are manufactured from stainless steel Code "S"

FUNCTIONAL COMPONENTS - RH (shown)/LH (mirrored)

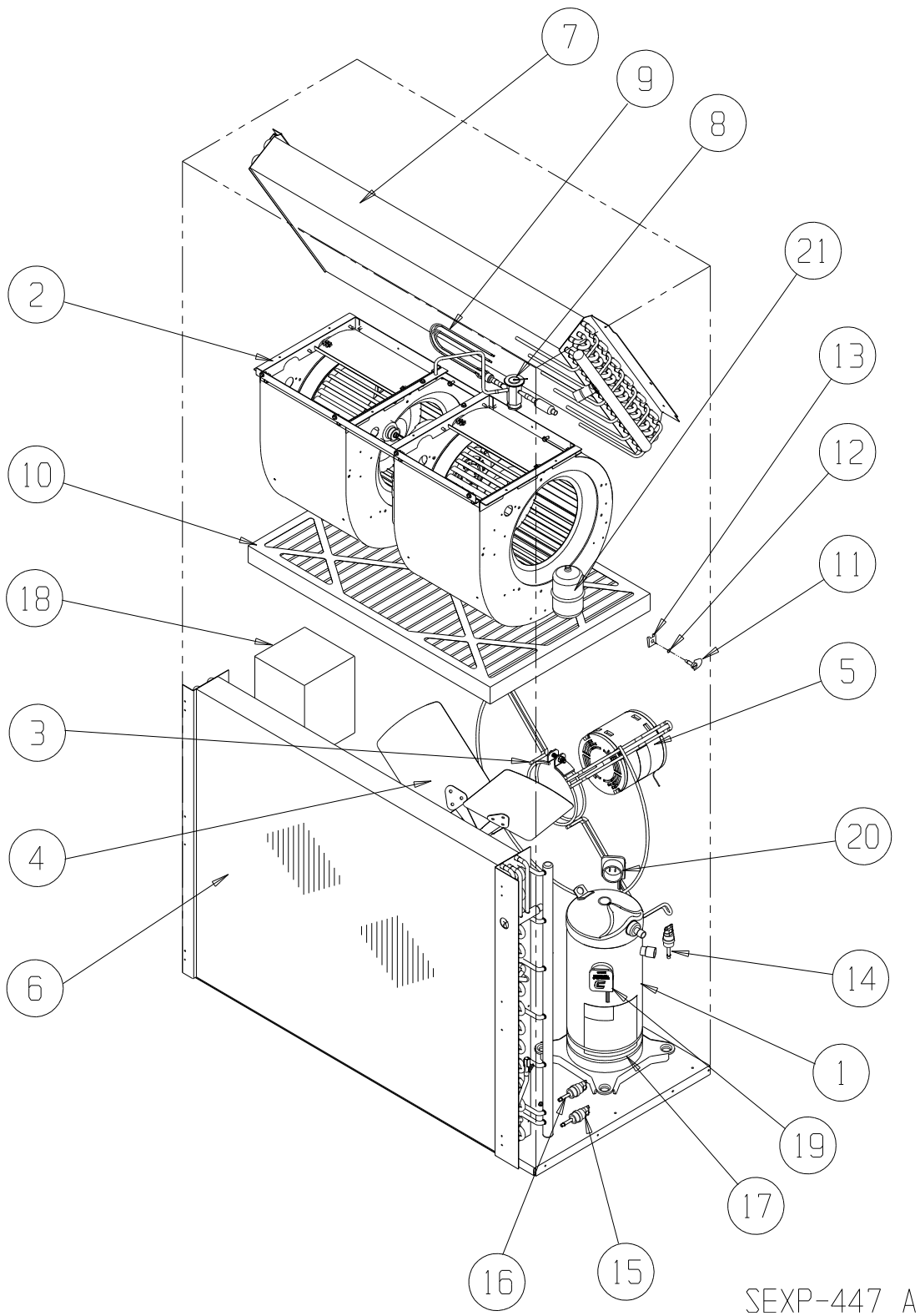

FUNCTIONAL COMPONENTS (RIGHT HAND)

Dwg. No.	Part Number	Description	HA4S3KA	HA5S3KA
1	8000-382	Compressor	X	
1	8000-385	Compressor		X
2	S900-273-002	Blower Assembly	X	
2	S900-273-003	Blower Assembly		X
3	8200-004	Fan Motor Mount	X	X
4	5151-027	Fan Blade	X	X
5	8105-039	Condenser Motor	X	X
6	5051-129BX	Condenser Coil	X	X
7	5060-122BX	Evaporator	X	X
8	905-0635	TXV Assembly	X	
8	905-0636	TXV Assembly		X
9	800-0342	Cooling Distributor	X	X
10	7004-016	20" x 30" x 1" Disposable	X	X
10	7003-030	20" x 30" x 1" Washable	X	X
10	7004-027	20" x 30" x 2" Pleated Filter	X	X
11	1171-022	1/4 Turn Fastener	X	X
12	1171-024	1/4 Turn Retainer	X	X
13	1171-023	1/4 Turn Receptacle	X	X
14	1804-0386	Low Pressure Switch (Flare)	X	X
15	8406-112	Low Ambient Control (Flare)	X	X
16	1804-0462	High Pressure Switch (Flare)	X	X
17	8605-017	Crankcase Heater	X	X
19	3000-1222	Compressor Power Lead	X	X
20	3000-1223	Compressor Staging Solenoid Lead	X	X
21	5201-002	Liquid Line Filter Drier	X	X
NS	5202-022	Accumulator	X	X

FUNCTIONAL COMPONENTS (LEFT HAND)

Dwg. No.	Part Number	Description	HL4S2KA	HL5S2KA
1	8000-382	Compressor	X	
1	8000-385	Compressor		X
2	S900-273-002	Blower Assembly	X	
2	S900-273-003	Blower Assembly		X
3	8200-004	Fan Motor Mount	X	X
4	5151-027	Fan Blade	X	X
5	8105-039	Condenser Motor	X	X
6	5051-166BX	Condenser Coil	X	X
7	5060-122BX	Evaporator	X	X
8	905-0632	TXV Assembly	X	
8	905-0633	TXV Assembly		X
9	800-0342	Cooling Distributor	X	X
10	7004-016	20" x 30" x 1" Disposable	X	X
10	7003-030	20" x 30" x 1" Washable	X	X
10	7004-027	20" x 30" x 2" Pleated Filter	X	X
11	1171-022	1/4 Turn Fastener	X	X
12	1171-024	1/4 Turn Retainer	X	X
13	1171-023	1/4 Turn Receptacle	X	X
14	1804-0386	Low Pressure Switch (Flare)	X	X
15	8406-112	Low Ambient Control (Flare) ①	X	X
16	1804-0462	High Pressure Switch (Flare)	X	X
17	8605-017	Crankcase Heater	X	X
19	3000-1222	Compressor Power Lead	X	X
20	3000-1223	Compressor Staging Solenoid Lead	X	X
21	5201-002	Liquid Line Filter Drier	X	X
22	5202-022	Accumulator	X	X

① = Optional

CONTROL PANEL – RH (shown)/LH (mirrored)

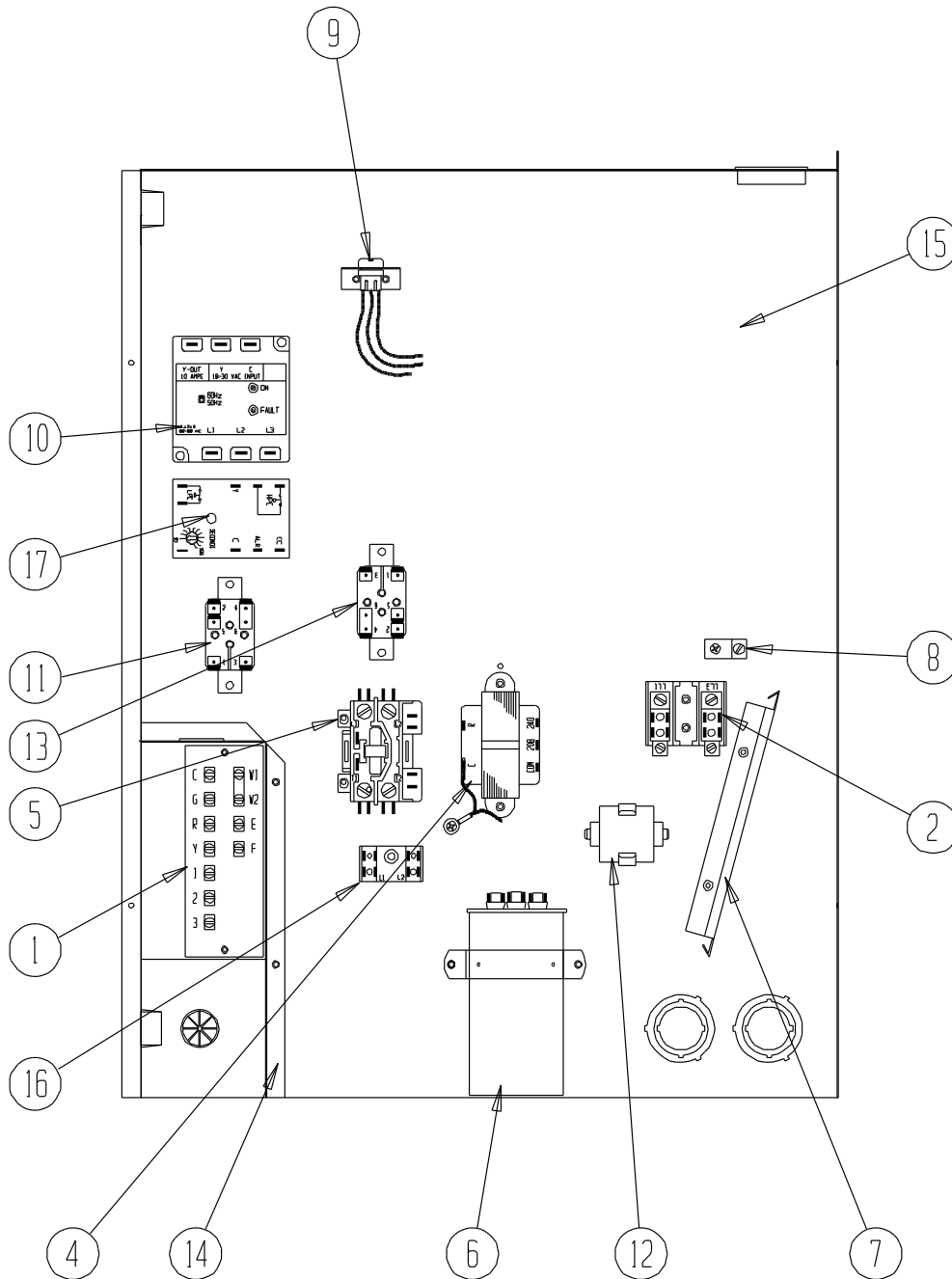

SEXP-449

CONTROL PANEL (RIGHT HAND)

Dwg. No.	Part Number	Description	HA4S3KA	HA5S3KA
1	8607-024	Low Voltage Terminal Strip	X	X
2	8607-013	Terminal Block 2-Pole	X	X
4	8407-048	Transformer (75VA)	X	X
5	8401-025	Compressor Contactor	X	X
6	8552-094	Compressor/Fan Capacitor	X	
6	8552-055	Compressor/Fan Capacitor		X
7	135-130	Wire Shield	X	X
8	8611-006	Ground Terminal	X	X
9	3000-1318	6-Pin Connector	X	X
11	8201-062	Alarm Relay ①	2	2
12	8551-004	Motor Starting Device (1-PH Only)	X	X
13	8201-009	Crankcase Heat Relay	X	X
14	117X139	Low Voltage Box	X	X
15	117X143	Control Panel Box	X	X
16	8607-017	Terminal Block ①	X	X
17	8201-148	Compressor Control Module	X	X
NS	4095-160	Wiring Diagram	X	X
NS	8301-011	Dirty Filter Switch	X	X

NS = Not Shown

① = Optional

CONTROL PANEL (LEFT HAND)

Dwg. No.	Part Number	Description	HL4S2KA	HL5S2KA
1	8607-024	Low Voltage Terminal Strip	X	X
2	8607-013	Terminal Block 2-Pole	X	X
4	8407-048	Transformer (75VA)	X	X
5	8401-025	Compressor Contactor	X	X
6	8552-094	Compressor/Fan Capacitor	X	
6	8552-055	Compressor/Fan Capacitor		X
7	135-130	Wire Shield	X	X
8	8611-006	Ground Terminal	X	X
9	3000-1318	6-Pin Connector	X	X
11	8201-062	Alarm Relay ①	2	2
12	8551-004	Motor Starting Device (1-PH Only)	X	X
13	8201-009	Crankcase Heat Relay	X	X
14	117Y139	Low Voltage Box	X	X
15	117Y143	Control Panel Box	X	X
16	8607-017	Terminal Block ①	X	X
17	8201-148	Compressor Control Module	X	X
NS	4095-160	Wiring Diagram	X	X
NS	8301-011	Dirty Filter Switch	X	X

NS = Not Shown

① = Optional

BLOWER ASSEMBLY

Dwg. No.	Part Number	Description	HA/L4S*KA	HA/L5S*KA
1	5152-011	10-Inch Wheel (CW)	X	X
2	5152-012	10-Inch Wheel (CCW)	X	X
3	S8107-017-0039B	3/4 HP Programmed Motor	X	
3	S8107-017-0036A	3/4 HP Programmed Motor		X
4	C8107-017-0039B	Programmed Motor Control Only	X	
4	C8107-017-0036A	Programmed Motor Control Only		X
5	112-344	Blower Motor Control Bracket	X	X
6	8200-040	Motor Mount	X	X
7	5451-011	Grommets	6	6
8	105-881	Back Brace	X	X
9	105-880	Side Angle	4	4
10	103-389	Front Brace	X	X
11	151-101	Housing	2	2
12	144-166	Diffuser	2	2

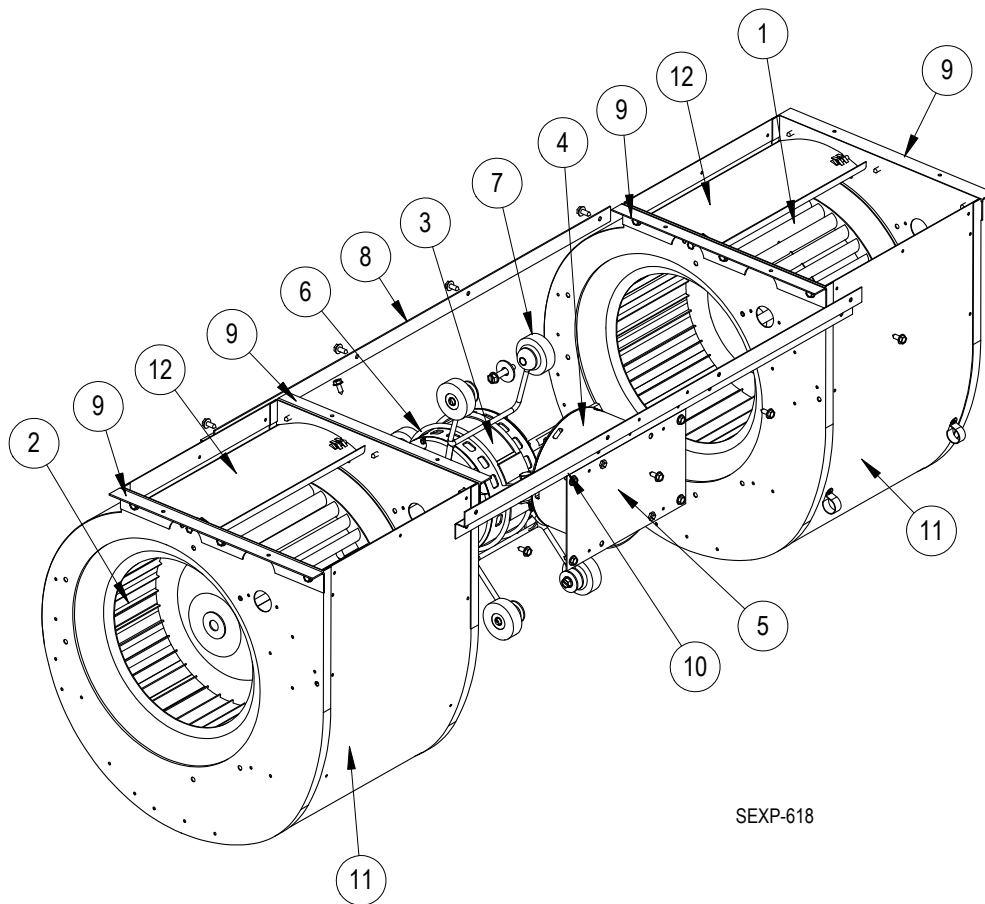

SEXP-618