REPLACEMENT PARTS MANUAL

WALL MOUNTED PACKAGE AIR CONDITIONER

Models: **W42L2**
W48L2
W60L2
W70L2

General Notes

- Revised and/or additional pages may be issued from time to time.
- A complete and current manual consists of pages shown in the following contents section.

Important

- Contact the installing and/or local Bard distributor for all parts requirements. Make sure you have the complete model and serial number available from the unit rating plates.

Contents

<u>Description</u>	<u>Page</u>
Cabinet Components	
♦ Exploded View	2
♦ Usage List	3
♦ Usage List	4
Functional Components	
♦ Exploded View	5
♦ Usage List	6
♦ Usage List	7
Control Panel	
♦ Exploded View	8
♦ Usage List	9
♦ Usage List	10
Blower Assembly	
♦ Exploded View	11
♦ Usage List	11



Bard Manufacturing Company, Inc.
Bryan, Ohio 43506
Since 1914...Moving ahead, just as planned.

Manual: 2110-1406C
Supersedes: 2110-1406B
File: Tab 16
Date: 02-06-14

CABINET COMPONENTS

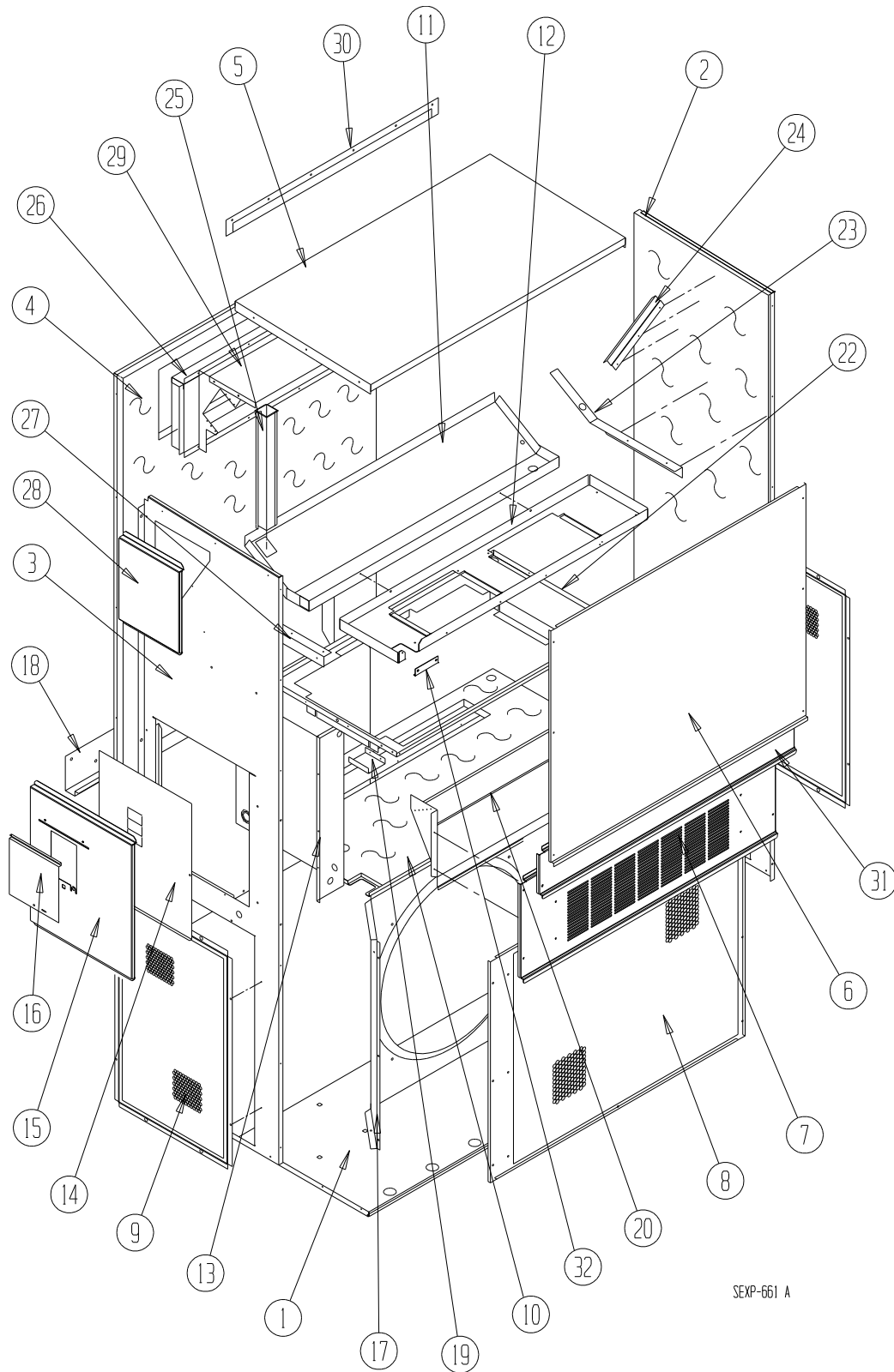

SEXP-661 A

CABINET COMPONENTS

Dwg No.	Part Number	Description	W42L2-A, B	W42L2-C, F	W48L2-A, B	W48L2-C, F	W60L2-A, B	W60L2-C, F
1	S127-428	Lower Base	X	X	X	X	X	X
1	S127-436 ③	Lower Base	X	X	X	X	X	X
2	S501-687-* ①	Right Side	X	X	X	X	X	X
2	S501-713 ②	Right Side	X	X	X	X	X	X
2	S501-715 ③	Right Side	X	X	X	X	X	X
3	S501-680-* ①	Left Side	X	X	X	X	X	X
3	S501-714 ②	Left Side	X	X	X	X	X	X
3	S501-716 ③	Left Side	X	X	X	X	X	X
4	S508-098	Back	X	X	X	X	X	X
4	S508-275 ②	Back	X	X	X	X	X	X
4	S508-221 ③	Back	X	X	X	X	X	X
5	S507-307-* ①	Top	X	X	X	X	X	X
5	S507-309 ②	Top	X	X	X	X	X	X
5	S507-310 ③	Top	X	X	X	X	X	X
6	S515-230-* ①	Upper Front	X	X	X	X	X	X
6	S514-231 ②	Upper Front	X	X	X	X	X	X
6	S514-232 ③	Upper Front	X	X	X	X	X	X
7	S553-522-* ①	Vent Option Door	X	X	X	X	X	X
7	S553-525 ②	Vent Option Door	X	X	X	X	X	X
7	S553-527 ③	Vent Option Door	X	X	X	X	X	X
8	118-049-* ①	Condenser Grille	X	X	X	X	X	X
8	118-065 ②	Condenser Grille	X	X	X	X	X	X
8	118-074 ③	Condenser Grille	X	X	X	X	X	X
9	118-057-* ①	Side Grille	2	2	2	2	2	2
9	118-063 ②	Side Grille	2	2	2	2	2	2
9	118-073 ③	Side Grille	2	2	2	2	2	2
10	S521Y462	Condenser Partition	X	X	X	X	X	X
11	S123-121	Drain Pan	X	X	X	X	X	X
11	S123-137 ②③	Drain Pan	X	X	X	X	X	X
12	121Y463	Blower Partition	X	X	X	X	X	X
13	Control Panel Assy.	See Control Panel Assy. Drawing & Parts List	X	X	X	X	X	X
14	S133-114	Control Panel Cover (Inner)	X		X		X	
14	S133-171	Control Panel Cover (Inner)		X		X		X
15	S533-227-* ①	Control Panel Cover (Outer)	X	X	X	X	X	X
15	S533-231 ②	Control Panel Cover (Outer)	X	X	X	X	X	X
15	S533-233 ③	Control Panel Cover (Outer)	X	X	X	X	X	X
16	S153-218-* ①	Disconnect Access Door	X	X	X	X	X	X
16	S153-387 ②	Disconnect Access Door	X	X	X	X	X	X
16	S153-405 ③	Disconnect Access Door	X	X	X	X	X	X
17	125-024	Fan Shroud	X	X	X	X	X	X
17	125-058 ③	Fan Shroud	X	X	X	X	X	X
18	113-140	Bottom Mounting Bracket	X	X	X	X	X	X
19	137-209	Fill	X	X	X	X	X	X
20	BFAD-5	Fresh Air Damper Assembly	X	X	X	X	X	X
22	131Y099	Filter Tray	X	X	X	X	X	X
23	105Y878	Left Side Support	X	X	X	X	X	X
24	147-046	Left Evaporator Support	X	X	X	X	X	X
25	135-128	Raceway	2	2	2	2	2	2
26	S111Y034	Outlet Air Frame Assembly	X	X	X	X	X	X
27	105Y877	Right Side Support	X	X	X	X	X	X
28	S543-172-* ①	Right Side Cover Plate (Outer)	X	X	X	X	X	X
28	S543-176 ②	Right Side Cover Plate (Outer)	X	X	X	X	X	X
28	S543-177 ③	Right Side Cover Plate (Outer)	X	X	X	X	X	X
29	135-129	Heat Shield	X	X	X	X	X	X
30	113-150-* ①	Top Rain Flashing	X	X	X	X	X	X
30	113-359 ③	Top Rain Flashing	X	X	X	X	X	X
31	S553-521-* ①	Filter Door Assembly	X	X	X	X	X	X
31	S553-526 ②	Filter Door Assembly	X	X	X	X	X	X
31	S553-528 ③	Filter Door Assembly	X	X	X	X	X	X
32	105-1302	Grommet Retainer	X	X	X	X	X	X
NS	S536-498	Cond. Partition Block Off Plate	X	X	X	X	X	X

① Exterior cabinet parts are manufactured with various paint color options. To insure that you receive the proper paint color, you must include the complete model and serial number of the unit for which cabinet parts are being ordered.

② Note: Exterior cabinet parts are manufactured from aluminum Code "A"

③ Note: Exterior cabinet parts are manufactured from stainless steel Code "S"

NS = Not Shown

CABINET COMPONENTS

Dwg No.	Part Number	Description	W70L2-A, B	W70L2-C, F
1	S127-428	Lower Base	X	X
1	S127-436 ③	Lower Base	X	X
2	S501-687-* ①	Right Side	X	X
2	S501-713 ②	Right Side	X	X
2	S501-715 ③	Right Side	X	X
3	S501-680-* ①	Left Side	X	X
3	S501-714 ②	Left Side	X	X
3	S501-716 ③	Left Side	X	X
4	S508-098	Back	X	X
4	S508-275 ②	Back	X	X
4	S508-221 ③	Back	X	X
5	S507-307-* ①	Top	X	X
5	S507-309 ②	Top	X	X
5	S507-310 ③	Top	X	X
6	S515-230-* ①	Upper Front	X	X
6	S514-231 ②	Upper Front	X	X
6	S514-232 ③	Upper Front	X	X
7	S553-522-* ①	Vent Option Door	X	X
7	S553-525 ②	Vent Option Door	X	X
7	S553-527 ③	Vent Option Door	X	X
8	118-049-* ①	Condenser Grille	X	X
8	118-065 ②	Condenser Grille	X	X
8	118-074 ③	Condenser Grille	X	X
9	118-057-* ①	Side Grille	2	2
9	118-063 ②	Side Grille	2	2
9	118-073 ③	Side Grille	2	2
10	S521Y462	Condenser Partition	X	X
11	S123-121	Drain Pan	X	X
11	S123-137 ②③	Drain Pan	X	X
12	121Y463	Blower Partition	X	X
13	Control Panel Assy.	See Control Panel Assy. Drawing & Parts List	X	X
14	S133-114	Control Panel Cover (Inner)	X	
14	S133-171	Control Panel Cover (Inner)		X
15	S533-227-* ①	Control Panel Cover (Outer)	X	X
15	S533-231 ②	Control Panel Cover (Outer)	X	X
15	S533-233 ③	Control Panel Cover (Outer)	X	X
16	S153-218-* ①	Disconnect Access Door	X	X
16	S153-387 ②	Disconnect Access Door	X	X
16	S153-405 ③	Disconnect Access Door	X	X
17	125-024	Fan Shroud	X	X
17	125-058 ③	Fan Shroud	X	X
18	113-140	Bottom Mounting Bracket	X	X
19	137-209	Fill	X	X
20	BFAD-5	Fresh Air Damper Assembly	X	X
22	131Y099	Filter Tray	X	X
23	105Y878	Left Side Support	X	X
24	147-046	Left Evaporator Support	X	X
25	135-128	Raceway	2	2
26	S111Y034	Outlet Air Frame Assembly	X	X
27	105Y877	Right Side Support	X	X
28	S543-172-* ①	Right Side Cover Plate (Outer)	X	X
28	S543-176 ②	Right Side Cover Plate (Outer)	X	X
28	S543-177 ③	Right Side Cover Plate (Outer)	X	X
29	135-129	Heat Shield	X	X
30	113-150-* ①	Top Rain Flashing	X	X
30	113-359 ③	Top Rain Flashing	X	X
31	S553-521-* ①	Filter Door Assembly	X	X
31	S553-526 ②	Filter Door Assembly	X	X
31	S553-528 ③	Filter Door Assembly	X	X
32	105-1302	Grommet Retainer	X	X
NS	S536-498	Cond. Partition Block Off Plate	X	X

① Exterior cabinet parts are manufactured with various paint color options. To insure that you receive the proper paint color, you must include the complete model and serial number of the unit for which cabinet parts are being ordered.

② Note: Exterior cabinet parts are manufactured from aluminum Code "A"

③ Note: Exterior cabinet parts are manufactured from stainless steel Code "S"

FUNCTIONAL COMPONENTS

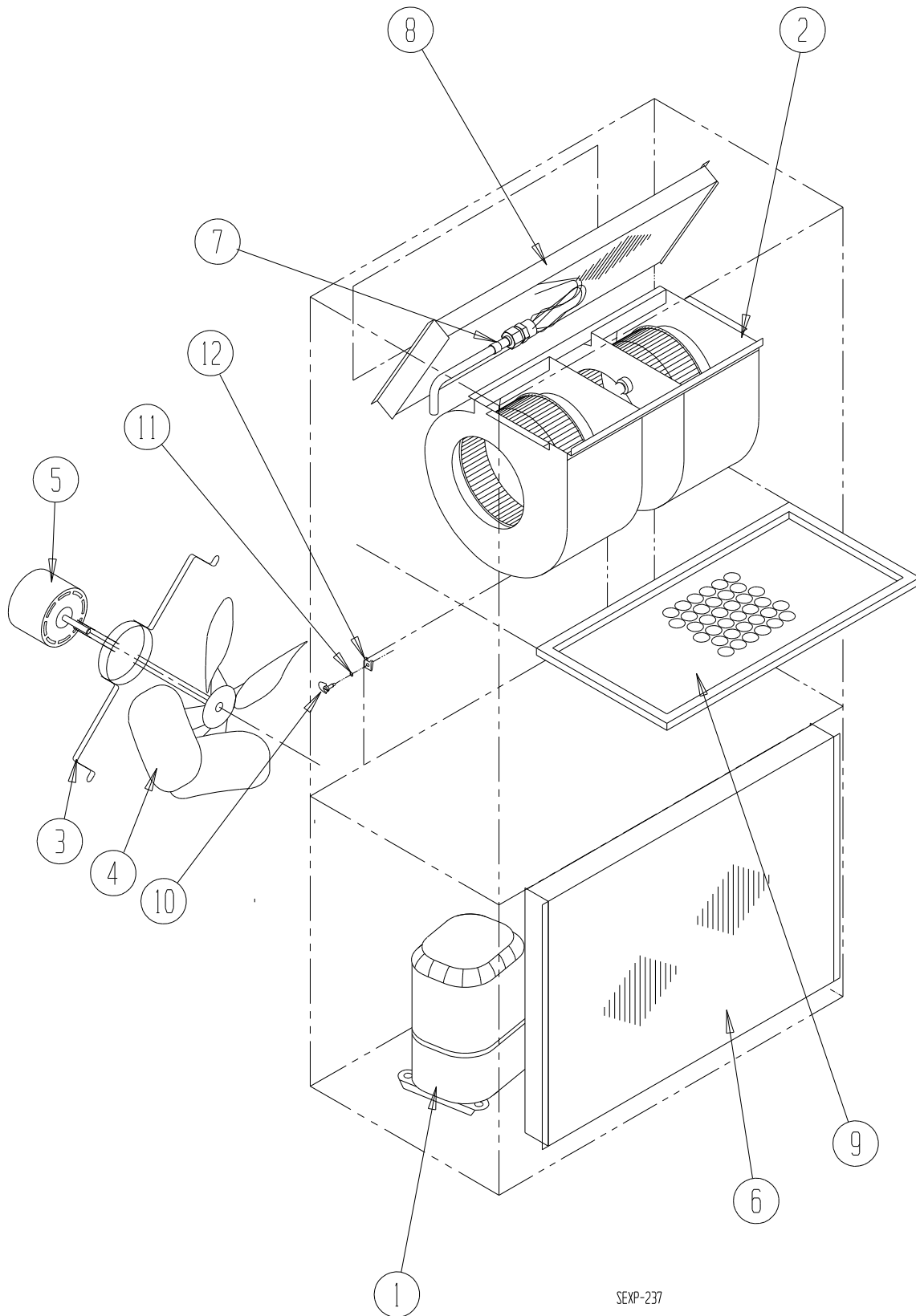

FUNCTIONAL COMPONENTS

Dwg No.	Part Number	Description	W42L2-A	W42L2-B	W42L2-C	W42L2-F	W48L2-A	W48L2-B	W48L2-C	W48L2-F	W60L2-A	W60L2-B	W60L2-C	W60L2-F
1	8000-318	Compressor	X											
1	8000-319	Compressor		X										
1	8000-320	Compressor			X	X								
1	8000-400	Compressor					X							
1	8000-401	Compressor						X						
1	8000-402	Compressor							X	X				
1	8000-324	Compressor									X			
1	8000-325	Compressor										X		
1	8000-326	Compressor											X	X
2	S900-320	Blower Assembly	X	X		X	X	X		X				
2	S900-321	Blower Assembly			X				X					
2	S900-185	Blower Assembly									X	X		X
2	S900-186	Blower Assembly											X	
3	8200-004	Fan Motor Mount	X	X	X	X	X	X	X	X	X	X	X	X
4	5151-027	Fan Blade	X	X	X	X	X	X	X	X	X	X	X	X
5	8105-030	Condenser Motor			X				X				X	
5	8105-039	Condenser Motor	X	X		X	X	X		X	X	X		X
6	5051-179BX	Condenser Coil	X	X	X	X	X	X	X					
6	5051-180BX	Condenser Coil									X	X	X	X
7	800-0420	Distributor Assembly	X	X	X	X								
7	800-0422	Distributor Assembly					X	X	X					
7	800-0423	Distributor Assembly									X	X	X	X
8	917-0207BX	Evaporator Coil					X	X	X	X				
8	917-0208BX	Evaporator Coil									X	X	X	X
8	917-0206BX	Evaporator Coil	X	X	X	X								
9	7004-016	Air Filter 1" Throw-Away	X	X	X	X	X	X	X	X	X	X	X	X
9	7003-030	Air Filter 1" Washable	X	X	X	X	X	X	X	X	X	X	X	X
9	7004-027	Air Filter 2" Pleated	X	X	X	X	X	X	X	X	X	X	X	X
10	1171-022	1/4 Turn Fastener	X	X	X	X	X	X	X	X	X	X	X	X
11	1171-024	1/4 Turn Retainer	X	X	X	X	X	X	X	X	X	X	X	X
12	1171-023	1/4 Receptacle	X	X	X	X	X	X	X	X	X	X	X	X
NS	5201-022	Filter Drier	X	X	X	X	X	X	X	X	X	X	X	X
NS	CMA-28	Low Ambient Control ①	X	X	X	X	X	X	X	X	X	X	X	X
NS	1804-0385	High Pressure Switch (Flare)	X	X	X	X	X	X	X	X	X	X	X	X
NS	1804-0386	Low Pressure Switch (Flare)	X	X	X	X	X	X	X	X	X	X	X	X
NS	5451-024	Tubing Isolation Grommet	2	2	2	2	2	2	2	2	2	2	2	2

① Optional on these models.

NS = Not shown

FUNCTIONAL COMPONENTS

Dwg No.	Part Number	Description	W70L2-A	W70L2-B	W70L2-C	W70L2-F
1	8000-403	Compressor	X			
1	8000-404	Compressor		X		
1	8000-405	Compressor			X	X
2	S900-185	Blower Assembly	X	X		X
2	S900-186	Blower Assembly			X	
3	8200-004	 Fan Motor Mount	X	X	X	X
4	5151-027	Fan Blade	X	X	X	X
5	8107-010	Condenser Motor			X	
5	8106-016	Condenser Motor	X	X		X
6	5051-180BX	Condenser Coil	X	X	X	X
7	800-0425	Distributor Assembly	X	X	X	X
8	917-0209BX	Evaporator Coil	X	X	X	X
9	7004-016	Air Filter 1" Throw-Away	X	X	X	X
9	7003-030	Air Filter 1" Washable	X	X	X	X
9	7004-027	Air Filter 2" Pleated	X	X	X	X
10	1171-022	1/4 Turn Fastener	X	X	X	X
11	1171-024	1/4 Turn Retainer	X	X	X	X
12	1171-023	1/4 Receptacle	X	X	X	X
NS	5201-022	Filter Drier	X	X	X	X
NS	CMA-28	Low Ambient Control (Flare) ①	X	X	X	X
NS	1804-0385	High Pressure Switch (Flare)	X	X	X	X
NS	1804-0386	Low Pressure Switch (Flare)	X	X	X	X
NS	5451-024	Tubing Isolation Grommet	2	2	2	2
NS	CMC-29	Freeze Thermostat Kit	X	X	X	X

① Optional on these models.

NS = Not shown

CONTROL PANEL

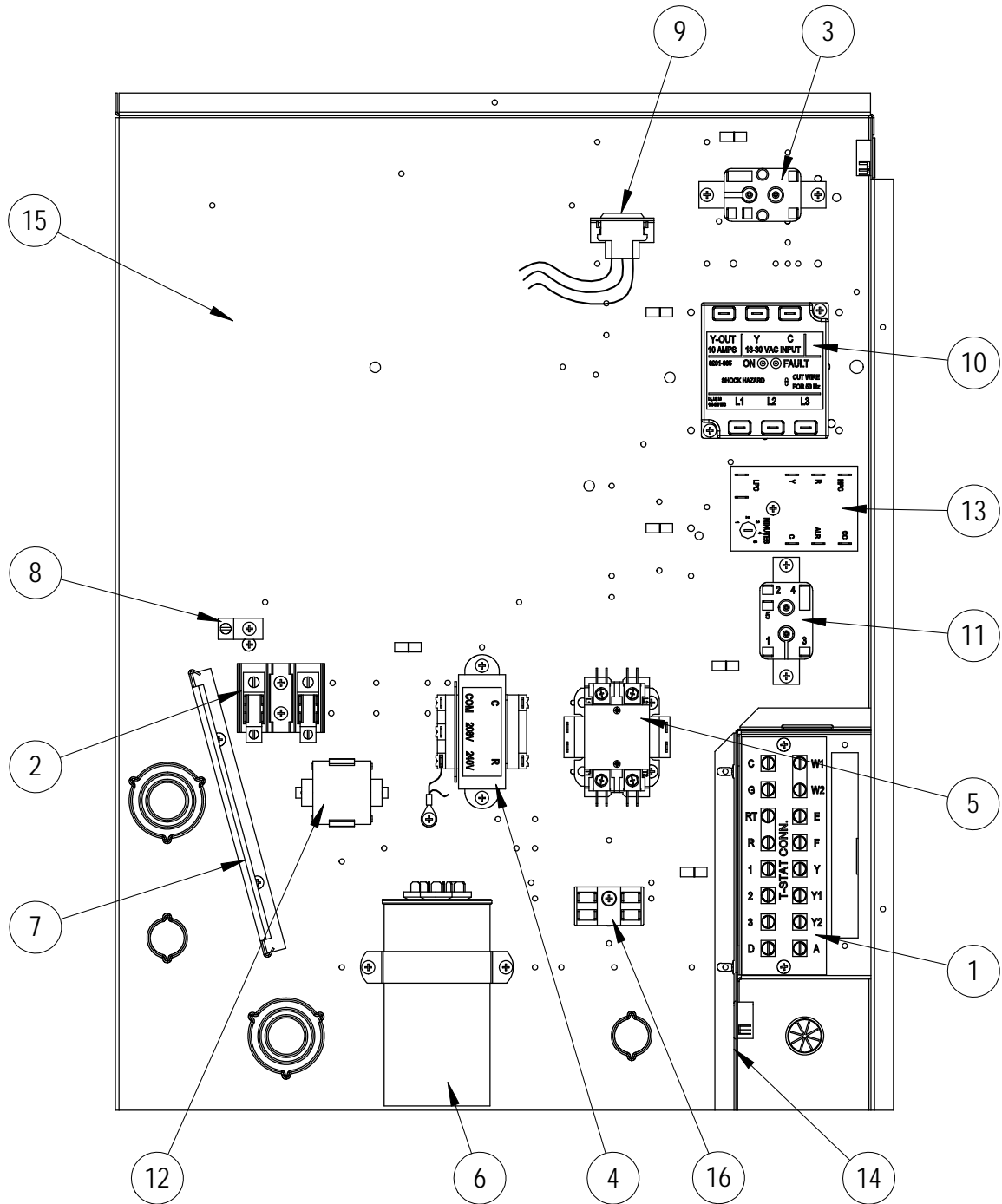

SEXP-662

CONTROL PANEL

Dwg No.	Part Number	Description	W42L2-A	W42L2-B	W42L2-C	W42L2-F	W48L2-A	W48L2-B	W48L2-C	W48L2-F	W60L2-A	W60L2-B	W60L2-C	W60L2-F
1	8607-034	Low Voltage Terminal Strip	X	X	X	X	X	X	X	X	X	X	X	X
2	8607-013	Terminal Block 2 Pole	X			2	X			2	X			2
2	8607-014	Terminal Block 3 Pole		X	X			X	X			X	X	
2	8607-015	Phenolic Insulator			X				X				X	
2	134-051	Terminal Block Barrier				2				2				2
3	8201-009	Blower Control Relay	X	X		X	X	X		X	X	X		X
3	8201-032	Blower Control Relay			X				X				X	
4	8407-034	Transformer	X	X		X	X	X		X	X	X		X
4	8407-042	Transformer			X				X				X	
5	8401-002	Compressor Contactor		X	X	X		X	X	X		X	X	X
5	8401-025	Compressor Contactor	X				X				X			
6	8552-079	Compressor Capacitor	X											
6	8552-005	Outdoor Motor Capacitor		X		X		X		X				
6	8552-026	Outdoor Motor Capacitor			X			X					X	
6	8552-059	Compressor Capacitor					X							
6	8552-089	Compressor Capacitor									X			
6	8552-004	Compressor Capacitor										X		X
7	135-130	Wire Shield	X	X	X	X	X	X	X	X	X	X	X	X
8	8611-006	Ground Terminal	X	X	X	X	X	X	X	X	X	X	X	X
9	3000-978	6 Pin Connector	X	X	X	X	X	X	X	X	X	X	X	X
10	8201-126	Phase Monitor		X	X	X		X	X	X		X	X	X
11	8201-062	Alarm Relay ①	X	X	X	X	X	X	X	X	X	X	X	X
12	8551-004	Start Device (PTCR) ①	X				X				X			
13	8201-148	Compressor Control Module	X	X	X	X	X	X	X	X	X	X	X	X
14	117Y333	Low Voltage Box	X	X	X	X	X	X	X	X	X	X	X	X
15	117Y340	Control Panel	X	X	X	X	X	X	X	X	X	X	X	X
16	8607-017	Terminal Block ①	X	X	X	X	X	X	X	X	X	X	X	X
NS	8615-040	Circuit Breaker 50A 2 Pole ②	X				X							
NS	8615-042	Circuit Breaker 35A 3 Pole ②		X				X						
NS	8615-067	Toggle Disconnect ②			X	X			X	X			X	X
NS	8615-044	Circuit Breaker 45A 3 Pole ②										X		
NS	8615-041	Circuit Breaker 60A 2 Pole ②									X			
NS	4095-163	Wiring Diagram	X				X				X			
NS	4095-255	Wiring Diagram		X				X				X		
NS	4095-357	Wiring Diagram			X				X				X	
NS	4095-635	Wiring Diagram				X				X				X

① Optional on these models.

② Circuit breakers listed are for units without electric heat "0Z" models. See Heater Replacement Parts Manual for units with electric heat.

NS = Not shown

CONTROL PANEL

Dwg No.	Part Number	Description	W70L2-A	W70L2-B	W70L2-C	W70L2-F
1	8607-034	Low Voltage Terminal Strip	X	X	X	X
2	8607-013	Terminal Block 2 Pole	X			2
2	8607-014	Terminal Block 3 Pole		X	X	
2	8607-015	Phenolic Insulator			X	
3	8201-009	Blower Control Relay	X	X		X
3	8201-032	Blower Control Relay			X	
4	8407-034	Transformer	X	X		X
4	8407-042	Transformer			X	
5	8401-002	Compressor Contactor		X	X	X
5	8401-025	Compressor Contactor	X			
6	8552-005	Outdoor Motor Capacitor			X	X
6	8552-082	Compressor Capacitor	X			
6	8552-004	Compressor Capacitor		X		
7	135-130	Wire Shield	X	X	X	X
8	8611-006	Ground Terminal	X	X	X	X
9	3000-1017	6 Pin Connector	X	X	X	X
10	8201-126	Phase Monitor		X	X	X
11	8201-062	Alarm Relay ①	X	X	X	X
12	8551-004	Start Device (PTCR) ①	X			
13	8201-148	Compressor Control Module	X	X	X	X
14	117Y333	Low Voltage Box	X	X	X	X
15	117Y340	Control Panel	X	X	X	X
16	8607-017	Terminal Block ①	X	X	X	X
NS	8615-067	Toggle Disconnect ②			X	X
NS	8615-045	Circuit Breaker 50A 3 Pole ②		X		
NS	8615-041	Circuit Breaker 60A 2 Pole ②	X			
NS	4095-165	Wiring Diagram	X			
NS	4095-257	Wiring Diagram		X		
NS	4095-358	Wiring Diagram			X	
NS	4095-259	Wiring Diagram				X

① Optional on these models.

② Circuit breakers listed are for units without electric heat "0Z" models. See Heater Replacement Parts Manual for units with electric heat.

NS = Not shown

BLOWER ASSEMBLY

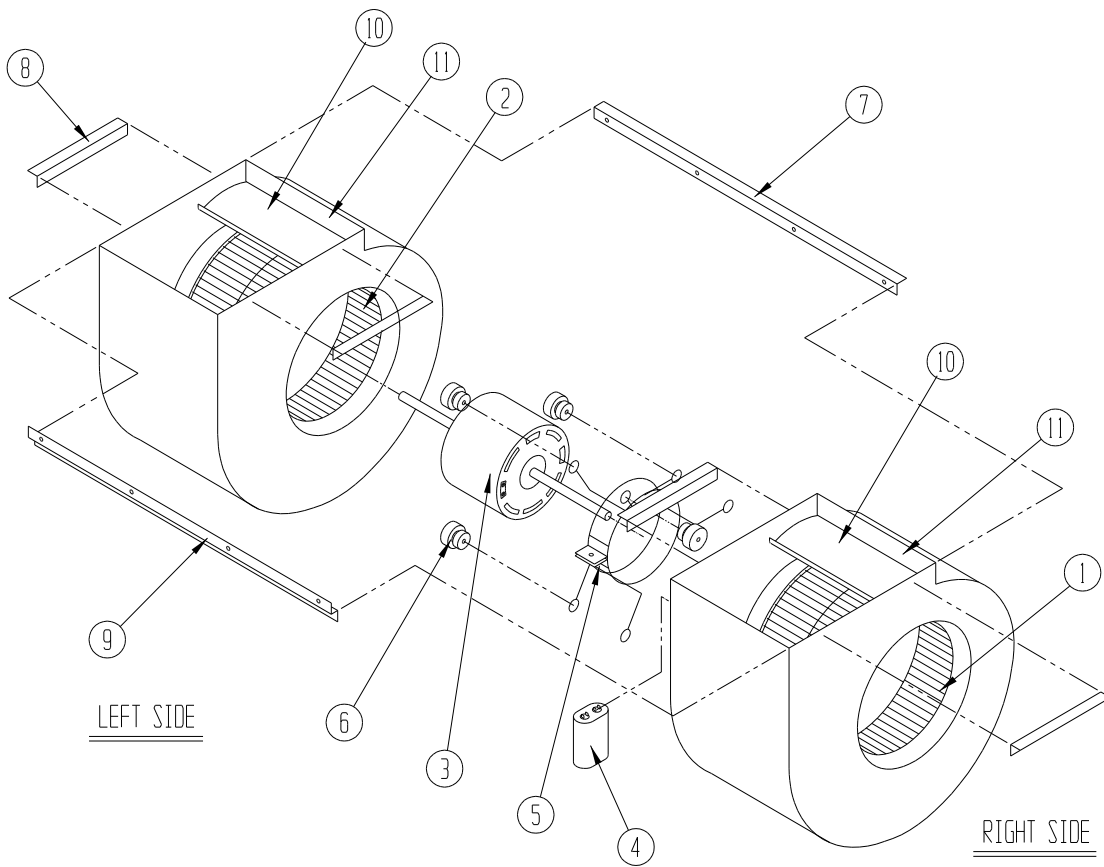

SEXP-178

Dwg No.	Part Number	Description	900-320	900-321	900-185	900-186
1	5152-011	10 Inch Wheel (CW)			X	X
1	5152-057	9 Inch Wheel (CW)	X	X		
2	5152-012	10 Inch Wheel (CW)	X	X	X	X
2	5152-058	9 Inch Wheel (CW)	X	X		
3	8105-061	Blower Motor (230/208)	X			
3	8105-062	Blower Motor (460)		X		
3	8106-046	Blower Motor (230/208)			X	
3	8106-025	Blower Motor (460)				X
4	8552-091	Capacitor	X	X		
4	8552-005	Capacitor			X	X
5	8200-040	Motor Mount	X	X	X	X
6	5451-011	Grommets	6	6	6	6
7	105-881	Back Brace	X	X	X	X
8	105-880	Side Angle	4	4	4	4
9	103-389	Front Brace	X	X	X	X
10	151-101	Housing	2	2	2	2
11	144-166	Diffuser	2	2	2	2