REPLACEMENT PARTS MANUAL

WALL MOUNTED PACKAGE AIR CONDITIONER

Models: W17A2, W18A2, W24A2

General Notes

- Revised and/or additional pages may be issued from time to time.
- A complete and current manual consists of pages shown in the following contents section.

Important

- Contact the installing and/or local Bard distributor for all parts requirements. Make sure you have the complete model and serial number available from the unit rating plates.

Contents

Description	Page
Cabinet Components	
♦ Exploded View	2
♦ Usage List	3
Functional Components	
♦ Exploded View	4
♦ Usage List	5
Control Panel	
♦ Exploded View	6
♦ Usage List	7
Blower Assembly	
♦ Exploded View	8
♦ Usage List	8



Climate Control Solutions

Bard Manufacturing Company, Inc.
Bryan, Ohio 43506
Since 1914...Moving ahead, just as planned.

Manual: 2110-1407D
Supersedes: 2110-1407C
File: Tab 16
Date: 06-24-14

CABINET COMPONENTS

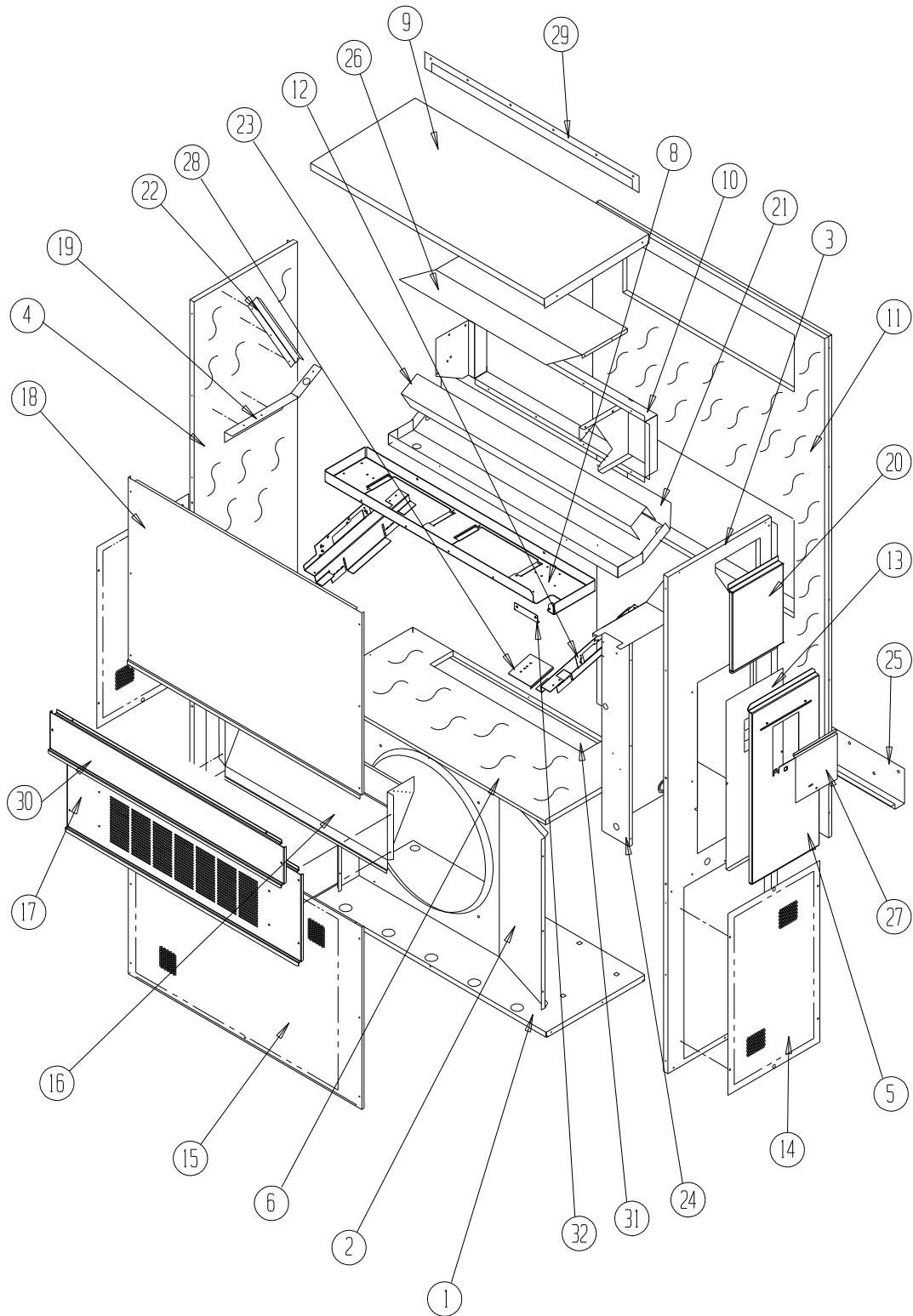

SEXP-684

CABINET COMPONENTS

Dwg No.	Part Number	Description	W1718A2-A	W24A2-A, B, D	W24A2-F, C
1	127-467	Lower Base	X	X	X
1	127-469 ②	Lower Base	X	X	X
2	125-023	Fan Shroud	X	X	X
2	125-056 ②	Fan Shroud	X	X	X
3	S501-684-* ①	Right Side	X	X	X
3	S501-720 ②	Right Side	X	X	X
4	S501-711-* ①	Left Side	X	X	X
4	S501-721 ②	Left Side	X	X	X
5	S533-228 ①	Control Panel Cover (Outer)	X	X	X
5	S533-235 ②	Control Panel Cover (Outer)	X	X	X
6	S521X479	Condenser Partition	X	X	X
8	121X480	Blower Partition	X	X	X
9	S507-311-* ①	Top	X	X	X
9	S507-317 ②	Top	X	X	X
10	S111X032	Outlet Air Frame Assembly	X	X	X
11	S508-097	Back	X	X	X
11	S508-220 ②	Back	X	X	X
12	113X480	Filter Bracket	2	2	2
13	S132-104	Control Panel Cover (Inner)	X	X	
13	S132-172	Control Panel Cover (Inner)			X
14	118-056-* ①	Side Grille	2	2	2
14	118-067 ②	Side Grille	2	2	2
15	118-050-* ①	Condenser Grille	X	X	X
15	118-076 ②	Condenser Grille	X	X	X
16	BFAD-2	Fresh Air Damper Assembly	X	X	X
17	S553-537-* ①	Vent Option Door	X	X	X
17	S553-539 ①	Vent Option Door with ERV	X	X	X
17	S553-547 ②	Vent Option Door	X	X	X
18	S514-240-* ①	Upper Front	X	X	X
18	S514-236 ②	Upper Front	X	X	X
19	105X850	Side Support	X	X	X
20	S543-175-* ①	Right Side Cover Plate (Outer)	X	X	X
20	S543-185 ②	Right Side Cover Plate (Outer)	X	X	X
21	S123-126	Drain Pan	X	X	X
21	S123-140 ②	Drain Pan	X	X	X
22	147-044	Evaporator Support	X	X	X
23	137-694	Bottom Evaporator Fill	X	X	X
24	Control Panel Assembly	See Control Panel Assy. Drawing & Parts List Assy.	X	X	X
25	113-140	Bottom Mounting Bracket	X	X	X
26	135X127	Heat Shield	X	X	X
27	S153-218 ①	Disconnect Access Door	X	X	X
27	S153-405 ②	Disconnect Access Door	X	X	X
28	137-259	Fill Plate	X	X	X
29	113-141-* ①	Top Rain Flashing	X	X	X
29	113-361 ②	Top Rain Flashing	X	X	X
30	S553-538-* ①	Filter Door	X	X	X
30	S553-551 ②	Filter Door	X	X	X
31	S536-176	Cond. Partition Block Off Plate	X	X	X
32	105-1302	Grommet Retainer	X	X	X

① Exterior cabinet parts are manufactured with various paint color options. To ensure that you receive the proper paint color, you must include the complete model and serial number of the unit for which cabinet parts are being ordered.

② Note: Exterior cabinet parts are manufactured from stainless steel Code "S"

FUNCTIONAL COMPONENTS

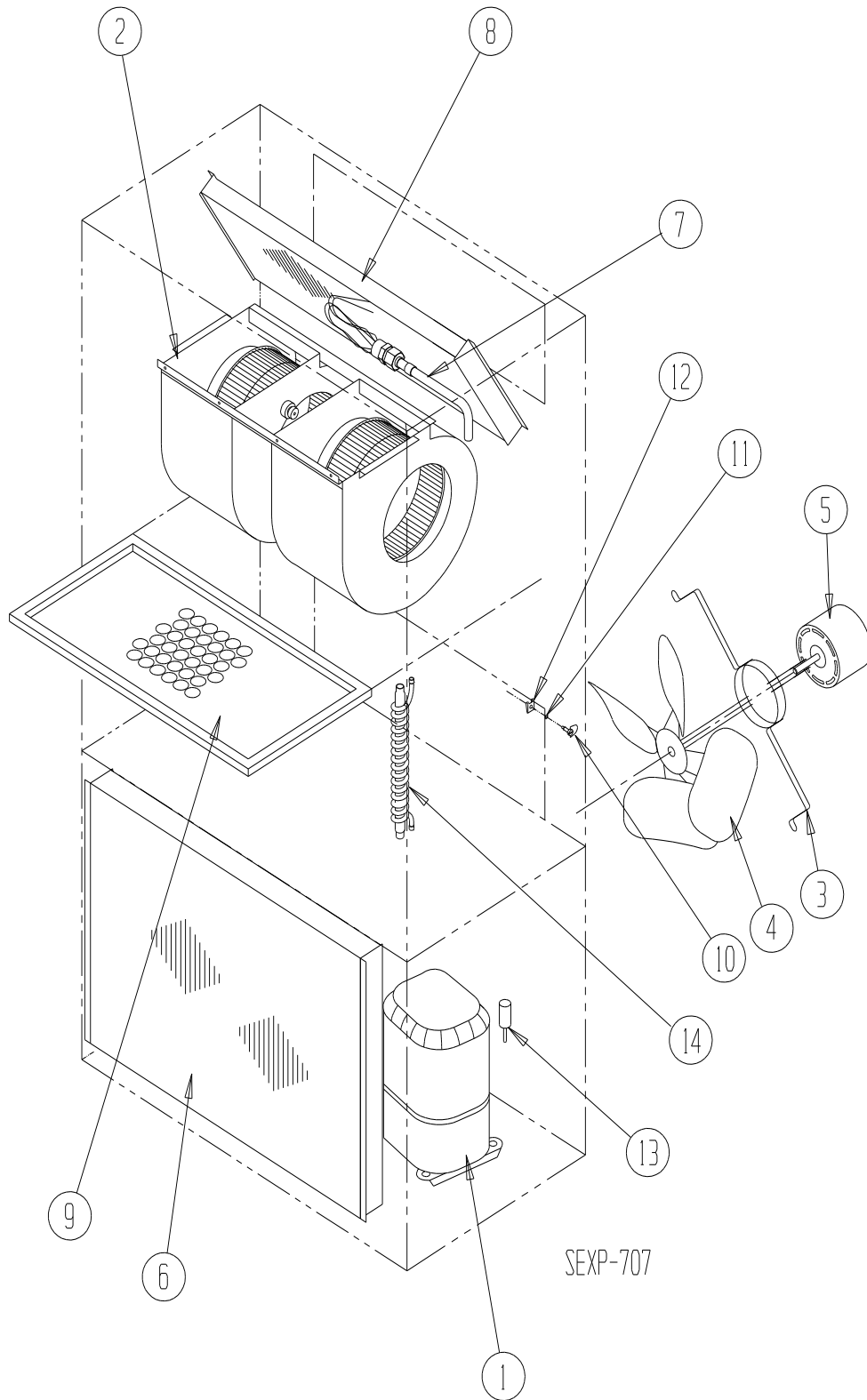

FUNCTIONAL COMPONENTS

Dwg No.	Part Number	Description	W17A2-A	W18A2-A	W24A2-A	W24A2-B	W24A2-C	W24A2-D	W24A2-F
1	8000-313	Compressor	X	X					
1	8000-314	Compressor			X				
1	8000-315	Compressor				X			
1	8000-316	Compressor					X		X
1	8000-317	Compressor						X	
2	S900-326	Blower Assembly			X	X		X	X
2	S900-327	Blower Assembly					X		
2	S900-291	Blower Assembly	X	X					
3	8200-001	Fan Motor Mount	X	X	X	X	X	X	X
4	5151-033	Fan Blade	X	X	X	X		X	X
4	5151-046	Fan Blade					X		
5	8103-016	Condenser Motor	X	X	X	X		X	X
5	8103-020	Condenser Motor					X		
6	5051-184BX	Condenser Coil	X	X					
6	5051-185BX	Condenser Coil			X	X	X	X	X
7	800-0427	Distributor Assembly		X					
7	800-0428	Distributor Assembly			X	X	X	X	X
7	800-0437	Distributor Assembly	X						
8	917-0218BX	Evaporator Coil with Distributor Assembly	X						
8	917-0219BX	Evaporator Coil with Distributor Assembly		X					
8	917-0220BX	Evaporator Coil with Distributor Assembly			X	X	X	X	X
9	7004-011	Air Filter 1" Throw-Away	X	X	X	X	X	X	X
9	7003-032	Air Filter 1" Washable ①	X	X	X	X	X	X	X
9	7004-025	Air Filter 2" Pleated ①	X	X	X	X	X	X	X
10	1171-022	1/4" Turn Fastener	X	X	X	X	X	X	X
11	1171-024	1/4" Turn Retainer	X	X	X	X	X	X	X
12	1171-023	1/4" Receptacle	X	X	X	X	X	X	X
13	1804-0385	High Pressure Switch (Flare)	X	X	X	X	X	X	X
13	1804-0386	Low Pressure Switch (Flare)	X	X	X	X	X	X	X
14	5204-001	Subcooling Heat Exchanger	X						
NS	CMA-28	Low Ambient Control (Flare) ①			X	X	X	X	X
NS	5201-021	Filter Drier	X	X	X	X	X	X	X

NS – Not Shown

① – Optional on these models

CONTROL PANEL

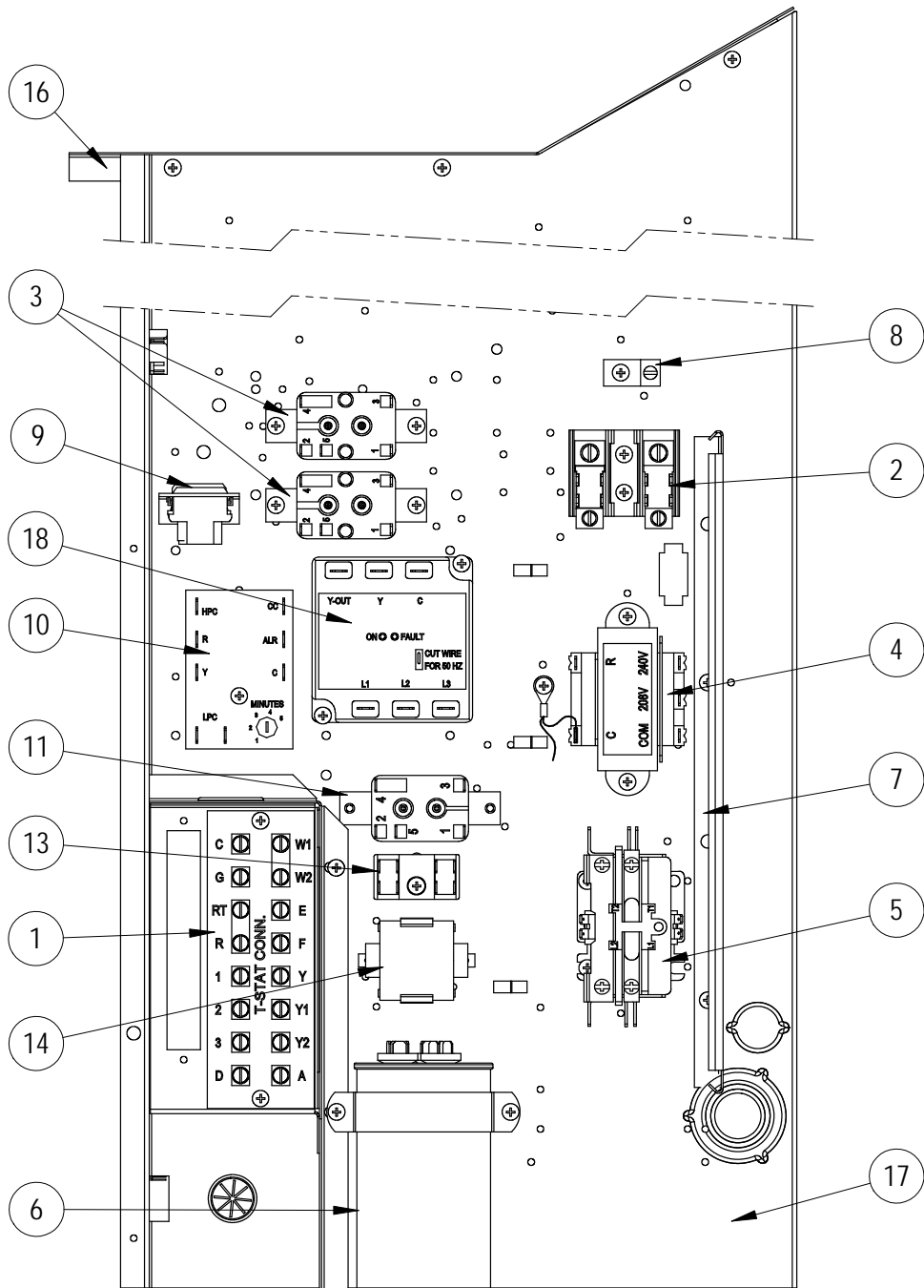

SEXP-685

CONTROL PANEL

Dwg No.	Part Number	Description	W17/18A2-A	W24A2-A	W24A2-B	W24A2-C	W24A2-D	W24A2-F
1	8607-034	Low Voltage Terminal Strip	X	X	X	X	X	X
2	8607-013	Terminal Block 2 Pole	X	X			X	2
2	8607-014	Terminal Block 3 Pole			X	X		
3	8201-009	Blower Control Relay	2	X	X		X	X
3	8201-032	Blower Control Relay				X		
4	8407-034	Transformer	X	X	X		X	X
4	8407-042	Transformer				X		
5	8401-007	Compressor Contactor	X	X			X	
5	8401-002	Compressor Contactor			X	X		X
6	8552-046	Compressor Capacitor	X					
6	8552-051	Compressor Capacitor		X			X	
6	8552-002	Outdoor Motor Capacitor			X	X		X
7	135-122	Wire Shield	X	X	X	X	X	X
8	8611-006	Ground Terminal	X	X	X	X	X	X
9	3000-968	6 Pin Connector	X	X	X	X	X	X
10	8201-088	Compressor Control Module (Opt.)	X	X	X	X	X	X
11	8201-062	Alarm Relay (Optional)	X	X	X	X	X	X
13	8607-017	Terminal Block (Optional)	X	X	X	X	X	X
14	8551-004	Start Device (PTCR) (Optional)	X	X			X	
16	117X137	Control Panel Top	X	X	X	X	X	X
17	117X123	Control Panel	X	X	X	X	X	X
18	8201-126	Phase Monitor			X	X		X
NS	8615-035	Circuit Breaker 20A 2 Pole (Opt.) ①	X					X
NS	8615-036	Circuit Breaker 25A 2 Pole (Opt.) ①		X				
NS	8615-067	Toggle Disconnect (Optional) ①				X		X
NS	8615-056	Circuit Breaker 15A 3 Pole (Opt.) ①			X			
NS	4095-170	Wiring Diagram	X					
NS	4095-169	Wiring Diagram		X			X	
NS	4095-260	Wiring Diagram			X			
NS	4095-360	Wiring Diagram				X		
NS	4095-636	Wiring Diagram						X

NS = Not Shown

① Circuit breakers listed are for units without electric heat, "0Z" models. Hot gas bypass models not available without electric heat. See Heater Replacement Parts Manual for units with electric heat.

BLOWER ASSEMBLY

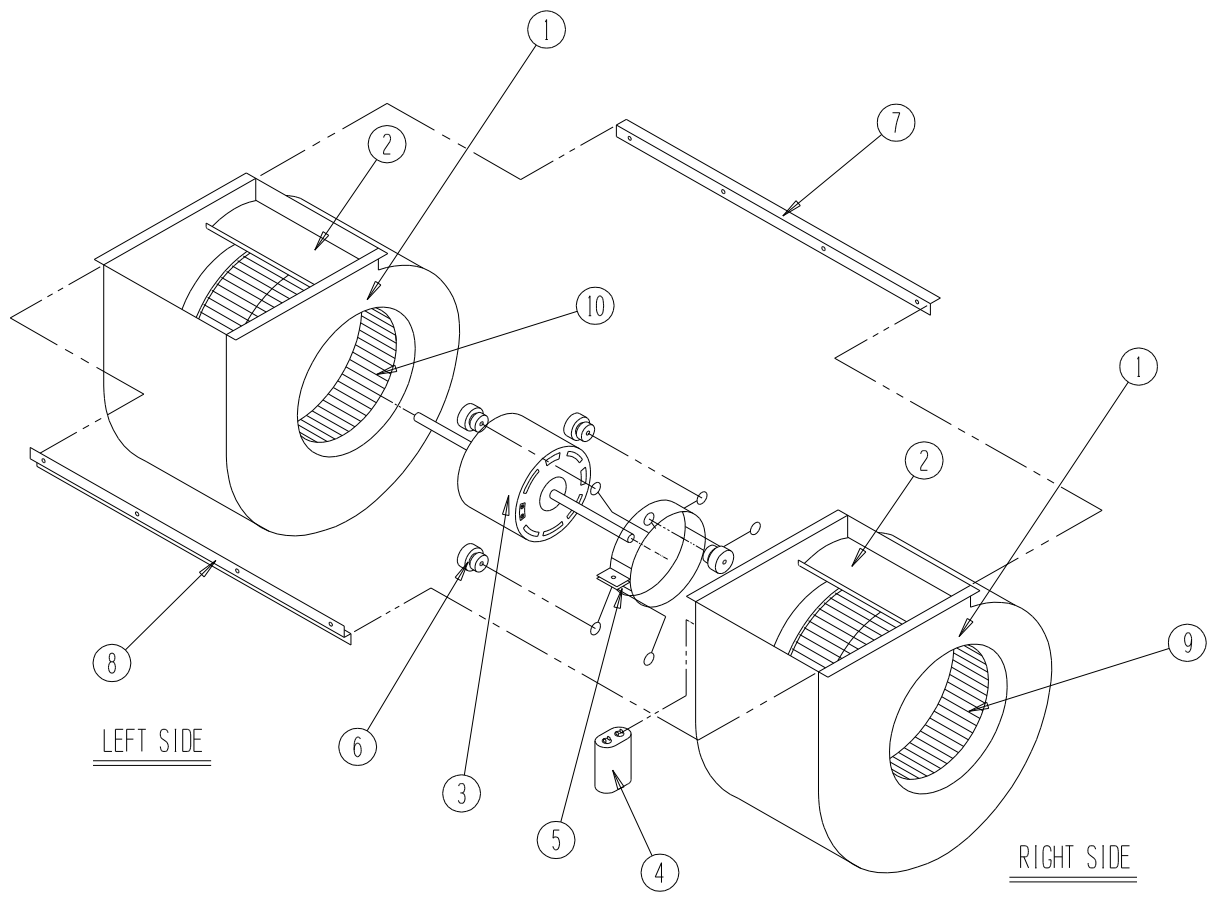

SEXP-346

Dwg No.	Part Number	Description	S900-326	S900-327	S900-291
1	151-115	Housing	2	2	2
2	144-183	Cutoff	X	X	X
3	8102-016	Blower Motor (230/208)	X		
3	8102-017	Blower Motor (460)		X	
3	8102-014	Blower Motor (230/208)			X
4	8552-002	Capacitor			X
4	8552-004	Capacitor	X	X	
5	8200-031	Motor Mount	X	X	X
6	5451-011	Grommets	6	6	6
7	105-1061	Back Brace	X	X	X
8	103-435	Front Brace	X	X	X
9	5152-092	Wheel 9-6 CW	X	X	X
10	5152-093	Wheel 9-6 CCW	X	X	X