REPLACEMENT PARTS MANUAL

WALL-MOUNTED PACKAGED AIR CONDITONER

Models:

W30L2-A	W36L2-A
W30L2-B	W36L2-B
W30L2-C	W36L2-C
	W36L2-F

Contents

Description	Page
Cabinet Components	
♦ Exploded View	2
♦ Usage List	3
Functional Components	
♦ Exploded View	4
♦ Usage List	5
Control Panel	
♦ Layout View	6
♦ Usage List	7
Blower Assembly	
♦ Exploded View	8
♦ Usage List	8

General Notes

- Revised and/or additional pages may be issued from time to time.
- A complete and current manual consists of pages shown in the following contents section.

Important

- Contact the installing and/or local Bard distributor for all parts requirements. Make sure to have the complete model and serial number available from the unit rating plates.



Climate Control Solutions

Bard Manufacturing Company, Inc.
Bryan, Ohio 43506
www.bardhvac.com

Manual: 2110-1410E
Supersedes: 2110-1410D
Date: 6-19-19

CABINET COMPONENTS

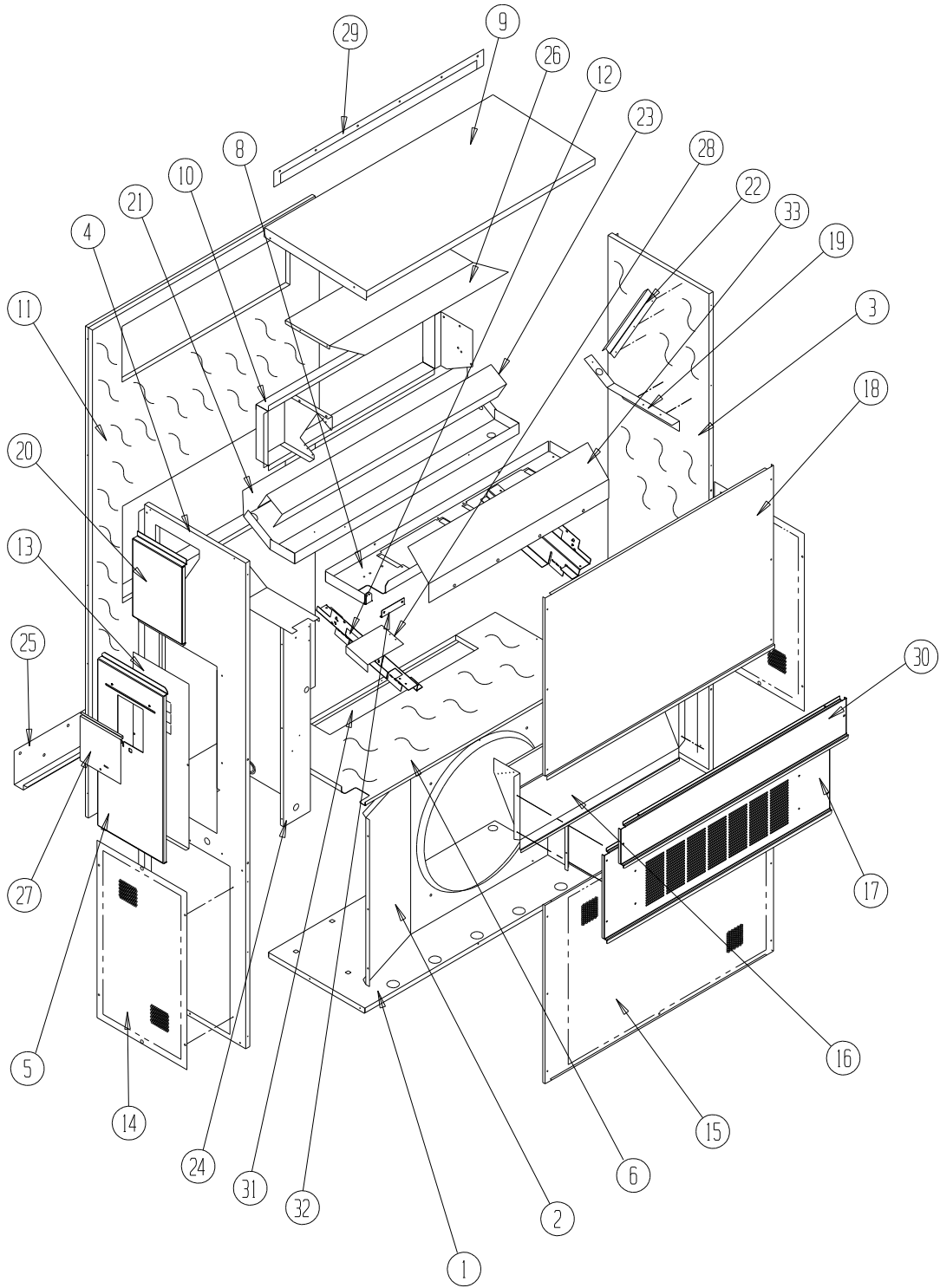

SEXP-690

CABINET COMPONENTS

Dwg No.	Part Number	Description	W30L2-A, B	W30L2-C	W36L2-A, B	W36L2-C	W36L2-F
1	S127-472	Lower Base	X	X	X	X	X
1	S127-474 ②	Lower Base	X	X	X	X	X
2	125-022	Fan Shroud	X	X	X	X	X
2	125-057 ②	Fan Shroud	X	X	X	X	X
3	S501-710-* ①	Right Side	X	X	X	X	X
3	S501-724 ②	Right Side	X	X	X	X	X
4	S501-685-* ①	Left Side	X	X	X	X	X
4	S501-725 ②	Left Side	X	X	X	X	X
5	S533-228 ①	Control Panel Cover (Outer)	X	X	X	X	X
5	S533-235 ②	Control Panel Cover (Outer)	X	X	X	X	X
6	S521Y466	Condenser Partition	X	X	X	X	X
8	121Y467	Blower Partition	X	X	X	X	X
9	S507-308-* ①	Top	X	X	X	X	X
9	S507-319 ②	Top	X	X	X	X	X
10	S111Y030	Outlet Air Frame Assembly	X	X	X	X	X
11	S508-088	Back	X	X	X	X	X
11	S508-222 ②	Back	X	X	X	X	X
12	113Y480	Filter Bracket	2	2	2	2	2
13	S132-104	Control Panel Cover (Inner)	X		X		
13	S132-172	Control Panel Cover (Inner)		X		X	X
14	118-056-* ①	Side Grille	2	2	2	2	2
14	118-067 ②	Side Grille	2	2	2	2	2
15	118-047-* ①	Condenser Grille	X	X	X	X	X
15	118-075 ②	Condenser Grille	X	X	X	X	X
16	BFAD-3	Fresh Air Damper Assembly	X	X	X	X	X
17	S553-523-* ①	Vent Option Door	X	X	X	X	X
17	S553-549 ②	Vent Option Door	X	X	X	X	X
18	S514-241-* ①	Upper Front	X	X	X	X	X
18	S514-238 ②	Upper Front	X	X	X	X	X
19	105Y850	Side Support	X	X	X	X	X
20	S543-175-* ①	Right Side Cover Plate (Outer)	X	X	X	X	X
20	S543-185 ②	Right Side Cover Plate (Outer)	X	X	X	X	X
21	S123-130	Drain Pan	X	X	X	X	X
21	S123-143 ②	Drain Pan	X	X	X	X	X
22	147-044	Evaporator Support	X	X	X	X	X
23	137-685	Bottom Evaporator Fill	X	X	X	X	X
24	Control Panel Assembly	See Control Panel Assy. Drawing & Parts List Assy.	X	X	X	X	X
25	113-140	Bottom Mounting Bracket	X	X	X	X	X
26	135Y123	Heat Shield	X	X	X	X	X
27	S153-218 ①	Disconnect Access Door	X	X	X	X	X
27	S153-405 ②	Disconnect Access Door	X	X	X	X	X
28	137-259	Fill Plate	X	X	X	X	X
29	113-149-* ①	Top Rain Flashing	X	X	X	X	X
29	113-360 ②	Top Rain Flashing	X	X	X	X	X
30	S553-524-* ①	Filter Door	X	X	X	X	X
30	S553-553 ②	Filter Door	X	X	X	X	X
31	S536-498	Cond. Partition Block Off Plate	X	X	X	X	X
32	105-1302	Grommet Retainer	X	X	X	X	X
33	135-329	Air Baffle	X	X	X	X	X

① Exterior cabinet parts are manufactured with various paint color options. To ensure the proper paint color is received, reference the following codes: Beige -X, White -1, Buckeye Gray -4, Desert Brown -5, Dark Bronze -8

② Exterior cabinet parts are manufactured from stainless steel Code "S"

FUNCTIONAL COMPONENTS

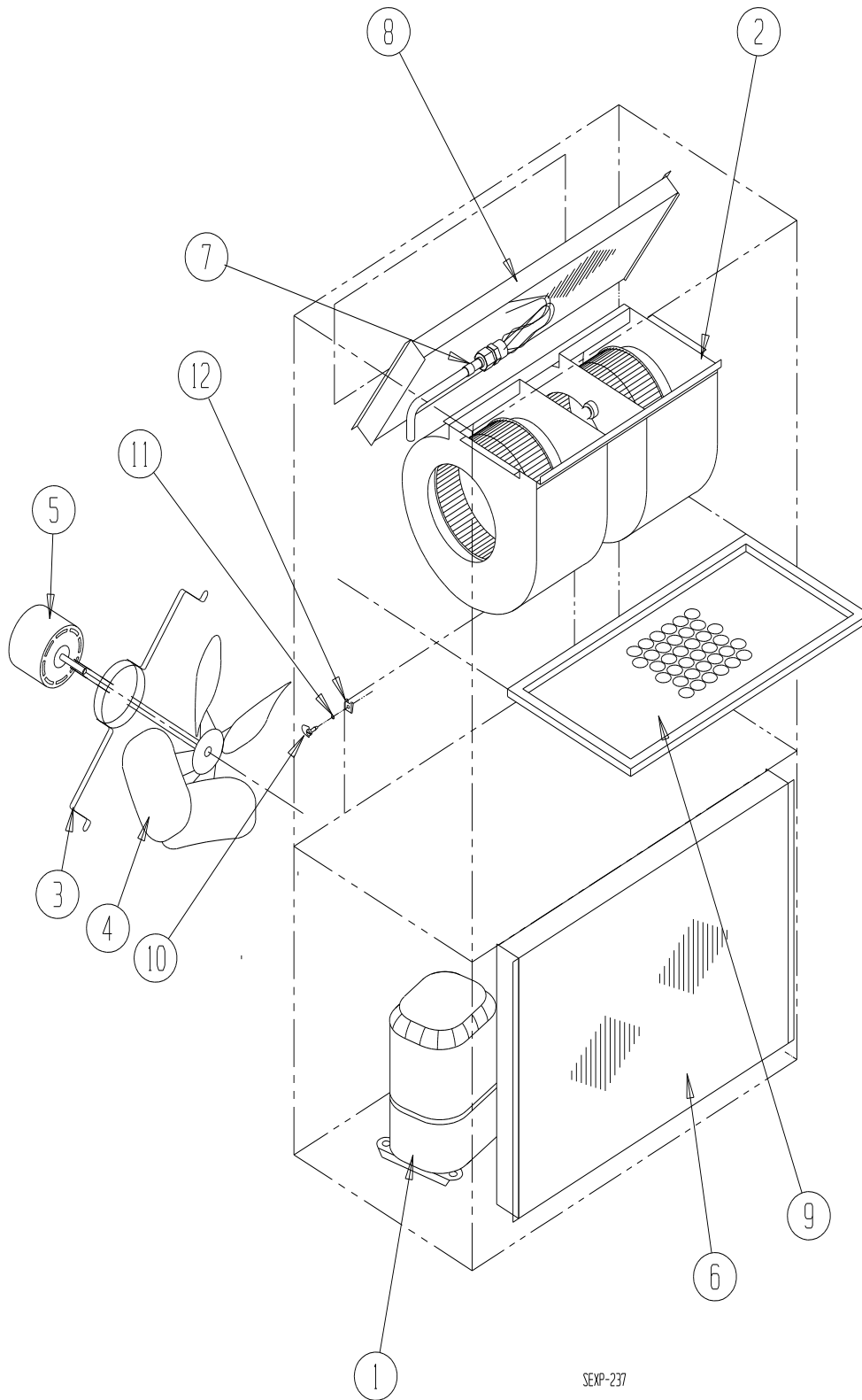

SEXP-237

FUNCTIONAL COMPONENTS

Dwg No.	Part Number	Description	W30L2-A	W30L2-B	W30L2-C	W36L2-A	W36L2-B	W36L2-C	W36A2-F
1	8000-298	Compressor	X						
1	8000-299	Compressor		X					
1	8000-300	Compressor			X				
1	8000-309	Compressor				X			
1	8000-310	Compressor					X		
1	8000-311	Compressor						X	X
2	S900-231	Blower Assembly	X	X		X	X		X
2	S900-232	Blower Assembly			X			X	
3	8200-001	Fan Motor Mount	X	X	X	X	X	X	X
4	5151-045	Fan Blade	X	X	X	X	X	X	X
5	8103-029	Condenser Motor	X	X		X	X		X
5	8103-030	Condenser Motor			X			X	
6	5051-181BX	Condenser Coil	X	X	X				
6	5051-182BX	Condenser Coil				X	X	X	X
7	800-0430	Distributor Assembly				X	X	X	X
7	800-0429	Distributor Assembly	X	X	X				
8	917-0224BX	Evaporator Coil w/Distributor Assy.	X	X	X				
8	917-0225BX	Evaporator Coil w/Distributor Assy.				X	X	X	X
9	7004-019	Air Filter 1" Throw-Away	X	X	X	X	X	X	X
9	7003-031	Air Filter 1" Washable ①	X	X	X	X	X	X	X
9	7004-026	Air Filter 2" Pleated ①	X	X	X	X	X	X	X
10	1171-022	1/4" Turn Fastener	X	X	X	X	X	X	X
11	1171-024	1/4" Turn Retainer	X	X	X	X	X	X	X
12	1171-023	1/4" Receptacle	X	X	X	X	X	X	X
NS	1804-0385	High Pressure Switch (Flare)	X	X	X	X	X	X	X
NS	1804-0386	Low Pressure Switch (Flare)	X	X	X	X	X	X	X
NS	CMA-28	Low Ambient Control (Flare) ①	X	X	X	X	X	X	X
NS	5201-021	Filter Drier	X	X	X	X	X	X	X
NS	6031-009	Coremax Valve Core	X	X	X	X	X	X	X

NS – Not Shown

① – Optional on these models

CONTROL PANEL

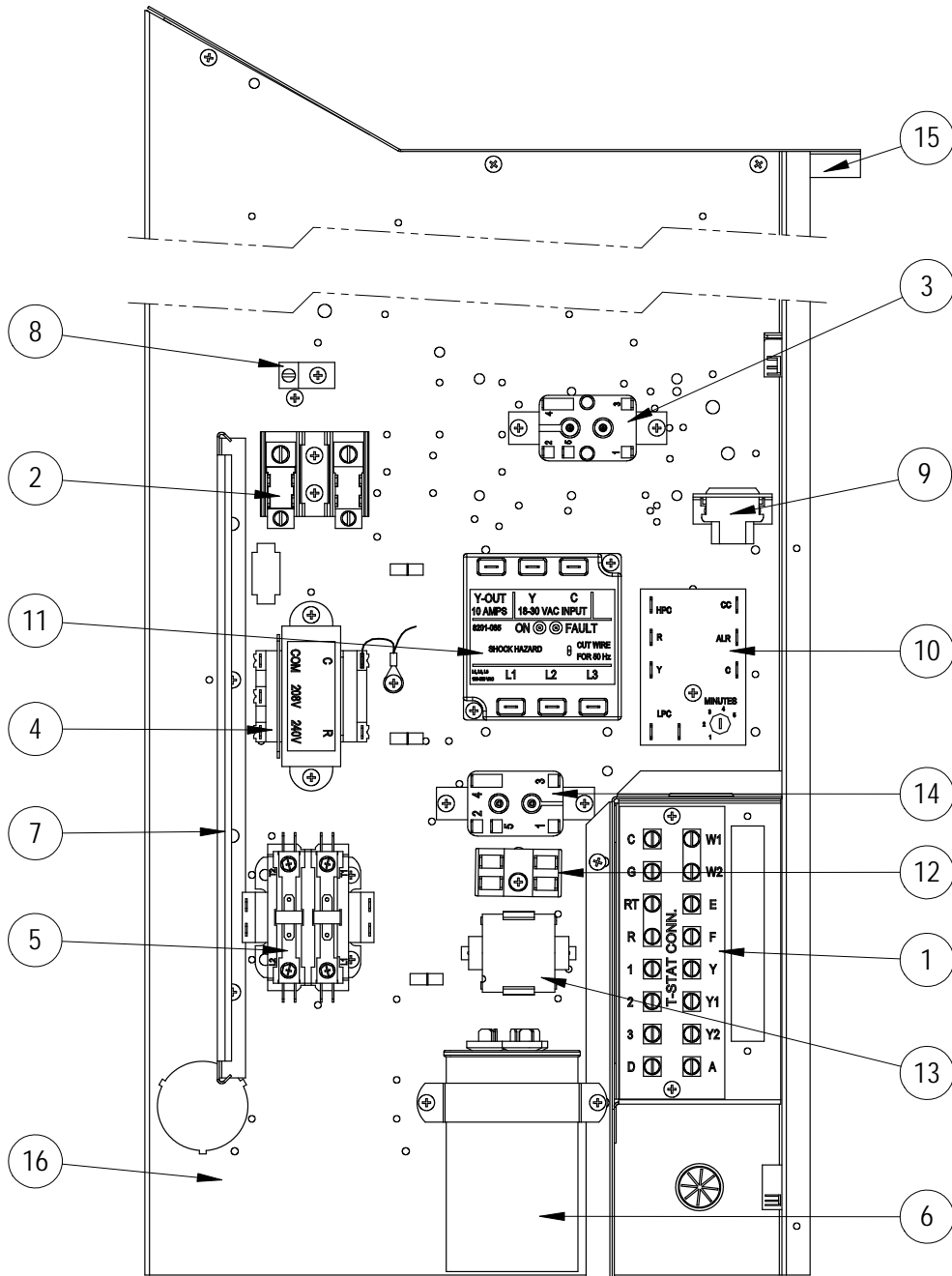

SEXP-691 A

CONTROL PANEL

Dwg No.	Part Number	Description	W30L2-A	W30L2-B	W30L2-C	W36L2-A	W36L2-B	W36L2-C	W36L2-F
1	8607-034	Low Voltage Terminal Strip	X	X	X	X	X	X	X
2	8607-013	Terminal Block 2 Pole	X			X			2
2	8607-014	Terminal Block 3 Pole		X			X	X	
2	8607-015	Phenolic Insulator			X			X	
2	134-051	Phenolic Insulator							2
3	8201-009	Blower Control Relay	X	X		X	X		X
3	8201-032	Blower Control Relay			X			X	
4	8407-068	Transformer	X	X		X	X		X
4	8407-069	Transformer			X			X	
5	8401-006	Compressor Contactor	X			X			
5	8401-002	Compressor Contactor		X	X		X	X	X
6	8552-052	Compressor Capacitor	X			X			
6	8552-002	Outdoor Motor Capacitor		X	X		X	X	X
7	135-122	Wire Shield	X	X	X	X	X	X	X
8	8611-006	Ground Terminal	X	X	X	X	X	X	X
9	3000-968	6 Pin Connector	X	X	X	X	X	X	X
10	8201-164	Compressor Control Module (Opt.)	X	X	X	X	X	X	X
11	8201-126	Phase Monitor		X	X		X	X	X
12	8607-017	Terminal Block (Optional)	X	X	X	X	X	X	X
13	8551-004	Start Device (PTCR) (Optional)	X	X	X	X	X	X	X
14	8201-062	Alarm Relay (Optional)	X	X	X	X	X	X	X
15	117Y137	Control Panel Top	X	X	X	X	X	X	X
16	117Y123	Control Panel	X	X	X	X	X	X	X
NS	8615-038	Circuit Breaker 35A 2 Pole (Opt.) ①	X			X			
NS	8615-054	Circuit Breaker 20A 3 Pole (Opt.) ①		X					
NS	8615-052	Circuit Breaker 30A 3 Pole (Opt.) ①					X		
NS	8615-067	Toggle Disconnect (Optional) ①			X			X	X
NS	4095-169	Wiring Diagram	X			X			
NS	4095-260	Wiring Diagram		X			X		
NS	4095-360	Wiring Diagram			X			X	
NS	4095-636	Wiring Diagram							X

NS = Not Shown

① Circuit breakers listed are for units without electric heat, "OZ" models. Hot gas bypass models not available without electric heat. See Heater Replacement Parts Manual for units with electric heat.

BLOWER ASSEMBLY

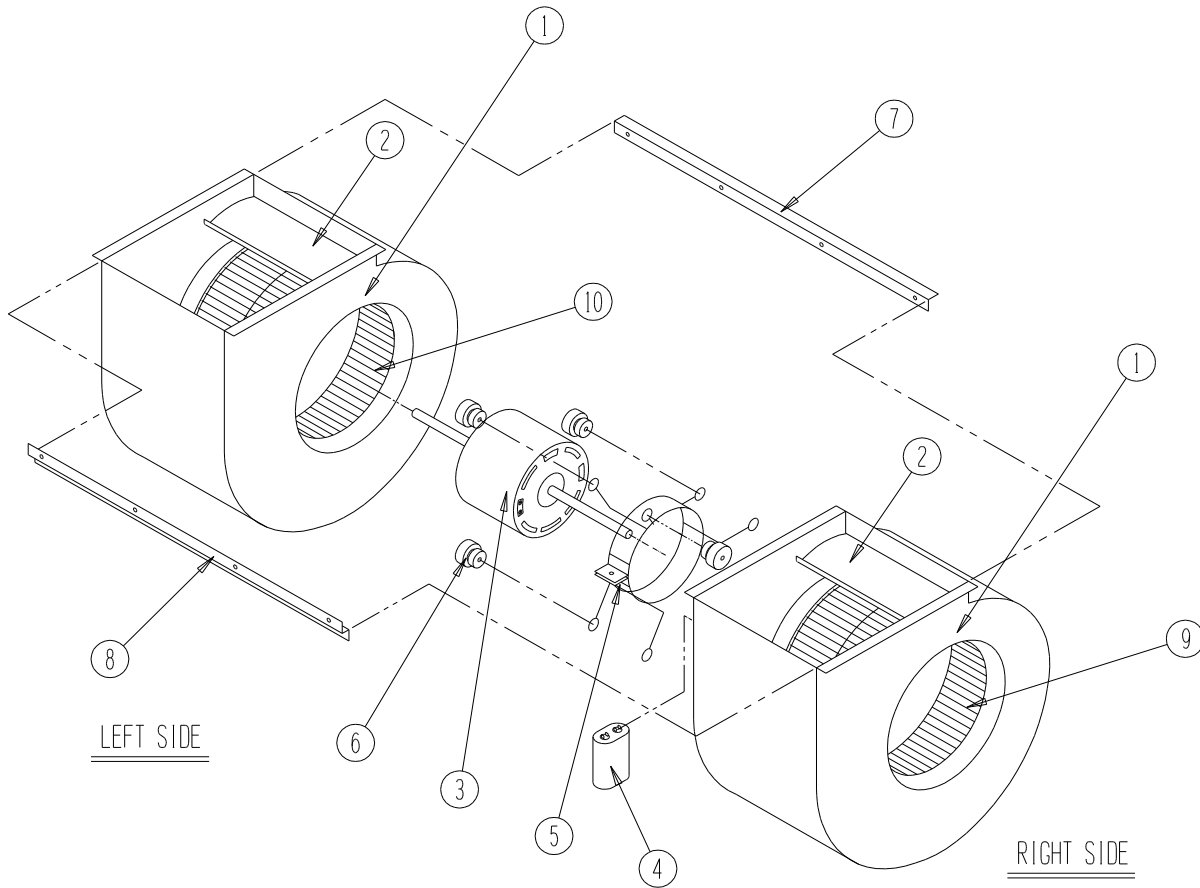

SEXP-346

Dwg No.	Part Number	Description	S900-231	S900-232
1	151-111	Housing	2	2
2	144-174	Diffuser	2	2
3	8105-029	Blower Motor (230/208)	X	
3	8105-033	Blower Motor (460)		X
4	8552-002	Capacitor	X	X
5	8200-031	Motor Mount	X	X
6	5451-011	Grommets	6	6
7	105-870	Back Brace	X	X
8	103-401	Front Brace	X	X
9	5152-090	Wheel CW	X	X
10	5152-091	Wheel CCW	X	X