REPLACEMENT PARTS MANUAL

WALL MOUNTED PACKAGE AIR CONDITIONER

Models:

J42A2-A J42L2-A J48A2-A J48L2-A J60A2-A J60L2-A J70A2-A J70L2-A
J42A2-B J42L2-B J48A2-B J48L2-B J60A2-B J60L2-B J70A2-B J70L2-B
J42A2-C J42L2-C J48A2-C J48L2-C J60A2-C J60L2-C J70A2-C J70L2-C

Contents

<u>Description</u>	<u>Page</u>	<u>Description</u>	<u>Page</u>
Cabinet Components – Right Hand Models		Blower Assembly	
♦ Exploded View	2	♦ Exploded View	14
♦ Usage List	3	♦ Usage List	14
Cabinet Components – Left Hand Models			
♦ Exploded View	4		
♦ Usage List	5		
Functional Components – Right Hand Models			
♦ Exploded View	6		
♦ Usage List	7		
Functional Components – Left Hand Models			
♦ Exploded View	8		
♦ Usage List	9		
Control Panel – Right Hand Models			
♦ Exploded View	10		
♦ Usage List	11		
Control Panel – Left Hand Models			
♦ Exploded View	12		
♦ Usage List	13		

General Notes

- Revised and/or additional pages may be issued from time to time.
- A complete and current manual consists of pages shown in the following contents section.

Important

- Contact the installing and/or local Bard distributor for all parts requirements. Make sure to have the complete model and serial number available from the unit rating plates.



Manual: 2110-1411E
Supersedes: 2110-1411D
Date: 3-8-16

CABINET COMPONENTS - RIGHT HAND MODELS

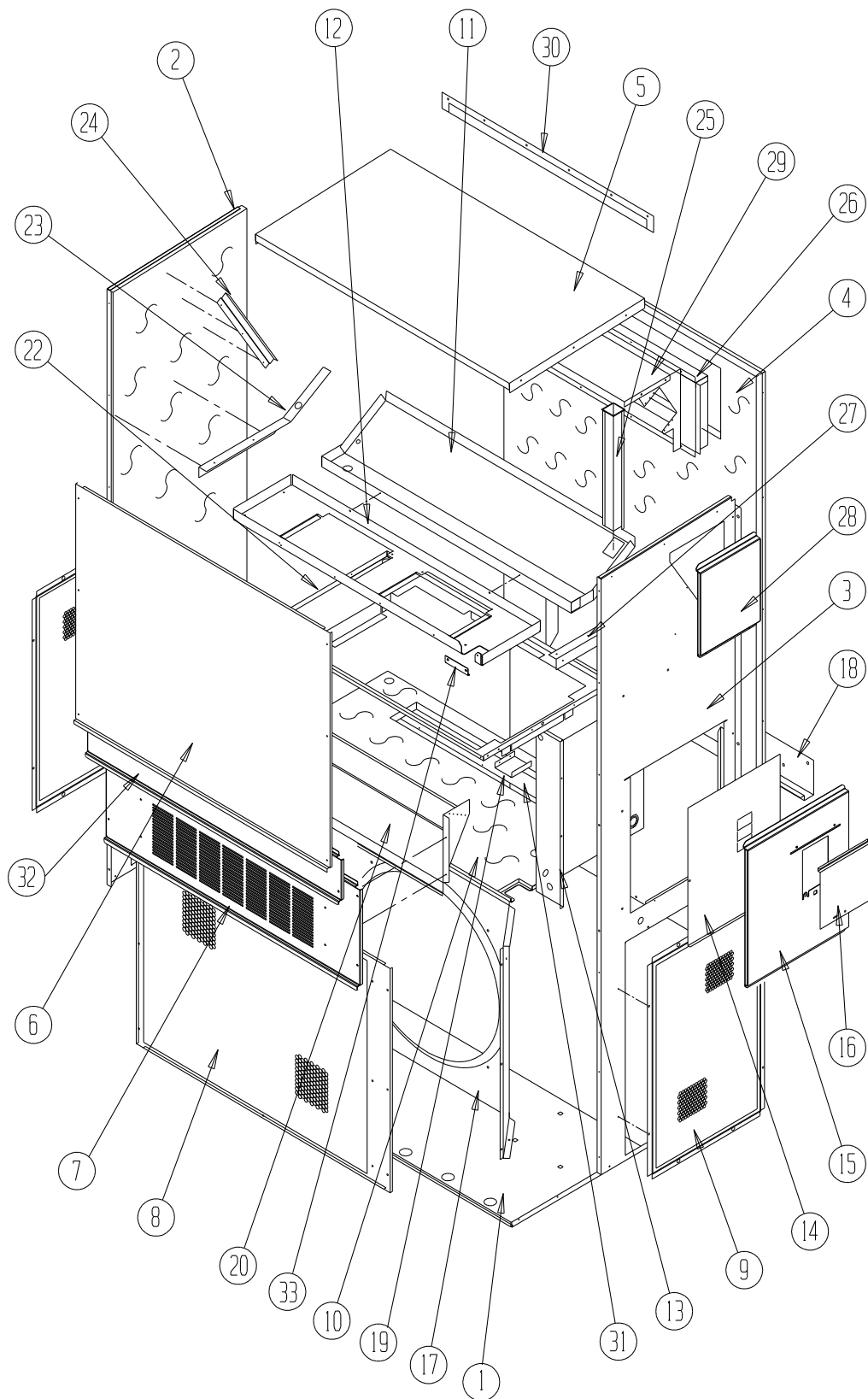

SEXP-658 A

CABINET COMPONENTS – RIGHT HAND MODELS

Dwg No.	Part Number	Description	J42A2-A, B	J42A2-C	J48A2-A, B	J48A2-C	J60A2-A, B	J60A2-C	J70A2-A, B	J70A2-C
1	127-425	Lower Base	X	X	X	X	X	X	X	X
2	S501-686-X	Left Side	X	X	X	X	X	X	X	X
3	S501-677-X	Right Side	X	X	X	X	X	X	X	X
4	S508-098	Back	X	X	X	X	X	X	X	X
5	S507-307-X	Top	X	X	X	X	X	X	X	X
6	S515-230-X	Upper Front	X	X	X	X	X	X	X	X
7	S553-522-X	Vent Option Door	X	X	X	X	X	X	X	X
7	S553-529-X	Vent Option Door/ERV	X	X	X	X	X	X	X	X
8	118-048-X	Condenser Grille	X	X	X	X	X	X	X	X
9	118-057-X	Side Grille	2	2	2	2	2	2	2	2
10	S521X462	Condenser Partition	X	X	X	X	X	X	X	X
11	S123-122	Drain Pan	X	X	X	X	X	X	X	X
12	121X463	Blower Partition	X	X	X	X	X	X	X	X
13	Control Panel Assy.	See Control Panel Assy. Drawing and Parts List	X	X	X	X	X	X	X	X
14	S132-114	Control Panel Cover (Inner)	X		X		X		X	
14	S132-171	Control Panel Cover (Inner)		X		X		X		X
15	S533-225-X	Control Panel Cover (Outer)	X	X	X	X	X	X	X	X
16	S153-218-X	Disconnect Access Door	X	X	X	X	X	X	X	X
17	125-024	Fan Shroud	X	X	X	X	X	X		
17	125-085								X	X
18	113-140	Bottom Mounting Bracket	X	X	X	X	X	X	X	X
19	137-209	Fill	X	X	X	X	X	X	X	X
20	BFAD-5	Fresh Air Damper Assembly	X	X	X	X	X	X	X	X
22	131X099	Filter Tray	X	X	X	X	X	X	X	X
23	105X877	Left Side Support	X	X	X	X	X	X	X	X
24	147-046	Left Evaporator Support	X	X	X	X	X	X	X	X
25	135-128	Raceway	2	2	2	2	2	2	2	2
26	S111X034	Outlet Air Frame Assembly	X	X	X	X	X	X	X	X
27	105X878	Right Side Support	X	X	X	X	X	X	X	X
28	S543-172-X	Right Side Cover Plate (Outer)	X	X	X	X	X	X	X	X
29	135-129	Heat Shield	X	X	X	X	X	X	X	X
30	113-150-X	Top Rain Flashing	X	X	X	X	X	X	X	X
31	S536-258	Cond. Partition Block Off Plate	X	X	X	X	X	X	X	X
32	S553-521-X	Filter Door Assembly	X	X	X	X	X	X	X	X
33	105-1302	Grommet Retainer	X	X	X	X	X	X	X	X

CABINET COMPONENTS - LEFT HAND MODELS

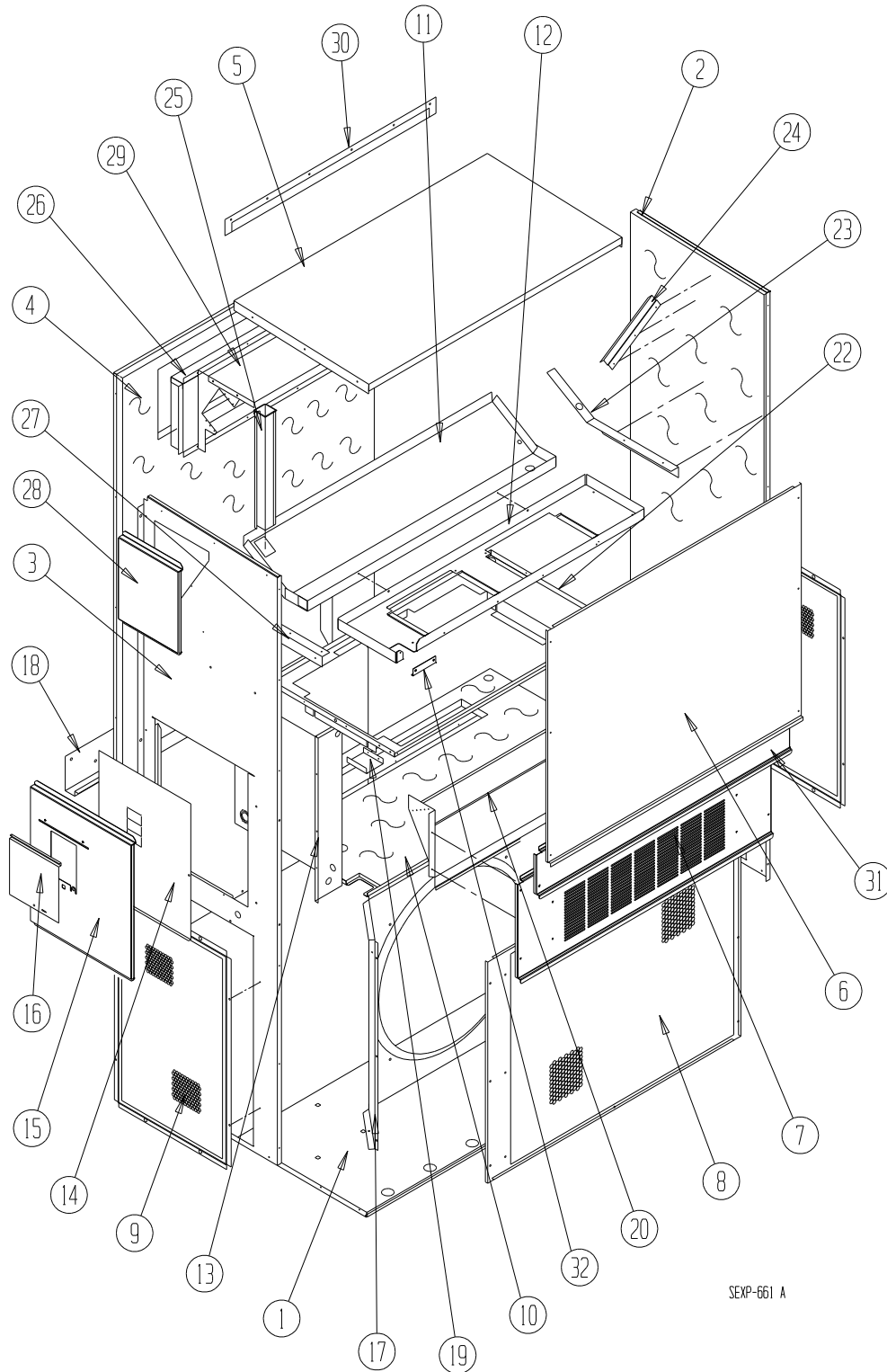

CABINET COMPONENTS – LEFT HAND MODELS

Dwg No.	Part Number	Description	J42L2-A, B	J42L2-C	J48L2-A, B	J48L2-C	J60L2-A, B	J60L2-C	J70L2-A, B	J70L2-C
1	127-428	Lower Base	X	X	X	X	X	X	X	X
2	S501-680-X	Left Side	X	X	X	X	X	X	X	X
3	S501-687-X	Right Side	X	X	X	X	X	X	X	X
4	S508-098	Back	X	X	X	X	X	X	X	X
5	S507-307-X	Top	X	X	X	X	X	X	X	X
6	S515-230-X	Upper Front	X	X	X	X	X	X	X	X
7	S553-522-X	Vent Option Door	X	X	X	X	X	X	X	X
7	S553-529-X	Vent Option Door/ERV	X	X	X	X	X	X	X	X
8	118-049-X	Condenser Grille	X	X	X	X	X	X	X	X
9	118-057-X	Side Grille	2	2	2	2	2	2	2	2
10	S521Y462	Condenser Partition	X	X	X	X	X	X	X	X
11	S123-121	Drain Pan	X	X	X	X	X	X	X	X
12	121Y463	Blower Partition	X	X	X	X	X	X	X	X
13	Control Panel Assy.	See Control Panel Assy. Drawing and Parts List	X	X	X	X	X	X	X	X
14	S132-114	Control Panel Cover (Inner)	X		X		X		X	
14	S132-171	Control Panel Cover (Inner)		X	X		X		X	X
15	S533-227-X	Control Panel Cover (Outer)	X	X	X	X	X	X	X	X
16	S153-218-X	Disconnect Access Door	X	X	X	X	X	X	X	X
17	125-024	Fan Shroud	X	X	X	X	X			
17	125-085	Fan Shroud							X	X
18	113-140	Bottom Mounting Bracket	X	X	X	X	X	X	X	X
19	137-209	Fill	X	X	X	X	X	X	X	X
20	BFAD-5	Fresh Air Damper Assembly	X	X	X	X	X	X	X	X
22	131Y099	Filter Tray	X	X	X	X	X	X	X	X
23	105Y878	Left Side Support	X	X	X	X	X	X	X	X
24	147-046	Left Evaporator Support	X	X	X	X	X	X	X	X
25	135-128	Raceway	2	2	2	2	2	2	2	2
26	S111Y034	Outlet Air Frame Assembly	X	X	X	X	X	X	X	X
27	105Y877	Right Side Support	X	X	X	X	X	X	X	X
28	S543-172-X	Right Side Cover Plate (Outer)	X	X	X	X	X	X	X	X
29	135-129	Heat Shield	X	X	X	X	X	X	X	X
30	113-150-X	Top Rain Flashing	X	X	X	X	X	X	X	X
31	S553-521-X	Filter Door Assembly	X	X	X	X	X	X	X	X
32	105-1302	Grommet Retainer	X	X	X	X	X	X	X	X
NS	S536-258	Cond. Partition Block Off Plate	X	X	X	X	X	X	X	X

NS – Not Shown

FUNCTIONAL COMPONENTS - RIGHT HAND MODELS

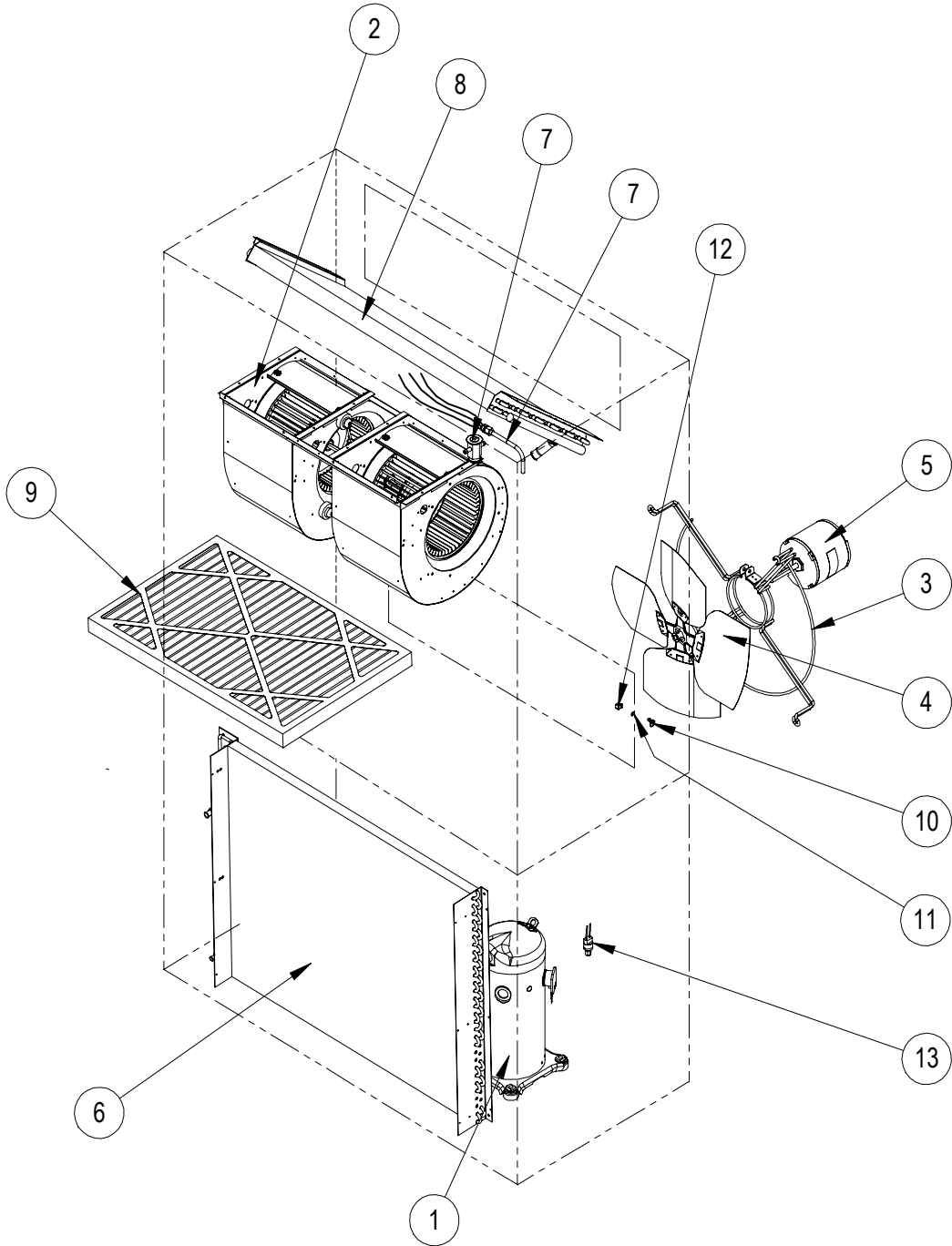

SEXP-177 A

FUNCTIONAL COMPONENTS – RIGHT HAND MODELS

Dwg No.	Part Number	Description	J42A2-A	J42A2-B	J42A2-C	J48A2-A	J48A2-B	J48A2-C	J60A2-A	J60A2-B	J60A2-C	J70A2-A	J70A2-B	J70A2-C
1	8000-318	Compressor	X											
1	8000-319	Compressor		X										
1	8000-320	Compressor			X									
1	8000-400	Compressor				X								
1	8000-401	Compressor					X							
1	8000-402	Compressor						X						
1	8000-324	Compressor							X					
1	8000-325	Compressor								X				
1	8000-326	Compressor									X			
1	8000-403	Compressor										X		
1	8000-404	Compressor											X	
1	8000-405	Compressor												X
2	S900-320	Blower Assembly	X	X		X	X							
2	S900-321	Blower Assembly			X			X						
2	S900-185	Blower Assembly							X	X		X	X	
2	S900-186	Blower Assembly									X			X
3	8200-004	Fan Motor Mount	X	X	X	X	X	X	X	X	X			
3	8200-049	Fan Motor Mount										X	X	X
4	5151-060	Fan Blade	X	X	X	X	X	X	X	X	X			
4	5151-062	Fan Blade										X	X	X
5	8105-039	Condenser Motor	X	X		X	X		X	X				
5	8105-030	Condenser Motor			X			X			X			
5	8106-016	Condenser Motor										X	X	
5	8106-067	Condenser Motor												X
6	5051-179BX	Condenser Coil	X	X	X	X	X	X						
6	5051-180BX	Condenser Coil							X	X	X	X	X	X
7	800-0420	Distributor Assembly	X	X	X									
7	800-0422	Distributor Assembly				X	X	X						
7	800-0423	Distributor Assembly							X	X	X			
7	800-0425	Distributor Assembly										X	X	X
8	917-0206BX	Evaporator Coil	X	X	X									
8	917-0207BX	Evaporator Coil				X	X	X						
8	917-0208BX	Evaporator Coil							X	X	X			
8	917-0209BX	Evaporator Coil										X	X	X
9	7004-016	Air Filter 1" Throw-Away	X	X	X	X	X	X	X	X	X	X	X	X
9	7003-030	Air Filter 1" Washable	X	X	X	X	X	X	X	X	X	X	X	X
9	7004-027	Air Filter 2" Pleated	X	X	X	X	X	X	X	X	X	X	X	X
10	1171-022	1/4 Turn Fastener	X	X	X	X	X	X	X	X	X	X	X	X
11	1171-024	1/4 Turn Retainer	X	X	X	X	X	X	X	X	X	X	X	X
12	1171-023	1/4 Receptacle	X	X	X	X	X	X	X	X	X	X	X	X
13	1804-0462	High Pressure Switch (Flare)	X	X	X	X	X	X	X	X	X	X	X	X
13	1804-0386	Low Pressure Switch (Flare)	X	X	X	X	X	X	X	X	X	X	X	X
NS	5201-022	Filter Drier	X	X	X	X	X	X	X	X	X	X	X	X
NS	CMA-28	Low Ambient Control (Flare) ①	X	X	X	X	X	X	X	X	X	X	X	X
NS	5451-024	Tubing Isolation Grommet	2	2	2	2	2	2	2	2	2	2	2	2
NS	CMC-29	Freeze Thermostat Kit										X	X	X

NS – Not Shown

① – Optional on these models

FUNCTIONAL COMPONENTS - LEFT HAND MODELS

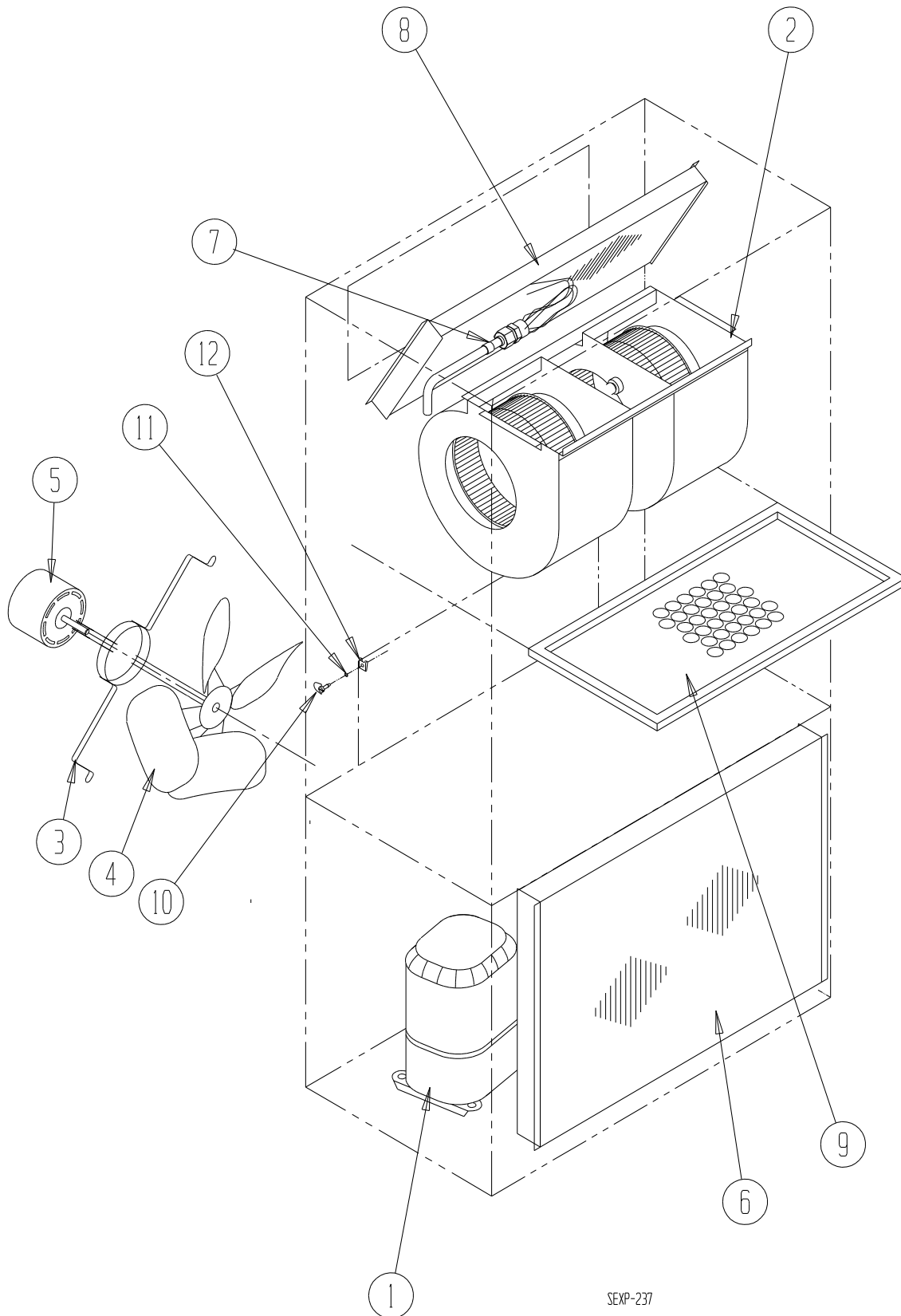

SEXP-237

FUNCTIONAL COMPONENTS – LEFT HAND MODELS

Dwg No.	Part Number	Description	J42L2-A	J42L2-B	J42L2-C	J48L2-A	J48L2-B	J48L2-C	J60L2-A	J60L2-B	J60L2-C	J70L2-A	J70L2-B	J70L2-C
1	8000-318	Compressor	X											
1	8000-319	Compressor		X										
1	8000-320	Compressor			X									
1	8000-400	Compressor				X								
1	8000-401	Compressor					X							
1	8000-402	Compressor						X						
1	8000-324	Compressor							X					
1	8000-325	Compressor								X				
1	8000-326	Compressor									X			
1	8000-403	Compressor										X		
1	8000-404	Compressor											X	
1	8000-405	Compressor												X
2	S900-320	Blower Assembly	X	X		X	X							
2	S900-321	Blower Assembly			X			X						
2	S900-185	Blower Assembly						X	X			X	X	
2	S900-186	Blower Assembly								X				X
3	8200-004	Fan Motor Mount	X	X	X	X	X	X	X	X				
3	8200-049	Fan Motor Mount										X	X	X
4	5151-060	Fan Blade	X	X	X	X	X	X	X	X	X	X	X	X
5	8105-039	Condenser Motor	X	X		X	X		X	X				
5	8105-030	Condenser Motor			X			X			X			
5	8106-016	Condenser Motor										X	X	
5	8107-010	Condenser Motor												X
6	5051-179BX	Condenser Coil	X	X	X	X	X							
6	5051-180BX	Condenser Coil						X	X	X	X	X	X	X
7	800-0420	Distributor Assembly	X	X	X									
7	800-0422	Distributor Assembly				X	X							
7	800-0423	Distributor Assembly						X	X	X				
7	800-0425	Distributor Assembly										X	X	X
8	917-0206BX	Evaporator Coil	X	X	X									
8	917-0207BX	Evaporator Coil				X	X							
8	917-0208BX	Evaporator Coil						X	X	X				
8	917-0209BX	Evaporator Coil										X	X	X
9	7004-016	Air Filter 1" Throw-Away	X	X	X	X	X	X	X	X	X	X	X	X
9	7003-030	Air Filter 1" Washable	X	X	X	X	X	X	X	X	X	X	X	X
9	7004-027	Air Filter 2" Pleated	X	X	X	X	X	X	X	X	X	X	X	X
10	1171-022	1/4 Turn Fastener	X	X	X	X	X	X	X	X	X	X	X	X
11	1171-024	1/4 Turn Retainer	X	X	X	X	X	X	X	X	X	X	X	X
12	1171-023	1/4 Receptacle	X	X	X	X	X	X	X	X	X	X	X	X
NS	1804-0462	High Pressure Switch (Flare)	X	X	X	X	X	X	X	X	X	X	X	X
NS	1804-0386	Low Pressure Switch (Flare)	X	X	X	X	X	X	X	X	X	X	X	X
NS	5201-022	Filter Drier	X	X	X	X	X	X	X	X	X	X	X	X
NS	CMA-28	Low Ambient Control (Flare) ①	X	X	X	X	X	X	X	X	X	X	X	X
NS	5451-024	Tubing Isolation Grommet	2	2	2	2	2	2	2	2	2	2	2	2
NS	CMC-29	Freeze Thermostat Kit										X	X	X

NS – Not Shown

① – Optional on these models

CONTROL PANEL - RIGHT HAND MODELS

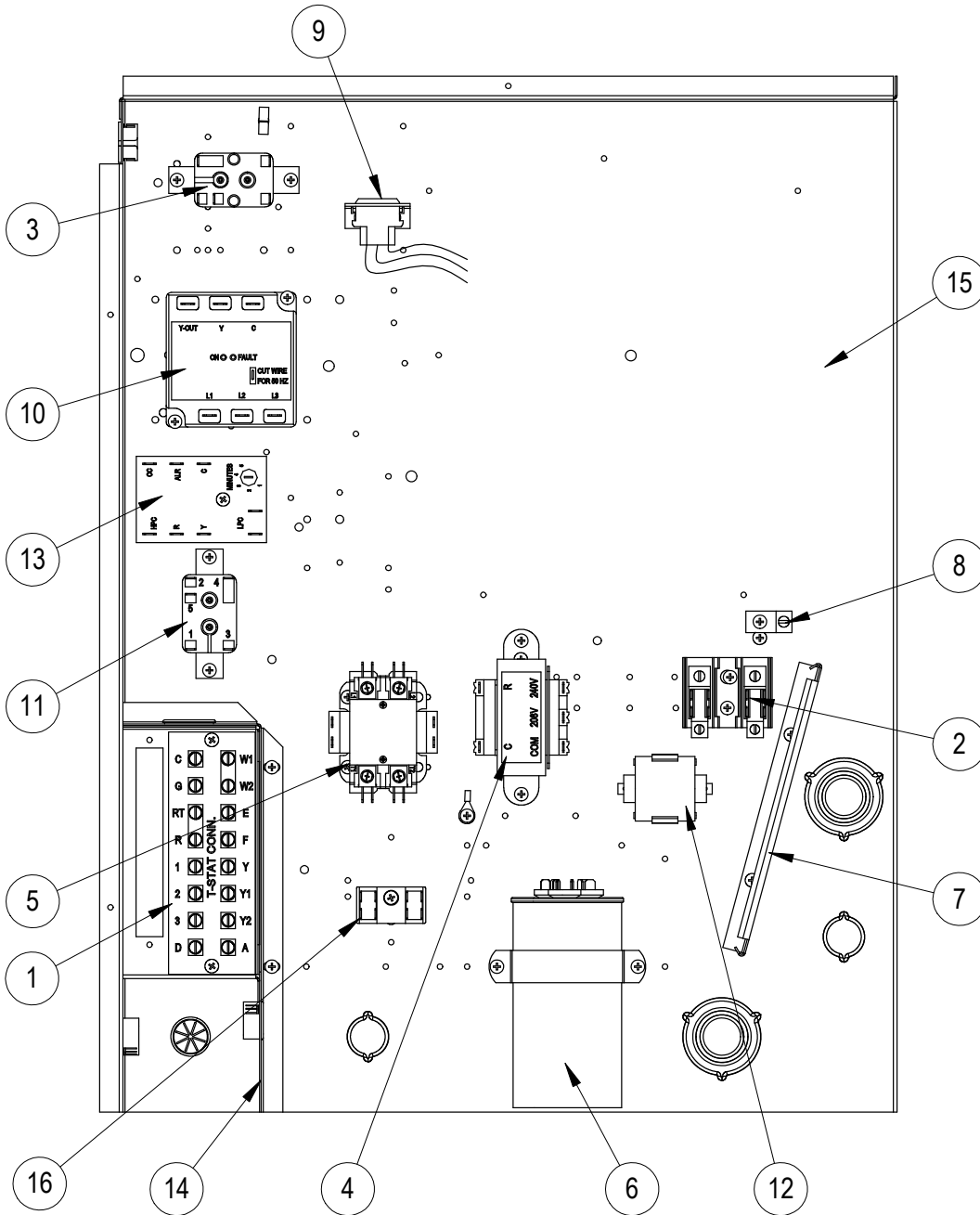

SEXP-659

CONTROL PANEL - RIGHT HAND MODELS

Dwg No.	Part Number	Description	J42A2-A	J42A2-B	J42A2-C	J48A2-A	J48A2-B	J48A2-C	J60A2-A	J60A2-B	J60A2-C	J70A2-A	J70A2-B	J70A2-C
1	8607-034	Low Voltage Terminal Strip	X	X	X	X	X	X	X	X	X	X	X	X
2	8607-013	Terminal Block 2 Pole	X			X			X			X		
2	8607-014	Terminal Block 3 Pole		X	X		X	X		X	X		X	X
2	8607-015	Phenolic Insulator			X			X			X			X
3	8201-009	Blower Control Relay	X	X		X	X		X	X		X	X	
3	8201-032	Blower Control Relay			X			X			X			X
4	8407-034	Transformer	X	X		X	X		X	X		X	X	
4	8407-042	Transformer			X			X			X			X
5	8401-002	Compressor Contactor		X	X		X	X		X	X		X	X
5	8401-025	Compressor Contactor	X			X			X			X		
6	8552-079	Compressor Capacitor	X											
6	8552-005	Outdoor Motor Capacitor		X			X							X
6	8552-026	Outdoor Motor Capacitor			X			X			X			
6	8552-089	Compressor Capacitor				X								
6	8552-058	Compressor Capacitor						X						
6	8552-004	Outdoor Motor Capacitor							X				X	
6	8552-082	Compressor Capacitor									X			
7	135-130	Wire Shield	X	X	X	X	X	X	X	X	X	X	X	X
8	8611-006	Ground Terminal	X	X	X	X	X	X	X	X	X	X	X	X
9	3000-1017	6 Pin Connector	X	X	X	X	X	X	X	X	X	X	X	X
10	8201-126	Phase Monitor		X	X		X	X		X	X		X	X
11	8201-062	Alarm Relay ①	X	X	X	X	X	X	X	X	X	X	X	X
12	8551-004	Start Device (PTCR) ①	X			X			X			X		
13	8201-148	Compressor Control Module	X	X	X	X	X	X	X	X	X	X	X	X
14	117X333	Low Voltage Box	X	X	X	X	X	X	X	X	X	X	X	X
15	117X340	Control Panel	X	X	X	X	X	X	X	X	X	X	X	X
16	8607-017	Terminal Block ①	X	X	X	X	X	X	X	X	X	X	X	X
NS	8615-040	Circuit Breaker 50A 2 Pole ②	X			X								
NS	8615-042	Circuit Breaker 35A 3 Pole ②		X			X							
NS	8615-067	Toggle Disconnect ②			X			X			X			X
NS	8615-041	Circuit Breaker 60A 2 Pole ②						X				X		
NS	8615-043	Circuit Breaker 40A 3 Pole ②							X				X	
NS	4095-163	Wiring Diagram	X			X			X					
NS	4095-255	Wiring Diagram		X			X			X				
NS	4095-357	Wiring Diagram			X			X			X			
NS	4095-165	Wiring Diagram										X		
NS	4095-257	Wiring Diagram											X	
NS	4095-358	Wiring Diagram												X
NS	3000-1222	Compressor Plug Wire Assembly	X	X	X	X	X	X	X	X	X	X	X	X

① Optional on these models.

② Circuit breakers listed are for units without electric heat "OZ" models. Hot gas bypass models not available without electric heat. See heater replacement parts manual for units with electric heat.

NS – Not Shown

CONTROL PANEL – LEFT HAND MODELS

Dwg No.	Part Number	Description	J42L2-A	J42L2-B	J42L2-C	J48L2-A	J48L2-B	J48L2-C	J60L2-A	J60L2-B	J60L2-C	J70L2-A	J70L2-B	J70L2-C
1	8607-034	Low Voltage Terminal Strip	X	X	X	X	X	X	X	X	X	X	X	X
2	8607-013	Terminal Block 2 Pole	X			X			X			X		
2	8607-014	Terminal Block 3 Pole		X	X		X	X		X	X		X	X
2	8607-015	Phenolic Insulator			X			X			X			X
3	8201-009	Blower Control Relay	X	X		X	X		X	X		X	X	
3	8201-032	Blower Control Relay			X			X			X			X
4	8407-034	Transformer	X	X		X	X		X	X		X	X	
4	8407-042	Transformer			X			X			X			X
5	8401-002	Compressor Contactor		X	X		X	X		X	X		X	X
5	8401-025	Compressor Contactor	X			X			X			X		X
6	8552-079	Compressor Capacitor	X											
6	8552-005	Outdoor Motor Capacitor		X										X
6	8552-026	Outdoor Motor Capacitor			X		X				X			
6	8552-089	Compressor Capacitor				X		X						
6	8552-059	Compressor Capacitor					X							
6	8552-004	Outdoor Motor Capacitor							X				X	
6	8552-082	Compressor Capacitor									X			
7	135-130	Wire Shield	X	X	X	X	X	X	X	X	X	X	X	X
8	8611-006	Ground Terminal	X	X	X	X	X	X	X	X	X	X	X	X
9	3000-978	6 Pin Connector	X	X	X	X	X	X	X	X				
9	3000-1017	6 Pin Connector										X	X	X
10	8201-126	Phase Monitor		X	X		X	X		X	X		X	X
11	8201-062	Alarm Relay ①	X	X	X	X	X	X	X	X	X	X	X	X
12	8551-004	Start Device (PTCR) ①	X			X			X			X		
13	8201-148	Compressor Control Module	X	X	X	X	X	X	X	X	X	X	X	X
14	117Y333	Low Voltage Box	X	X	X	X	X	X	X	X	X	X	X	X
15	117Y340	Control Panel	X	X	X	X	X	X	X	X	X	X	X	X
16	8607-017	Terminal Block ①	X	X	X	X	X	X	X	X	X	X	X	X
NS	8615-040	Circuit Breaker 50A 2 Pole ②	X			X								
NS	8615-042	Circuit Breaker 35A 3 Pole ②		X			X							
NS	8615-067	Toggle Disconnect ②			X		X				X			X
NS	8615-041	Circuit Breaker 60A 2 Pole ②						X				X		
NS	8615-043	Circuit Breaker 40A 3 Pole ②							X				X	
NS	4095-163	Wiring Diagram	X			X			X					
NS	4095-255	Wiring Diagram		X			X			X				
NS	4095-357	Wiring Diagram			X			X			X			
NS	4095-165	Wiring Diagram										X		
NS	4095-257	Wiring Diagram											X	
NS	4095-358	Wiring Diagram												X

① Optional on these models.

② Circuit breakers listed are for units without electric heat "OZ" models. Hot gas bypass models not available without electric heat. See heater replacement parts manual for units with electric heat.

NS – Not Shown

BLOWER ASSEMBLY

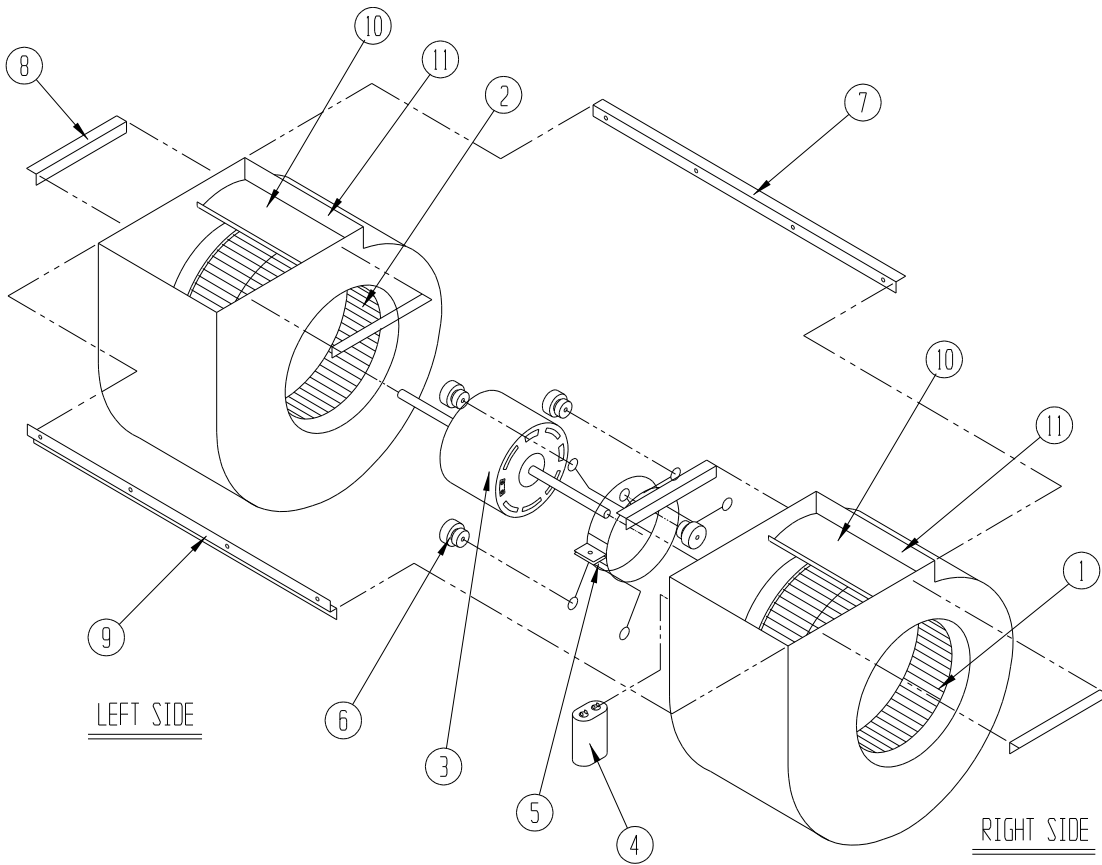

SEXP-178

Dwg No.	Part Number	Description	900-320	900-321	900-185	900-186
1	5152-011	10" Wheel (CW)			X	X
1	5152-057	9" Wheel (CW)	X	X		
2	5152-012	10" Wheel (CW)			X	X
2	5152-058	9" Wheel (CW)	X	X		
3	8105-061	Blower Motor (230/208)	X			
3	8105-062	Blower Motor (460)		X		
3	8106-046	Blower Motor (230/208)			X	
3	8106-025	Blower Motor (460)				X
4	8552-091	Capacitor	X	X		
4	8552-005	Capacitor			X	X
5	8200-040	Motor Mount	X	X	X	X
6	5451-011	Grommets	6	6	6	6
7	105-881	Back Brace	X	X	X	X
8	105-880	Side Angle	4	4	4	4
9	103-389	Front Brace	X	X	X	X
10	151-101	Housing	2	2	2	2
11	144-166	Diffuser	2	2	2	2